

Structural Dynamics Research Corporation (SDRC) Disneyland project proposal

Daniel Belongia

Adam Mayer

Donny Kuettel

Nasser M. Abbasi

December 25, 2015

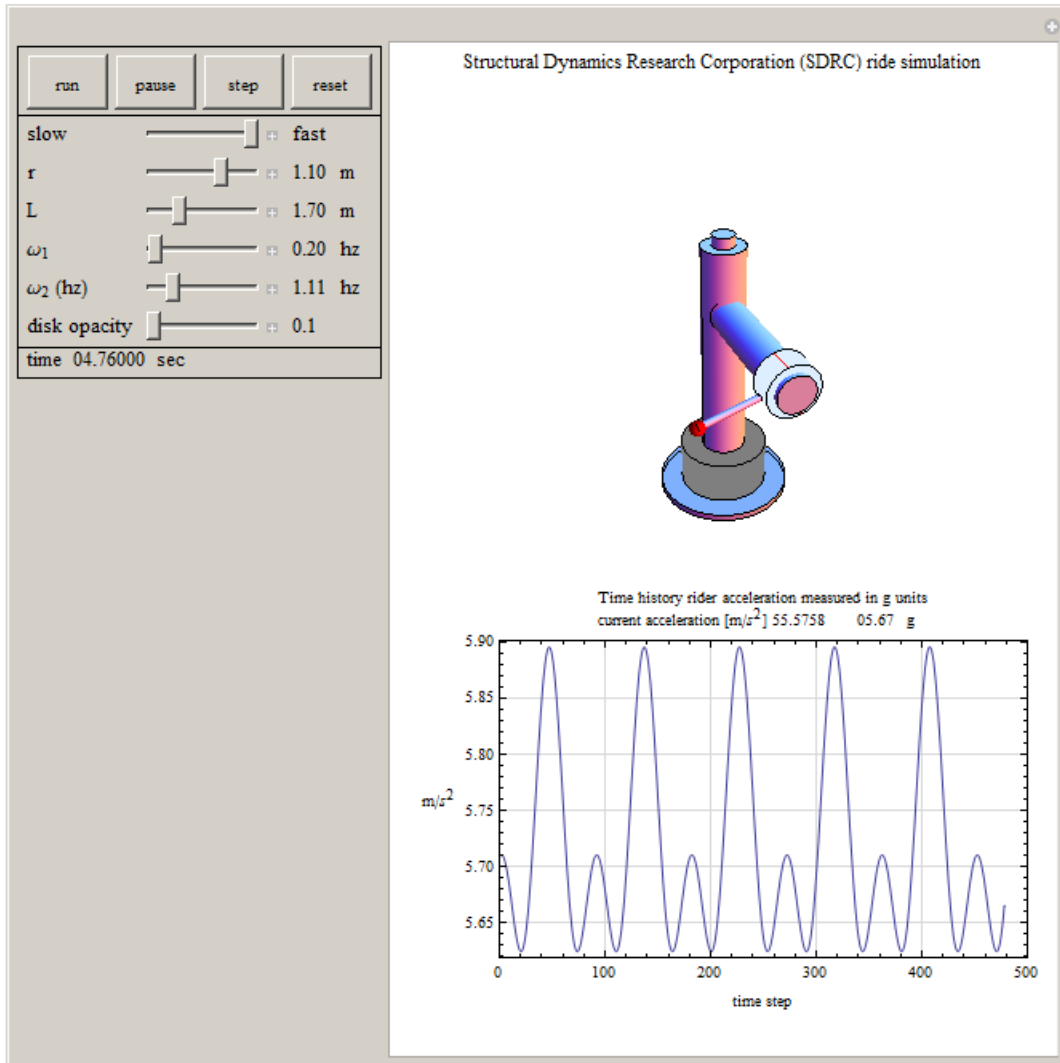

Contents

1	Introduction	3
2	Safety considerations	3
3	Mathematical model of system dynamics	5
4	Conclusion	7
5	Appendix	8
5.1	Ride velocity and acceleration derivation	8
5.2	Design renderings of final ride construction	9
5.3	Parameters used in design	10
5.4	Customer feedback	10
6	References	11

List of Figures

- 1 Gantt Chart showing project progress timeline 4
- 2 Showing main dimensions of ride design 5
- 3 Time history plot for absolute acceleration of ride object for first 5 seconds 6
- 4 Ride description showing rotating coordinate system 8
- 5 View of ride object in rotating coordinates system 8
- 6 Showing ride seating mechanism 10
- 7 Customer feedback from the project proposal 11

List of Tables

- 1 Gantt chart explanation 4
- 2 ride configuration used in design 6
- 3 Material parameters 10

1 Introduction

A four-member team at Structural Dynamics Research Corporation (SDRC) has completed the preliminary design for a new spinning ride for Disneyland.

The team includes one graduate student and three undergraduate students in Engineering Mechanics and Astronautics, whose experience in advanced and structural dynamics will contribute to the creation of a world-class ride. Additional skills that the team will bring to the table include extensive programming experience in Matlab and Mathematica, as well as finite element modeling in Ansys.

The ride features two non-collinear components of angular velocity, and the head of each of the two passengers will experience a maximum of $6g$ of acceleration. The ride is specifically designed to be light, safe, affordable, and fun.

The team at SDRC would like to perform a more detailed design and analysis of the ride, so the following pages provide contractors at Disneyland with an overview of what they can expect from the ride. Safety considerations and acceleration calculations are highlighted, and some information on team members and a project management plan are also included.

The next step after this initial proposal will be a detailed structural and failure analysis on the system, which Disneyland can expect in December.

2 Safety considerations

The Flight Simulator will be equipped with multiple safety measures to ensure that the pilots have a fun and exciting ride. In order to ride the Flight Simulator, each passenger must be at least 5 feet tall. This insures that the riders can be securely fastened into the seat. Assuming an average rider weight of 175 pounds, one single rider cannot weigh more than 350 pounds.

Any more weight will induce a moment on the main arm that might be considered unsafe. A factor of safety will be factored into the building of the arm in case two riders combined weight to be more than 350 pounds.

This is because with the extended arm and accelerations the main arm will be subject to, it is believed to be the first membrane to fail. In order to start the ride, it must be certain that the arm will not break during the ride. While riding, each rider will be harnessed into his or her seat via a 3-point harness.

The harness will let the passengers fly upside-down while still secured in the cockpit. Since the Flight Simulator will be subject to $6g$ acceleration, complementary sick bags will be provided upon starting.

In case of a medical emergency of a passenger or if it has been determined that it is unsafe to ride mid-flight, an emergency stop will be activated which will bring the ride to an end. When activated, the ride will right itself upwards while bringing itself to a stop about the center of the ride. This is so when the ride stops, the passengers are not hanging upside down which would be unsafe.

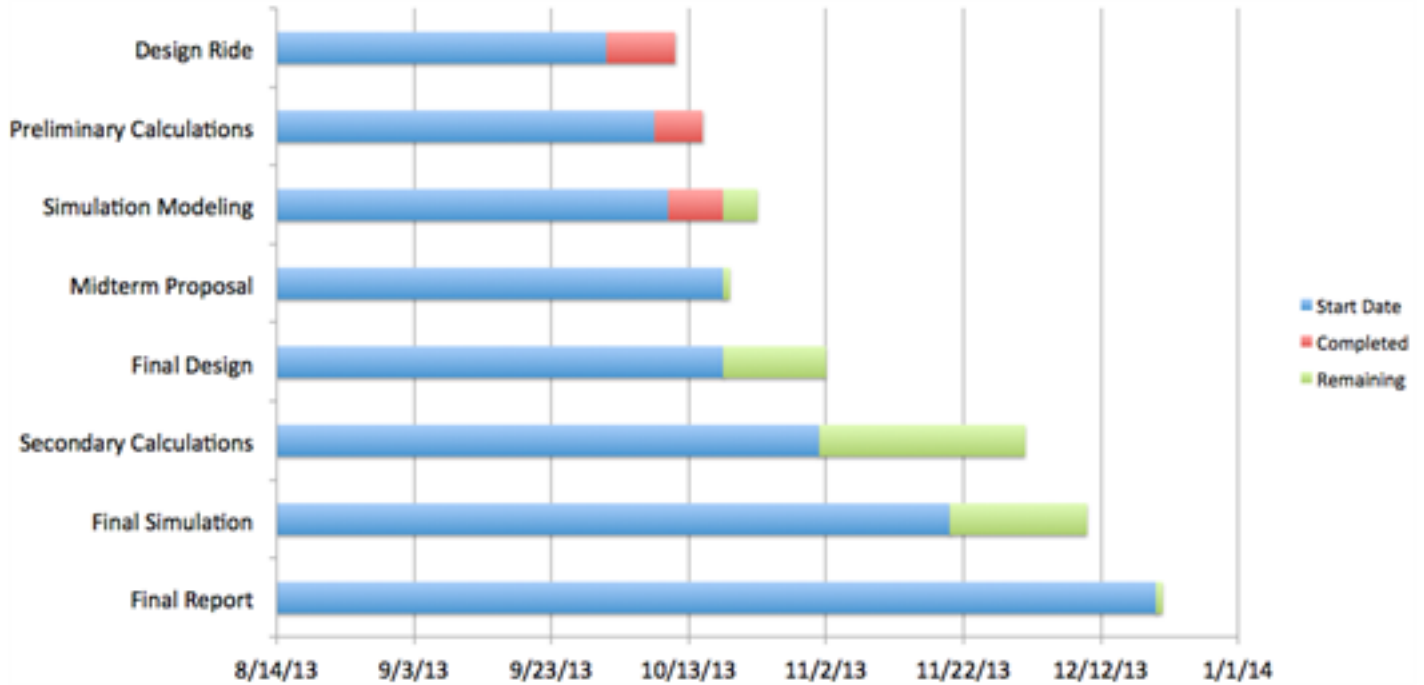

Figure 1: Gantt Chart showing project progress timeline

The following table describes the activities shown on the Gantt chart above.

Activity	Description
Design ride	Coming up with a ride that would be functional and meets all expectations.
Preliminary calculations	With ride chosen, calculations showing the velocity and acceleration of the rider's head symbolically.
Simulation modeling	Modeling the ride with a simulator with sliders to estimate the angular velocities.
Midterm proposal	When the midterm proposal of the ride is requested by the company.
Final design	Finalizing how the ride will work.
Secondary calculations	After finalizing how ride will work, will compute secondary calculations to know which velocities will work to add up to give the desired acceleration for each passenger.
Final modeling	Once the angular velocities are known, make a model to show how the ride will work when everything comes together.
Final report	When the customer wants the final report to know if they would like to purchase the ride that we have created.

Table 1: Gantt chart explanation

3 Mathematical model of system dynamics

The velocity and acceleration of the ride object was derived such that it is valid for all time. The derived equations are used in a simulation program written for this proposal in order to generate the acceleration time history and be able to modify the ride parameters more easily to find the optimal combination to meet the given specifications of maximum 6g customer requirements.

The simulation was done assuming the ride is at steady state, hence angular accelerations are set to zero. The following diagram illustrates the four design parameters used in the simulation and the expressions found for the velocity and acceleration. The appendix contains the detailed derivation.

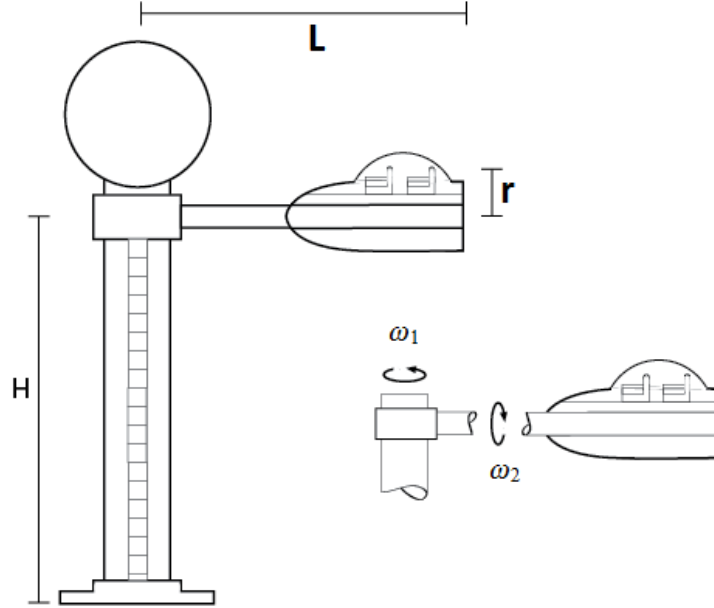

Figure 2: Showing main dimensions of ride design

The absolute velocity of the ride was found to be

$$\vec{V} = (r\omega_2 \cos \omega_2 t - \omega_1 L) \vec{i} + \omega_1 r \sin \omega_2 t \vec{j} - r\omega_2 \sin \omega_2 t \vec{k}$$

And the absolute acceleration is

$$\begin{aligned} \vec{a} = & \vec{i} \left(r\dot{\omega}_2 \cos \omega_2 t - r\omega_2^2 \sin \omega_2 t + \dot{\omega}_1 L - \omega_1^2 r \sin \omega_2 t \right) \\ & + \vec{j} \left(2r\omega_1 \omega_2 \cos \omega_2 t + \dot{\omega}_1 r \sin \omega_2 t - \omega_1^2 L \right) \\ & + \vec{k} \left(-r\dot{\omega}_2 \sin \omega_2 t - r\omega_2^2 \cos \omega_2 t \right) \end{aligned}$$

The following diagram gives the acceleration time history for the ride. This plot was generated for the first 5 seconds of the ride in steady state. It shows that the maximum acceleration did not exceed 6g during the simulation which included more than 5 complete cycles. The following table shows the ride configuration used to achieve the above time history. These values are the anticipated design parameters to use to complete the structural analysis, but these could change based on results of the structural design.

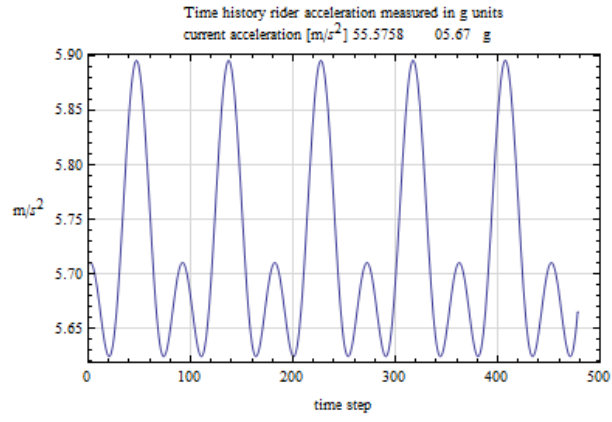

Figure 3: Time history plot for absolute acceleration of ride object for first 5 seconds

Table 2: ride configuration used in design

Length of beam (L)	1.7 meter
Height of person head above beam (r)	1.1 meter
Angular velocity of ride cabinet (ω_2)	0.2 Hz
Angular velocity of main vertical support column (ω_1)	1.11 Hz

4 Conclusion

The preliminary design for this two-passenger ride features two components of non-collinear angular velocity, and the head of each passenger experiences a maximum of $6g$ of acceleration.

The design and calculations indicate that this will be a fun and light ride. Safety considerations were highlighted, and a management plan and team qualifications underscore the team's commitment to excellence and sound engineering. A more detailed stress analysis of the system will be delivered in December.

5 Appendix

5.1 Ride velocity and acceleration derivation

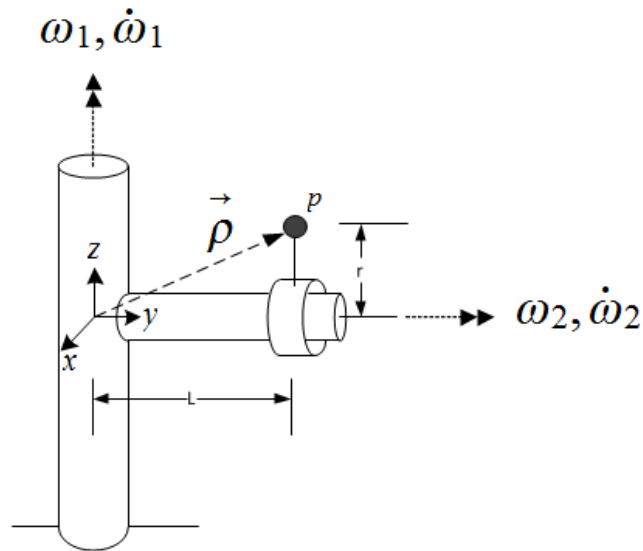

Figure 4: Ride description showing rotating coordinate system

The rotating coordinates system has its origin as shown in the above diagram. The coordinates system is attached to the column and therefore rotates with the column. The following calculation determines the absolute velocity of the ride object head, shown above as the circle p at distance r from the center of beam. All calculations are expressed using unit vectors of the rotating coordinates system and will be valid for all time. In the rotating coordinates system, the ride object appears as shown in the following diagram Using the above diagrams, the absolute velocity vector is found as follows

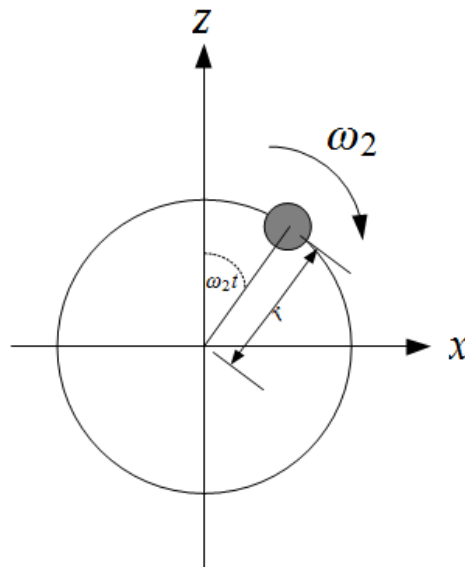

Figure 5: View of ride object in rotating coordinates system

$$\begin{aligned}
\vec{\rho} &= L\vec{j} + r \sin \omega_2 t \vec{i} + r \cos \omega_2 t \vec{k} \\
\dot{\vec{\rho}}_r &= r\omega_2 \cos \omega_2 t \vec{i} - r\omega_2 \sin \omega_2 t \vec{k} \\
\dot{\vec{R}} &= 0 \\
\vec{\omega} &= \omega_1 \vec{k} \\
\vec{\omega} \times \vec{\rho} &= -\omega_1 L \vec{i} + \omega_1 r \sin \omega_2 t \vec{j}
\end{aligned}$$

Hence

$$\begin{aligned}
\vec{V} &= \dot{\vec{R}} + \dot{\vec{\rho}}_r + \vec{\omega} \times \vec{\rho} \\
&= r\omega_2 \cos \omega_2 t \vec{i} - r\omega_2 \sin \omega_2 t \vec{k} - \omega_1 L \vec{i} + \omega_1 r \sin \omega_2 t \vec{j} \\
&= (r\omega_2 \cos \omega_2 t - \omega_1 L) \vec{i} + \omega_1 r \sin \omega_2 t \vec{j} - r\omega_2 \sin \omega_2 t \vec{k}
\end{aligned} \tag{1}$$

Now the absolute acceleration of the passengers is found

$$\begin{aligned}
\ddot{\vec{\rho}}_r &= \left(r\dot{\omega}_2 \cos \omega_2 t - r\omega_2^2 \sin \omega_2 t \right) \vec{i} + \left(-r\dot{\omega}_2 \sin \omega_2 t - r\omega_2^2 \cos \omega_2 t \right) \vec{k} \\
\ddot{\vec{R}} &= 0 \\
\dot{\vec{\omega}} &= \dot{\omega}_1 \vec{k} \\
\vec{\omega} \times \left(\vec{\omega} \times \vec{\rho} \right) &= \omega_1 \vec{k} \times \left(-\omega_1 L \vec{i} + \omega_1 r \sin \omega_2 t \vec{j} \right) = -\omega_1^2 L \vec{j} - \omega_1^2 r \sin \omega_2 t \vec{i} \\
\vec{\omega} \times \dot{\vec{\rho}}_r &= \omega_1 \vec{k} \times \left(r\omega_2 \cos \omega_2 t \vec{i} - r\omega_2 \sin \omega_2 t \vec{k} \right) = r\omega_1 \omega_2 \cos \omega_2 t \vec{j} \\
\dot{\vec{\omega}} \times \vec{\rho} &= \dot{\omega}_1 \vec{k} \times \left(L\vec{j} + r \sin \omega_2 t \vec{i} + r \cos \omega_2 t \vec{k} \right) = \dot{\omega}_1 L \vec{i} + \dot{\omega}_1 r \sin \omega_2 t \vec{j}
\end{aligned}$$

Hence, the absolute acceleration of the ride object head is

$$\begin{aligned}
\vec{a} &= \ddot{\vec{R}} + \ddot{\vec{\rho}}_r + 2 \left(\vec{\omega} \times \dot{\vec{\rho}}_r \right) + \left(\dot{\vec{\omega}} \times \vec{\rho} \right) + \vec{\omega} \times \left(\vec{\omega} \times \vec{\rho} \right) \\
&= \left(r\dot{\omega}_2 \cos \omega_2 t - r\omega_2^2 \sin \omega_2 t \right) \vec{i} + \left(-r\dot{\omega}_2 \sin \omega_2 t - r\omega_2^2 \cos \omega_2 t \right) \vec{k} \\
&\quad + 2r\omega_1 \omega_2 \cos \omega_2 t \vec{j} + \dot{\omega}_1 L \vec{i} + \dot{\omega}_1 r \sin \omega_2 t \vec{j} - \omega_1^2 L \vec{j} - \omega_1^2 r \sin \omega_2 t \vec{i}
\end{aligned}$$

Simplifying gives

$$\begin{aligned}
\vec{a} &= \vec{i} \left(r\dot{\omega}_2 \cos \omega_2 t - r\omega_2^2 \sin \omega_2 t + \dot{\omega}_1 L - \omega_1^2 r \sin \omega_2 t \right) \\
&\quad + \vec{j} \left(2r\omega_1 \omega_2 \cos \omega_2 t + \dot{\omega}_1 r \sin \omega_2 t - \omega_1^2 L \right) \\
&\quad + \vec{k} \left(-r\dot{\omega}_2 \sin \omega_2 t - r\omega_2^2 \cos \omega_2 t \right)
\end{aligned} \tag{2}$$

5.2 Design renderings of final ride construction

The following two diagrams illustrate the completed ride construction in place, showing the main dimensions and major components

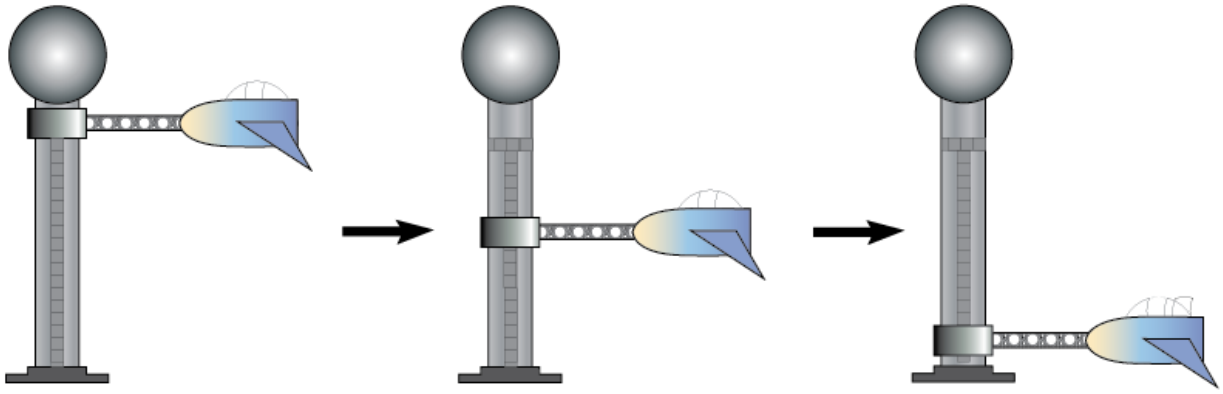

Figure 6: Showing ride seating mechanism

5.3 Parameters used in design

Material parameters used are given in the following table

Table 3: Material parameters

Material used for beam	Aluminium
E (Young's modulus)	70 GPa
Shear modulus	26 GPa
Bulk modulus	76 GPa
Poisson ratio	0.35
Density	2700 kg/m^3

5.4 Customer feedback

Project Team 3 Proposal Comments

1. Next time, please use only one side of the page.
2. The Introduction is good, but you don't make any reference to the name of the ride or a figure of it. You have a figure on the cover page, but never say that it shows your ride. You need lots of figures within the text of the proposal to show the ride, and how it works to the customer.
3. You have a nice Gantt chart, but you never reference or discuss it within the proposal. You need a section that contains the discussion of your project timeline.
4. You should add a bit more detail to your analysis procedure within the text of the report, and not leave all of it for the appendix. Equations should be numbered in the right hand margin.
5. What about startup and shutdown? Are loads during these events important?
6. Figures in Section 5.2 would be good to include in the text of the report to illustrate how the ride works to the customer.
5. The Conclusion is very weak. You should summarize everything you just told the customer. This is your last chance to sell the customer on your ride. Give more details on just what you are going to deliver to the customer if they select your ride for funding.

Otherwise, pretty good!

Figure 7: Customer feedback from the project proposal

6 References

1. Aluminium page at Wikipedia <http://en.wikipedia.org/wiki/Aluminium>
2. Moments of inertia page at Wikipedia http://en.wikipedia.org/wiki/List_of_moments_of_inertia
3. Density of materials page <http://physics.info/density/>
4. Beam design formulas with shear and moment diagrams book, AWC council, 2007, Washington, DC.