

HW 7
Electronic Communication Systems
Fall 2008
California State University, Fullerson

Nasser M. Abbasi

Fall 2008 Compiled on May 29, 2019 at 10:17pm

Contents

| | | |
|---|--------------|----|
| 1 | Questions | 2 |
| 2 | Key solution | 8 |
| 3 | my graded HW | 11 |

1 Questions

ap. 5 Problems

*Book Coash ?
HW questions. Used for HW's 7, 8, 9, 10*

369

$$(f_c)_{\text{SSB}} - f_1 = 7090 \text{ kHz} - 2.225 \text{ kHz} = 7087.775 \text{ kHz}$$

a space frequency (binary 0) of

$$(f_c)_{\text{SSB}} - f_2 = 7090 - 2.025 = 7087.975 \text{ kHz}$$

and a carrier frequency of

$$(f_c)_{\text{FSK}} = (f_c)_{\text{SSB}} - (f_c)_{\text{Bell 103}} = 7090 - 2.125 = 7087.875 \text{ kHz}$$

Consequently, the SSB transceiver would produce a FSK digital signal with a carrier frequency of 7087.875 kHz.

For the case of alternating data, the spectrum of this FSK signal is given by (5-85) and (5-86), where $f_c = 7087.875 \text{ kHz}$. The resulting spectral plot would be like that of Fig. 5-26a, where the spectrum is translated from $f_c = 1170 \text{ Hz}$ to $f_c = 7087.875 \text{ kHz}$. It is also realized that this spectrum appears on the lower sideband of the SSB carrier frequency $(f_c)_{\text{SSB}} = 7090 \text{ kHz}$. If a DSB-SC transmitter had been used (instead of a LSSB transmitter), the spectrum would be replicated on the upper sideband as well as on the lower sideband, and two redundant FSK signals would be emitted.

For the case of random data, the PSD for the complex envelope is given by (5-90) and shown in Fig. 5-25 for the modulation index of $h = 0.7$. Using (5-2b), the PSD for the FSK signal is the translation of the PSD for the complex envelope to the carrier frequency of 7087.875 kHz.

5-1 An AM broadcast transmitter is tested by feeding the RF output into a 50- Ω (dummy) load. Tone modulation is applied. The carrier frequency is 850 kHz and the FCC licensed power output is 5000 W. The sinusoidal tone of 1000 Hz is set for 90% modulation.

- Evaluate the FCC power in dBk (dB above 1 kW) units.
- Write an equation for the voltage that appears across the 50- Ω load, giving numerical values for all constants.
- Sketch the spectrum of this voltage as it would appear on a calibrated spectrum analyzer.
- What is the average power that is being dissipated in the dummy load?
- What is the peak envelope power?

5-2 An AM transmitter is modulated with an audio testing signal given by $m(t) = 0.2 \sin \omega_1 t + 0.5 \cos \omega_2 t$, where $f_1 = 500 \text{ Hz}$, $f_2 = 500 \sqrt{2} \text{ Hz}$, and $A_c = 100$. Assume that the AM signal is fed into a 50- Ω load.

- Sketch the AM waveform.
- What is the modulation percentage?
- Evaluate and sketch the spectrum of the AM waveform.

5-3 For the AM signal given in Prob. 5-2:

- Evaluate the average power of the AM signal.
- Evaluate the PEP of the AM signal.

is this Normalized power or carrier power

5-4 Assume that an AM transmitter is modulated with a video testing signal given by $m(t) = -0.2 + 0.6 \sin \omega_1 t$ where $f_1 = 3.57 \text{ MHz}$. Let $A_c = 100$.

- Sketch the AM waveform.
- What is the percentage of positive and negative modulation?
 - Evaluate and sketch the spectrum of the AM waveform about f_c .

370

$P_{av} = \cos^2 \theta$

5-5 A 50,000-W AM broadcast transmitter is being evaluated by means of a two-tone test transmitter is connected to a 50-Ω load and $m(t) = A_1 \cos \omega_1 t + A_1 \cos 2\omega_1 t$ where $f_1 = 500$ Hz. Assume that a perfect AM signal is generated.
 (a) Evaluate the complex envelope for the AM signal in terms of A_1 and ω_1 .
 (b) Determine the value of A_1 for 90% modulation.
 (c) Find the values for the peak current and average current into the 50-Ω load for the 90% modulation case.

5-6 An AM transmitter uses a two-quadrant multiplier so that the transmitted signal is described by (5-7). Assume that the transmitter is modulated by $m(t) = A_m \cos \omega_m t$, where A_m is adjusted so that 120% positive modulation is obtained. Evaluate the spectrum of this AM signal in terms of A_c , f_c , and f_m . Sketch your result.

5-7 A DSB-SC signal is modulated by $m(t) = \cos \omega_1 t + 2 \cos 2\omega_1 t$ where $\omega_1 = 500$ Hz, and $A_c = 1$.
 (a) Write an expression for the DSB-SC signal and sketch a picture of this waveform.
 (b) Evaluate and sketch the spectrum for this DSB-SC signal.
 (c) Find the value of the average (normalized) power.
 (d) Find the value of the PEP (normalized).

5-8 Assume that transmitting circuitry restricts the modulated output signal to a certain peak value A_p , because of power-supply voltages that are used and the peak voltage and current of the components. If a DSB-SC signal with a peak value of A_p is generated by this circuitry, show that the sideband power of this DSB-SC signal is four times the sideband power of a conventional AM signal having the same peak value, A_p , that could also be generated by this circuitry.

5-9 A DSB-SC signal can be generated from two AM signals as shown in Fig. P5-9. Use mathematics to describe signals at each point on the figure prove that the output is a DSB-

mathematics

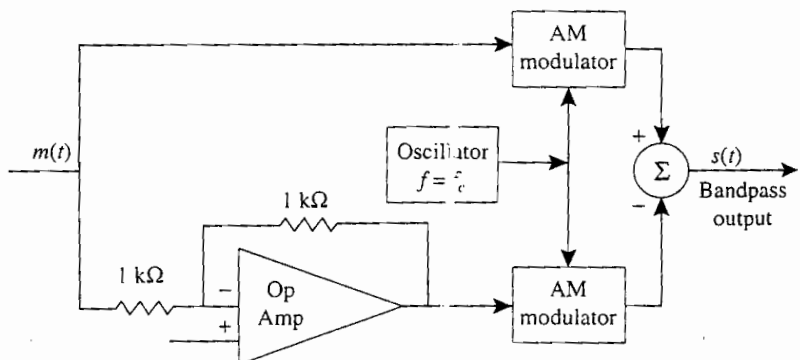

Figure P5-9

5-10 Show that the complex envelope $g(t) = m(t) - \hat{m}(t)$ produces a lower SSB signal than $m(t)$ is a real signal.

5-11 Show that the impulse response of a -90° phase shift network (i.e., a Hilbert transform) is $1/\pi$. Hint:

$$H(f) = \lim_{a \rightarrow 0} \begin{cases} -je^{-af}, & f > 0 \\ je^{af}, & f < 0 \end{cases}$$

$A_p = A_c$

peak value

- 5-12 SSB signals can be generated by the phasing method, Fig. 5-5a; the filter method, Fig. 5-5b; or by the use of Weaver's method as shown in Fig. P5-12. For Weaver's method (Fig. P5-12) where B is the bandwidth of $m(t)$:

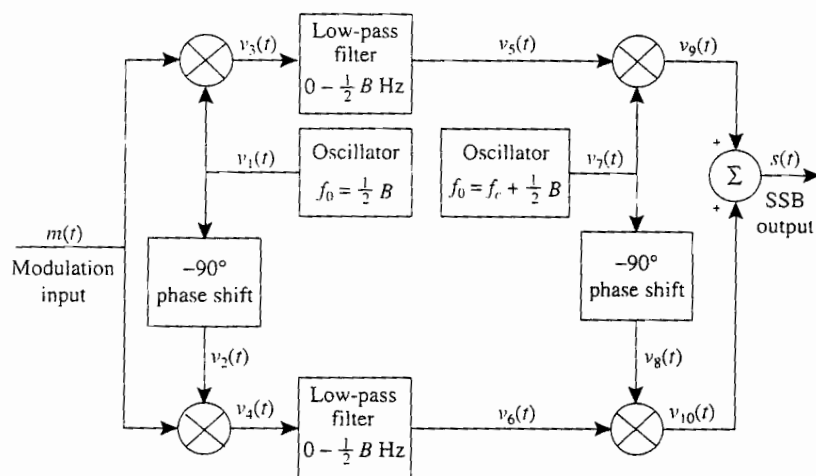

Figure P5-12 Weaver's method for generating SSB.

- (a) Find a mathematical expression that describes the waveform out of each block on the block diagram.
 (b) Show that $s(t)$ is an SSB signal.

- 5-13 An SSB-AM transmitter is modulated with a sinusoid $m(t) = 5 \cos \omega_1 t$, where $\omega_1 = 2\pi f_1$, $f_1 = 500$ Hz, and $A_c = 1$.
- (a) Evaluate $\hat{m}(t)$.
 (b) Find the expression for a lower SSB signal.
 (c) Find the rms value of the SSB signal. ←
 (d) Find the peak value of the SSB signal. ✓
 (e) Find the normalized average power of the SSB signal. ←
 (f) Find the normalized PEP of the SSB signal.

- 5-14 An SSB-AM transmitter is modulated by a rectangular pulse such that $m(t) = \Pi(t/T)$ and $A_c = 1$.

- (a) Prove that

$$\hat{m}(t) = \frac{1}{\pi} \ln \left| \frac{2t + T}{2t - T} \right|$$

as given in Table A-7.

- (b) Find an expression for the SSB-AM signal, $s(t)$, and sketch $s(t)$.
 (c) Find the peak value of $s(t)$.

- 5-15 For Prob. 5-14:

- (a) Find the expression for the spectrum of a USSB-AM signal.
 (b) Sketch the magnitude spectrum, $|S(f)|$.

5-16 A USSB transmitter is modulated with the pulse



$$m(t) = \frac{\sin \pi at}{\pi at}$$

(a) Prove that

$$\hat{m}(t) = \frac{\sin^2[(\pi a/2)t]}{(\pi a/2)t}$$

(b) Plot the corresponding USSB signal waveform for the case of $A_c = 1$, $a = 2$, and $f_c = 20$ Hz.

5-17 A USSB-AM signal is modulated by a rectangular pulse train:

$$m(t) = \sum_{n=-\infty}^{\infty} \Pi[(t - nT_0)/T]$$

where $T_0 = 2T$.

(a) Find the expression for the spectrum of the SSB-AM signal.

(b) Sketch the magnitude spectrum, $|S(f)|$.

5-18 A phasing-type SSB-AM detector is shown in Fig. P5-18. This circuit is attached to the IF output of a conventional superheterodyne receiver to provide SSB reception.

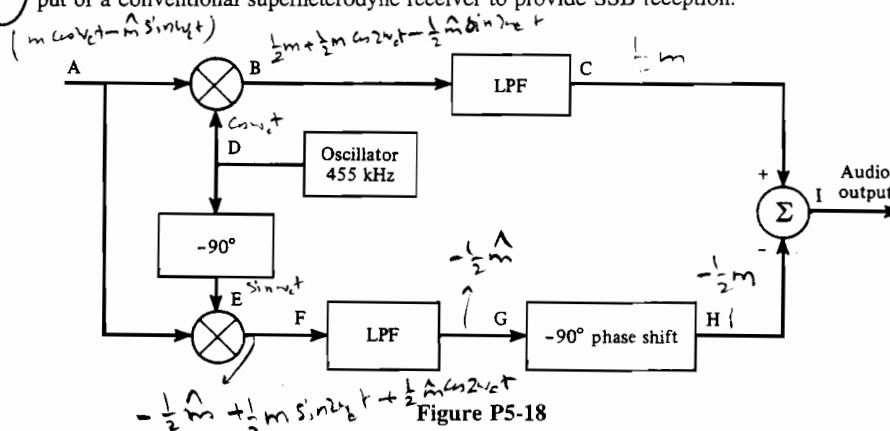

- (a) Determine whether this detector is sensitive to LSSB or USSB signals. How would the detector be changed to receive SSB signals with alternate (opposite type of) sidebands?
- (b) Assume that the signal at point A is a USSB signal with $f_c = 455$ kHz. Find the mathematical expressions for the signals at points B through I.
- (c) Repeat part (b) for the case of an LSSB-AM signal at point A.
- (d) Discuss the IF and LP filter requirements if the SSB signal at point A has a 3-kHz bandwidth.

5-19 Can a Costas loop, as shown in Fig. 5-3, be used to demodulate an SSB-AM signal? Demonstrate that your answer is correct by using mathematics.

5-20 A modulated signal is described by the equation

$$s(t) = 10 \cos[(2\pi \times 10^8)t + 10 \cos(2\pi \times 10^3 t)]$$

Find each of the following.

- (a) Percentage of AM.
 (b) Normalized power of the modulated signal.
 (c) Maximum phase deviation.
 (d) Maximum frequency deviation.



5-21 A sinusoidal signal, $m(t) = \cos 2\pi f_m t$, is the input to an angle-modulated transmitter where the carrier frequency is $f_c = 1$ Hz and $f_m = f_c/4$.

- (a) Plot $m(t)$ and the corresponding PM signal where $D_p = \pi$.
 (b) Plot $m(t)$ and the corresponding FM signal where $D_f = \pi$.

✓ 5-22 A sinusoidal modulating waveform of amplitude 4 V and a frequency of 1 kHz is applied to an FM exciter that has a modulator gain of 50 Hz/V.

- (a) What is the peak frequency deviation?
 (b) What is the modulation index?

5-23 An FM signal has sinusoidal modulation with a frequency of $f_m = 15$ kHz and modulation index of $\beta = 2.0$.

- (a) Find the transmission bandwidth using Carson's rule.
 (b) What percentage of the total FM signal power lies within the Carson rule bandwidth?

✓ 5-24 An FM transmitter has a block diagram as shown in Fig. P5-24. The audio frequency response is flat over the 20-Hz to 15-kHz audio band. The FM output signal is to have a carrier frequency of 103.7 MHz and a peak deviation of 75 kHz.

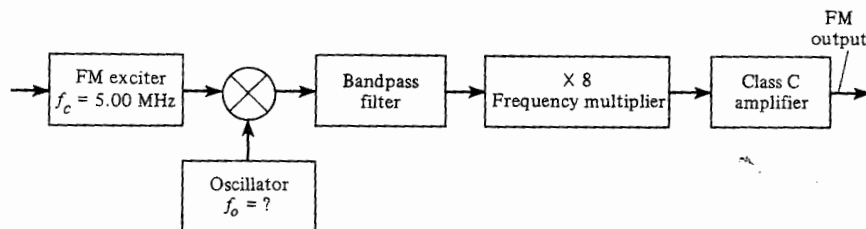

Figure P5-24

- (a) Find the bandwidth and center frequency required for the bandpass filter.
 (b) Calculate the frequency f_0 of the oscillator.
 (c) What is the required peak deviation capability of the FM exciter?

5-25 Analyze the performance of the FM circuit of Fig. 5-8b. Assume that the voltage appearing across the reversed-biased diodes, which provide the voltage variable capacitance, is $v(t) = 5 + 0.05m(t)$, where the modulating signal is a test tone, $m(t) = \cos \omega_1 t$, $\omega_1 = 2\pi f_1$, and $f_1 = 1$ kHz. The capacitance of each of the biased diodes is $C_d = 100/\sqrt{1 + 2v(t)}$ pF. Assume that $C_0 = 180$ pF and that L is chosen to resonate at 5 MHz.

- (a) Find the value of L .
 (b) Show that the resulting oscillator signal is an FM signal. For convenience, assume that the peak level of the oscillator signal is 10 V. Find the parameter D_f .

✓ 5-26 A modulated RF waveform is given by $500 \cos[\omega_c t + 20 \cos \omega_1 t]$, where $\omega_1 = 2\pi f_1$, $f_1 = 1$ kHz, and $f_c = 100$ MHz.

- (a) If the phase deviation constant is 100 rad/V, find the mathematical expression for the corresponding phase modulation voltage $m(t)$. What is its peak value and its frequency?
 (b) If the frequency deviation constant is 1×10^6 rad/V-s, find the mathematical expression for the corresponding FM voltage, $m(t)$. What is its peak value and its frequency?
 (c) If the RF waveform appears across a 50- Ω load, determine the average power and the PEP.

- ✓ 5-27 Given the FM signal $s(t) = 10 \cos [\omega_c t + 100 \int_{-\infty}^t m(\sigma) d\sigma]$, where $m(t)$ is a polar square wave signal with a duty cycle of 50%, a period of 1 s, and a peak value of 5 V.
- Sketch the instantaneous frequency waveform and the waveform of the corresponding FM signal (see Fig. 5-9).
 - Plot the phase deviation $\theta(t)$ as a function of time.
 - Evaluate the peak frequency deviation.
- 5-28 A carrier $s(t) = 100 \cos(2\pi \times 10^9 t)$ of an FM transmitter is modulated with a tone signal. For this transmitter a 1-V (rms) tone produces a deviation of 30 kHz. Determine the amplitude and frequency of all FM signal components (spectral lines) that are greater than 1% of the unmodulated carrier amplitude for the following modulating signals
- $m(t) = 2.5 \cos(3\pi \times 10^4 t)$.
 - $m(t) = 1 \cos(6\pi \times 10^4 t)$.
- 5-29 Referring to (5-58), show that

$$J_{-n}(\beta) = (-1)^n J_n(\beta)$$

- 5-30 Consider an FM exciter with the output $s(t) = 100 \cos[2\pi 1000t + \theta(t)]$. The modulation $m(t) = 5 \cos(2\pi 8t)$ and the modulation gain of the exciter is 8 Hz/V. The FM output signal passed through an ideal (brickwall) bandpass filter which has a center frequency of 1000 Hz bandwidth of 56 Hz, and a gain of unity. Determine the normalized average power:
- At the bandpass filter input.
 - At the bandpass filter output.
- 5-31 A 1-kHz sinusoidal signal phase modulates a carrier at 146.52 MHz with a peak phase deviation of 45° . Evaluate the exact magnitude spectra of the PM signal if $A_c = 1$. Sketch your result. Using Carson's rule, evaluate the approximate bandwidth of the PM signal and see if it is a reasonable number when compared with your spectral plot.
- 5-32 A 1-kHz sinusoidal signal frequency modulates a carrier at 146.52 MHz with a peak deviation of 5 kHz. Evaluate the exact magnitude spectra of the FM signal if $A_c = 1$. Sketch your result. Using Carson's rule, evaluate the approximate bandwidth of the FM signal and see if it is a reasonable number when compared with your spectral plot.
- 5-33 The calibration of a frequency deviation monitor is to be verified by using a Bessel function. An FM test signal with a calculated frequency deviation is generated by frequency modulating a sine wave onto a carrier. Assume that the sine wave has a frequency of 2 kHz and that amplitude of the sine wave is slowly increased from zero until the discrete carrier term (at the center of the FM signal) reduces to zero, as observed on a spectrum analyzer. What is the peak frequency deviation of the FM test signal when the discrete carrier term is zero? Suppose that amplitude of the sine wave is increased further until this discrete carrier term appears, reaches a maximum, and then disappears again. What is the peak frequency deviation of the FM test signal now?
- 5-34 A frequency modulator has a modulator gain of 10 Hz/V and the modulating waveform is

$$m(t) = \begin{cases} 0, & t < 0 \\ 5, & 0 < t < 1 \\ 15, & 1 < t < 3 \\ 7, & 3 < t < 4 \\ 0, & 4 < t \end{cases}$$

- Plot the frequency deviation in hertz over the time interval $0 < t < 5$.
- Plot the phase deviation in radians over the time interval $0 < t < 5$.

2 Key solution

EE 443)

HW # 7

page 1

Key

Drill prob. # 3.2)

$$s_{AM}(t) = A_c [1 + K_a m(t)] \cos 2\pi f_c t$$

where $m(t) = A_m \cos 2\pi f_m t$ sinusoidal modulating wave

$$s_{AM}(t) = A_c [1 + K_a A_m \cos 2\pi f_m t] \cos 2\pi f_c t \quad f_c \gg f_m$$

$$K_a A_m = 20\% = 0.2 \Rightarrow$$

$$s_{AM}(t) = A_c [1 + 0.2 \cos 2\pi f_m t] \cos 2\pi f_c t$$

$$= A_c \cos 2\pi f_c t + A_c M \cos 2\pi f_m t \cos 2\pi f_c t$$

$$= \underbrace{A_c \cos 2\pi f_c t}_{\text{carrier}} + \frac{A_c M}{2} \left\{ \underbrace{\cos[2\pi(f_c + f_m)t]}_{\text{U.S.B}} + \underbrace{\cos[2\pi(f_c - f_m)t]}_{\text{L.S.B}} \right\}$$

$$\text{Thus: } P_c = \frac{A_c^2}{2}$$

$$P_{USB} = P_{LSB} = \frac{\left(\frac{A_c M}{2}\right)^2}{2} = \frac{A_c^2 M^2}{8} = \frac{A_c^2 (0.2)^2}{8} = \frac{A_c^2}{200}$$

That is carrier has 98% of total power and each sideband has 1% the total power.

Drill prob. # 3.4)

$$a) \quad v_1(t) = A_c \cos 2\pi f_c t + m(t) \quad (1)$$

$$v_2(t) = a_1 v_1(t) + a_2 v_1^2(t) \quad (2)$$

$$\Rightarrow v_2(t) = a_1 (A_c \cos 2\pi f_c t + m(t)) + a_2 (A_c \cos 2\pi f_c t + m(t))^2$$

EE 443

HW # 7

page 2

(will prob. # 3.3) Assume

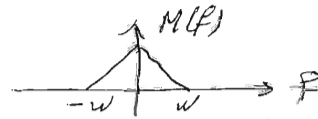

In general $s_{AM}(t) = A_c [1 + K_a m(t)] \cos 2\pi f_c t$

$$S_{AM}(f) = \frac{A_c}{2} [\delta(f-f_c) + \delta(f+f_c)] + \frac{A_c K_a}{2} [M(f-f_c) + M(f+f_c)]$$

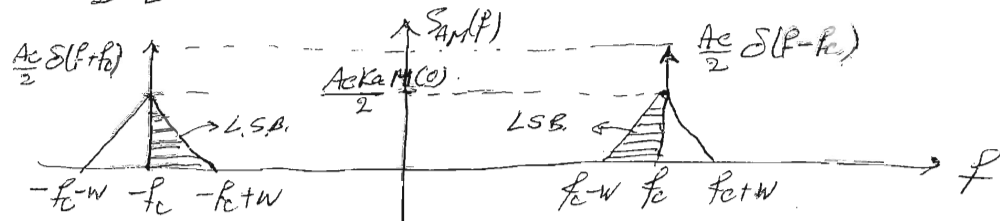

From the plot of $S_{AM}(f)$ we see that to avoid the overlapping of L.S.B frequencies it must

$$f_c - w > 0 \Rightarrow f_c > w$$

3.18)

Given :

$$\begin{cases} m(t) = 20 \cos(2\pi t) \text{ volts} \\ c(t) = 50 \cos(100\pi t) \text{ volts} \\ \mu = A_m K_a = 75\% = 0.75 \\ R = 100 \Omega \end{cases}$$

$$\begin{aligned} b) \quad s_{AM}(t) &= A_c [1 + K_a m(t)] \cos 2\pi f_c t = 50 \left[1 + \frac{K_a \cdot 20 \cos 2\pi t}{\mu} \right] \cos 100\pi t \\ &= 50 \cos(100\pi t) + 50 \times 0.75 \cos(100\pi t) \cos(2\pi t) \\ &= 50 \cos(100\pi t) + \frac{37.5}{2} \left\{ \cos(102\pi t) + \cos(98\pi t) \right\} \end{aligned}$$

$$P_{tot} = \frac{(50)^2}{2R} + 2 \times \frac{\left(\frac{37.5}{2}\right)^2}{2R} = \frac{2500}{200} + \frac{1406.25}{400} = 16.0156 \text{ watts}$$

EE 443

HW #7

page 3

5-2. (a.) Cont'd

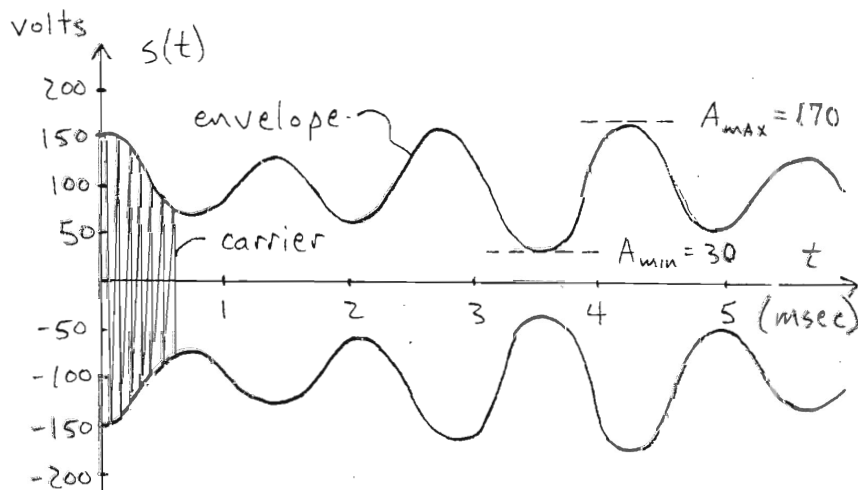

$$(b.) \quad \frac{170 - 30}{2(100)} (100) = \underline{\underline{70\% \text{ modulation}}}$$

$$(c.) \quad G(f) = \delta(f) + m(f)$$

$$= \delta(f) - j \frac{(0.2)}{2} [\delta(f-f_1) - \delta(f+f_1)] \\ + \frac{(0.5)}{2} [\delta(f-f_2) + \delta(f+f_2)]$$

$$S(f) = \frac{A_c}{2} [G(f-f_c) + G^*(-f-f_c)]$$

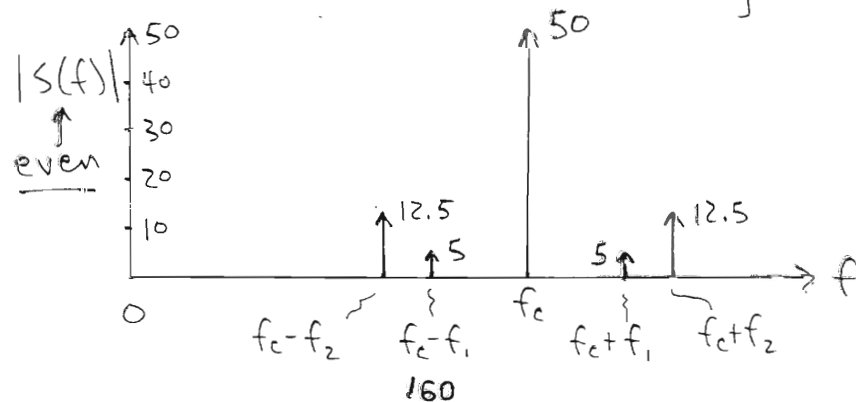

3 my graded HW

HW # 7
EE 443
Oct 30, 2008
Fall 2008

NASSER ABBASI.

Problems 3.2 }
3.3 } Text Book.
3.4 }
3.18 }
5.2 (Handout)
(Hard)

Problem 3.2 (Book page 110)

For particular case of AM using sinusoidal modulating wave, the percentage modulation is 20%. Calculate average power in (a) the carrier and (b) each side frequency.

Answer

in this case $m(t) = A_m \cos(2\pi f_m t)$

and $c(t) = A_c \cos(2\pi f_c t)$

and $s(t) = A_c [1 + K_a m(t)] \cos(2\pi f_c t)$

$$= A_c [1 + K_a A_m \cos(2\pi f_m t)] \cos(2\pi f_c t)$$

let $K_a A_m = \mu$

$$s(t) = A_c [1 + \mu \cos(2\pi f_m t)] \cos(2\pi f_c t)$$

$$= A_c \cos(2\pi f_c t) + A_c \mu \cos(2\pi f_m t) \cos(2\pi f_c t) \quad \text{--- (1)}$$

but $\cos(\omega_m t) \cos(\omega_c t) = \frac{1}{2} (\cos(\omega_m + \omega_c)t + \cos(\omega_m - \omega_c)t)$

so (1) becomes

$$s(t) = A_c \cos \omega_c t + \frac{A_c \mu}{2} \left(\underbrace{\cos(\omega_m + \omega_c)t}_{\text{upper side band}} + \underbrace{\cos(\omega_c - \omega_m)t}_{\text{lower side band}} \right)$$

So, power in $s(t) = \frac{1}{2} A_c^2 + \frac{1}{2} \left(\frac{A_c \mu}{2} \right)^2 \times 2$

so (a) power in carrier = $\boxed{\frac{1}{2} A_c^2}$

(b) power in lower side and upper side = $\frac{1}{2} \frac{A_c^2 \mu^2}{4} = \frac{A_c^2 \mu^2}{8} \sqrt{\quad}$

but $\mu = 0.2$, hence power = $\frac{A_c^2 (0.2)^2}{8} = \boxed{\frac{A_c^2}{400}}$

Then power in ^{both} side band to power in carrier is

$$\frac{\frac{1}{400} + \frac{1}{400}}{\frac{1}{2}} = \sqrt{\quad} \%$$

#3.3

in AM, spectral overlap is said to occur if lower sideband for positive frequencies overlaps with its image for negative frequencies. what conditions must the modulated wave satisfy if we were to avoid spectral overlap? Assume $m(t)$ is low-pass kind with bandwidth W .

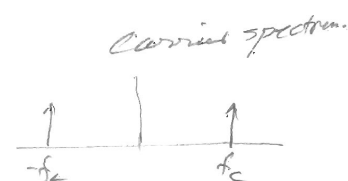
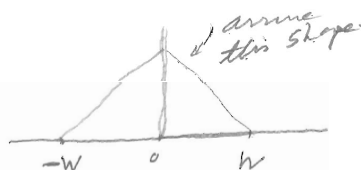
Answerspectrum of $m(t)$ 

modulated carrier:

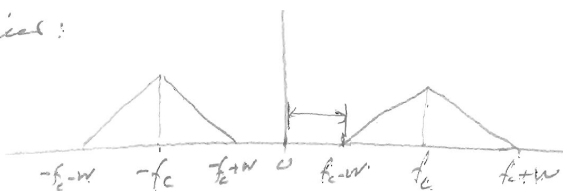

So to avoid spectral overlap, we need. $f_c - W > 0$

or $f_c > W$

this insures that modulated carrier sidebands do not overlap in the frequency domain.

problem 3.4

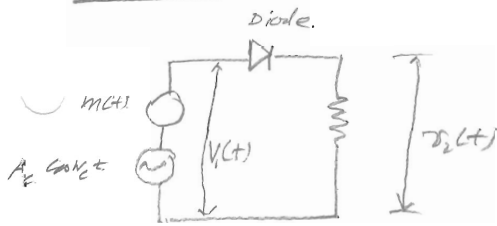

$$v_1(t) = A_c \cos \omega_c t + m(t)$$

$$v_2(t) = a_1 v_1(t) + a_2 v_1^2(t)$$

a_1, a_2 are constants.

a) determine spectral content of $v_2(t)$.

$$\begin{aligned} v_2(t) &= a_1 (A_c \cos \omega_c t + m(t)) + a_2 (A_c \cos \omega_c t + m(t))^2 \\ &= a_1 A_c \cos \omega_c t + a_1 m(t) + a_2 (A_c^2 \cos^2 \omega_c t + m^2(t) + 2 A_c \cos \omega_c t m(t)) \\ &= \cos \omega_c t [a_1 A_c + 2 a_2 A_c m(t)] + a_1 m(t) + a_2 A_c^2 \cos^2 \omega_c t + a_2 m^2(t) \end{aligned}$$

$$= a_1 A_c \left[1 + \frac{2 a_2}{a_1} m(t) \right] \cos \omega_c t + a_1 m(t) + a_2 A_c^2 \frac{1 + \cos 2 \omega_c t}{2} + a_2 m^2(t)$$

Now assume $m(t)$ is limited to $-W \leq f \leq W$.

So spectrum of $m^2(t)$ can be found as follows:

$$\begin{aligned} g(t) &= m^2(t) \\ &= m(t) m(t) \end{aligned}$$

$$G(f) = M(f) \otimes M(f)$$

Since $M(f)$ has bandwidth of W , then due to convolution, $G(f)$ will have bandwidth of $2W$.

Therefore $v_2(t)$ will have the following spectrum:

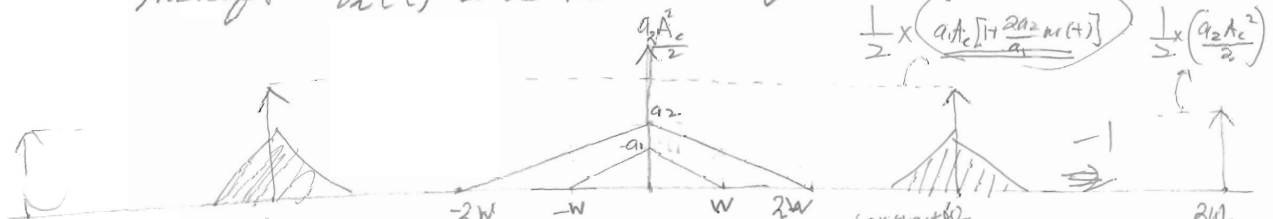

$$v_2(t) = a_1 A_c \left[1 + \frac{2 a_2}{a_1} m(t) \right] \cos \omega_c t + a_1 m(t) + a_2 A_c^2 \frac{1 + \cos 2 \omega_c t}{2} + a_2 m^2(t)$$

$-W_c < f < W_c$ $-W < f < W$ $-2W < f < 2W$ $-2W_c < f < 2W_c$

Statement

Th. part (b)

(b) now $s_2(t)$ is inputted to band-pass filter.

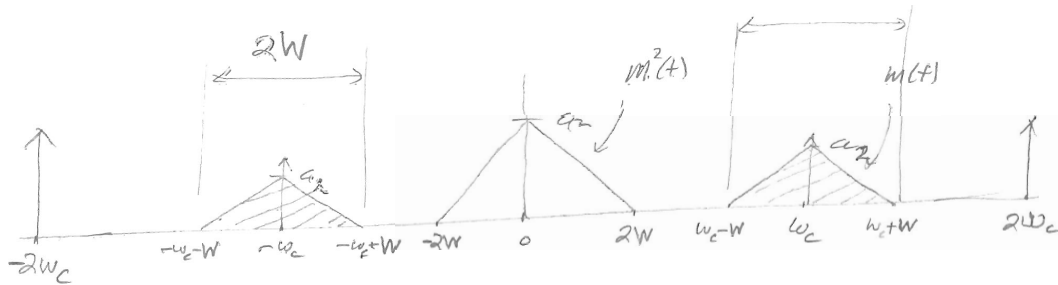

then we see that the modulated carrier range of frequencies is
 $f_c - W < f < f_c + W$ in the positive side

$-f_c - W < f < -f_c + W$ in the negative side
 i.e. cutoff frequencies $f_c - W$ and $f_c + W$

the above is the range of frequencies of the shaded part of the spectrum, which carries the modulated carrier by $m(t)$ signal. only. \Rightarrow That is: $a_1 A_c [1 + \frac{2a_2}{a_1} m(t)] \cos \omega_c t$.

c) after band-pass, we obtain this range must be $> 3W$

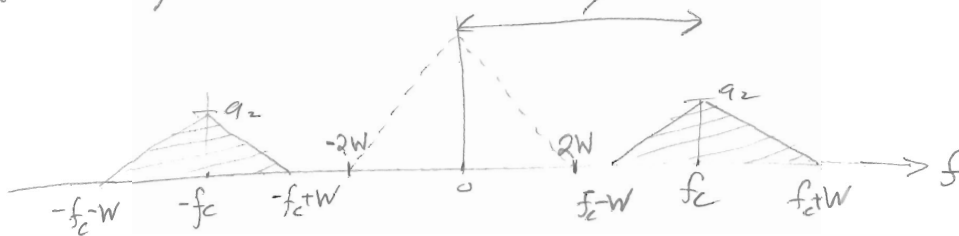

so, to avoid overlapping with $m^2(t)$ spectrum, f_c must be $> 3W$.
 where $2W$ are due to $m^2(t)$ spectrum originally and an additional W comes from the $m(t)$ bandwidth itself.

3.18

Consider $m(t) = 20 \cos(2\pi t)$ volts.

and carrier

$$c(t) = 50 \cos(100\pi t) \text{ volts}$$

- (a) sketch to scale the resulting AM wave for $\mu = .75$
 (b) find power developed across load of 100 ohms due to this AM wave.

Answer

$$s(t) = A_c [1 + \mu m(t)] \cos \omega_c t$$

where $A_c = 50$, $\omega_c = 100\pi$.

$$s(t) = 50 [1 + .75 \cos 2\pi t] \cos(100\pi t)$$

So the envelope will have a max value of 87.5 and
 a min value of 37.5

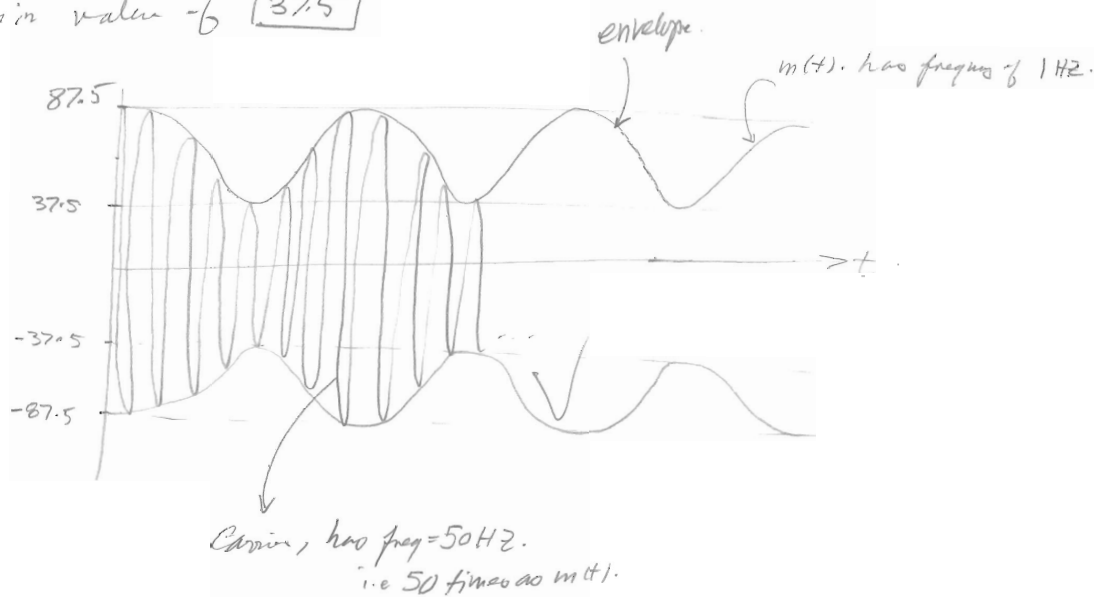

Please see more
 accurate plot next
 page.

```
In[7]:= s[t_] := 50 (1 + .75 Cos[2 Pi t]) Cos[100 Pi t]
Plot[s[t], {t, 0, 1}, PlotRange -> All]
```

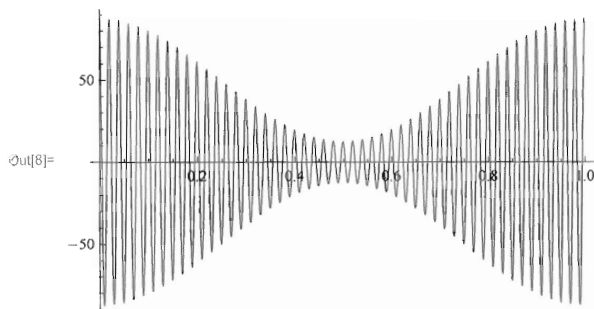

$$\begin{aligned}
 b) \quad s(t) &= 50 [1 + 0.75 \cos(2\pi t)] \cos(100\pi t) \\
 &= 50 \cos(100\pi t) + 37.5 \cos(2\pi t) \cos(100\pi t) \\
 &= 50 \cos(100\pi t) + \frac{37.5}{2} (\cos(102\pi t) + \cos(98\pi t))
 \end{aligned}$$

So power across 1Ω from $C(t)$ is $\frac{50^2}{2}$ watt. and power across

1Ω from side bands is $2 \times \frac{1}{2} \left(\frac{37.5}{2}\right)^2$ watt. $R=100\Omega$.

So Total ^{average} power across 1Ω is $1,425.78$ watt. \star you have 2 cosine function

So Total power developed in 100Ω is $142,500$ watt or 142.5 kW

$$\frac{(50)^2}{200} + 2 \times \frac{\left(\frac{37.5}{2}\right)^2}{200} = 16.0156$$

16.0156 W

Problem 5.2 from Handout

AM transmitter is modulated with signal $m(t) = 0.2 \sin \omega_1 t + 0.5 \cos \omega_2 t$

where $f_1 = 500 \text{ Hz}$ and $f_2 = 500\sqrt{2} \text{ Hz}$, $A_c = 100$. Assume AM signal is fed into 50Ω load.

- Sketch AM waveform
- What is modulation %?
- Evaluate and sketch the spectrum of the AM waveform

$$s(t) = A_c [1 + K_a A_m m(t)] \cos \omega_c t$$

$$A_m m(t) = 0.2 \sin 2\pi f_1 t + 0.5 \cos 2\pi f_2 t$$

the largest frequency in $m(t)$ is 500 Hz . $\therefore f_c \gg W$.

$$\text{let } f_c = 500 \text{ Hz}$$

$$\therefore s(t) = 100 [1 + K_a (0.2 \sin 1000\pi t + 0.5 \cos 1000\sqrt{2}\pi t)] \cos(1000\pi t)$$

We need $|K_a m(t)| < 1$ to avoid overmodulation.

We can write $s(t)$ as follows

$$s(t) = 100 [1 + \mu m(t)] \cos \omega_c t$$

$$\text{where } \mu = \frac{A_{\max} - A_{\min}}{A_{\max} + A_{\min}}$$

where $A_{\max} = \text{max value of } 0.2 \sin \omega_1 t + 0.5 \cos \omega_2 t$ and

$A_{\min} = \text{min value of } \quad \quad \quad "$

so to find A_{\max} and A_{\min} we do

$$\frac{dm(t)}{dt} \text{ and set to zero.}$$

OK,

$$\frac{dm(t)}{dt} = (0.2 \cos(\omega_1 t)) \cdot \omega_1 - (0.5 \sin(\omega_2 t)) \omega_2 = g(t)$$

$$\therefore g(t) = 0 \Rightarrow (-2 \cos 1000\pi t) \cdot 1000\pi - (0.5 \sin 1000\sqrt{2}t) \cdot 1000\sqrt{2}\pi = 0$$

$$\text{So } g(t) = 0 \Rightarrow .2 \cos 1000\pi t - \sqrt{2} \frac{1}{2} \sin 1000\sqrt{2}t = 0$$

i.e find where the above has root. that

t will give either max or min.

once the above is done, we can find

it.

a sketch will be as follows:



Plen see exact
plot on next page

```
In[35]:= f[t_] := 100 (1 + (.2 Sin[2 Pi 500 t]) +
Plot[f[t], {t, 0, .03}, PlotRange -
```

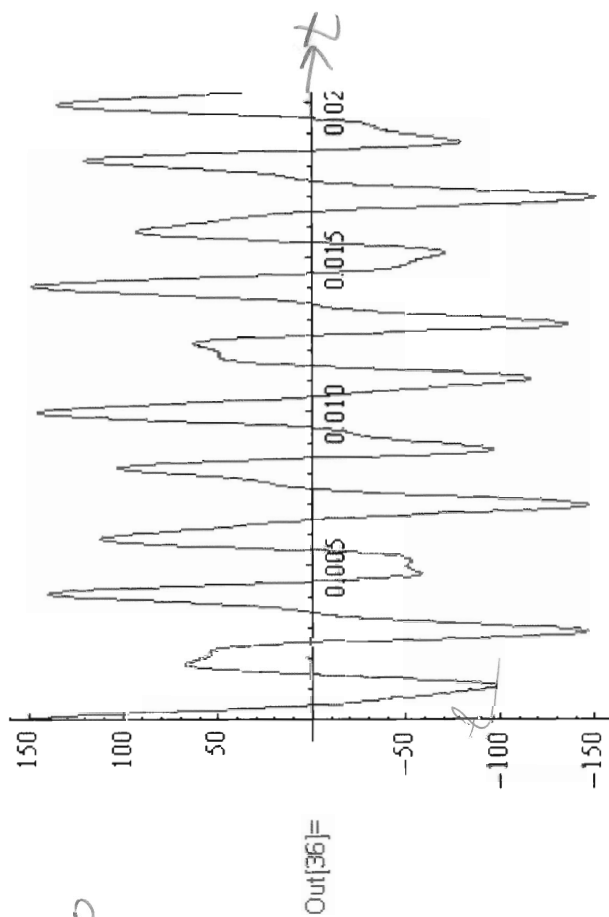

Ps. I used $K_a = 1$ to
Plot this AM
Wave form.

Part b to find modulation % , this is M .

$$M = \frac{A_{max} - A_{min}}{A_{max} + A_{min}}$$

→ you should find A_{max} and A_{min} .

I described to find this earlier. (need to take derivative of $w(t)$ wr. time and set to zero to find A_{max}/A_{min}).

I did not do this as the generated equation is nonlinear and I am not sure if my approach is correct at this time.

(c) to find the spectrum:

$$s(t) = A_c [1 + K_a (.2 \sin \omega_1 t + .5 \cos \omega_2 t)] \cos \omega_c t$$

note: There are 2 different Harmonics in $w(t)$.

$$= A_c \cos \omega_c t + A_c K_a .2 \sin \omega_1 t \cos \omega_c t + A_c K_a .5 \cos \omega_2 t \cos \omega_c t$$

$$= A_c \cos \omega_c t + .2 A_c K_a \frac{1}{2} (\sin(\omega_c + \omega_1)t + \sin(\omega_c - \omega_1)t)$$

$$+ .5 A_c K_a \frac{1}{2} (\cos(\omega_c + \omega_2)t + \cos(\omega_c - \omega_2)t)$$

So spectrum is

