

my Latex and Tex4ht cheat sheet

Nasser M. Abbasi

August 11, 2024

Compiled on August 11, 2024 at 5:50pm [public]

Contents

1	general links	3
2	Math fonts status in tex4ht	9
3	Latex specific HowTo	11
4	TeX4ht cheat sheet	77
5	Tikz notes	119
6	Using Scientific word	131
7	Trying latexml	135
8	Trying pdf2htmlEX	137

CHAPTER 1

GENERAL LINKS

1.1 Latex

1. tex4ht change log <https://tug.org/tex4ht/changelog.html>
2. good site to type latex and see the output <https://khan.github.io/KaTeX/>
3. lwrap package examples of lwrap package, converts latex to html. Never tried it. Should try it sometime.
4. <http://www.practicallyefficient.com/2017/10/13/from-boiling-lead-and-black-art.html> article "An essay on the history of mathematical typography" by Eddie Smith.
5. <https://alternativeto.net/software/mathtype/> contains links to many small Latex utilities, all software similar to latex or uses math typesetting.
6. <http://quicklatex.com/> A nice web site. Allows one to throw latex code and see the output on the fly. This can be handy for testing quick Latex code.
7. http://www.gust.org.pl/projects/e-foundry/math/gust_e-foundry-math_fonts-presentation.pdf "A comparison of different OTF Math fonts in use with different engines capable of typesetting mathematics"
8. <http://maverick.inria.fr/~Nicolas.Holzschuch/texmath.html> site that compares 4 different latex fonts for number of equations
9. Martin Scharrer Standalone package page
10. tex live source
11. .4ht files in source control for tex4ht

12. All of TeXLive distributions since 1996
13. Latex pre test <http://tug.org/texlive/pretest.html>
14. announcements <http://tug.org/texlive/>
15. LuaLatex PDF document
16. tex4ht command line options
17. Free Graphics Software for the TeX, LaTeX, and PSTricks Community
18. Google Sketchup 3D Warehouse for airplane
19. Drawing on an image with TikZ
20. book published by TUG
21. pdf2htmlEX
22. Entering bugs for htlatex
23. try latex online <http://arachnoid.com/latex/>
24. shows Latex matrices http://latex.wikia.com/wiki/Matrix_environments
25. using 3D in tikz and asymptote <https://tex.stackexchange.com/questions/39577/what-are-the-relative-strengths-of-tikz-and-asymptote>
26. LaTeX and Friends book page. <http://cweb.ucc.ie/~dongen/LAF/LAF.html>
27. "This is the TeX showcase, edited by Gerben Wierda. It contains extreme examples of what you can do with TeX, " <http://www.tug.org/texshowcase/>
28. Asymptote: The Vector Graphics Language
29. Wikipedia:LaTeX symbols
30. Latex search The Springer LaTeX search lets you search through over LaTeX code snippets to find the equation you need.
31. List of commands manipulating horizontal and vertical spaces, and holding material in boxes <http://www.personal.ceu.hu/tex/spacebox.htm>
32. Latex cookbook <http://www.personal.ceu.hu/tex/cookbook.html>
33. TeX Live – Quick install directions <http://www.tug.org/texlive/quickinstall.html>

34. hints to squeeze spaces in Latex <http://www-h.eng.cam.ac.uk/help/tpl/textprocessing/squeeze.html>
35. Host math, type Latex online and see output on screen <http://www.hostmath.com/>
36. LaTeX/Special Characters https://en.wikibooks.org/wiki/LaTeX/Special_Characters
37. The AoPS Wiki , has useful Latex pages under tutorials http://www.artofproblemsolving.com/wiki/index.php/Main_Page
38. Blog entry on Latex multiline equations
39. list of all Latex errors <http://www.eng.fsu.edu/~dommelen/l2h/errors.html>
40. Latex title pages templates
41. Dickimaw LaTeX Books <http://dickimaw-books.com/latex/index.html>
42. hostmath, try Latex online <http://www.hostmath.com/>
43. Producing HTML and PDF files with LaTeX, from University of Cambridge <http://www-h.eng.cam.ac.uk/help/tpl/textprocessing/makingWWWdocs.html>
44. notes on how to handle images in latex <http://www.artofproblemsolving.com/wiki/index.php/LaTeX:Pictures>
45. Hamline University Physics Department Latex Equation Editor <http://sites.hamline.edu/~arundquist/equationeditor/>
46. Andrew Roberts tutorials on Latex <http://www.andy-roberts.net/writing/latex>
47. LaTeX Spaces and Boxes. Commands manipulating horizontal and vertical spaces, and holding material in boxes: <http://www.personal.ceu.hu/tex/spacebox.htm>
48. describes latex standard environments <http://www.personal.ceu.hu/tex/environ.htm>
49. collection of Latex links <http://www.personal.kent.edu/~rmuhamma/Systems/latex.html>
50. LATEX, MATHML, AND TEX4HT: TOOLS FOR CREATING ACCESSIBLE DOCUMENTS (A BRIEF TUTORIAL) by JACEK POLEWCZAK <http://ww>

w.csun.edu/~hcmth008/mathml/acc_tutorial.pdf

51. LaTeX: from quick and dirty to style and finesse More mathematics by Tony Roberts <http://www.utexas.edu/ogs/etd/LaTeX/Resources/from.quick+dirty/ltxmaths.html>
52. User's Guide for the amsmath Package (Version 2.0) American Mathematical Society 1999-12-13 (revised 2002-02-25) <ftp://ftp.ams.org/pub/tex/doc/amsmath/amslldoc.pdf>
53. Latex: Squeezing the Vertical White Space "Here are some tips on how to compress your paper vertically by minimizing white space gaps between elements" <http://www.terminally-incoherent.com/blog/2007/09/19/latex-squeezing-the-vertical-white-space/>
54. more on squeezing space, CAM.AC.UK article <http://www-h.eng.cam.ac.uk/help/tpl/textprocessing/squeeze.html>
55. Latex templates
56. How to find number of pages in pdf file
57. Strategies for including graphics in LATEX documents
58. class notes on using IPE and Inkscape with Latex
59. notes on using IPE gradphic editor for latex and how use style sheets for it
60. Konrad Siek LaTeX Formal Methods Reference
61. Latex templates IEEE and here
62. Formatting IEEE Papers
63. view latex fonts online
64. How to see macro expansion
65. tweets for tex stackexchange
66. style sheets for minted package for code listing

1.2 Context links

1. <http://www.pragma-ade.com/general/manuals/details.pdf>
2. main page http://wiki.contextgarden.net/Main_Page
3. hello world in context http://wiki.contextgarden.net/Hello_world
4. http://wiki.contextgarden.net/ConTeXt_Standalone

1.3 LuaTeX programming

1. Lua main programming language page, manuals, etc... <http://www.lua.org/>
2. luatex reference manual in pdf <http://www.luatex.org/svn/trunk/manual/luatexref-t.pdf>
3. [how-to-run-a-program-inside-lualatex](#)
4. [what-is-a-simple-example-of-something-you-can-do-with-luatex](#)
5. <http://tex.stackexchange.com/questions/17789/printf-style-number-formatting-in-latex-printf-style-number-formatting-in-latex> Has lua coding example
6. [lualatex-for-dummies-basic-directlua-use](#)
7. [Writing Lua in TeX](#)
8. [Programming in LuaTeX in Context](#)
9. [Wiki LuaTeX](#)
10. [LuaTeX web site](#)
11. http://wiki.luatex.org/index.php/TeX_without_TeX
12. [Lua for Python programmers article http://the4thwiki.com/lua/index.html](http://the4thwiki.com/lua/index.html)
13. [luacode package https://www.ctan.org/pkg/luacode?lang=en](https://www.ctan.org/pkg/luacode) the following table is from the above document.

The following table summarizes how to use special characters with the various commands and environments.

	<code>\luadirect</code>	<code>\luaexec</code>	<code>luacode</code>	<code>luacode*</code>
Macros	Yes	Yes	Yes	No
Single backslash	<code>\string\</code>	<code>\string\</code>	<code>\string\</code>	Just <code>\</code>
Double backslash	<code>\string\\</code>	<code>\\</code>	<code>\\</code>	<code>\\</code>
Tilde	<code>\string~</code>	<code>~</code>	<code>~</code>	<code>~</code>
Sharp	<code>\string#</code>	<code>\#</code>	<code>#</code> (or <code>\#</code>)	<code>#</code>
Percent	No easy way	<code>\%</code>	<code>%</code> (or <code>\%</code>)	<code>%</code>
TeX comments	Yes	Yes	No	No
Lua line comments	No	No	Yes	Yes

CHAPTER 2

MATH FONTS STATUS IN TEX4HT

status

LATEX SPECIFIC HOWTO

3.1 How to install TL 2022 pre test?

went to `http://ftp.math.utah.edu/pub/tlpretest/` and downloaded the file `install-tl-unx.tar.gz` to new folder. Then did `gunzip` on it then `tar -xvf` on the tar file. Then `cd` to the install folder that is created.

Now to do the actual installation it is important to type this command by giving `-repository` option else it will not work, since I have TL 2021 installed and I am trying to install TL 2022. So used this command

```
sudo ./install-tl -repository http://www.math.utah.edu/pub/tlpretest/
```

Now it will make new folder for TL 2022 and install it there alongside the TL 2021.

3.2 How to increase the setting `dest_names_size` using `lualatex`?

This applies to any one using `lualatex` and encounters the dreaded error

```
sorry [number of destination names (dest_names_size)=131072]
```

Which happens due to large document which has many destination names in it.

Notice that changing `dest_names_size` in `texmf.cnf` has no effect on the above as `lualatex` uses `sup_dest_names_size` for the limit of destination names and not `dest_names_size` which is used it seems by `pdflatex` only. Thanks to Marcel Krüger for this hint and pointing this out.

The solution I did is to download luatex sources from <https://github.com/TeX-Live/luatex> ~~<https://gitlab.lisn.upsaclay.fr/texlive/luatex>~~ (note, as of August 2024, use this new link, the github one is old). Click on code button above and download the zip file.

Now extract the ZIP file into a temporary folder. The exact file to download from above is the zip file

`wget https://github.com/TeX-Live/luatex/archive/refs/heads/trunk.zip` to download the zip file directly to some TMP folder and then extract the zip file. This will create new folder called `luatex-trunk`.

Edit the file `pdfdest.h` in the source tree inside. It is located in

```
>pwd
/home/me/TMP/luatex-trunk/source/texk/web2c/luatexdir/pdf
>ls -lrt pdfdest.h
-rw-r--r-- 1 me me 2167 May 27 18:12 pdfdest.h
```

There you will find the following lines

```
# define inf_dest_names_size 1000 /* min size of the destination names table for PDF output
# define sup_dest_names_size 131072 /* max size of the destination names table for
```

I changed `sup_dest_names_size` which is now 2^{17} to $2^{18} = 262144$. Saved the file.

Now at the top level folder where you extracted luatex, there is a file called `build.sh`

```
>pwd
/home/me/TMP/luatex-trunk
>ls -l build.sh
-rwxr-xr-x 1 me me 11900 May 27 18:12 build.sh
```

Edit the above file and change `BUILDLUAHB=FALSE` to `BUILDLUAHB=TRUE` This is so it builds `luahbtex` in addition to `luatex`. Also make sure to uncomment the lines

```
#export CFLAGS="-D_FORTIFY_SOURCE=2 -O3"
#export CXXFLAGS="-D_FORTIFY_SOURCE=2 -O3"
```

By removing the `#` from the front to now look like this.

```
export CFLAGS="-D_FORTIFY_SOURCE=2 -O3"
```

```
export CXXFLAGS="-D_FORTIFY_SOURCE=2 -O3"
```

This is important, else the generated binaries will run very slow.

Now type `./build.sh`

When done there will be two binaries `luahtex` and `luatex` in folder

```
>pwd
/home/me/TMP/luatex-trunk/build/teXk/web2c
-rwxr-xr-x  1 me me 7960728 Jul  7 20:42 luatex
-rwxr-xr-x  1 me me 9376072 Jul  7 20:42 luahtex
```

This completes the first phase. The second phase is to copy the above files (as root) from the above folder to your texLive installation.

On my system linux ubuntu I became root and copied the above 2 files to `/usr/local/texlive/2022/bin/linux/` overwriting the original files (made a backup copy before doing this just in case)

Now the final step is to rebuild texmf files using the command

```
sudo -E env "PATH=$PATH" fmtutil-sys --all
```

Make sure to run it as above using root! as shown above. Do not do

```
#DO NOT DO THIS, USE THE ABOVE INSTEAD
sudo fmtutil-sys --all
```

As this might fail if root does not know where your TL path is and this can cause problems. (This happened to me).

That is all. Now `luatex` will have its destination names set at 262144 instead of 131072 hardcoded into the source code.

Future versions of `Lualatex` should really make this parameter available to users to modify without having to do this each time but I asked the `luatex` mailing list to do this and was just ignored.

<https://www.mail-archive.com/luatex@tug.org/msg07512.html>

I guess no body cares about generating large documents so it does not affect others.

May be in the future this can be changed using `/usr/local/texlive/2022/texmf.cnf`

Note: During doing this, I was getting an error

```
>lualatex foo.tex
This is LuaHBTeX, Version 1.13.2 (TeX Live 2021)
  restricted system commands enabled.

(Fatal format file error; I'm stymied)>
```

If you get such an error, It turned out there was a hidden folder called `$HOME/.texlive2022` in my home folder. Simply deleting this folder and trying again the `texmf` command above solved this problem.

It seems newer versions of TL creates this hidden folder which I never knew about.

Now your document can have up to 262144 destination names available instead of the current low value.

3.3 How to install garamond fonts

THis was complicated., so I wrote the what I did below. In the latex file use this. THis is all on a Linux system. I am using `lualatex` and not `pdflatex`.

```
...
\usepackage[T1]{fontenc}
\usepackage[urw-garamond]{mathdesign}
....
```

But just typing `lualatex foo.tex` gives this error

```
! error: (type 1): cannot open file for reading 'ugmm8a.pfb'
```

These fonts do not come with tex live. So the following instructions shows what to do to get them.

On a terminal, typed, from some empty folder

```
wget https://tug.org/fonts/getnonfreefonts/install-getnonfreefonts
```

This downloaded `install-getnonfreefonts` in the folder.

Next, typed `sudo "PATH=$PATH" ./install-getnonfreefonts --sys --all`

and the result is

```

Detected System: x86_64-linux
Detected Installation: /usr/local/texlive/2018
mkdir /usr/local/texlive/2018/texmf-dist/scripts/getnonfreefonts ... [done]
Installing texmf-dist/scripts/getnonfreefonts/getnonfreefonts.pl ... [done]
Installing texmf-dist/doc/man/man1/getnonfreefonts.1 ... [done]
Installing texmf-dist/doc/man/man1/getnonfreefonts.man1.pdf ... [done]
md5sum: a9e772165e8fdb620bcf9c75c17facda getnonfreefonts.pl ... [ok]
md5sum: 49be4444054d85b6037d237552a7cea1 getnonfreefonts.1 ... [ok]
md5sum: f825d523d686dbecdc787535b40f09d0 getnonfreefonts.man1.pdf ... [ok]
Fixing File Permissions ... [done]
Creating symlink in 'bin/x86_64-linux' ... [done]
mktexlsr: Updating /usr/local/texlive/2018/texmf-dist/ls-R...
mktexlsr: Done.

```

Next, typed

```
sudo "PATH=$PATH" /usr/local/texlive/2018/bin/x86_64-linux/getnonfreefonts --sys garamond
```

and it said

```

--2018-09-20 16:26:21-- https://www.tug.org/~kotucha/getnonfreefonts/getfont.pl
Resolving www.tug.org (www.tug.org)... 91.121.174.77
Connecting to www.tug.org (www.tug.org)|91.121.174.77|:443... connected.
HTTP request sent, awaiting response... 200 OK
Length: 33001 (32K)
Saving to: getfont.pl

getfont.pl                               100%[=====]

2018-09-20 16:26:22 (296 KB/s) - getfont.pl saved [33001/33001]
-----
Installation directory: /usr/local/texlive/texmf-local
-----
=====
Package 'garamond':
=====

Downloading 'http://mirrors.ctan.org/fonts/urw/garamond.zip'
--2018-09-20 16:26:22-- http://mirrors.ctan.org/fonts/urw/garamond.zip
Resolving mirrors.ctan.org (mirrors.ctan.org)... 2a01:488:67:1000:b01c:36b8:0:1, 176.28.54.1

```

```

Connecting to mirrors.ctan.org (mirrors.ctan.org)|2a01:488:67:1000:b01c:36b8:0:1|:80... conn
HTTP request sent, awaiting response... 302 Found
Location: http://mirror.las.iastate.edu/tex-archive/fonts/urw/garamond.zip [following]
--2018-09-20 16:26:30-- http://mirror.las.iastate.edu/tex-archive/fonts/urw/garamond.zip
Resolving mirror.las.iastate.edu (mirror.las.iastate.edu)... 129.186.138.51
Connecting to mirror.las.iastate.edu (mirror.las.iastate.edu)|129.186.138.51|:80... connecte
HTTP request sent, awaiting response... 200 OK
Length: 393158 (384K) [application/zip]
Saving to: garamond.zip

garamond.zip                               100%[=====]
2018-09-20 16:26:36 (708 KB/s) - garamond.zip saved [393158/393158]

                                                    [download done]
Checking integrity of file 'garamond.zip'...           [ok]

a60beaf12c12c69eeb8fdc82bd481949  garamond.zip           [MD5sum ok]

Extracting 'ugm.zip' from 'garamond.zip'...           [done]
Extracting 'ugm.zip'...                               [done]
Extracting 'garamond.zip'...                          [done]
Installing 'ugm.map'...updmap [WARNING]: resetting $HOME value (was /home/me) to root's actu
Creating new config file /usr/local/texlive/2018/texmf-config/web2c/updmap.cfg
                                                    [done]
Running 'mktexlsr /usr/local/texlive/texmf-local >/dev/null 2>/dev/null' ... [done]

Updating map files (updmap-sys). Be patient...updmap [WARNING]: resetting $HOME value (was /
                                                    [done]

```

Finally, now I can compile the latex file using `lualatex foo.tex` with the above packages, and not get the error showed at earlier above.

These look like nice fonts.

3.4 How to draw faces in Latex

Found this on the net. I wonder how many such faces can one draw in Latex?

`\widehat{\dbinom{\odot_{\text{v}}}{\odot}}{\wr}` gives



3.5 How to see more context where the error generated came from?

Add `\errorcontextlines=200` in preamble, that will display more lines around where the error shows. (thanks to Ulrike Fischer)

3.6 How to include image in landscape mode?

```
\documentclass[11pt]{article}%
\usepackage{graphicx}
\usepackage{rotating}
\begin{document}

\begin{sidewaysfigure}[!htbp]
\includegraphics[width=1\textwidth]{image}
\end{sidewaysfigure}

\end{document}
```

3.7 How to spell check Latex document?

```
aspell -t -c file.tex
```

3.8 How to obtain external file information about Latex build

1. use `\RequirePackage{snapshot}` see <http://tex.stackexchange.com/questions/24542/create-list-of-all-external-files-used-by-master-latex-document>
2. use `\listfiles`
3. use `lualatex -recorder foo.tex` it should create `foo.flx`

3.9 How to use minted

First install this

```
sudo apt-get install python-pygments
```

The above installed old version 1.6, so next I tried this

```
sudo pip install --upgrade pygments
```

Now the version is 2.1.3

Then call `pdflatex` like this

```
pdflatex --shell-escape foo.tex
```

Where `foo.tex` is

```
\documentclass[11pt]{article}%ext
\usepackage[T1]{fontenc}
\usepackage[utf8]{inputenc} %DO NOT USE WIT LUALATEX, only with pdflatex
\usepackage[tracking,protrusion=true,expansion=true]{microtype}
\usepackage[margin=1in]{geometry}

\usepackage{minted}
```

```
\usepackage{upquote} %to fix string quotes

\begin{document}
\begin{minted}[mathescape,linenos=true,fontfamily=tt,fontsize=\normalsize]
    {matlab}
clear all; close all;
t   = 0:0.05:50;
s   = tf('s');
sys = 1/(s^2+0.2*s+1);
y   = step(sys,t);
plot(t,y,'-r')
hold on
y   = impulse(sys,t);
plot(t,y,'-k')
title('Step and Impulse responses');
xlabel('t');
ylabel('y(t)');
xlim([0 50]);
ylim([-0.8 2]);
legend('step','impulse');
grid on;
set(gcf,'Position',[10,10,310,310]);
\end{minted}
\end{document}
```

To compile with tex4ht do this

```
htlatex foo.tex "" "" "" -shell-escape
```

To compile with make4ht do `make4ht foo.tex "--shell-escape"`

3.10 How to increase memory for Latex?

```
sudo vi /usr/local/texlive/2015/texmf.cnf
```

Added these:

```
% (Public domain.)
% This texmf.cnf file should contain only your personal changes from the
% original texmf.cnf (for example, as chosen in the installer).
%
```

```
% That is, if you need to make changes to texmf.cnf, put your custom
% settings in this file, which is ../texlive/YYYY/texmf.cnf, rather than
% the distributed file (which is ../texlive/YYYY/texmf-dist/web2c/texmf.cnf).
% And include *only* your changed values, not a copy of the whole thing!
%
buf_size=9000000
pool_size=9000000
main_memory=8000000
save_size=1000000
max_strings = 5000000
strings_free = 1000000
hash_extra=10000000
stack_size=500000
```

Then run

```
sudo -E env "PATH=$PATH" fmtutil-sys --all
```

3.11 How to use Maple style sheets (packages) with texlive?

I have `$HOME/texmf` and so did these steps

```
cd $HOME/texmf/tex/latex
mkdir maple
cd maple
cp C:\Program Files\Maple 18\etc\*.sty . %I use VBox

in other words

cp /maple_location/etc/*.sty . %copy all style files over
```

If using miktex, then use the GUI, add ROOT, and click apply.

3.12 How to install and use pdf2htmlEX?

To install

```
sudo apt-get update
sudo apt-get install pdf2htmlEX
```

To use

```
pdf2htmlEX --zoom 1.3 HW2_solution.pdf
```

To remove the side-bar which has extra TOC do

```
pdf2htmlEX --zoom 1.3 --embed-outline 0 foo.pdf
```

pdf2htmlEX seems to use html as extension. no option to change it so use this to make it use .htm which is what I use

```
pdf2htmlEX --zoom 1.3 --embed-outline 0 foo.pdf > foo.htm
```

One thing that I still do not understand about this program. It converts the whole pdf file to html page. Ok. But then what is the difference between this and using the build-in pdf reader in a browser, such as with Chrome for example?

I could not find how to make it split pages by sections and chapters and such as I can do with tex4ht. Without this ability, I am not sure how useful this will be for me. It is just like using the pdf itself this way. Will try to find out about this.

3.13 How to put image in a title page?

```
\documentclass[oneside,a4paper , 12 pt]{book}
\usepackage{titlepic}
\usepackage{graphicx}
\usepackage{caption}
%\usepackage{package}
%\usepackage[space]{grffile}

\begin{document}
\title{my book}
\author{me}
```

```
\date{\today}
\titlepic{
\begin{figure}[t!]
\centering
\includegraphics[width=0.7\linewidth]{img.png}
\caption{}
\label{fig:img}
\end{figure}
}
\maketitle

test

\end{document}
```

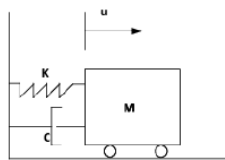

Figure 1

my book

me

February 27, 2014

3.14 How to convert pdf to eps?

See <http://tex.stackexchange.com/questions/20883/how-to-convert-pdf-to-eps> This `inkscape input.pdf --export-eps=output.eps` works ok, but the above command gives errors such as these on some images:

```
>inkscape 3d_1.pdf --export-eps=3d_1.eps
** Message: Invalid glyph found, continuing...
** Message: Invalid glyph found, continuing...
** Message: Invalid glyph found, continuing...
** Message: Invalid glyph found, continuing...
** Message: Invalid glyph found, continuing...
** Message: Invalid glyph found, continuing...
** Message: Invalid glyph found, continuing...
** Message: Invalid glyph found, continuing...
```

While on the same file, `pdf2eps` below works fine.

To crop pdf also (which can be useful) use this script by Herbert from above link

```
#!/bin/sh
# $Id: pdf2eps,v 0.01 2005/10/28 00:55:46 Herbert Voss Exp $
# Convert PDF to encapsulated PostScript.
# usage:
# pdf2eps <page number> <pdf file without ext>

pdfcrop $2.pdf
pdftops -f $1 -l $1 -eps "$2-crop.pdf"
rm "$2-crop.pdf"
mv "$2-crop.eps" $2.eps
```

I wrote the following simple script `prep` which process all the pdf image files and generates the needed files for `tex4ht`.

```
#!/bin/bash
for file in $1; do
    filename=${file%. *}
    pdf2svg "$filename.pdf" "$filename.svg"
    pdf2eps 1 "$filename"
done
```

It is called like this `prep "*.pdf"` or for one file `prep foo.pdf` it will generate a `.svg` and `.eps` for each file.

3.15 How to draw a baseline hairline for an equation?

This is thanks to @egreg from Tex stackexchange:

```
\newcommand{\rl}{\rlap{\vrule height 0pt depth .1pt width \textwidth}}
```

and then use `\rl` in the left hand sides of the equations.

3.16 How to find what changed in TeXLive?

see <http://tex.stackexchange.com/questions/156908/whats-new-on-tlmgr> one good method is by egreg which is this command <http://tug.org/svn/texlive/trunk/Master/texmf-dist/tex/latex/?sortBy=date>

3.17 extracting selected pages from a pdf?

To extract selected pages from a pdf into a separate pdf see <http://www.linuxjournal.com/content/tech-tip-extract-pages-pdf>

Use `pdftk` (free install on linux, use package manager). Here is an example

```
pdftk A=myfile.pdf cat A6-10 output result.pdf
```

3.18 how to include files in Latex

see <http://tex.stackexchange.com/questions/246/when-should-i-use-input-vs-include>

3.19 combining complete documents into one

3.19.1 combining using manual sectioning

Problem description: I have many standalone Latex documents that I want to compile into documents on their own, but also I want to combine them into one main document and have the table of contents and other references work as if all documents were written as one file.

Solution:

Given this example layout

```
home/main.tex
home/folderA/a.tex
```

Where main.tex and a.tex are self contained Latex files, each with its own title, table of contents and can include local resources such as images and listings.

Add the package `\usepackage{standalone}` in main.tex to strip all the preamble from the included latex files. Also add it to each child document, so that each child document can be compiled as standalone as well.

To use the above, make sure the master document at the top level includes all packages included by all the children.

Setup main.tex

```
\documentclass[12pt,notitlepage]{article}
\usepackage{standalone}%
\usepackage{listings}
\usepackage{import}
\usepackage{lipsum}
\usepackage{graphicx}
\usepackage{hyperref}

\makeatletter
\providecommand{\currentimportpath}{\import@path}
\makeatother

\begin{document}
\title{This is my document home/main.tex title}
\author{me}
```

```
\maketitle
\tableofcontents

\section{this is first section in main.tex}
once upon a time, and now include the other document

\subimport{folderA/}{a}
\end{document}
```

Setup a.tex as follows. This is important: remember to add `\standalone` after `\usepackage{standalone}` in each child package. We need this to be able to compile each child package on its own and get a table of contents and title. We will use an `\ifstandalone` logic in each child to check if we are building it standalone or not. When the main is build, this flag will automatically be false, hence we will not get table of content shown in each child. Little complicated, but just do it as shown:

```
\documentclass[12pt,notitlepage]{article}
\usepackage{standalone}
\standalonetrue    %remember this !

\usepackage{listings}
\usepackage{import}
\usepackage{lipsum}
\usepackage{graphicx}
\usepackage{hyperref}

\makeatletter
\providecommand{\currentimportpath}{\import@path}
\makeatother

\begin{document}

\ifstandalone    %Do this, so toc only shows when build standalone
  \title{This is my document home/folderA/a.tex title}
  \author{me}
  \maketitle
  \tableofcontents
\fi

\section{first section in file a.tex}
\includegraphics{a.png}
```

```
\section{second section in file a.tex}
\lstinputlisting{a.txt}

\section{third section in file a.tex}
you can find my report \href{\currentimportpath a.txt}{here}

\lipsum[1]
\end{document}
```

```

home/main.tex
\documentclass[12pt,notitlepage]{article}
\usepackage{standalone}%
\usepackage{listings}
\usepackage{import}
\usepackage{lipsum}
\usepackage{graphicx}
\usepackage{hyperref}

\makeatletter
\providecommand{\currentimportpath}{\import@path}
\makeatother

\begin{document}
\title{This is my document home/main.tex title}
\author{me}
\maketitle
\tableofcontents

\section{this is first section in main.tex}
once upon a time, and now include the other document

\subimport*{folderA/}{a}
\end{document}

```

This must be here, and in one document along the whole tree path being combined into one document

The main document, must have in its preamble the UNION of all packages included in all tex files being combined, even if one of these packages are not used in the main file. They have to be added here

Add any other latex file here. That latex file can be a complete latex document on its own

```

home/folderA/a.tex
\documentclass[12pt,notitlepage]{article}
\usepackage{standalone}
\standalonetrue %remember this !

\usepackage{listings}
\usepackage{import}
\usepackage{lipsum}
\usepackage{graphicx}
\usepackage{hyperref}

\makeatletter
\providecommand{\currentimportpath}{\import@path}
\makeatother

\begin{document}

\ifstandalone %Do this, so toc only shows when build standalone
\title{This is my document home/folderA/a.tex title}
\author{me}
\maketitle
\tableofcontents
\fi

\section{first section in file a.tex}
\includegraphics{a.png}

\section{second section in file a.tex}
\lstinputlisting{a.txt}

\section{third section in file a.tex}
you can find my report \href{\currentimportpath a.txt}{here}

\lipsum[1]
\end{document}

```



Notice: \currentimportpath followed by one space is needed for relative hrefs in all subfolder. However, \currentimportpath is not needed for \includegraphics and for \lstinput, even though these are also load relative objects. It is only \href that needs it.

Now you can compile a.texm or its own

```

cd home/folderA
pdflatex a.tex

```

And the result is

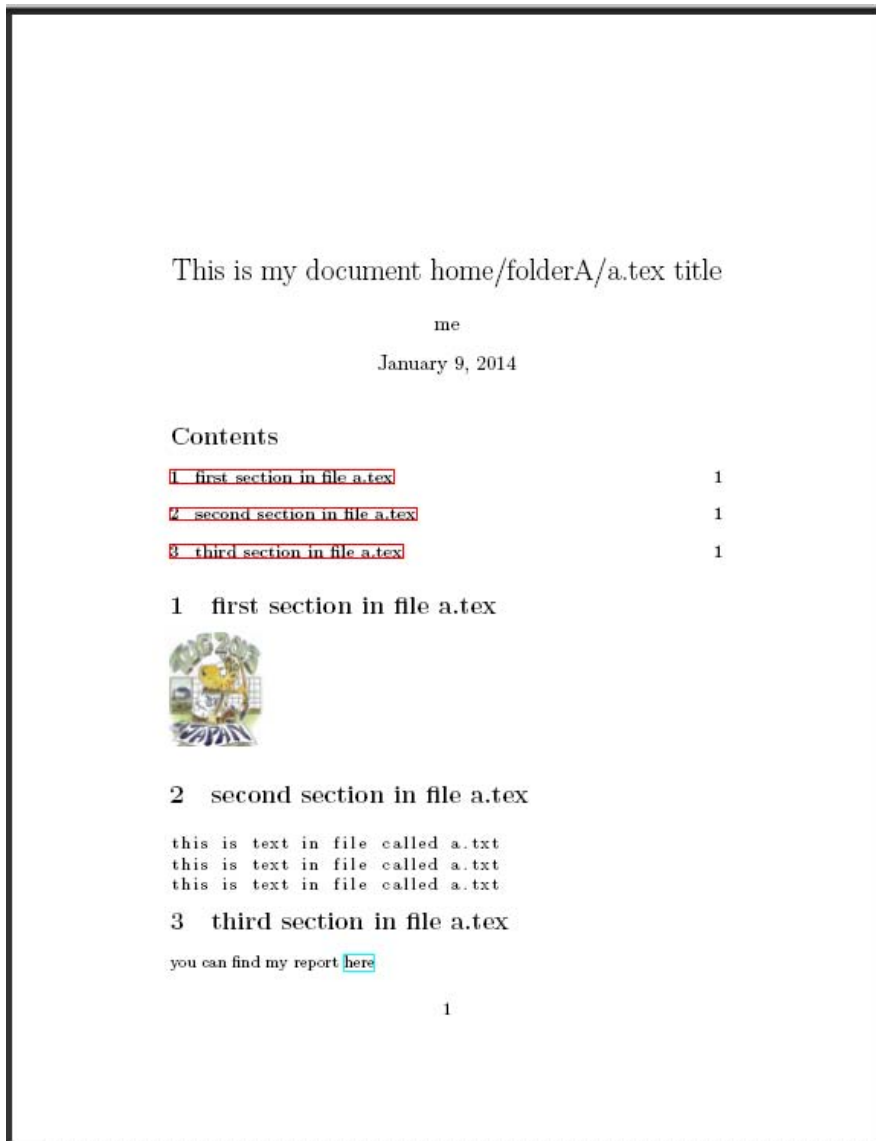

But when compiling `main.tex` `cd home; pdflatex main.tex` the result shows a table of contents that includes all children documents as shown

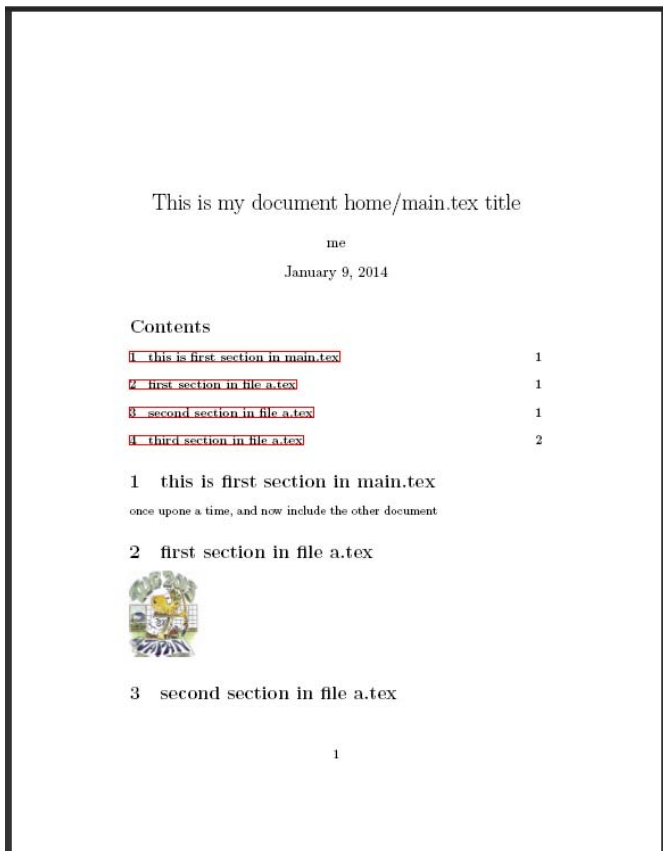

This is the result side by side

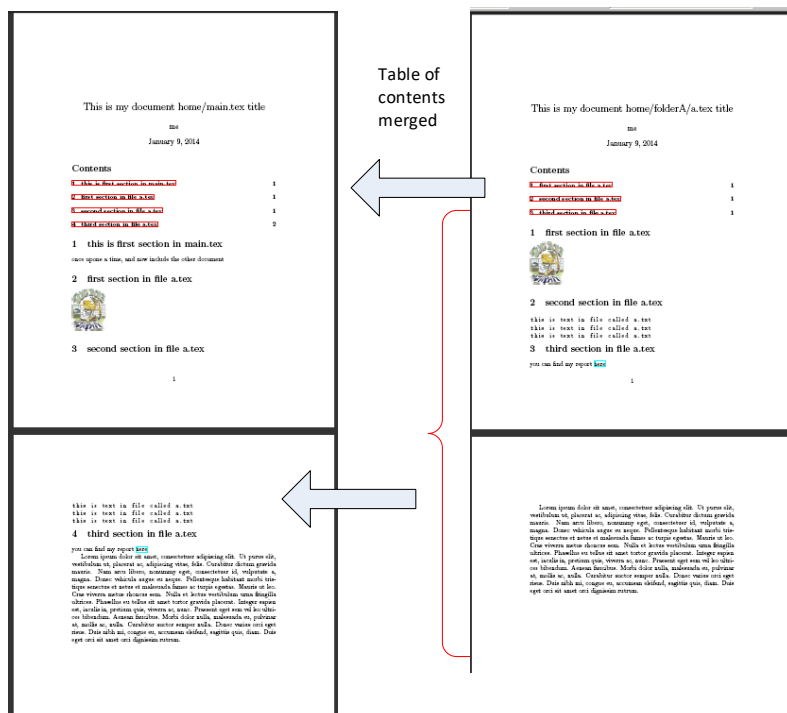

This zip file contains the tree shown above with all the files needed to rebuild it.

3.19.2 combining using automatic sectioning

One problem with the above approach, is that we had to be explicit with `\section` and `\subsection` in the correct order in different documents in different folders.

It would be better if this can be automated. Using a method shown here <http://tex.stackexchange.com/questions/9024/is-there-a-program-that-allows-to-move-sections-and-automatically-adjusts-the-le> and I modified it slightly, here are the files needed. First assume we have a tree like this:

```
home/main.tex
home/A/a.tex
home/A/B/b.tex
```

and we want to build `main.tex`, which includes `a.tex`, and where `a.tex` also includes `b.tex`, and where we can build each document as standalone. These are the 3 files

```
\documentclass[12pt,notitlepage]{book}
```

```
\usepackage{standalone}%
\input{commonlatex}

\begin{document}
\title{This is my document home/main.tex title}
\author{me}
\maketitle
\tableofcontents

\begin{deeplevel}{this is first section in main.tex}
once upon a time, and now include the other document

\subimport*{folderA/}{a}
\end{deeplevel}
\end{document}
```

the file a.tex is

```
\documentclass[12pt,notitlepage]{article}
\usepackage{standalone}
\standalonetrue
\input{commonlatex}

\begin{document}

\ifstandalone
  \setcounter{level@depth}{1}
  \title{This is my document home/folderA/a.tex title}
  \author{me}
  \maketitle
  \tableofcontents
\fi

\begin{deeplevel}{first section in file a.tex}
\includegraphics{a.png}

  \subimport*{folderAB/}{b}

  \begin{deeplevel}{this should show up below the above}
    \lipsum[75]
  \end{deeplevel}
\end{deeplevel}
```



```
\end{deeplevel}

\begin{deeplevel}{second section in file a.tex}
\lstinputlisting{a.txt}
\end{deeplevel}

\begin{deeplevel}{third section in file a.tex}
you can find my report \href{\currentimportpath a.txt}{here}
\end{deeplevel}

\lipsum[1]
\end{document}
```

and the file b.tex is

```
\documentclass[12pt,notitlepage]{article}
\usepackage{standalone}
\standalonetrue
\input{commonlatex}

\begin{document}

\ifstandalone
  \setcounter{level@depth}{2}
  \title{This is my document home/folderA/folderB/b.tex title}
  \author{me}
  \maketitle
  \tableofcontents
\fi

\begin{deeplevel}{first section in file b.tex}
\lipsum[75]

\begin{deeplevel}{this should show up below the above}
  \lipsum[75]
\end{deeplevel}

\end{deeplevel}

\begin{deeplevel}{second section in file b.tex}
```

```

\lstinputlisting{b.txt}
\end{deeplevel}

\begin{deeplevel}{third section in file b.tex}
you can find my report \href{\currentimportpath b.txt}{here}
\end{deeplevel}

\lipsum[1]
\end{document}

```

and the common include file is

```

%=====
\makeatletter
\newcounter{level@depth}
\setcounter{level@depth}{-1}

\newenvironment{deeplevel} %
{ %
  \addtocounter{level@depth}{1}%

  \ifcase\c@level@depth
  \expandafter \part
  \or \expandafter \chapter
  \or \expandafter \section
  \or \expandafter \subsection
  \or \expandafter \subsubsection
  \or \expandafter \paragraph
  \or \expandafter \subparagraph
  \or \expandafter \subsubparagraph
  \else
  \PackageError{deeplevel}
  { %
    Sections are too deeply nested.%
  } %
  { %
    Trying to recover with \string\subsubparagraph%
  } %
  \expandafter \subsubparagraph
\fi

```

```
} %  
{%  
  \addtocounter{level@depth}{-1}%  
}  
  
\makeatother
```

Now one is able to build main.tex or a.tex or b.tex each on its own, and still get a complete document for each.

3.20 how to install lyx on Linux

see <http://wiki.lyx.org/LyX/LyXOnUbuntu>

if not in the package manager PPA, then do

```
sudo add-apt-repository ppa:lyx-devel/daily (add the PPA)  
sudo apt-get update (update so that apt is aware of the new PPA)  
sudo apt-get install lyx2.0 (install from the PPA)  
lyx2.0 &
```

3.21 using hyperlinks

<http://biosun1.harvard.edu/~paciorek>

More info on pdf hyper-references is at <http://www.tug.org/applications/hyperreff/manual.html>.

3.22 page breaks

reference: <http://help-csli.stanford.edu/tex/latex-pagebreaks.shtml>

```
\pagebreak[]  
use to start a new page at the end of the current line. Without  
arguments it forces a page break. With arguments of 0,1,2,3,  
or 4 it suggests that this is a good place to break. 4 being  
equivalent to no argument and forcing the break. No extra space  
is put at the end of the page.
```

```
\nopagebreak
  similar to \pagebreak except it prevents a pagebreak at the end
  of the current line. I rarely use it.
\samepage
  pretty much as the latex manual says. I rarely use it.
\newpage
  forces a break at the point and puts in space as needed at the
  end of the page.
\clearpage
  similar to \newpage but figures are also printed
\cleardoublepage
  similar to \clearpage but will force another page if needed so
  the next page with print is odd numbered.
```

3.23 using tables

From <http://www.andy-roberts.net/writing/latex/tables>

The `tabular` is another such environment, designed for formatting your data into nicely arranged tables. Arguments are required after the environment declaration to describe the alignment of each column. The number of columns does not need to be specified as it is inferred by looking at the number of arguments provided. It is also possible to add vertical lines between the columns here.

The following symbols are available to describe the table columns:

```
l      left-justified column
c      centered column
r      right-justified column
p{width}    paragraph column with text vertically aligned at the top
m{width}    paragraph column with text vertically aligned in the middle
b{width}    paragraph column with text vertically aligned at the bottom
|      vertical line
||     double vertical line
```

```
Once in the environment,
&      column separator
\\     start new row
\hline horizontal line
```

to adjust the spacing between rows in a latex table, add square brackets and the size adjustment after the linebreak.

for instance, to compress rows by 1 inch:

```
entry1 & entry2 & entry3 \\[-1in]
```

3.24 passing flag from command line to pdflatex and htlatex?

for htlatex

```
htlatex main.tex "" "" "" "\def\flag{}
```

for pdflatex

```
pdflatex "\def\flag{\input{main.tex}}"
```

and now inside main.tex write

```
\documentclass{article}
\begin{document}
\ifdefined\flag
  yes
\else
  no
\fi
\end{document}
```

3.25 What levels are there? TOC configuration

from http://www.emerson.emory.edu/services/latex/latex_132.html

Sectioning commands provide the means to structure your text into units.

```
\part
\chapter (report style only)
\section
```

```

\subsection
\subsubsection
\paragraph
\subparagraph
\subsubparagraph (milstd and book-form styles only)
\subsubsubparagraph (milstd and book-form styles only)

```

```

\part -1 -----> school
\chapter 0 -----> semester
\section 1 -----> course
\subsection 2 -----> HWs
\subsubsection 3 -----> HW1,2,3....
\paragraph 4 -----> part(a),(b),.....
\subparagraph 5

```

3.26 TOC related

`\setcounter{tocdepth}{n}` where `n` is an integer, tells latex how deep to make TOC. `n` depends on the class type, see above.

`\setcounter{secnumdepth}{m}` tells latex which entries in the TOC (which depends on the first command above) to give it a number to the left side. default is 3 I think. But better to have numbers for all sections and subsection in TOC.

Do the above in preamble of document.

some links on TOC in latex

1. <http://www.andy-roberts.net/writing/latex/contents>
2. <http://help-csli.stanford.edu/tex/latex-sections.shtml>
3. <http://facweb.knowlton.ohio-state.edu/pvixon/support/swphtpa4.html>
4. To make paragraph make new entry in TOC below subsubsection, see this

can change depth of toc using `\setcounter{tocdepth}{depth}` in preamble. it looks like default depth is 3.

3.27 on fonts

using Fourier fonts

```
\usepackage{fourier}
\usepackage[T1]{fontenc}
```

may be need to install. I got error

```
! LaTeX Error: File `fourier.sty' not found.
```

remember the `$ texhash` command also.

try downloading it from <http://www.ctan.org/pkg/fourier> but I'll wait until Tex Live 2013 is out. There are more steps to do to install it it seems.

3.28 pixels and Latex

From David Carlisle

```
40px is a variable size depending on screen resolution,
if you take a nominal 76 dpi then it's 40/76 on 1in.
```

3.29 on equations

Need to work on this.

3.29.1 using align with references

see <http://www.dickimaw-books.com>

This image below from the above page <http://www.dickimaw-books.com/latex/novices/html/align.html>

Example (Cross-Referenced):

This example has two numbered equations in an `align` environment, both of which are labelled and referenced:

```
The function  $f(x)$  is given in Equation~\eqref{eq:fx}, and its derivative  $f'(x)$  is given in
Equation~\eqref{eq:dfx}.
\begin{align}
f(x) &= 2x + 1 \label{eq:fx} \\
f'(x) &= 2 \label{eq:dfx}
\end{align}
```

The function $f(x)$ is given in Equation (9.4), and its derivative $f'(x)$ is given in Equation (9.5).

$$f(x) = 2x + 1 \tag{9.4}$$

$$f'(x) = 2 \tag{9.5}$$

3.30 How to upgrade latex once installed?

see <http://tex.stackexchange.com/questions/55437/how-do-i-update-my-tex-distribution>

Basically, just do

```
sudo /usr/local/texlive/2014/bin/i386-linux/tlmgr update --self
sudo /usr/local/texlive/2014/bin/i386-linux/tlmgr update --all
```

For TL 2015

```
sudo /usr/local/texlive/2015/bin/x86_64-linux/tlmgr update --self
sudo /usr/local/texlive/2015/bin/x86_64-linux/tlmgr update --all
```

3.31 Things to do post Installation of texlive 2016 on Linux

These are the steps I need to do after installation of TL

1. fix `\pgfusepathqfill` bug. See <http://tex.stackexchange.com/questions/185349/error-using-pgfsysdriver-with-tex4ht-only-shows-up-with-texlive-2014-ok-with-t>
2. There is a new error when compiling `make4ht --lua` see <http://tex.stackexchange.com/questions/315162/error-with-tex4ht-under-tl-2016-when-u>

`sing-lua-string-contains-an-invalid-utf-8` but this should be fixed very soon (ok, already fixed)

3. If compiling with `lualatex`, need to add this to all files

```
\IfFileExists{luatex85.sty}
{
\usepackage{luatex85}
}
{}
```

4. Watch out, do not use `\usepackage[T1]{fontenc}` Makes `tex4ht` `\verb` not accept different fonts. Bug. see <http://tex.stackexchange.com/questions/318232/why-tex4ht-do-not-change-font-size-of-verb-when-including-usepackaget1font>
5. Increase `bufsize`, else it will fail on some large builds

```
sudo vi /usr/local/texlive/2016/texmf.cnf
```

Added these:

```
% (Public domain.)
% This texmf.cnf file should contain only your personal changes from the
% original texmf.cnf (for example, as chosen in the installer).
%
% That is, if you need to make changes to texmf.cnf, put your custom
% settings in this file, which is ../texlive/YYYY/texmf.cnf, rather than
% the distributed file (which is ../texlive/YYYY/texmf-dist/web2c/texmf.cnf).
% And include only your changed values, not a copy of the whole thing!
%

buf_size=90000000
pool_size=90000000
main_memory=80000000
save_size=10000000
```

6. increase open file limit, `lualatex` still has problem

edit the file `/etc/security/limits.conf` as root and add these lines

```
* soft nofile 4096
* hard nofile 4096
```

7. install pdf2svg `sudo apt-get install pdf2svg`
8. install scour (do not use `apt-get install scour`, use pip to get latest version)

```

sudo apt-get install python-pip
sudo pip install scour

Downloading/unpacking scour
  Downloading scour-0.33.tar.gz
  Running setup.py (path:/tmp/pip_build_root/scour/setup.py) egg_info for package scour

Downloading/unpacking six>=1.9.0 (from scour)
  Downloading six-1.10.0-py2.py3-none-any.whl
Installing collected packages: scour, six
  Running setup.py install for scour

  Installing scour script to /usr/local/bin
  Found existing installation: six 1.5.2
  Not uninstalling six at /usr/lib/python2.7/dist-packages, owned by OS
Successfully installed scour six
Cleaning up...

>which scour
/usr/local/bin/scour

>scour --version
0.33

```

used to shrink size of svg images (clean them)

9. fix `algorithm2e.sty` so that `lualatex` can use

```

styles>kpsewhich algorithm2e.sty
/usr/local/texlive/2016/texmf-dist/tex/latex/algorithm2e/algorithm2e.sty

```

and remove 2 lines with non-ascii chars, around lines 1313 and 1315.

10. Make sure not to use `subimport*` but use `\subimport`
11. install `sudo apt-get install imagemagick` for `convert` command

12. `install sudo apt-get install optipng` to optimize png

3.32 Installation of texlive 2015 on Linux

Download the .gz file from <https://www.tug.org/texlive/acquire-netinstall.html>

```
install-tl-unx.tar.gz
```

Then extract

```
gunzip install-tl-unx.tar.gz
tar -xvf install-tl-unx.tar
```

Then move to the folder created from the above and do

```
sudo ./install-tl
```

Make sure to change the paper type to letter. The default is A4.

```
=====> TeX Live installation procedure <=====
=====> Letters/digits in <angle brackets> indicate <=====
=====> menu items for commands or options <=====

Detected platform: GNU/Linux on Intel x86

<B> binary platforms: 1 out of 19

<S> set installation scheme (scheme-full)

<C> customizing installation collections
    47 collections out of 48, disk space required: 4061 MB

<D> directories:
    TEXDIR (the main TeX directory):
        /usr/local/texlive/2015
    TEXMFLOCAL (directory for site-wide local files):
        /usr/local/texlive/texmf-local
    TEXMFSYSVAR (directory for variable and automatically generated data):
        /usr/local/texlive/2015/texmf-var
```

```
TEXMFSYSCONFIG (directory for local config):
  /usr/local/texlive/2015/texmf-config
TEXMFVAR (personal directory for variable and automatically generated data):
  ~/.texlive2015/texmf-var
TEXMFCONFIG (personal directory for local config):
  ~/.texlive2015/texmf-config
TEXMFHOME (directory for user-specific files):
  ~/texmf
```

<O> options:

```
[ ] use letter size instead of A4 by default
[X] allow execution of restricted list of programs via \write18
[X] create all format files
[X] install macro/font doc tree
[X] install macro/font source tree
[ ] create symlinks to standard directories
```

<V> set up for portable installation

Actions:

```
<I> start installation to hard disk
<H> help
<Q> quit
```

Enter O and then

Options setup:

```
<P> use letter size instead of A4 by default: [X]
<E> execution of restricted list of programs: [X]
<F> create format files: [X]
<D> install font/macro doc tree: [X]
<S> install font/macro source tree: [X]
<L> create symlinks in standard directories: [ ]
      binaries to:
      manpages to:
      info to:
```

Actions: (disk space required: 4061 MB)

```
<R> return to main menu
<Q> quit
```

```
Enter command: R
```

I do not know what `create symlinks` in standard directories is supposed to be set to so leave it blank and add path in your `.bashrc` to the latex bin folder

```
Enter command: I
Installing to: /usr/local/texlive/2015
Installing [0001/3068, time/total: ??:??/?:?]: 12many [376k]
Installing [0002/3068, time/total: 00:07/09:58:59]: 2up [66k]
Installing [0003/3068, time/total: 00:08/09:43:10]: Asana-Math [482k]
Installing [0004/3068, time/total: 00:17/09:51:45]: ESIEEcvt [137k]
Installing [0005/3068, time/total: 00:20/10:06:31]: FAQ-en [4971k]
Installing [0006/3068, time/total: 01:55/10:12:15]: GS1 [1100k]
Installing [0007/3068, time/total: 02:15/10:07:53]: HA-prosper [266k]
Installing [0008/3068, time/total: 02:20/10:07:44]: IEEEconf [188k]
Installing [0009/3068, time/total: 02:24/10:09:36]: IEEEtran [1355k]
Installing [0010/3068, time/total: 02:49/10:07:00]: MemoirChapStyles [739k]
Installing [0011/3068, time/total: 03:03/10:07:07]: SIstyle [338k]
Installing [0012/3068, time/total: 03:10/10:09:07]: SIunits [284k]
Installing [0013/3068, time/total: 03:15/10:07:54]: Tabbings [217k]
Installing [0014/3068, time/total: 03:20/10:10:39]: Type1fonts [516k]
Installing [0015/3068, time/total: 03:30/10:11:13]: a0poster [119k]
Installing [0016/3068, time/total: 03:32/10:10:28]: a2ping [48k]
Installing [0017/3068, time/total: 03:33/10:10:45]: a2ping.i386-linux [1k]
Installing [0018/3068, time/total: 03:33/10:10:44]: a4wide [133k]
Installing [0019/3068, time/total: 03:35/10:09:15]: a5comb [91k]
Installing [0020/3068, time/total: 03:37/10:10:03]: aastex [1292k]
Installing [0021/3068, time/total: 04:05/10:18:46]: abbr [4k]
Installing [0022/3068, time/total: 04:05/10:18:36]: abc [156k]
Installing [0023/3068, time/total: 04:09/10:21:06]: abntex2 [4493k]
.....
running fmtutil-sys --no-error-if-no-engine=luajitte --all ...done
running package-specific postactions
finished with package-specific postactions

See
  /usr/local/texlive/2015/index.html
for links to documentation. The TeX Live web site
contains updates and corrections: http://tug.org/texlive.
```

```
TeX Live is a joint project of the TeX user groups around the world;
please consider supporting it by joining the group best for you. The
list of user groups is on the web at http://tug.org/usergroups.html.
```

```
Add /usr/local/texlive/2015/texmf-dist/doc/info to INFOPATH.
Add /usr/local/texlive/2015/texmf-dist/doc/man to MANPATH
    (if not dynamically found).
```

```
Most importantly, add /usr/local/texlive/2015/bin/i386-linux
to your PATH for current and future sessions.
```

```
Welcome to TeX Live!
```

```
Logfile: /usr/local/texlive/2015/install-tl.log
```

```
>
```

Now install make4ht. Make sure it goes to `~/texmf/scripts/luamake4ht` and to set the path to point to the above as well.

No need to install lua as it comes with TL

Make sure to fix the pgsysdriver to be able to use tikz, see this

3.33 Installation of texlive 2014 on Linux

Download the .gz file from <http://ctan.math.washington.edu/tex-archive/systems/texlive/tlnet/>

```
install-tl-unx.tar.gz 16-Jun-2014 18:26 3.2M
```

Then extract

```
gunzip install-tl-unx.tar.gz
tar -xvf install-tl-unx.tar
```

Then move to the folder created from the above and do

```

sudo ./install-tl

Make sure to change the paper type to letter. The default is
A4.

Enter command: I
Installing to: /usr/local/texlive/2014
....
TeX Live is a joint project of the TeX user groups around the world;
please consider supporting it by joining the group best for you. The
list of user groups is on the web at http://tug.org/usergroups.html.

Add /usr/local/texlive/2014/texmf-dist/doc/info to INFOPATH.
Add /usr/local/texlive/2014/texmf-dist/doc/man to MANPATH
(if not dynamically found).

Most importantly, add /usr/local/texlive/2014/bin/i386-linux
to your PATH for current and future sessions.

Welcome to TeX Live!

Summary of warning messages during installation:
  Partial download of http://mirror.jmu.edu/pub/CTAN/systems/texlive/tlnet/archive/chletter.doc.ta

Logfile: /usr/local/texlive/2014/install-tl.log
>

```

3.33.1 post installation for tex4ht issues

I need to fix/add few things after texlive is installed for tex4ht. This is a summary of the items to do.

1. When using standalone package, this error will show up with tex4ht only

```

(/usr/local/texlive/2014/texmf-dist/tex/generic/xkeyval/xkeyval.tex
(/usr/local/texlive/2014/texmf-dist/tex/generic/xkeyval/keyval.tex))
! Extra \else.
1.227      \else

? x

```

There is a patch for this. Get the updated `standalone.sty` and replace the

current installed one with it. The standalong.sty can be found at https://bitbucket.org/martin_scharrer/standalone/raw/635aacfa0e8f2cba4f4086f4f15d57791b18bf64/standalone.sty

Replace the file `/usr/local/texlive/2013/texmf-dist/tex/latex/standalone/standalone` With it. Now this problem will go away.

2. Install `make4ht`
3. fix `tex4ht.env` file to improve the fonts generated when making images for math. see elsewhere here for instructions. This step is not needed any more, since I switched to `make4ht` for compiling, since `make4ht` does not use `tex4ht.env`, but if you are not using `make4ht`, then `tex4ht.env` is still used by standard `hlatex` command.

3.34 installation of T_EX Live 2013

This is the log from

download <http://mirror.ctan.org/systems/texlive/tlnet/install-tl-unx.tar.gz>

```
>ls -l
total 0
drwxrwxrwx 1 me me 0 Jan 16 18:34 install-tl-20140116
>cd install-tl-20140116/
>ls -l
total 89
-rwxrwxrwx 1 me me 1157 May 31 2010 index.html
-rwxrwxrwx 1 me me 79388 Sep 15 15:16 install-tl
-rwxrwxrwx 1 me me 2098 Sep 28 2006 LICENSE.CTAN
-rwxrwxrwx 1 me me 5086 Jun 5 2011 LICENSE.TL
-rwxrwxrwx 1 me me 183 Aug 9 2008 README
drwxrwxrwx 1 me me 0 Jan 16 18:34 readme-html.dir
drwxrwxrwx 1 me me 0 Jan 16 18:34 readme-txt.dir
-rwxrwxrwx 1 me me 250 Aug 9 2008 README.usergroups
-rwxrwxrwx 1 me me 360 May 29 2013 release-texlive.txt
drwxrwxrwx 1 me me 0 Jan 16 18:34 texmf-dist
drwxrwxrwx 1 me me 0 Jan 16 18:34 tlpkg
>
```

now run the installer as root `sudo ./install-tl`

```
[sudo] password for me:
Loading http://mirrors.rit.edu/CTAN/systems/texlive/tlnet/tlpkg/texlive.tlpdb
Installing TeX Live 2013 from: http://mirrors.rit.edu/CTAN/systems/texlive/tlnet
Platform: i386-linux => 'Intel x86 with GNU/Linux'
Distribution: net (downloading)
Using URL: http://mirrors.rit.edu/CTAN/systems/texlive/tlnet
Directory for temporary files: /tmp

=====> TeX Live installation procedure <=====

=====> Letters/digits in <angle brackets> indicate <=====
=====> menu items for commands or options <=====

Detected platform: Intel x86 with GNU/Linux

<B> binary platforms: 1 out of 21

<S> set installation scheme (scheme-full)

<C> customizing installation collections
    44 collections out of 45, disk space required: 3533 MB

<D> directories:
    TEXDIR (the main TeX directory):
        /usr/local/texlive/2013
    TEXMFLOCAL (directory for site-wide local files):
        /usr/local/texlive/texmf-local
    TEXMFSYSVAR (directory for variable and automatically generated data):
        /usr/local/texlive/2013/texmf-var
    TEXMFSYSCONFIG (directory for local config):
        /usr/local/texlive/2013/texmf-config
    TEXMFVAR (personal directory for variable and automatically generated data):
        ~/.texlive2013/texmf-var
    TEXMFCONFIG (personal directory for local config):
        ~/.texlive2013/texmf-config
    TEXMFHOME (directory for user-specific files):
        ~/texmf

<O> options:
    [ ] use letter size instead of A4 by default
    [X] allow execution of restricted list of programs via \write18
```

```
[X] create all format files
[X] install macro/font doc tree
[X] install macro/font source tree

<V> set up for portable installation

Actions:
<I> start installation to hard disk
<H> help
<Q> quit

Enter command: I

Installing to: /usr/local/texlive/2013
Installing [0001/2785, time/total: ??:??/?:?]: 12many [376k]
Installing [0002/2785, time/total: 00:01/01:16:21]: 2up [66k]
Installing [0003/2785, time/total: 00:02/02:10:06]: Asana-Math [458]
.....
  go make coffee now and come back in 1 hr or so..
.....
system      | lua | dumping '/usr/local/texlive/2013/texmf-var/luatex-cache/context/a86c
resolvers   | caching | 'files' compiled to '/usr/local/texlive/2013/texmf-var/luatex-ca
mtxrun      |
mtxrun      | runtime: 2.546 seconds
done
pre-generating all format files (fmtutil-sys --all), be patient...done
running package-specific postactions
finished with package-specific postactions

See
  /usr/local/texlive/2013/index.html
for links to documentation. The TeX Live web site
contains updates and corrections: http://tug.org/texlive.

TeX Live is a joint project of the TeX user groups around the world;
please consider supporting it by joining the group best for you. The
list of user groups is on the web at http://tug.org/usergroups.html.

Add /usr/local/texlive/2013/texmf-dist/doc/info to INFOPATH.
Add /usr/local/texlive/2013/texmf-dist/doc/man to MANPATH
```

(if not dynamically found).

Most importantly, add `/usr/local/texlive/2013/bin/i386-linux` to your PATH for current and future sessions.

Welcome to TeX Live!

Logfile: `/usr/local/texlive/2013/install-tl.log`

>

Here is the logfile `install-tl.log.txt`

To update do

```

sudo 'which tlmgr' update --self --all --reinstall-forcibly-removed

[sudo] password for me:

tlmgr: package repository http://ctan.mirrors.hoobly.com/systems/texlive/tlnet
tlmgr: saving backups to /usr/local/texlive/2013/tlpkg/backups
[1/1, ??:??/?:??] update: texlive.infra [299k] (31401 -> 31673) ... done
Restarting tlmgr to complete update ...
tlmgr: package repository http://ctan.mirrors.hoobly.com/systems/texlive/tlnet
tlmgr: saving backups to /usr/local/texlive/2013/tlpkg/backups
[ 1/293] auto-remove: lgrx ... done
[ 2/293] auto-remove: gmeometric ... done
[ 3/293, ??:??/?:??] update: Asana-Math [458k] (27228 -> 31750) ... done
[ 4/293, 00:05/55:11] update: abntex2 [4526k] (31530 -> 32490) ... done
[ 5/293, 00:10/10:08] update: achemso [469k] (31608 -> 31893) ... done
[ 6/293, 00:12/11:07] update: acro [532k] (31571 -> 32450) ... done
[ 7/293, 00:20/16:53] update: amiri [1637k] (30816 -> 32506) ... done
[ 8/293, 00:25/16:34] update: animate [3085k] (31241 -> 31766) ... done
[ 9/293, 00:28/13:12] update: autonum [379k] (30979 -> 32126) ... done
.....
[289/293, 15:22/15:22] update: collection-plainextra [1k] (30395 -> 31683) ... done
[290/293, 15:23/15:23] update: collection-pstricks [1k] (31016 -> 32514) ... done
[291/293, 15:24/15:24] update: collection-publishers [1k] (31532 -> 32440) ... done
[292/293, 15:24/15:24] update: collection-science [1k] (30307 -> 32182) ... done
[293/293, 15:25/15:25] update: scheme-context [1k] (29997 -> 32062) ... done
tlmgr: package log updated: /usr/local/texlive/2013/texmf-var/web2c/tlmgr.log
running mktexlsr ...
done running mktexlsr.
running mtxrun --generate ...
done running mtxrun --generate.
running updmap-sys ...
done running updmap-sys.
regenerating fmtutil.cnf in /usr/local/texlive/2013/texmf-var
running fmtutil-sys --no-error-if-no-format --byengine ptex ...
done running fmtutil-sys --no-error-if-no-format --byengine ptex.
running fmtutil-sys --no-error-if-no-format --byengine eptex ...
done running fmtutil-sys --no-error-if-no-format --byengine eptex.
running fmtutil-sys --no-error-if-no-format --byengine pdftex ...
done running fmtutil-sys --no-error-if-no-format --byengine pdftex.
running fmtutil-sys --byfmt cont-en ...
done running fmtutil-sys --byfmt cont-en.
running fmtutil-sys --byfmt pdfcsplain ...
done running fmtutil-sys --byfmt pdfcsplain.
>

```

The `/usr/local/texlive/2013/texmf-var/web2c/tlmgr.log` log file contains the full listing. It appends the log of each update to the last update. so the log will contain all the updates done and not just the one just done

```
[Fri Jun 21 01:03:25 2013] update: dvipdfmx.i386-linux (30205 -> 30845)
[Fri Jun 21 01:03:28 2013] update: dvipng.i386-linux (30088 -> 30845)
[Fri Jun 21 01:03:50 2013] update: luatex.i386-linux (30739 -> 30845)
.....
[Tue Jan 7 17:39:02 2014] update: collection-latexextra (31599 -> 32457)
[Tue Jan 7 17:39:03 2014] update: collection-metapost (30387 -> 32455)
[Tue Jan 7 17:39:04 2014] update: collection-music (31524 -> 32405)
[Tue Jan 7 17:39:04 2014] update: collection-pictures (31517 -> 32320)
[Tue Jan 7 17:39:05 2014] update: collection-plainextra (30395 -> 31683)
[Tue Jan 7 17:39:06 2014] update: collection-pstricks (31016 -> 32514)
[Tue Jan 7 17:39:06 2014] update: collection-publishers (31532 -> 32440)
[Tue Jan 7 17:39:07 2014] update: collection-science (30307 -> 32182)
[Tue Jan 7 17:39:08 2014] update: scheme-context (29997 -> 32062)
```

To start the tlmgr GUI, must be root, and the command is

```
sudo `which tlmgr` gui
```

got T_EX Live DVD today. Here is the front and the back

3.35 on using multicol

1. to force a figure in a column, let includegraphics resize it using `\includegraphics[width=\columnwidth]`

3.36 How to place figures

Using `\begin{figure}` makes images float and so hard to control the location. Instead, can use just `\includegraphics{name}` but to get use caption, use this method by Gonzalo Medina

When this viewed in HTML, tex4ht puts one image below the other. It seems tex4ht does not support minipages.

To do the same for tex4ht try the following, using multicol's new support added to tex4ht

```

\documentclass{article}
\usepackage[demo]{graphicx}
\usepackage{capt-of}
\usepackage{lipsum}%

\begin{document}
\lipsum[1]
\begin{center}
\includegraphics{foo}
\captionof{figure}{A non floating figure}
\label{fig:test}
\end{center}

\lipsum[2]
\end{document}
    
```

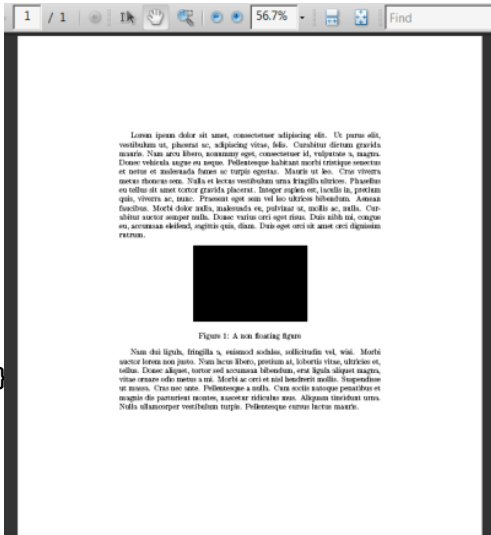

Figure 3.1: result of the above

These are different examples of placing figures

```

\documentclass{article}
\usepackage{subfigure}
\usepackage{lipsum}
\usepackage[demo]{graphicx}
\usepackage[utf8]{inputenc}

\begin{document}
\lipsum[1]

\begin{figure}[ht!]
\begin{center}
%
\subfigure[Caption of First Figure]{%
\label{fig:first}
\includegraphics[width=0.4\textwidth]{FirstFigure}
}%
\subfigure[Caption of Second Figure]{%
\label{fig:second}
\includegraphics[width=0.4\textwidth]{SecondFigure}
}%
}\ \ % ----- End of the first row ----- %
\subfigure[Caption of Third Figure]{%
\label{fig:third}
    
```

```

        \includegraphics[width=0.4\textwidth]{ThirdFigure}
    }%
    \subfigure[Caption of Fourth Figure]{%
        \label{fig:fourth}
        \includegraphics[width=0.4\textwidth]{FourthFigure}
    }%
%
\end{center}
\caption{%
    The l-o-n-g caption for all the subfigures
    (FirstFigure through FourthFigure) goes here.
}%
\label{fig:subfigures}
\end{figure}

\lipsum[2-5]
\end{document}

```

references:

1. <http://tex.stackexchange.com/questions/107363/putting-multiple-images-in-a-page>

3.37 Finding definitions of LaTeX control sequences?

use `texdef -t latex <control word>`

For example

```

>texdef -t latex input

\input:
macro:->\@ifnextchar \bgroup \@iinput \@@input

>
>texdef -t latex pi

\pi:
\mathchar"119

```

```
\the\pi:
281

>texdef -t latex frac

\frac:
macro:#1#2->{\begingroup #1\endgroup \over #2}
```

3.38 wrapping text around figures

see <http://tex.stackexchange.com/questions/56176/handling-of-wrapfig-pictures-in-latex> and <http://texblog.org/tag/wrapfigure/> also there is wrappable see <http://tex.stackexchange.com/questions/49300/wrap-text-around-a-tabular>

From the first link:

```
\documentclass{article}
\usepackage{wrapfig}
\usepackage{lipsum}

\begin{document}

\lipsum[1-4]
\begin{wrapfigure}{R}{5cm}
\centering
\rule{3cm}{7cm}
\end{wrapfigure}
\lipsum[1-6]

\end{document}
```

3.39 what tex editors to use?

list of some I tried

1. Texmaker (shows structure of document on left panel. Ok, but it gets confused with `\Verbatim` that has also Latex code in it, it think it is part of the document and shows it in the structure of the actual document as well.
2. texworks
3. Kyle on Linux (nice)

3.40 How to define text block to use in more than one place?

Thanks for TorbjørnT. from Tex forum for these methods.

Sometimes I needed to define some text and put it in 2 different places.

If the text has no verbatim in it, this method can be used

```
\documentclass{article}%
\begin{document}

\newcommand\mytext{
text with some with no verbatim

more text here
}

\mytext

\renewcommand\mytext{
more text with here

more text here also.....
}

\mytext

\end{document}
```

But if the text has verbatim in it, the above does not work. Use this method

```
\documentclass{article}%
\usepackage{filecontents}
\begin{document}

\begin{filecontents*}{somefile.txt}
Text with \verb|Initialization| verbatim it.

This would now be put in text file, then read again
\end{filecontents*}

\input{somefile.txt}
\end{document}
```

3.41 adjusting text, parskip, parindent

From <http://www.andy-roberts.net/writing/latex/tables>

There are also things known as command lengths, which are not fixed values as they depend on the configuration of the current document class and/or preamble. Useful ones include:

- * `\parindent` - the size of the paragraph indent
- * `\baselineskip` - vertical distance between lines.
- * `\parskip` - the extra space between paragraphs.
- * `\textwidth` - the width of a line of text in the local environment (e.g., the lines are commonly narrower in the abstract than in the normal text).
- * `\textheight` - the height of the text on the page.

try this sometime

```
%
% this makes list spacing much better.
%
\newenvironment{my_enumerate}{
\begin{enumerate}
```

```

\setlength{\itemsep}{1pt}
\setlength{\parskip}{0pt}
\setlength{\parsep}{0pt}}{\end{enumerate}
}

```

What I do is insert this code somewhere at the top of my LaTeX document, before I need to create any enumerations. Then, later in the document, when I do want to create an enumeration, instead of using the `enumerate` tag, I use the `my_enumerate`

3.42 How to reduce size of math in one place only?

```

\text{\scriptsize $\sin(x)$}

```

Use different size as needed, `footnotesize` or `tiny` and others.

3.43 How to hand written fonts and other fonts using xelatex?

This file can only be compiled by xelatex or lualatex

```

\documentclass{article}
\usepackage[no-math]{fontspec}

\setmainfont[
  Ligatures=TeX,
]{Architect}

\begin{document}
  This is some TEXT.
\end{document}

```

Then compile using `xelatex foo.tex`. The fonts used above, called `Architect` was downloaded from http://www.911fonts.com/font/download_StylusITCTTRegular_66.htm

See `using-handwriting-font-in-proofs` for more information.

Some fonts utilities on linux

```
kchselect
gfontsel
xfontsel
xlsfonts
chkfontpath
fslsfonts
```

It seems on Linux one needs to just create `$HOME/.fonts/` folder and put the `.tff` files there.

For example, I downloaded zip file from the above, extracted it, and copied one `.tff` file to

```
>pwd
/home/me/.fonts

>ls -l
-rwxr-xr-x 1 me me 36708 Sep 22 02:09 17273_architectbold.ttf
```

Now, make sure to rename the file above to match the actual font name as given inside the file. Double clicking on the file at least on windows, and look for the font name. do not use the file name itself. Must rename the file to match the font name. For the above, I did

```
>mv 17273_architectbold.ttf Architect-Bold.ttf
```

Since `Architect-Bold` was the actual font name.

And changed the latex file to the exact file name above as follows

```
\documentclass{article}
\usepackage[no-math]{fontspec}

\setmainfont[
  Ligatures=TeX,
]{Architect-Bold}

\begin{document}
  This is some TEXT.
\end{document}
```

The command `fc-cache` might be also useful to run after doing the above just in case. Use `xelatex` and not `lualatex` for the above. It seems there is difference on how fonts are found depending on which one to use. The above instructions are for `xelatex` which is what I used. It might work with `lualatex`, do not know now.

See `fontspec-xelatex-finding-fonts-by-name-installed-or-in-texmfhome`

To use `times` package, just add the line

3.44 How to use Times font for the whole document in Latex?

Just add this line

```
\usepackage{times}
```

See `how-do-you-change-the-document-font-in-latex` for more information.

3.45 how to pass variable to latex to change the compile content?

I use this method which works ok for me. I have a file called `switch.tex` where the switch is set to true or false. I have to edit this file to change the switch. Then in the main latex document, I input this file. This diagram shows the process.

```
\ifbool{switch}
{... latex code to compile when switch is true...}
{... latex code to compile when switch is false...}
```

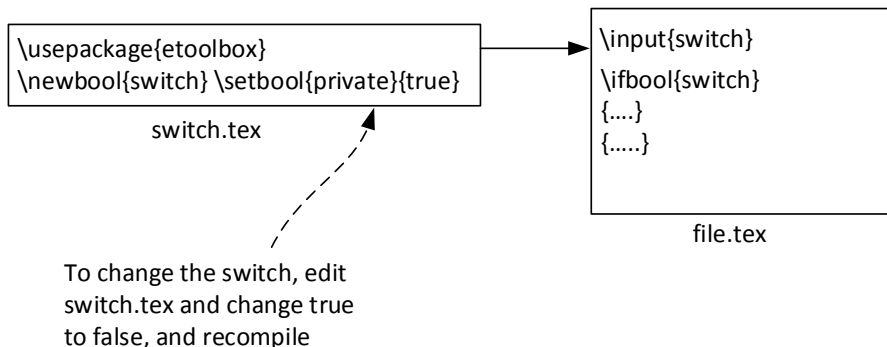

3.46 how to generate Latex from other programming languages?

This shows how to use other environments to generate Latex code. In Mathematica

```
s = ToString["\\documentclass[12pt,titlepage]{article}
\\begin{document}
It is known that  $\\sin(0)=$ " <> ToString[Sin[0]] <> "$
\\end{document}"];

file = OpenWrite["C:\\tmp\\p.tex", PageWidth -> Infinity];
WriteString[file, s];
Close[file];
```

This generates the Latex file p.tex

```
\\documentclass[12pt,titlepage]{article}
\\begin{document}
It is known that  $\\sin(0)=0$
\\end{document}$ 
```

Using Python

```
import math
s=r"""
\\documentclass[12pt,titlepage]{article}
\\begin{document}
It is known that  $\\sin(0)="""+repr(math.sin(0))+r"""$
\\end{document}"""

text_file = open(r"C:\tmp\p.tex", "w")
text_file.write(s)
text_file.close()$ 
```

The above generates the Latex file

```
\\documentclass[12pt,titlepage]{article}
\\begin{document}
It is known that  $\\sin(0)=0.0$
\\end{document}$ 
```

From C++ (needs C++11)

```
#include <iostream>
#include <string>
#include <math.h>
using namespace std;

int main()
{
    //int r = 5;
    string s =R"(

\documentclass[12pt,titlepage]{article}
\begin{document}
It is known that (a)  $\sin(\pi)=$ " + std::to_string(sin(M_PI)) + R"($
\end{document}

)";

    cout << s << endl;
    return 0;
}
```

And now compile and run

```
>g++ -Wall -std=c++0x try_string_literal.cpp
>./a.out

\documentclass[12pt,titlepage]{article}
\begin{document}
It is known that (a)  $\sin(\pi)=0.000000$ 
\end{document}
```

3.47 how to debug Latex?

Add `--debug --interactive`

3.48 How to find history of Tex? Family tree?

type `texdoc tex-overview.pdf`

3.49 Where to put a style file that is downloaded and not part of TeXLive?

```
cd `kpsewhich -var-value=TEXMFHOME`
```

and make directory `tex/latex/mystuff/` and put the file there.

Verify using `kpsewhich filename.sty`.

Reference: answer at [tex stackexchange](#)

3.50 How to convert pdf to eps?

```
pdftops -f 1 -l 1 -eps pic.pdf
```

3.51 what are values of extensions for images

Using this:

```
\documentclass[11pt,notitlepage]{article}%
\usepackage{graphicx}
\begin{document}

\makeatletter
\Gin@extensions
\makeatother

\end{document}
```

Compiled with `htlatex` gives

`.eps`, `.ps`, `.eps.gz`, `.ps.gz`, `.eps.Z`, `.mps`

and compiled with `pdflatex` gives

`.png`, `.pdf`, `.jpg`, `.mps`, `.jpeg`, `.jbig2`, `.jb2`, `.PNG`, `.PDF`, `.JPG`, `.JPEG`, `.JBIG2`, `.JB2`, `.eps`

And compiled with `lualatex` gives

`.png`, `.pdf`, `.jpg`, `.mps`, `.tif`, `.jpeg`, `.PNG`, `.PDF`, `.JPG`, `.JPEG`, `.eps`

3.52 How to include pdf pages as is in Latex

The number of pages of the pdf is first found, then a loop is used to load each page. Make sure to use `\clearpage` before, so that the first pdf page is on a new page and make sure to clear the page also after each page in the loop.

Here is an example

```
\usepackage{tikz}
\usepackage{pgffor}
....

\pdfximage{foo.pdf}
\foreach \n in {1,...,\the\pdfLASTximagepages}
{
\begin{tikzpicture}[remember picture,overlay]
  \node[inner sep=0pt] at (current page.center)
{
  \includegraphics[page=\n]{foo.pdf}};
  \end{tikzpicture}
  \clearpage
}
```

If you know the pdf file has only one page, then the following is enough

```
\clearpage
\begin{tikzpicture}[remember picture,overlay]
  \node[inner sep=0pt] at (current page.center)
{
  \includegraphics[page=1,scale=0.9]{foo.pdf}
};
\end{tikzpicture}
```

```
\clearpage
```

3.53 How to automatically build images needed for the latex file?

I put all my images needed for the document in an images/ folder below the main document folder. Using recursive make, the document Makefile has this line at its top

```
DIRS = images

include common.mk
...
```

Then the Makefile in the images/ file looks like this

```
DIRS =

include common.mk

FILES := $(shell ls -1 *.pdf)
#$(info $$FILES is [${FILES}])
TARGET = $(basename ${FILES})
#$(info $$TARGET is [${TARGET}])

all:: ${TARGET:=.svg}
    @echo "Finished building [?]"

%.svg : %.pdf
    prep $<

.PHONY: clean
clean ::
    -rm -f ${TARGET:=.svg}
```

Where prep is my script I use to crop the images and generate SVG image from each. Here it is

```
>cat `which prep`
#!/bin/bash
```

```
set -u
set -e
set -o pipefail

for file in $1; do
  filename=${file%.*}
  pdfcrop --margins 10 --clip "$filename.pdf" "$filename.pdf"
  pdf2svg "$filename.pdf" "$filename.svg"
#   pdftops -f 1 -l 1 -level3 -eps "$filename.pdf"
done
my_courses>
```

I use pdf file for the source of all the images. The above setup takes care of updating the images if one of them changes when compiling the latex file.

3.54 Some luatex examples using Lua inside Latex

3.54.1 Making counter

```
% !TEX TS-program = luatex
\documentclass{article}
\usepackage{luacode}
\usepackage{amsmath}
%-----
\begin{luacode}
local x = 0
function add()
  x = x + 1
  tex.print(x)
end

function sub()
  x = x - 1
  tex.print(x)
end

function reset()
  x = 0
```

```

end

\end{luacode}
\newcommand\add[0]{ \directlua{add()}}%
\newcommand\sub[0]{ \directlua{sub()}}%
\newcommand\reset[0]{ \directlua{reset()}}%
%-----
\begin{document}
\reset
\add
\add
\sub
\add
\end{document}

```

3.54.2 simplify fraction

see <http://tex.stackexchange.com/questions/253693/reducing-fraction-using-latex-3/253716#253716>

```

\documentclass{article}
\usepackage{luacode}
\usepackage{amsmath}
%-----
\begin{luacode}
function simplify(a,b)
  local function gcd(a,b)
    if b ~= 0 then
      return gcd(b, a % b)
    else
      return math.abs(a)
    end
  end
end

t = gcd(a, b)
tex.print("\frac{..a/t..}{..b/t..}")
end
\end{luacode}
\newcommand\simplify[2]{\directlua{simplify(#1,#2) }}%
%-----
\begin{document}

```

```
\noindent Can I make \LaTeX{} reduce a fraction automatically?\\[\baselineskip]
For example, I would like the fraction
\begin{equation*}
  \frac{278\,922}{74\,088}
\end{equation*}

to be reduced to

\begin{equation*}
  \simplify{278922}{74088}
\end{equation*}
\end{document}
```

The output of the above is

$$\frac{278\,922}{74\,088}$$

to be reduced to

$$27892274088$$

3.54.3 read CVS field to Latex table

This uses lua function to read the specific field in the CVS file. For example, given this CVS file in the directory

```
123,Poty city,Poti,red,-295731.42857144,617222.85714285
124,Lanchhuti city,Poti,red,-299217.14285715,647851.42857142
125,Ozurgeti city,Poti,red,-317217.14285715,648422.85714285
126,Samtredia city,Poti,red,-287502.85714287,672022.85714285
```

and you want to insert, say field located at row 2 and column 5, which is -299217.14285715 in the above, and field at row 1 and column 3, which is Poti then do

```
\begin{tabular}{|l|l|l|l|l|}\hline
  1 & \getField{1}{2} & 3 & 4 & 5 \\ \hline
  6 & 7 & 8 & \getField{2}{5} & 9 \\ \hline
  10 & 11 & 12 & 13 & 14 \\ \hline
\end{tabular}
```

The full code is below. I googled lua code to parse CVS files, there are few on the net, I found one that worked and used it. The CVS file is read automatically. Change the cvs file name in the code below and its path as needed. The latex file needs to be compiled with lualatex not pdflatex

```
\documentclass[]{article}
\usepackage{luacode}

\begin{luacode*} -- CVS API: http://nocurve.com/simple-csv-read-and-write-using-lua/
local function split(str, sep)
    fields={}
    local matchfunc = string.gmatch(str, "([^\s"..sep..""]+)" )
    if not matchfunc then return {str} end
    for str in matchfunc do
        table.insert(fields, str)
    end
    return fields
end

function read(path, sep, tonum)
    tonum = tonum or true
    sep = sep or ','
    local csvFile = {}
    local file = assert(io.open(path, "r"))
    for line in file:lines() do
        fields = split(line, sep)
        if tonum then -- convert numeric fields to numbers
            for i=1,#fields do
                fields[i] = tonumber(fields[i]) or fields[i]
            end
        end
        table.insert(csvFile, fields)
    end
    file:close()
    return csvFile
end

local m = read('./c.csv') -- read file csv file to local matrix m

function getField(row,col) -- API to latex command below
tex.print(m[row][col])
end
end
```

```

end

\end{luacode*}
\newcommand\getField[2]{\directlua{getField(#1,#2) }}%

\begin{document}

\begin{table}[]
  \centering
  \caption{My example}
  \begin{tabular}{|1|1|1|1|1|1|}\hline
    1 & \getField{1}{2} & 3 & 4 & 5 \\ \hline
    6 & 7 & 8 & \getField{2}{5} & 9 \\ \hline
    10 & 11 & 12 & 13 & 14 \\ \hline
  \end{tabular}
\end{table}

\end{document}

```

reference tex stackexchange

This below reads a while CVS file to a latex table

```

\documentclass[]{article}
\usepackage{luacode}

\begin{luacode*} -- CVS API thanks to http://nocurve.com/simple-csv-read-and-write-using-lua
  local function split(str, sep)
    fields={}
    local matchfunc = string.gmatch(str, "([^\s"..sep.." ]+)" )
    if not matchfunc then return {str} end
    for str in matchfunc do
      table.insert(fields, str)
    end
    return fields
  end

function read(path, sep, tonum)
  tonum = tonum or true
  sep = sep or ','
  local csvFile = {}
  local file = assert(io.open(path, "r"))

```

```
    for line in file:lines() do
        fields = split(line, sep)
        if tonum then -- convert numeric fields to numbers
            for i=1,#fields do
                fields[i] = tonumber(fields[i]) or fields[i]
            end
        end
        table.insert(csvFile, fields)
    end
    file:close()
    return csvFile
end

function getCVS(fileName)
    local m = read(fileName) -- read file csv1.txt to matrix m
    local nRow = #m
    local nCol = #m[1]

    tex.sprint("\\begin{tabular}{")
    for j=1,#m[1] do
        tex.sprint("|l")
    end
    tex.print("|}\\hline")

    for i = 1,nRow do
        for j = 1,nCol do
            tex.sprint(m[i][j])
            if j<nCol then tex.sprint("&") end
        end
        tex.print("\\\\ \\hline")
    end
    tex.print("\\end{tabular}")
end

\\end{luacode*}
\\newcommand\\getCVS[1]{\\directlua{getCVS(#1) }}%

\\begin{document}

\\begin{table}[]
    \\centering
```



```

    \caption{My CVS file in a Latex table}
    \getCVS{"c.cvs"}
\end{table}

\end{document}

```

3.54.4 reversing enumeration list

Given enumeration list, where each item just uses one line, to reverse it:

```

% !TEX TS-program = lualatex
\documentclass{article}
\usepackage{luacode}
\usepackage{amsmath}
%-----
\begin{luacode*} -- copy the list here as is.
data=[[
\item 2001
  \item 2002
  \item 2003
  \item 2005 was a very good year
  \item 2006 was also a very good year
  \item 2007
]]

function string:split(sep) --http://lua-users.org/wiki/SplitJoin
  local sep, fields = sep or ":", {}
  local pattern = string.format("(^[^%s]+)", sep)
  self:gsub(pattern, function(c) fields[#fields+1] = c end)
  return fields
end

function flip()
  lines = data:split("\n")
  tex.print("\begin{enumerate}")
  for i=#lines,1,-1 do
    tex.print(lines[i])
  end
  tex.print("\end{enumerate}")
end
\end{luacode*}
\newcommand\flip[0]{ \directlua{flip()}}%

```

```
\begin{document}
\flip{}
\end{document}
```

Another way is

```
% !TEX TS-program = lualatex
\documentclass{article}
\usepackage{luacode}
\usepackage{amsmath}

%-----
\begin{luacode*}
function split(str, pat) --http://lua-users.org/wiki/SplitJoin
  local t = {} -- NOTE: use {n = 0} in Lua-5.0
  local fpat = "(.*)" .. pat
  local last_end = 1
  local s, e, cap = str:find(fpat, 1)
  while s do
    if s ~= 1 or cap ~= "" then
      table.insert(t, cap)
    end
    last_end = e+1
    s, e, cap = str:find(fpat, last_end)
  end
  if last_end <= #str then
    cap = str:sub(last_end)
    table.insert(t, cap)
  end
  return t
end

function flip(data)
  items = split(data, "\\item")
  tex.print("\\begin{enumerate}")
  for i=#items,1,-1 do
    tex.print("\\item " .. items[i])
  end
  tex.print("\\end{enumerate}")
end
```

```
\end{luacode*}
%-----

\begin{document}
This is my enumeration list
\begin{enumerate}
  \item 2001
  \item 2002
  \item 2003
\end{enumerate}

Here it is flipped:
\directlua{flip(\luastring{\unexpanded{%
  \item 2001
  \item 2002
  \item 2003
}}})}
\end{document}
```

The result of the above is

This is my enumeration list

1. 2001
2. 2002
3. 2003

Here it is flipped:

1. 2003
2. 2002
3. 2001

CHAPTER 4

TEX4HT CHEAT SHEET

4.1 my tex4ht setup using SVG for math

description of my tex4ht setup

4.2 Showing where files needed by make4ht and tex4ht are on my PC

Picture of where things are on my PC for use with tex4ht and make4ht

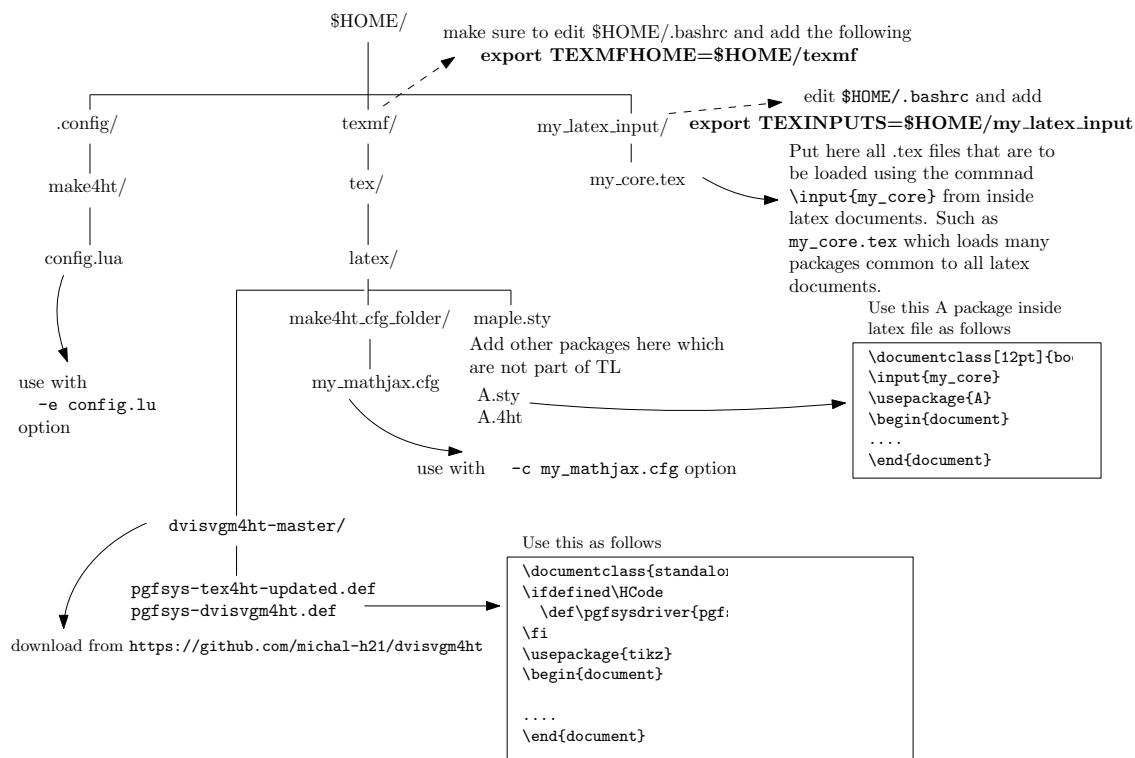

Figure 4.1: my tex4ht/make4ht configuration

4.3 my tex4ht setup using mathjax for math

This is updated on January 16, 2019. Using latest texlive, now mathjax is integrated in tex4ht. So the way to use mathjax is as simple as this

```
make4ht foo.tex "htm,mathjax"
```

The above is minimal call. My actual call is this

```
make4ht -ulm default -e ~/new.mk4 -c ~/nma_mathjax.cfg
foo.tex "htm,0,mathjax,notoc*,p-width,charset=utf-8" " -cunihtf -utf8"
```

Where 0 above is split level, which can be 1 or 2 or 3 and so on.

And nma_mathjax.cfg is

```

\Preamble{xhtml}

%This trick below is to allow using \DeclareGraphicsExtensions
%only when the graphics package is loaded. Thanks to Michal Hoftich for
%this work around. Updated Oct 10, 2018.

\makeatletter
\ifpackageloaded{graphicx}{% ONLY use if graphics package is loaded.
  \DeclareGraphicsExtensions{.svg,.png}
  \Configure{Picture}{.svg}
  %this below to make it resize the SVG image, if it is there, to
  %what is in the includegraphics.
  %thanks to @Michael.h21 for this trick
  \newcommand\emwidth{10}
  % convert pt to rem
  \newcommand\CalcRem[1]{\strip@pt\dimexpr(#1)/\emwidth}
  \Configure{graphics*}
    {svg}
    {\Picture[pict]{\csname Gin@base\endcsname.svg
  \space style="width:\CalcRem{\Gin@req@width}em;"
  }%
  \special{t4ht+@File: \csname Gin@base\endcsname.svg}
  }
}
{}
\makeatother

\begin{document}
\edef\mymathjaxconf{\detokenize{MathJax.Hub.Config({
  TeX: {
    MAXBUFFER: 40*1024,
    Macros : {
relax: "{}",
setlength: ["{}", 2],
allowbreak: "{}",
}},
});}}

```

```

\ExplSyntaxOn
\regex_replace_all:nnN{ \x{23}\x{23}}{\x{23}}{\mymathjaxconf}
\ExplSyntaxOff

\Configure{@HEAD}{\HCode{<script
type="text/x-mathjax-config"> \mymathjaxconf</script>}}

\EndPreamble

```

And the file `new.mk4` is

```

if mode == "draft" then
  Make:htlatex {}
else
  Make:htlatex {}
  Make:htlatex {}
  Make:htlatex {}
end

```

Remember NOT to use `pic-align` option in the above. This causes problems with mathjax. Also notice the extra space in "`-cunihtf -utf8`"

4.4 tex4ht themes

Before starting, here are rules of thumb to remember. Most of these rules will cover most of the common uses.

1. If using the report class and if `splitting` is set to 2, then each chapter (and anything in it, such as sections and subsections) all go to separate one web page).
2. If using the report class and if `splitting` is set to 3, then each section (and anything in it, such as subsections) all go to separate one web page).
3. If using report class, to Force a table of content to show under each chapter add this `\TocAt{chapter,section} %show sections only in chapters TOC`
4. To Force a table of content to show under each section add this `\TocAt{section,subsection} %sh`
5. If using article class, then using `split 2` then each section is put on its own page (including all its subsections).

6. If using article class, then using split 3 will put each section on its page, and each subsection (and everything inside subsections) on its own page.

The general outlines of the themes below are needed if one wants to do something more complicated than the above rules of thumb.

These themes were done using the command

```
htlatex foo.tex "htm,3"
```

And then adding the control of where to split pages to separate HTML pages or not, and controlling where table of contents show up right inside the latex file. This is needed since there is no other way to control which sections or chapters to split or not to split using global method, and so the logic has to be embedded inside the latex file.

All logic for both pdf and htlatex is inside the same file and is controlled using `\ifdefined\HCode` to tell if one is running in pdf or htlatex, since only generation to HTML and PDF is done here.

4.4.1 theme 1

report class, main TOC shows only chapters. Chapter 2 has TOC and all its sections in one web page, but chapter 1 has TOC but its sections are each on separate web pagebreak

This is compiled using

```
htlatex foo.tex "htm,3"
```

1. HTML output of this theme is HTML
2. PDF output of this theme is PDF

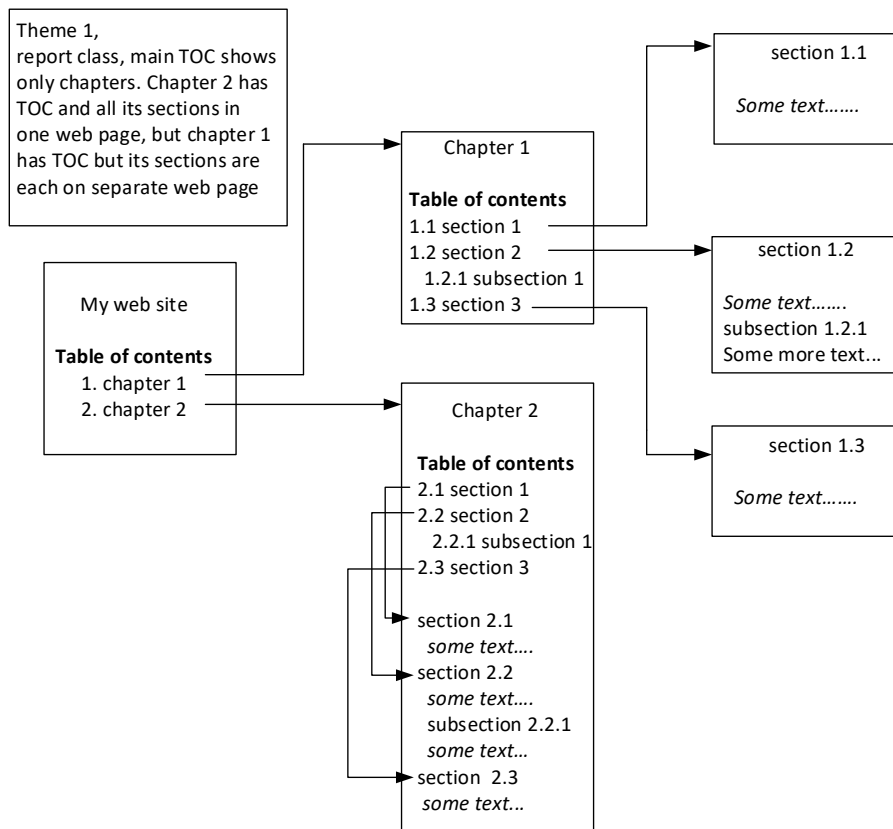

```

\documentclass{report}
\setcounter{tocdepth}{0}
\setcounter{secnumdepth}{4}
\usepackage{lipsum}
\usepackage{titletoc}

\begin{document}

\title{my web site}
\author{me}
\date{\small\today}
\maketitle

%tell tex4ht to make main toc show only chapters
%thanks to Radhakrishnan CV for this solution
\ifdefined\HCode
\Configure{tableofcontents*}{chapter}
\fi

```

```
\tableofcontents

\ifdefined\HCode
\TocAt{chapter,section} %show section only in chapters TOC
\TocAt{section,subsection} %show subsection only in sections TOC
\fi

%-----
\chapter{chapter 1}
\ifdefined\HCode
\else
{
\startcontents[chapter]
\printcontents[chapter]{}{1}{\setcounter{tocdepth}{1}}
}
\fi
  \lipsum[10]

  \section{section 1 in chapter 1}
  \lipsum[1-2]

  \section{section 2 in chapter 1}
  \lipsum[1-2]
  \subsection{subsection 1 in section 2 in chapter 1}
  \lipsum[1-2]

  \section{section 3 in chapter 1}
  \lipsum[1-2]

%-----

\ifdefined\HCode
\PauseCutAt{section}
\fi

\ifdefined\HCode
\else
{
\stopcontents[chapter]
}
\fi
```

```
\chapter{chapter 2}
  \lipsum[10]

  \section{section 1 in chapter 2}
  \lipsum[1-2]

  \section{section 2 in chapter 2}
  \lipsum[1-2]
  \subsection{subsection 1 in section 2 in chapter 2}
  \lipsum[1-2]

  \section{section 3 in chapter 2}
  \lipsum[1-2]

\end{document}
```

4.4.2 theme 2

There seems to be an issue somewhere, I need to resolve. This is getting complicated.

1. HTML output of this theme is HTML
2. PDF output of this theme is PDF

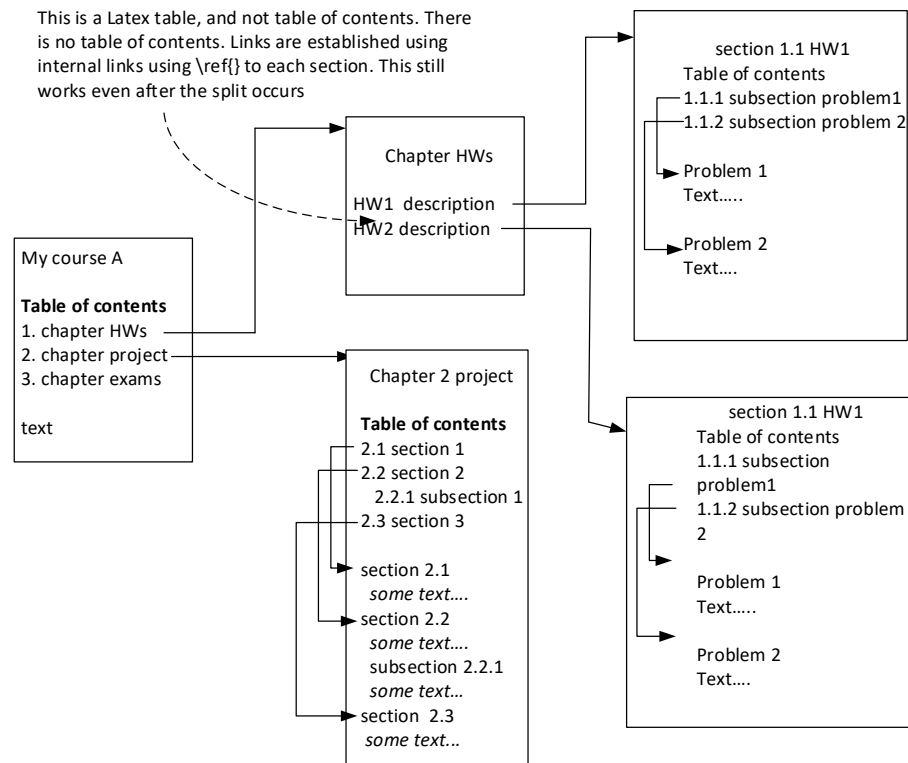

```

\documentclass{report}
\setcounter{tocdepth}{0}
\setcounter{secnumdepth}{4}
\usepackage{lipsum}
\usepackage{titletoc}

\begin{document}

\title{my course A}
\author{me}
\date{\small\today}
\maketitle

\ifdefined\HCode
\Configure{tableofcontents*}{chapter}
\fi

\tableofcontents

\ifdefined\HCode

```

```

\TocAt{chapter} %turn off TOC
\fi

%-----
\chapter{chapter 1 my HWs}

\begin{tabular}{|l|l|}
\hline
HW & grade \\ \hline
HW1 & \ref{sec:HW1} & 100\% \\ \hline
HW2 & \ref{sec:HW2} & 100\% \\ \hline
\end{tabular}

\ifdefined\HCode
\TocAt{section,subsection} %turn on TOC
\fi
\section{HW 1}
\ifdefined\HCode
\else
{ %turn on local TOC
\startcontents[section]
\printcontents[section]{}{1}{\setcounter{tocdepth}{1}}
}
\fi

\label{sec:HW1}
\subsection{problem 1}
\lipsum[10]
\subsection{problem 2}
\lipsum[10]
\subsection{problem 3}
\lipsum[10]

\section{HW 2}
\label{sec:HW2}
\subsection{problem 1}
\lipsum[10]
\subsection{problem 2}
\lipsum[10]
\subsection{problem 3}
\lipsum[10]

```

```

\ifdefined\HCode
\TocAt{chapter,section} %turn on TOC
\PauseCutAt{section} % do not SPLIT this section
\fi

%-----
\chapter{project}
\ifdefined\HCode
\else
{ %turn on local TOC
\startcontents[chapter]
\printcontents[chapter]{}{1}{\setcounter{tocdepth}{1}}
}
\fi

\section{introduction}
\lipsum[10]
\section{design}
\lipsum[10]
\section{appendix}
\lipsum[10]

\end{document}

```

4.5 How to make tex4ht and pdflatex work in the same file?

There are number of ways to add htlatex commands to latex document. But the document has to still work with pdflatex.

Here is one way to do it, using `ifx`

```

\documentclass{report}
\usepackage{hyperref}
\begin{document}
\tableofcontents

\ifx\HCode\undefined \else

```

```
\href{foo.htm}{HTML}
\TocAt{chapter,section,subsection,subsubsection}
\fi

\chapter{chapter 1}
\section{section 1 in chapter 1}
\subsection{subsection 1 in section 1 in chapter 1}
\subsection{subsection 2 in section 1 in chapter 1}
\subsubsection{subsubsection 1 subsection 2 in section 1 in chapter 1}

\end{document}
```

Another way is to use HCode

```
\documentclass{report}
\usepackage{hyperref}
\begin{document}
\tableofcontents

%-----
\ifdefined\HCode
\href{foo.htm}{HTML}
\TocAt{chapter,section,subsection,subsubsection}
\fi

\chapter{chapter 1}
\section{section 1 in chapter 1}
\subsection{subsection 1 in section 1 in chapter 1}
\subsection{subsection 2 in section 1 in chapter 1}
\subsubsection{subsubsection 1 subsection 2 in section 1 in chapter 1}

\end{document}
```

4.6 Adding tex4ht configuration inside latex file instead of using .cfg

One can use `\Configure` after `\begin{document}`

These are from Michal Hoftich.

```
(untested, just an idea):

\documentclass{article}
\ifdefined\HCode
\newcommand\html[1]{%
\HCode{#1}%
}%
\else
\newcommand\html[1]{}%
\fi
\begin{document}
\html{<div class="hello">world</div>}
\end{document}
```

And

You don't need `\Preamble` and `\EndPreamble` in your document, they are useful only in config file. You can use `\Css`, `\Tg` or `\ConfigureEnv`, but only after `'\begin{document}'`. Something like this should work:

```
\documentclass{article}
\usepackage{somepackage}
\begin{document}
\ifx\HCode\undefined \else
\Css{body{background-color:green;}}
\ConfigureEnv{quote}{\Tg<quote>}{\Tg</quote>}{}{}
\fi
```

`\ifx\HCode` will ensure that this code run only when tex4ht is loaded.

4.7 removing the extra TOC on main page

Problem: Running this generates an extra TOC

```
htllatex foo.tex "htm,2"

%-----
\documentclass{article}%
\usepackage{ifpdf}
\usepackage{lipsum}

\begin{document}
\title{test toc}
\author{me}
\date{\today}
\maketitle

\tableofcontents

\section{section 1}
  \lipsum{1}
  \subsection{subsection 1}
  text
\section{section 2}
  \lipsum{1}
\section{section 3}
  \lipsum{1}

\end{document}
```

One solution is this:

```
htllatex foo_split.tex "htm,0"

-----

\documentclass{article}%
\usepackage{ifpdf}
\usepackage{lipsum}

\begin{document}
\title{test toc}
```

```
\author{me}
\date{\today}
\maketitle

\ifx\HCode\undefined \else
\CutAt{section}      % tell is to cut as if we did "htm,2", make
\fi                  % section separate

\tableofcontents

\section{section 1}
  \lipsum{1}
  \subsection{subsection 1}
  text
\section{section 2}
  \lipsum{1}
\section{section 3}
  \lipsum{1}

\end{document}
```

Another is (thanks to Radhakrishnan) is

```
htllatex foo.tex "html,2,notoc*"

\documentclass{article}%
\usepackage{ifpdf}
\usepackage{lipsum}

\begin{document}
\title{test toc}
\author{me}
\date{\today}
\maketitle

\tableofcontents

\section{section 1}
  \lipsum{1}
  \subsection{subsection 1}
```

```

    text
\section{section 2}
    \lipsum{1}
\section{section 3}
    \lipsum{1}

\end{document}

```

4.8 Changing the depth of the main toc in HTML

To change how deep the TOC is on the main page in HTML, do the following. Suppose we want to show chapter, section, subsection, and subsubsection in the TOC, then here is an example

```

\begin{document}

\title{my dynamics cheat sheet}
\author{{\small Nasser M. Abbasi}}
\date{{\small \today}}
\maketitle

\ifdefined\HCode
    \Configure{tableofcontents*}{chapter,section,subsection,subsubsection}
\fi

\tableofcontents

```

Splitting the document (html) based on section is different. This is handled as follows. Suppose we want to split by 2, then compile as

```
make4ht foo.tex "htm,2,charset=utf-8,pic-align,notoc*" " -cunihtf -utf8"
```

If you are using a htlatex .cfg file, say my.cfg, then change the above to be

```
make4ht foo.tex "my,htm,2,charset=utf-8,pic-align,notoc*" " -cunihtf -utf8"
```

Notice the use of `notoc*`

4.9 making local TOC at some units but not in others

tex4ht does not support minitoc. And could not make it to work with titletoc either.

One way to simulate it, is to use `\TocAt{}` inside the document, like this:

```
pdflatex foo.tex
htlatrix foo.tex "htm"
htlatrix foo.tex "htm,2"

\documentclass{report}%
\usepackage{ifpdf}
\usepackage{lipsum}
\usepackage{minitoc}

\begin{document}

\title{test minTOC with tex4ht}
\author{me}
\date{\today}
\maketitle

\ifdefined\HCode
\else
\dominitoc %only for pdf
\fi

\tableofcontents

\ifdefined\HCode
\TocAt{chapter,section,subsection} %do it before chapter
\fi

\chapter{chapter 1}
\ifdefined\HCode
\else
\minitoc
\fi

\lipsum{1}
```

```

\section{section 1 under chapter 1}
  text
\subsection{subsection 1 under section 1 under chapter 1}
  text
\subsubsection{subsubsection 1}

\ifdefined\HCode
\TocAt{chapter} %RESET it to NO TOC before chapter
\fi

\chapter{chapter 2}

\lipsum{1}
\section{section 1 under chapter 2}
\end{document}

```

4.10 how to use tikz picture with math in htlatex?

Assuming the latex file is foo2.tex

```

\documentclass{article}
\ifdefined\HCode
\def\pgfsysdriver{pgfsys-tex4ht.def}
\fi
\usepackage{tikz,graphicx}
%
\usetikzlibrary{trees}
\begin{document}
\begin{tikzpicture}
  \node {root}
    child {node { $\frac{a}{b}$ }};
\end{tikzpicture}
\end{document}

```

The file is compiled as

```
htlatex foo2.tex "my.cfg,charset=utf-8" " -cunihtf -utf8"
```

where my.cfg is

```

\Preamble{xhtml,mathml}
\Configure{VERSION}{}
\Configure{DOCTYPE}{\HCode{<!DOCTYPE html>\Hnewline}}
\Configure{HTML}{\HCode{<html>\Hnewline}}{\HCode{\Hnewline</html>}}
\Configure{@HEAD}{}
\Configure{@HEAD}{\HCode{<meta charset="UTF-8" /\Hnewline}}
\Configure{@HEAD}{\HCode{<meta name="generator" content="TeX4ht
(http://www.cse.ohio-state.edu/~string~gurari/TeX4ht/) " /\Hnewline}}
\Configure{@HEAD}{\HCode{<link
    rel="stylesheet" type="text/css"
    href="\expandafter\csname aa:CssFile\endcsname" /\Hnewline}}
\Configure{@HEAD}{\HCode{<script type="text/javascript"\Hnewline
src="http://cdn.mathjax.org/mathjax/latest/MathJax.js?config=TeX-AMS-MML_HTMLorMML"\Hnewline
></script>\Hnewline}}
\Configure{@HEAD}{\HCode{<style type="text/css">\Hnewline
    .MathJax_MathML {text-indent: 0;}\Hnewline
</style>\Hnewline}}
\begin{document}
\EndPreamble

```

Now the file foo2.html will display in the browser as

root

notice: The math does not show up in the HTML. This is a known issue with using math+tickz+htlatex see <http://tex.stackexchange.com/questions/124682/error>

-using-htlatex-with-tikz-forest-package-invalid-svg-generated

A better approach is this: Use separate latex file to make the diagram using tikz. Use standalone class. Then generate the pdf file using pdflatex.

Next convert the pdf to png, then using a separate latex file, include this image as png where it needs to go. This way htlatex and pdflatex will be able to process it ok. Here are the steps.

1. make separate latex file for each diagram. For example `diagram.tex`

```
\documentclass{standalone}
\usepackage{tikz}
}
\usetikzlibrary{trees}
\begin{document}
\begin{tikzpicture}
\node {root}
  child {node {$\frac{a}{b}$}};
\end{tikzpicture}
\end{document}
```

2. compile the above file to pdf

```
pdflatex diagram.tex
```

3. convert the pdf file to png

```
pdftoppm -png diagram.pdf > diagram.png
or
convert -density 200 -limit memory 64MB -limit map 128MB -colorspace RGB diagram.pdf di
\begin{TEXTinline}
%
\item create the latex file which will use the above diagram, say \verb|main.tex|

\begin{TEXTinline}
\documentclass{article}
\usepackage{graphicx}

\begin{document}

The following diagram was generated using tikz+latex in
```



```
a separate file

\includegraphics{diagram.png}

and it is now in html
\end{document}
```

- now make pdf and html files from the above

```
pdflatex main.tex
htltx main.tex
```

- now the files `main.pdf` and `main.html` can be used.

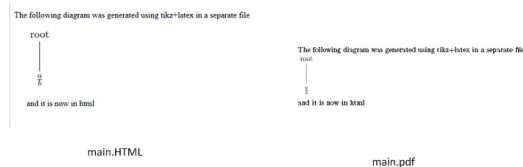

added 020814 Some examples with math do work in htltx. Here is a nice picture in tikz with math on it, that htltx was able to process with no error. This is using texlive 2013 version.

I did not have to use standalone as workaround as in the above example to make the math show up. I am using the code as shown in this post <http://tex.stackexchange.com/questions/158668/nice-scientific-pictures-show-off> by Paul Gessler. Here are the steps to convert this to HTML using htltx and the result obtained

- make the `foo.tex` file using your editor (copy from the above link)

```
\documentclass{standalone}
\usepackage{tikz} % TikZ and PGF

% Vector Styles
\tikzstyle{load} = [ultra thick,-latex]
\tikzstyle{stress} = [-latex]
\tikzstyle{dim} = [latex-latex]
\tikzstyle{axis} = [-latex,black!55]

% Drawing Views
\tikzstyle{isometric}=[x={(0.710cm,-0.410cm)},y={(0cm,0.820cm)},z={(-0.710cm,-0.410cm)}
```

```

\tikzstyle{dimetric} = [x={(0.935cm,-0.118cm)},y={(0cm,0.943cm)},z={(-0.354cm,-0.312cm)}
\tikzstyle{dimetric2}=[x={(0.935cm,-0.118cm)},z={(0cm,0.943cm)},y={(+0.354cm,+0.312cm)}
\tikzstyle{trimetric}=[x={(0.926cm,-0.207cm)},y={(0cm,0.837cm)},z={(-0.378cm,-0.507cm)}

\begin{document}
\begin{tikzpicture}
  \node (origin) at (0,0) {}; % shift relative baseline
  \coordinate (O) at (2,3);
  \draw[fill=gray!10] (O) circle (1);
  \draw[fill=white] (O) circle (0.75) node[below,yshift=-1.125cm] {Signpost Cross Section};
  \draw[dim] (O) ++(-0.75,0) -- ++(1.5,0) node[midway,above] {$d_i$};
  \draw[dim] (O) ++(-1,1.25) -- ++(2,0) node[midway,above] {$d_o$};
  \foreach \x in {-1,1} {
    \draw (O) ++(\x,0.25) -- ++(0,1.25);
  }
\end{tikzpicture}
\begin{tikzpicture}[dimetric2]
  \coordinate (O) at (0,0,0);
  \draw[axis] (O) -- ++(6,0,0) node[right] {$x$};
  \draw[axis] (O) -- ++(0,6,0) node[above right] {$y$};
  \draw[axis] (O) -- ++(0,0,6) node[above] {$z$};
  \draw[fill=gray!50] (0,0,-0.5) circle (0.5);
  \fill[fill=gray!50] (-0.46,-0.2,-0.5) -- (0.46,0.2,-0.5) -- (0.46,0.2,0) -- (-0.46,0.2,0);
  \draw[fill=gray!20] (O) circle (0.5);
  \draw (0.46,0.2,-0.5) -- ++(0,0,0.5) node[below right,pos=0.0] {Fixed Support};
  \draw (-0.46,-0.2,-0.5) -- ++(0,0,0.5);
  \draw[fill=gray!10] (O) circle (0.2);
  \fill[fill=gray!10] (-0.175,-0.1,0) -- (0.175,0.1,0) -- ++(0,0,4) -- (-0.175,-0.1,4);
  \draw (-0.175,-0.1,0) -- ++(0,0,4);
  \draw (0.175,0.1,0) -- ++(0,0,4) node[right,midway] {Steel Post};
  \draw (4,0,3.95) -- ++(0,0,-1);
  \foreach \z in {0.5,0.75,...,5} {
    \draw[-latex] (-2*\z/5-0.2,0,\z) -- (-0.2,0,\z);
  }
  \draw[load] (0,0,4) -- ++(0,0,-1.25) node[right,xshift=0.1cm] {$F_{z1}$};
  \draw[fill=gray!20] (-0.25,-0.25,5) -- (4,-0.25,5) -- (4,+0.25,5) -- (-0.25,+0.25,5);
  \draw[fill=gray!50] (+4.00,-0.25,4) -- (4,+0.25,4) -- (4,+0.25,5) -- (+4.00,-0.25,5);
  \draw[fill=gray!10] (-0.25,-0.25,4) -- (4,-0.25,4) -- (4,-0.25,5) -- (-0.25,-0.25,5);
  \draw (4.05,0,4) -- ++(1,0,0);
  \draw (4.05,0,5) -- ++(1,0,0);
  \draw[dim] (4.5,0,0) -- ++(0,0,4) node[midway,right] {$h_1$};

```

```

\draw[dim] (4.5,0,4) -- ++(0,0,1) node[midway,right] {$h_2$};
\draw[dim] (0,0,3.4) -- ++(4,0,0) node[midway,below] {$b_2$};
\coordinate (P) at (2,-0.25,4.5);
\draw (P) -- ++(0,0,0.25);
\draw (P) -- ++(0.25,0,0);
\draw[dim] (2.125,-0.25,4.5) -- ++(0,0,-0.5) node[midway,right] {$z_1$};
\draw[dim] (2,-0.25,4.625) -- ++(-2,0,0) node[midway,below] {$x_1$};
\draw[load] (2,-2.45,4.5) -- ++(0,2.2,0) node[pos=0.0,right,xshift=0.08cm] {$F_{y1}$};
\draw[axis,dashed,-] (0) -- (0,0,5);
\draw (0,0,5.5) -- ++(4,0,0) node[midway,above] {$w_z$};
\foreach \x in {0,0.25,...,4} {
  \draw[-latex] (\x,0,5.5) -- ++(0,0,-0.5);
}
\draw (-0.2,0,0) -- ++(-2,0,5) node[above,xshift=0.5cm] {$w_x=\frac{z}{h_1+h_2}$};
\end{tikzpicture} %
\end{document}

```

2. compile using this his command

```
htlatex foo.tex "my.cfg,htm,charset=utf-8" " -cunihtf -utf8"
```

it is important to use `my.cfg` because without it, you'll get an error. The `cfg` file is the one shown above. Just copy that and put it in the same location as the `tex` file.

3. here is the HTML generated by the above. HTML should display as

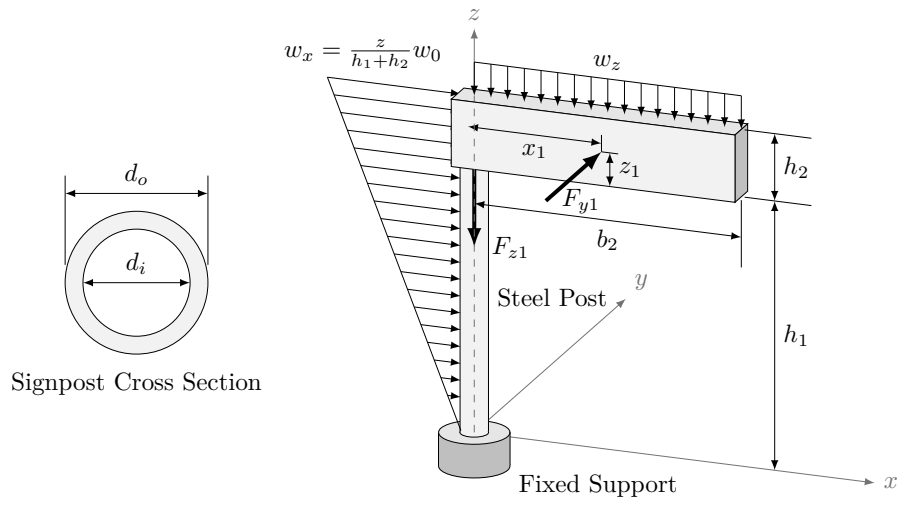

4.11 how to change font for HTML math when using tex4ht

To increase fonts in tex4ht

if using 12 pt in document class, add this line after the `\document` section in the .cfg file

```
\DeclareMathSizes{12}{14}{10}{8}
\DeclareMathSizes{12}{16}{12}{10} %----> for {\Large}
```

(note, `\Large` in a 12pt article is 17.28pt)

The size of math's font changes also with `\Large`

To make Math look better, see this

<http://tex.stackexchange.com/questions/43772/latex-xhtml-with-tex4ht-bad-quality-images-of-equations>

4.12 tex4ht options

Example The command `htlatex myfile "mycfg,2"` requests the compilation of a file named `myfile.tex`, in the presence of a configuration file named `mycfg.cfg`. The configuration file might have the following content.

```
\Preamble{html}
\begin{document}
  \Css{body { color : red; }}
\EndPreamble
```

4.13 How to use tex4ht with pdf and latex in same document?

use this

```
\documentclass[titlepage]{article}%
\usepackage{ifpdf}
\usepackage{hyperref}

\begin{document}

\ifpdf
    I am in pdf mode % pdflatex code,will show up in pdf only
\else
    % latex code, check if htlatex is loaded and use link only then
    \ifdefined\HCode
        \href{../../index.htm}{home} % show up in HTML only
    \else
        I am in latex mode % shows up in dvi and .ps only but not in html
    \fi
\fi

\end{document}
```

4.14 my setup for using htlatex on linux, installing make4ht

1. typed `kpsewhich -var-value TEXMFHOME`
to find where \TeX will look for files.
2. edits my `.basrc` and added this

```
export TEXMFHOME=$HOME/texmf
export PATH=$HOME/texmf/scripts/lu/make4ht-master:$PATH
```

3. I use now `make4ht` to build latex to html (new builder in place of `htlatex`).
Downloaded it from

<https://github.com/michal-h21/make4ht>

and extracted the zip file below $\$TEXHMF/scripts/$ lua folder.

```
>unzip make4ht-master.zip
Archive:  make4ht-master.zip
5417507d156b01aded3371efc2d5b71074bb0afe
  creating:  make4ht-master/
  inflating: make4ht-master/README.md
  inflating: make4ht-master/lapp-mk4.lua
  inflating: make4ht-master/make4ht
  inflating: make4ht-master/make4ht-lib.lua
  inflating: make4ht-master/mkparams.lua
  inflating: make4ht-master/mkutils.lua
>cd make4ht-master/
```

So the tree looks like this

```
cd $HOME
tree texmf

texmf
|__+ scripts
  |__lua
    |__make4ht-master
      |-- lapp-mk4.lua
      |-- make4ht
      |-- make4ht-lib.lua
      |-- mkparams.lua
      |-- mkutils.lua
      |-- README.md
```

4. make sure you have convert, if not do `sudo apt-get install imagemagick`
5. make sure you have lua, if not do `sudo apt-get install lua5.2` (may be not needed)
6. the command to build latex to html is

```
make4ht foo.tex "nma.cfg,htm,charset=utf-8" " -cunihtf -utf8" "-dfoo"
```

where nma.cfg is currently here nma.cfg

7. in the latex files, I include one file in the preamble which has all the packages to use. Here it is `commonlatex.tex`
8. example latex file will then be as this

```
\documentclass[]{article}
\input{commonlatex}
\begin{document}

\end{document}
```

9. when first installing, need to fix `tex4ht.env` so that `.png` images are better quality. See <http://tex.stackexchange.com/questions/43772/latex-xhtml-with-tex4ht-bad-quality-images-of-equations> Use the `<dvipng>` by erasing the space before it and add space before the `<convert>` section.

```
>locate tex4ht.env
/usr/local/texlive/2013/texmf-dist/doc/latex/latex-web-companion/ch4/tex4ht.env
/usr/local/texlive/2013/texmf-dist/tex4ht/base/unix/tex4ht.env
/usr/local/texlive/2013/texmf-dist/tex4ht/base/win32/tex4ht.env

>cd /usr/local/texlive/2013/texmf-dist/tex4ht/base/unix
>sudo cp tex4ht.env tex4ht.env.SAVED
>sudo vi tex4ht.env
>

>diff tex4ht.env tex4ht.env.SAVED
153c153
< <convert>
---
> <convert>
170c170
< </convert>
---
> </convert>
183c183
< <dvipng>
---
> <dvipng>
185c185
```



```

< Gdvipng -T tight -x 1400 -D 96 -bg Transparent -pp %2:%2 %1 -o %3
---
> Gdvipng -T tight -x 1400 -D 72 -bg Transparent -pp %2:%2 %1 -o %3
187c187
< Gdvipng -T tight -x 1400 -D 96 -bg Transparent -gif -pp %2:%2 %1 -o %3
---
> Gdvipng -T tight -x 1400 -D 72 -bg Transparent -gif -pp %2:%2 %1 -o %3
192c192
< </dvipng>
---
> </dvipng>
>

```

4.15 how to insert HTML code inside the body of a latex document?

Here is an example to insert only ONE HTML line

```

\documentclass{article}%
\input{commonlatex}

\begin{document}

\ifdefined\HCode
\Css{body{width:70\%;}} %this will be inserted in the HTML, only when using htlatex
\fi

\end{document}

```

To insert large amount of HTML code, use Radhakrishnan CV method:

```

\documentclass{article}
\begin{document}

\ScriptEnv{html}
{\NoFonts\hfill\break}
{\EndNoFonts}

```

```
\begin{html}
<h2>This is HTML head 2 </h2>

more HTML code
\end{html}

\end{document}
```

reference: <http://tug.org/pipermail/tex4ht/2013q3/000823.html>

4.16 How to control page margins in html

To control page margins in html, can do it in html or css.

HTML method (add code the BODY tag of your web page source code):

```
<BODY LEFTMARGIN="10" TOPMARGIN="10" MARGINWIDTH="10" MARGINHEIGHT="10">
```

CSS method (add code to the BODY tag of your external style sheet):

```
body {margin-top: 10px;
margin-right: 10px;
margin-bottom: 10px;
margin-left: 10px;}
```

To change margins in html output of htlatex, use the following .cfg file for htlatex

```
\Preamble{html}
\begin{document}
\Css {body {margin-top: 10px;
           margin-right: 10px;
           margin-bottom: 10px;
           margin-left: 50px;
         }
      }
\EndPreamble
```

and then type `htlatex foo.tex "foo.cfg"`

4.17 tex4ht and table of content issues

see <http://tex.stackexchange.com/questions/44541/tex4ht-limit-toc>

I use this command to get table of content to be full in tex4ht

```
htllatex index.tex "html,7" "" "" "\def\directbuild{}
```

To make table of contents in HTML have more spaces and look better, use this in the .cfg file:

```
\begin{document}
\ConfigureToc{section}
  {\tocNesting{1}\HCode{<li>}}{ }{ } { }
\ConfigureToc{subsection}
  {\tocNesting{2}\HCode{<li>}}{ }{ } { }
\ConfigureToc{subsubsection}
  {\tocNesting{3}\HCode{<li>}}{ }{ } { }
\Configure{tableofcontents}
  {} {\tocNesting{0}} {} {} {}

\newcount\c
\def\tocNesting#1{%
  \expandafter\ifx \csname level#1\endcsname\relax
    \ifnum #1>0 \HCode{<ul>}\fi
    \expandafter\def \csname level#1\endcsname{\HCode{</ul>}}
  \fi
  \c=#1 \advance\c by 1
  \loop
    \csname level\the\c\endcsname
    \expandafter\let \csname level\the\c\endcsname\relax
    \advance\c by 1
  \ifnum \c<10 \repeat
}
```

The above will go in the cfg file. This makes the HTML table of content much nicer.

4.18 How to change magnification factor when using dvisvgm with make4ht?

When using the command

```
make4ht -ulm default -e ~/new.mk4 -c ~/nma.cfg -f html5+dvisvgm_hashes filename.tex "htm,0,p
```

Then make4ht defaults to using these options `dvisvgm -v4 -n --exact -c 1.15,1.15`

These options are set in this file `/usr/local/texlive/2018/texmf-dist/scripts/make4ht/extension`

To change them, add this to your `.mk4` file (Thanks to Michal for this hint)

```
filter_settings "dvisvgm_hashes" {
  options = "-n --exact -c 1.5,1.5"
}
```

4.19 using multicol package in htlatex?

update: 8/10/2013. This below is no longer needed. `htlatex` now includes support directly for multicol. I kept this below for archive purpose, do not use. See this instead

<http://tug.org/pipermail/tex4ht/2013q3/000847.html>

4.19.1 old method to use multicol

see <http://tug.org/pipermail/tex4ht/2013q3/000828.html>

Using this `my.cfg.txt` file as an example

```
\Preamble{ext=htm,pic-align}

\begin{document}
\EndPreamble

\catcode`\:=11 \catcode`\@=11

\Configure{HtmlPar}
  {\EndP\HCode{<!--l. \the\inputlineno-->%
<p \csname a:!P\endcsname
      class="no\ifHCond par\else indent\fi" \a:LRdir>}}
```

```

{\EndP\HCode{<!--1. \the\inputlineno-->%
<p \csname a:!P\endcsname
      class="\ifdim \parindent=\z@ no\fi indent" \a:LRdir>}}
{{\Tg</p>}}
{{\Tg</p>}}%

\renewenvironment{multicols}[1]{\IgnorePar\EndP%
\HCode{<div class="newspaper"#1\HCode{">}
\expandafter\ifx\csname .newspaper#1\endcsname\relax%
\Css{.newspaper#1 p:first-child { margin-top: 0em; }}
\Css{.newspaper#1 {
  -moz-column-count:#1; /* Firefox */
  -webkit-column-count:#1; /* Safari and Chrome */
  column-count:#1;
  -moz-column-gap:10px; /* Firefox */
  -webkit-column-gap:10px; /* Safari and Chrome */
  column-gap:10px;
  -moz-column-rule:1px outset \#F8F8F8 ; /* Firefox */
  -webkit-column-rule:1px outset \#000000; /* Safari and Chrome */
  column-rule:1px outset \#000000;
}}
\expandafter\gdef\csname .newspaper#1\endcsname{1}%
\fi%
\ShowPar\par}
{\EndP\HCode{</div>}}

\ConfigureEnv{multicols}
  {\par\IgnorePar\EndP%
   \gHAdvance\MultiCols by 1\relax}
  {\ifvmode\IgnorePar\fi\EndP}
  {}{}

\endinput

```

and using this Latex file as an example foo.tex

```

\documentclass{article}%
\usepackage{lipsum}
\usepackage{multicol}
\setlength{\columnsep}{20pt}

```

```
\setlength{\columnseprule}{0.01pt}
\begin{document}

\begin{multicols}{2}

  \begin{enumerate}
    \item A
    \item B
  \end{enumerate}
  \lipsum[1-10]

\end{multicols}

\end{document}
```

and using this command `htlatex foo.tex "my.cfg"` then `htlatex` will generate multiple columns.

Thanks goes to Jagath AR for help in greatly improving the configuration file.

4.20 How to use images with `htlatex` and `pdflatex`

This is what I do. Here is an template example

```
\documentclass[12pt,notitlepage]{article}

\usepackage{graphicx}
\begin{document}
\includegraphics[scale=0.4]{img}
\end{document}
```

I have `img.png` to start with, since most apps I use can generate `.png` images. But since `htlatex` wants `.eps`, I convert the `png` to `eps` like this

```
convert img.png eps3:img.eps
```

Make sure to use `level3 eps` to reduce the size. Note, no space between `eps3:` and the target file name next to it. Have to use `eps` for `htlatex`, else it will not scale the `png` file. `htlatex` can read `png` files, but `png` files have no bounding boxes, so can't change the size if needed as in the above example.

What if you do not have png image as the original? and only have eps? Then now pdf_latex is not happy and ht_latex is happy. Ok, no problem, use this package as below. So this solution below will work for all conditions

```
\documentclass[12pt,notitlepage]{article}
\usepackage{epstopdf}%
\epstopdfsetup{update}

\usepackage{graphicx}
\begin{document}
\includegraphics[scale=0.4]{img}
\end{document}
```

So what will happen now, is if the file was `img.eps`, then pdf_latex will convert it to pdf automatically and use the `img.pdf` file for the graphics. ht_latex see the eps file and is happy.

So rule of thumb: If it was `img.png`, convert to eps first to make ht_latex happy. If it was `.eps`, then include the above packages to make pdf_latex happy. And always leave the extension off the image name in the latex file as above.

It will be better to generate `.eps` image to start with from the app which created the images if possible, so do not have to remember to convert them each time to eps, But if not, do the above.

4.21 adding white space

tex4ht does not support `\quad` or `\qquad` out of the box, as it generates normal spaces in HTML for these which will be collapsed to single space. Replace this by something such as `\hspace{5mm}`

Another work around is found here

<http://comments.gmane.org/gmane.comp.tex.tex4ht/86>

4.22 Avoid vref

Watch out. Do not use `\vref`, and replace with `\ ref`. Using `\vref` caused me many hours trying to find out why the document was cut off in HTML. Tex4ht does not work with `\vref` and will cause many problems. As of texlive 2014

4.23 Where are the 4ht files located?

They are in `/usr/local/texlive/2014/texmf-dist/tex/generic/tex4ht/*.4ht`

4.24 Where is tex4ht.env located ?

This file is in `/usr/local/texlive/2014/texmf-dist/tex4ht/base/unix/tex4ht.env`

4.25 Patch for report style

added August 10, 2014

There is a bug in tex4ht as of texlive 2014. When using report style the table of content shows section even if told not to.

Use the patch shown in this link. Edit your report.4ht by the patch shown here

The report.4ht file is located in

`/usr/local/texlive/2014/texmf-dist/tex/generic/tex4ht/report.4ht`

This is until the fix is added to texlive.

Note: The above only work if the HTML page is not split. If you are splitting it, then the bug is stil there and not fixed.

4.26 Watch out for Verbatim frame not showing in Chrome

added August 14, 2014

To add frame around Verbatim, the `framerule` must be used to force the frame thickness to be at least 0.8pt else it will not show in Chrome. (Thanks for Michal Hoftich for finding why the frame was not showing in Chrome).

So to use a frame and having it show in all three major browsers, use something as follows (until Chrome can handle all rule thickness).

```
\documentclass[12pt]{article}
\usepackage{fancyvrb}
\begin{document}

\begin{Verbatim}[frame=single,framerule=.8pt]
text
\end{Verbatim}
\end{document}
```

4.27 How to use tex4ht with SVG for math and images

This is the best configuration to use. It makes the math use .svg for images instead of png, and also supports an includes pictures as svg.

First thing is to edit `tex4ht.env`

```
sudo vi /usr/local/texlive/2014/texmf-dist/tex4ht/base/unix/tex4ht.env
```

```

<dvipng>
G.png
Gdvipng -T tight -x 1400 -D 110 -bg Transparent -pp %%2:%%2 %%1 -o %%3
G.gif
Gdvipng -T tight -x 1400 -D 110 -bg Transparent -gif -pp %%2:%%2 %%1 -o %%3
G.
%echo "dbg: got to dvi to png via dvipng"
Gdvipng -T tight -x 1400 -D 72 -bg Transparent -pp %%2:%%2 %%1 -o %%3
%----- let's not use convert, to simplify mactex.
% G.
% Gdvips -Ppdf -mode ibmvga -D 110 -f %%1 -pp %%2 > zz%%4.ps
% Gconvert -crop 0x0 -density 110x110 -transparent '#FFFFFF' zz%%4.ps %%3
% Grm zz%%4.ps
G.svg
Gdvisvgm -n -p %%2 -c 1.2,1.2 -s %%1 > %%3
</dvipng>

```

Add in these 2 lines above.
There were not there before

The next step is to edit your .cfg and make it like this

```

\Preamble{ext=htm,charset="utf-8",p-width,pic-align}
\Configure{VERSION}{ }
\Configure{DOCTYPE}{\HCode{<!DOCTYPE html>\Hnewline}}
\Configure{HTML}{\HCode{<html>\Hnewline}}{\HCode{\Hnewline</html>}}
\Configure{@HEAD}{ }
\Configure{@HEAD}{\HCode{<meta charset="utf-8"/>\Hnewline}}
\Configure{@HEAD}{\HCode{<meta name="generator" content="TeX4ht
(http://www.cse.ohio-state.edu/~string~gurari/TeX4ht/) " />\Hnewline}}
\Configure{@HEAD}{\HCode{<link rel="stylesheet" type="text/css"
href="\expandafter\csname aa:CssFile\endcsname" />\Hnewline}}

\Configure{Picture}{.svg}

\makeatletter
\Configure{graphics*}
{svg}
{
  {\Configure{Needs}{File: \Gin@base.svg}\Needs{}}
  \Picture[\csname a:GraphicsAlt\endcsname]{\csname Gin@base\endcsname.svg
    \csname a:Gin-dim\endcsname}
}
%
```

```

\makeatletter
\Configure{graphics*}
{eps}%
{\Needs{"convert \csname Gin@base\endcsname.eps
          \csname Gin@base\endcsname.png"}%
  \Picture[pict]{\csname Gin@base\endcsname.png}%
  \special{t4ht+@File: \csname Gin@base\endcsname.png}
}

\begin{document}
\EndPreamble

```

Now compile your .tex file like this (where nma.cfg below is your tex4eht .cfg file.)

```
make4ht index.tex "nma,htm,pic-align,charset=utf-8,notoc*" " -cunihtf -utf8"
```

Make sure to include `\usepackage{graphicx}` in your latex document! else you'll get this error

```

(/usr/local/texlive/2014/texmf-dist/tex/generic/tex4ht/html4-math.4ht)
1.34 --- TeX4ht warning --- \Configure{graphics*}? ---

! LaTeX Error: Missing \begin{document} in `nma.cfg'.

```

Thanks goes to Michal-h21 for help in making the above instructions.

4.28 converting cropped pdf page to svg

After cropping part of pdf page and generating foo.pdf file, which is one page only, to convert this to svg file to include with tex4ht, do this

```
pdf2svg p.pdf p.svg
```

I found this works better than

```
inkscape --without-gui --file=p.pdf --export-plain-svg=p.svg
```

This can be used to do the conversion of all cropped pdf files in the folder

```
#!/bin/bash
for file in *.pdf; do
```

```
filename=${file%.*}
pdf2svg "$filename.pdf" "$filename.svg"
done
```

4.29 How to change image size of svg for html generation?

I can't find out why `\includegraphics[scale=0.5]{pic.svg}` does not work with tex4ht as it does with pdf. So to change the svg image size, simply edit the svg file with text editor, and change the first line that says something like `width="500pt" height="500pt"` to just `width="250px"` for example, and save the .svg file.

4.30 How to include animated gif file in the HTML?

add this in Latex file, and use normal HTML coding in there. This will only show up in the HTML and not affect the pdflatex run

```
\ifdefined\HCode
\HCode{
  <image src="movie.gif" alt="movie"
}
```

4.31 How to build using make4ht

This is what I use now to build things for tex4ht

```
make4ht -u -c ~/nma.cfg -e ~/main.mk4 index.tex "htm,pic-align,notoc"
```

To split the document, say 3 levels, then the command is

```
make4ht -u -c ~/nma.cfg -e ~/main.mk4 index.tex "htm,3,pic-align,notoc"
```

Make sure to have the main.mk4 build file in my home folder as well as the .cfg file. The main.mk4 I use now is written by michal.h21 main.mk4 and my .cfg is nma.cfg

You need to have latest `make4ht` installed, which does not come with `texlive`. You can get it from <https://github.com/michal-h21/make4ht>

see `how-to-speed-up-tex4ht-image-generation-process` for reference

Thanks to `michal.h21` support for making the above possible.

4.32 remember to set `TEXINPUTS`

`htlatex` uses `TEXINPUTS` to find `.cfg` file if the file is not in the current directly. This is what I do. Edit `$HOME/.bashrc` and add the line `export TEXINPUTS=.:$HOME:$TEXINPUTS`

4.33 To make `.bbx` files

use `ebb -x foo.pdf` if you get an error like this

```
* WARNING ** Streams with DecodeParams not supported.
```

This convert the pdf to ps, then convert it back to pdf, it should now work

```
pdf2ps foo.pdf foo.ps
ps2pdf foo.ps foo.pdf
ebb -x foo.pdf
```

4.34 How to used fixed width table?

`tex4ht` does not support fixed width using the `m{}` option in `tabular`. So this will not work

```
\begin{tabular}{|m{2in}|m{2in}|m{2in}|}\hline
```

The width is ignored, even if one compiles with `p-width` option. One way is to change `m` to `p`. Another option is to look at this post

4.35 tex4ht references

1. CVR web site, has lots of tex4ht information <http://cvr.cc/?p=504>
2. main tex4ht page <http://tug.org/applications/tex4ht/mn.html>
3. <http://tug.org/applications/tex4ht/mn3.html>
4. <http://www.cvr.cc/?p=362>
5. configure command
6. tex4ht options by CVR <http://www.cvr.cc/?p=504>
7. <http://tug.org/applications/tex4ht/mn14.html#mn14-1>
8. <http://newsgroups.derkeiler.com/Archive/Comp/comp.text.tex/2010-07/msg00585.html>
9. thread at <http://tug.org/pipermail/tex4ht/2013q3/000856.html>
10. commits to tex4ht source tree <http://tug.org/pipermail/tex4ht-commits/>
11. Michal-h21 tex4ht tutorial <https://github.com/michal-h21/helpers4ht/wiki/tex4ht-tutorial>
12. Tex4ht for SW <http://facweb.knowlton.ohio-state.edu/pviton/support/swpht.html#swphtpa4.html>
13. <http://tex.stackexchange.com/questions/69063/tex4ht-includegraphi> cspage-10foo-pdf shows how to include pdf pages in HTML. But I could not get it to work in Tl 2015.

CHAPTER 5

TIKZ NOTES

5.1 Simple tikz examples

Simple tikz examples

5.2 Generate SVG from tikz drawing

see page 117 in tikz manual 3.0

```
% example.tex
\documentclass[dvisvgm]{minimal}

\usepackage{tikz}

\begin{document}
Hello \tikz [baseline] \fill [fill=blue!80!black] (0,.75ex) circle[radius=.75ex];
\end{document}
```

And then run

```
latex example
dvisvgm example
```

or better

```
lualatex --output-format=dvi example
dvisvgm example
```

5.3 misc. notes

1. tikz uses cm by default. a standard page in the US (letter) is 21.5 cm wide and 27.8 cm high.

5.4 How to include pdf file using tikz picture

```
\documentclass[11pt]{report}
\usepackage{amsmath,mathtools}
\usepackage{graphicx}
\usepackage{pdfpages}
\usepackage{tikz}
\usepackage{pgffor}

\begin{document}
\pdfximage{file2.pdf}
\foreach \index in {1,...,\the\pdflastximagepages}
{
  \begin{tikzpicture}[remember picture]
    \node[inner sep=0pt] at (current page.center)
      {\includegraphics[page=\index]{file2.pdf}};
  \end{tikzpicture}
}
\end{document}
```

5.5 Tikz documentation links

1. tikz manual <http://www.ctan.org/tex-archive/graphics/pgf/base/doc/generic/pgf/>
2. tikz-qtrees <http://www.ctan.org/pkg/tikz-qtrees>
3. tikz-forest <http://www.ctan.org/pkg/forest>
4. example qtrees <http://www.wiki-prog.org/wiki/LaTeX:Arbre>
5. left and right trees <http://tex.stackexchange.com/questions/44970/how-to-specify-left-and-right-node-of-a-tikz-qtrees>
6. simple example of qtrees with node <http://tex.stackexchange.com/question>

s/43924/is-there-a-library-for-drawing-object-inheritance-trees-in-tikz

5.6 making loops

from <http://pgf-and-tikz.10981.n7.nabble.com/Draw-a-shape-use-it-many-times-td4323.html>

```
\documentclass{article}
\input{commonlatex}
\usepackage{tikz}
\newcommand{\MyChair}{
\draw[fill=blue!15,thick] plot coordinates
{(-2,-1)(-2,1)(-1,2)(2,3)(3,2)(3,-2)(2,-3)(-1,-2)};
\draw[fill=blue!15,thick] plot coordinates
{(-2.5,-1)(-2.5,1)(-3.25,2)(-3.25,-2)};
}
\begin{document}
\begin{tikzpicture} [scale=0.125,smooth cycle]
  \foreach \row in {1,2,...,10}
  {
    \foreach \col in {1,2,...,4}
    {
      \begin{scope}[xshift=\row cm,yshift=\col 10 cm]
        \MyChair
      \end{scope}
    }
  }
\end{tikzpicture}
\end{document}
```

5.7 How to make aligned math inside a node?

see <http://tex.stackexchange.com/questions/1342/aligned-equations-inside-of-tikz-node>

5.8 trees with tikz?

1. examples <http://mvngu.wordpress.com/2011/03/31/typeset-trees-using-tikzpgf/>

5.9 more tikz examples

```

\documentclass{standalone}
\usepackage{tikz}
\usepackage{tikz-qtree}
\begin{document}

\tikzset{font=\small}

\begin{tikzpicture}
  \Tree [.A
        [. \node(B){B}; ]
        [. \node(C){C}; ]
      ]
  \begin{scope}[xshift=0in,yshift=-2cm]
    \Tree [. \node(Dx){D};
          [.E ]
          [.F ]
        ]
  \end{scope}
\end{tikzpicture}

\draw[-] (B) -- (Dx);
\draw[-] (C) -- (Dx);
\end{tikzpicture}
\end{document}

```

PDF

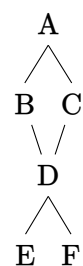

```

\documentclass{standalone}
\usepackage{tikz}
\begin{document}
\begin{tikzpicture}

\draw [<->] (3,0) -- (0,0) -- (0,3);
\draw (0,0) rectangle (3,3);
\draw [fill=lightgray] (0,2.8)--(0,0)--(2.8,0);
\node [font=\Huge] at (2,2) {$0$};

\end{tikzpicture}
\end{document}

```

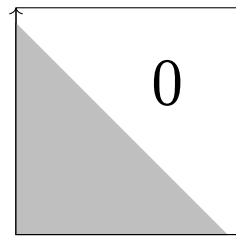

```

\documentclass{standalone}
\usepackage{tikz}
\begin{document}
\begin{tikzpicture}

\draw [very thin] (1,1) rectangle (2,2);
\draw [<->] (3,0) -- (0,0) -- (0,3);

\end{tikzpicture}
\end{document}

```

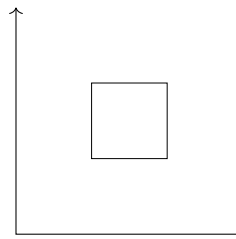

```

\documentclass{standalone}
\usepackage{tikz}
\begin{document}
\begin{tikzpicture}

\draw [<->] (3,0) -- (0,0) -- (0,3);
\draw [very thin] (1,1) rectangle (2,2);
\draw [fill=lightgray] (1,1)--(1.5,1)--(1,1.5);

\end{tikzpicture}
\end{document}

```

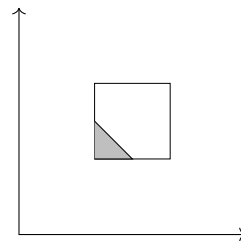

```



\documentclass{standalone}
\usepackage{tikz}
\begin{document}
\begin{tikzpicture}

\def\x{0}%
\def\y{0}%
\draw [very thin] (\x,\y) rectangle (\x+2,\x+2);
\draw [fill=lightgray] (\x,\y)--(\x+1.75,\y+0)--(\x+0,\y+1.75);
\node[font=\Huge] at (\x+1.25,\y+1.25) {$0$};
\node at (\x+2.25,\y+1) {$+$};

\end{tikzpicture}
\end{document}

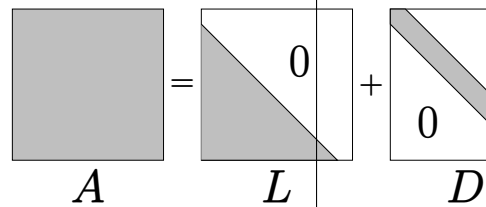
```

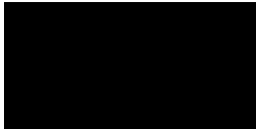

<pre> \documentclass{standalone} \usepackage{tikz} \begin{document} \begin{tikzpicture} \path[draw] (0,0) rectangle (2,1); \end{tikzpicture} \end{document} </pre>	PDF	
<pre> \documentclass{standalone} \usepackage{tikz} \begin{document} \begin{tikzpicture} \path[fill,draw] (0,0) rectangle (2,1); \end{tikzpicture} \end{document} </pre>	PDF	
<pre> \documentclass{standalone} \usepackage{tikz} \begin{document} \begin{tikzpicture} \path[shade,draw] (0,0) rectangle (2,1); \end{tikzpicture} \end{document} </pre>	PDF	
<pre> \documentclass{standalone} \usepackage{tikz} \begin{document} \begin{tikzpicture} \path[shade,top color=yellow!80!black, bottom color=white,draw] (0,0) rectangle (2,1); \end{tikzpicture} \end{document} </pre>	PDF	

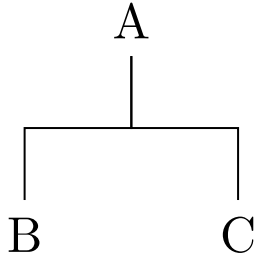
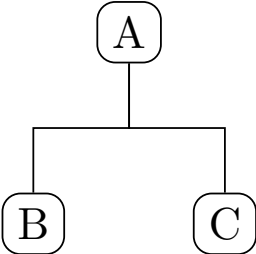
<pre> \documentclass{standalone} \usepackage{tikz} \usetikzlibrary{trees} \begin{document} \begin{tikzpicture} \node {A} [edge from parent fork down] child {node {B}} child {node {C}} ; \end{tikzpicture} \end{document} </pre>	PDF	
<pre> \documentclass{standalone} \usepackage{tikz} \usetikzlibrary{trees} \begin{document} \tikzset{every node/.style={draw, rectangle, rounded corners } } \begin{tikzpicture} \node {A} [edge from parent fork down] child {node {B}} child {node {C}} ; \end{tikzpicture} \end{document} </pre>	PDF	

```
\documentclass{standalone}
\usepackage{tikz}
\usetikzlibrary{trees}
\begin{document}

\tikzset{level 1/.style={sibling distance=2cm},
         level 2/.style={sibling distance=1cm}}

\begin{tikzpicture}
  \node {A}
    [edge from parent fork down]
    child {node {B}
      child {node {B1}}
    }
    child {node {C}
      child {node {C1}}
      child {node {C2}}
      child {node {C3}}
    }
  ;
\end{tikzpicture}
\end{document}
```

PDF

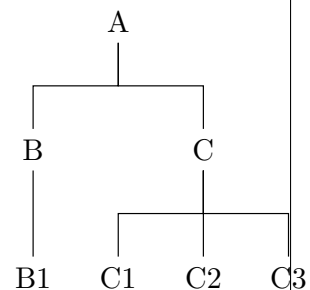

see <http://tex.stackexchange.com/questions/124862/how-to-draw-a-diagram-that-forks-out-then-joins-in-the-middle-then-forks-out-again>

```

%written by Qrrbrbirlbel at Tex stackexchange
\documentclass[tikz]{standalone}
\usetikzlibrary{positioning-plus,paths.ortho}
\tikzset{
  parents/.style 2 args={
    @parents/.style={insert path={edge[edge from children path] (#1-##1)}},
    @parents/.list={#2}},
  edge from parent path={
    (\tikzparentnode\tikzparentanchor) |-| (\tikzchildnode\tikzchildanchor)},
  edge from children path/.style={
    to path={
      (\tikztostart\tikzchildanchor) |-| (\tikztotarget\tikzparentanchor) \tikzttonodes}}
}
\begin{document}
\begin{tikzpicture}[
  node distance=\tikzleveldistance and \tikzsiblingdistance,
  on grid,
  text depth=+0pt,
  hvvh=from center
]

\node (A) {A}
  child {node {B}}
  child {node {C}};
\node[below=2:of A] (E) {E} [parents={A}{1,2}]
  [sibling distance/.expanded=2*\the\tikzsiblingdistance]
  child {node {F}}
    child {coordinate
      [anchor=center,sibling distance/.expanded=.5*\the\tikzsiblingdistance]
      child {node {N}}
      child {node {Q}}
    }
  child {node {R}}
}

```

PDF

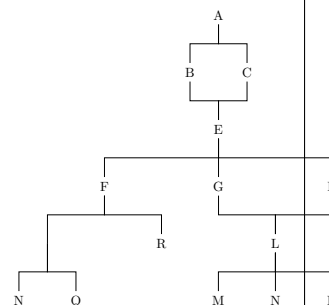

CHAPTER 6

USING SCIENTIFIC WORD

6.1 location of external package in Scientific word

if using SW on windows and want to add a package not included by SW, then first download it from CTAN and put the .sty file here

C:\swp55\TCITeX\TeX\LaTeX\contrib

and from inside SW, follow instructions as given here

<http://www.mackichan.com/index.html?techtalk/455.htm> mainFrame

Note Be careful to enter commands correctly. Incorrect syntax can cause LaTeX to fail and may damage your document permanently.

1. On the Typeset toolbar, click the Options and Packages button  or, from the **Typeset** menu, choose **Options and Packages**.
2. Choose the **Package Options** tab and choose **Go Native**.
3. In the **Native LaTeX Packages** dialog, enter the name of the package you want, enclosed in curly braces.

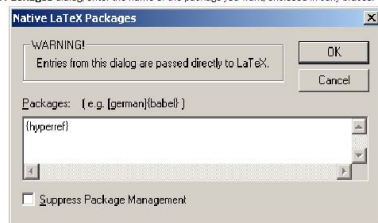

or you can simply edit the preamble and add `\usepackage{packageName}`

6.2 inputting Latex files into SW document

This is tricky. But just do this and do not follow any other instructions given in other places, they are all very confusing. Here is the deal.

When you write `input{file.txt}` in SW document `main.tex`, then it will not find `file.txt` because SW process `main.tex` is some other temporary folder. The easiest way to do this, is to make `main.tex` as a master document, then it will use the current folder.

To make `main.tex` as master document, create a file called `empty.tex` in the same folder and type in it exactly the following (using a text editor)

```
%TCIDATA{LaTeXparent=0,0,main.tex}
```

That is all, the one line above. Now go back to `main.tex`, and open that in a text editor (not in SW) and go to the end of the file just before end of the document, and add these lines, including the comments! this is important.

```
%TCIMACRO{\QSubDoc{Include empty}{\input{empty.tex}}}%  
%BeginExpansion  
\input{empty.tex}%  
%EndExpansion
```

Now, close everything. Now `main.tex` is a master document. Now you can write `\input{file.txt}` in `master.tex` and SW will now include the `file.txt` (assuming of course the file is in the same folder as `master.tex`).

So, for each latex file that is meant to include input files, we must have an `empty.tex` file there, and add it at the bottom of the document itself as shown above.

6.3 Adding Latex code into SW so that SW do not touch it

sometimes I have a need to insert Latex code into the `.tex` file while using SW, but do not want SW to look at this code. This is code used by `htlatex` for example. One way to do that is by using encapsulated tex field. This field can be added either from the SW GUI, or directly in source code. To add it in source, let assume we want to add `\ifdefined\HCode\href{../..../index.htm}{up}` in the Latex source file. Then write

```
%  
%TCIMACRO{\TeXButton{TeX field}  
%{ \ifdefined\HCode\href{../../index.htm}{up}  }  
%}  
%BeginExpansion  
  \ifdefined\HCode\href{../../index.htm}{up}  
%EndExpansion
```

Notice what we did. The code has to be put in 2 places. In the comment and inside the `BeginExpansion` and `%EndExpansion` block.

That is the only reliable way to insert Latex code for use by `tex` or `tex4ht` without having `SW` see it. Otherwise, `SW` can change it or move it around, or worst, comment it out. Now, the above can be processed OK by `htlatex`, since the `TeXField` is a comment, but the code is still there in the second block.

6.4 Fixing decoration fbox

When adding a frame in `SW`, around math equation such as displayed formula, it will add `\fbox` to do it. To improve how the math looks inside, added this to the preamble of the document

```
\usepackage{amsmath}  
  
\let\latexfbox\fbox  
\renewcommand{\fbox}[1]{%  
  \latexfbox{\everymath{\displaystyle}#1}%  
}
```

Thanks for <http://tex.stackexchange.com/>

CHAPTER 7

TRYING LATEXML

To obtain Latexml use <http://dlmf.nist.gov/LaTeXML/> (gone) use instead <https://github.com/bruce miller/latexml> for current repository.

see <https://www.arxiv-vanity.com/> for a web page which uses latexml to convert papers to html

See <http://latexml.mathweb.org/editor?demo=xii> to convert document on the fly to html. past code on the left side.

see <http://jblevins.org/log/xml-tools> for how to install and use latexml. And an online convertor

for binding see <http://trac.mathweb.org/LaTeXML/browser/trunk/lib/LaTeXML/Package> (gone)

See <http://www.albany.edu/~hammond/demos/Html5/arXiv/lxmlexamples.html> for examples of Math papers translated to HTML using Latexml (gone).

CHAPTER 8

TRYING PDF2HTML EX

On windows, installed the binaries. Then to convert a pdf to HTML do, from a DOS window:

```
>pdf2htmlEX --data-dir C:\pdf2htmlEX\data --dest-dir HTML
--process-outline 1 --fallback 1 --bg-format svg --zoom 1
--process-type3 1 report.pdf
```

The above converts report.pdf to report.html and puts the HTML in the HTML subfolder. The folder C:\pdf2htmlEX\data is where the manifest data is, which is included when installing the application.

The windows version is [here](#).

See [This](#) for more information about pdf2htmlEX