

University Course

**ME 240
Dynamics**

**University of Wisconsin, Madison
Fall 2017**

My Class Notes

Nasser M. Abbasi

Fall 2017

Contents

1	Introduction	1
1.1	syllabus	2
2	study notes	5
2.1	Solving pendulum example, lecture Nov 30l 2017	6
2.2	Solving example 7.8, Textbook, page 554, using graphical method	9
2.3	cheat sheets	11
3	Discussions	15
3.1	week 14, my solution to first problem	16
3.2	week 10	17
3.3	week 11 NOV 12 to NOV 18	20
4	Exams	23
4.1	First exam	24
4.2	Second exam	31
4.3	Final exam	42
5	practice exams	43
5.1	practice first midterm exams	44
5.2	practice second midterm exams	92
5.3	practice exam for finals	136
6	HWs	159
6.1	HW 1	160
6.2	HW 2	163
6.3	HW 3	169
6.4	HW 4	174
6.5	HW 5	181
6.6	HW 6	187
6.7	HW 7	193
6.8	HW 8	198
6.9	HW 9	206
6.10	HW 10	212
6.11	HW 11	222
6.12	HW 12	229
6.13	HW 13	238
7	Quizzes	247
7.1	Quizz 1	248
7.2	Quizz 2	250
7.3	Quizz 3	251
7.4	Quizz 4	252
7.5	Quizz 5	254
7.6	Quizz 6	256
7.7	Quizz 7	258
7.8	Quizz 8	261
7.9	Quizz 9	264
7.10	Quizz 10	266
7.11	Quizz 11	269

Chapter 1

Introduction

Took this course in fall 2017 to help me remember some dynamics which I forgot. Instructor Dr. Sonny Nimityongskul was one of the best Dynamics teachers I had and explained things very clearly. Class was very large, over 250 students. Course was hard (Dynamics is a hard subject) but was useful also.

Links

1. class canvas site <https://canvas.wisc.edu/courses/57180> requires login.

1.1 syllabus

UNIVERSITY OF WISCONSIN-MADISON
DEPARTMENT OF ENGINEERING PHYSICS
EMA 202 – ME 240: DYNAMICS
Fall 2017

Lectures: Tuesday & Thursday 1:20-2:10pm 1800 Engineering Hall

Textbook: Engineering Mechanics – Dynamics, Gray/Costanzo/Plesha (2nd Edition) + Connect Plus Access Card, McGraw-Hill

Prerequisites: EMA 201 (Statics) and Math 222 (Calculus 2)

Instructor: Dr. Sonny Nimityongskul 509 ERB, apnimityongs@wisc.edu

Office Hours: Thursday 11:00-12:00, 509 ERB

Teaching Assistants:

Instructor	Email
Jenna Thorp	jlynne@wisc.edu
Shu Wang	swang597@wisc.edu
Guannan Guo	gguo7@wisc.edu
AJ Gross	ajgross2@wisc.edu
Peter Grimmer	pgrimmer@wisc.edu
Aaron Wright	ahwright3@wisc.edu

Discussion Sections:

EMA 202	Time	Room	TA
Section 301	8:50 am	3418 EH	Peter Grimmer
Section 302	9:55 am	3418 EH	Peter Grimmer
Section 303	11:00 am	3418 EH	Peter Grimmer
Section 304	12:05 pm	2540 EH	Aaron Wright
Section 305	1:20 pm	3418 EH	Aaron Wright
Section 306	2:25 pm	3418 EH	AJ Gross
Section 307	12:05 pm	1209 EH	Shu Wang

ME 240	Time	Room	TA
Section 301	8:50 am	2108 ME	AJ Gross
Section 302	9:55 am	2108 ME	Shu Wang
Section 303	11:00 am	2108 ME	Jenna Thorp
Section 304	12:05 pm	2108 ME	Jenna Thorp
Section 305	1:20 pm	2108 ME	Guannan Guo
Section 306	2:25 pm	2108 ME	Guannan Guo

Office Hours: Location 2355 Engineering Hall

Monday	4-6 pm	Aaron, AJ
Tuesday	5-6 pm	Shu
Wednesday	5-6 pm	Jenna
Thursday	5-6 pm	Guannan

Walk-In Tutoring (Undergrads): Typically Sunday through Thursday 6:30-9:00pm on the 3rd floor of Wendt Library. Open to all.

PrEPs labs and tables: Supplemental instruction provided by the College of Engineering. Enrollment in InterEGR 150 is required to attend. Three sections are available that meet twice per week. MW 9:30-10:45am, MW 6:30-7:45pm, TR 9:30-10:45am. See <https://www.engr.wisc.edu/academics/student-services/ulc/supplemental-instruction/> for more info.

Course Website: <https://canvas.wisc.edu/courses/57180> Note that this is the site for ME 240. Those of you enrolled in EMA 202 should also have access to the ME 240 webpage. The canvas page for EMA 202 will not be used for this course.

Homework: Through McGraw-Hill Connect at: <http://connect.mheducation.com/class/s-nimityongskul-fall-2017-dynamics-ema-202-me-240> Homework will be assigned each week and is due the following **Monday at 11:55pm. No late homework will be accepted.**

Weekly Quizzes will be given on the course Canvas page. Quiz work must be done independently. You may consult your book and notes during the quiz, but you may not work with anyone else, nor ask for assistance with the quiz. Your lowest quiz grade will be dropped to accommodate unanticipated events.

The quizzes will have 1-2 questions and must be completed within 30 minutes of beginning the quiz. Each quiz will be accessible through Canvas from Tuesday at 2:15pm to Wednesday at 11:55pm.

Midterm Exams: Monday Oct. 23rd and Tuesday Nov. 21st. You may choose to take the midterm exams in either of two time slots, **5:30-7:00 PM or 7:30-9 PM**, but you **must** take the midterm during one of those times, due to the large enrollment in the course.

Final Exam: Monday December 18th at 10:05am No alternate times are available.

Weighting:	Midterm Exams (2)	25% each
	Final Exam	25%
	Textbook HW (Connect)	10%
	Weekly Quizzes	10%
	Discussion Section Participation	5%

Grading: Course grading will follow the scale A 92.0 – 100 %, AB 87.0 – 91.9 %, B 82.0 – 86.9 %, BC 77.0 – 81.9 %, C 72.0 – 76.9 %, D 62.0 – 71.9 %, F < 62.0 % unless otherwise announced (e.g., an exam may be curved if an adjustment is warranted).

McBurney: If you have McBurney accommodations regarding exams, notify Dr. Nimityongskul during the first two weeks of the semester, the sooner the better. If you arrange accommodations after that time, notify instructor as soon as possible.

EMA 202 / ME 240 Schedule Fall 2017

	Date	Mtg	Text Sec	HW Problems, Notes
T	9/5	1		No class
R	9/7	2	2.1	HW1: { 2.6, 2.19
T	9/12	3	2.2	2.66, 2.77
R	9/14	4	2.3	2.94, 2.99 }
T	9/19	5	2.4 & 2.6	HW2: { 2.127, 2.128, 2.182, 2.191
R	9/21	6	2.5	2.159, 2.172}
T	9/26	7	2.7	HW3: {2.227, 2.241, 2.253
R	9/28	8	3.1	3.25, 3.31, 3.38}
T	10/3	9	3.2	HW4: {3.58, 3.69, 3.74
R	10/5	10	3.3	3.115, 3.116, 3.133}
T	10/10	11	4.1	HW5: { 4.7, 4.20, 4.31
R	10/12	12	4.2	4.39, 4.60, 4.62}
T	10/17	13	4.3	HW6: { 4.73, 4.81, 4.87
R	10/19	14	4.4 & Review	4.104, 4.109, 4.111}
M	10/23		Exam 1	chapter 2-4
T	10/24	15	5.1	HW7: { 5.12, 5.26, 5.31
R	10/26	16	5.2	5.66, 5.70, 5.80}
T	10/31	17	5.2-5.3	HW8: {5.94, 5.99, 5.117
R	11/2	18	5.3	5.125, 5.128, 5.133}
T	11/7	19	6.1	HW9: {6.7, 6.22, 6.35
R	11/9	20	6.2	6.40, 6.42, 6.58}
T	11/14	21	6.2	HW10: {6.60, 6.65, 6.74
R	11/16	22	6.3	6.112, 6.124, 6.128}
T	11/21	23	Review	Exam 2 in evening, chapter 5-6
R	11/23	24	THANKSGIVING (No discussions Wednesday or Friday)	
T	11/28	25	7.1-7.2	HW11: { 7.5, 7.7, 7.19
R	11/30	26	7.3	7.29, 7.42, 7.52}
T	12/5	27	7.4	HW12: {7.61, 7.77, 7.91
R	12/7	28	8.1	8.6, 8.25, 8.40}
T	12/12	29	8.2	HW13: {8.54, 8.88, 8.91, 8.105, 8.107, 8.110}
R	12/14			No class
M	12/18	Final Exam	10:05am	chapters 7 & 8

Chapter 2

study notes

Local contents

2.1	Solving pendulum example, lecture Nov 30l 2017	6
2.2	Solving example 7.8, Textbook, page 554, using graphical method	9
2.3	cheat sheets	11

2.1 Solving pendulum example, lecture Nov 30 2017

2.1.1 Problem 1

Example 2: The pendulum consists of a $m_R = 10$ kg uniform slender rod and a sphere of mass $m_S = 15$ kg. If the pendulum is subjected to a moment of $M = 50$ N·m, and has an angular velocity of $\omega = 3$ rad/s when $\theta = 45^\circ$, determine the reaction force from pin O

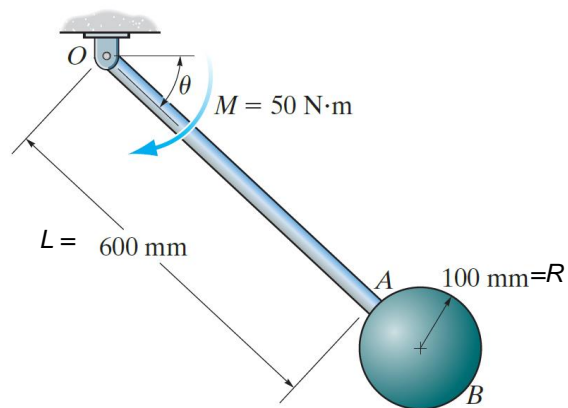

The FBD and inertia diagram is

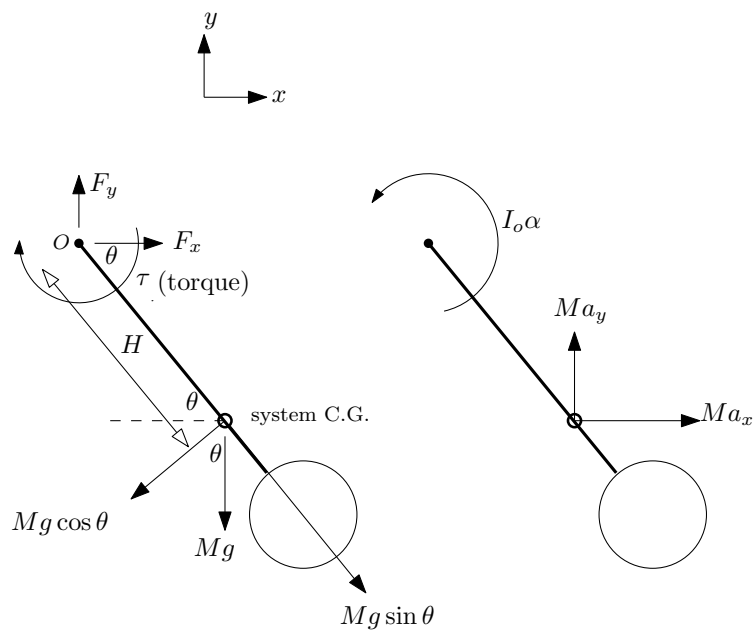

fbd.ipe, Nasser M. Abbasi, Dec 1, 2017. ME 240 dynamics

Where $M = m_{\text{disk}} + m_{\text{bar}}$ and H is location of system center of mass. Total mass is $M = 15 + 10 = 25$ kg.

$$\begin{aligned}
 H &= \frac{m_{\text{sphere}}(L + R) + m_{\text{rod}}\left(\frac{L}{2}\right)}{m_{\text{sphere}} + m_{\text{rod}}} \\
 &= \frac{15(0.6 + 0.1) + 10(0.3)}{15 + 10} \\
 &= 0.54 \text{ m}
 \end{aligned}$$

And

$$\begin{aligned}
 I_o &= I_{\text{sphere}_o} + I_{\text{bar}_o} \\
 &= \left(\frac{2}{5} m_{\text{sphere}} R^2 + m_{\text{sphere}} (L + R)^2 \right) + \frac{1}{3} m_{\text{bar}} L^2 \\
 &= \left(\frac{2(15)(0.1)^2}{5} + 15(0.6 + 0.1)^2 \right) + \frac{1}{3} (10)(0.6)^2 \\
 &= 8.61 \text{ kg}\cdot\text{m}^2
 \end{aligned}$$

From FBD we obtain 3 equations.

$$\begin{aligned}
 F_x &= M a_x \\
 F_y - Mg &= M a_y \\
 -\tau - (Mg \cos \theta) H &= I_o \alpha
 \end{aligned}$$

Or

$$\begin{aligned}
 F_x &= 25 a_x \\
 F_y - (25)(9.81) &= 25 a_y \\
 -50 - \left((25)(9.81) \cos \left(45 \left(\frac{\pi}{180} \right) \right) \right) (0.54) &= (8.61) \alpha
 \end{aligned}$$

Or

$$\begin{aligned}
 F_x &= 25 a_x & (1) \\
 F_y - 245.25 &= 25 a_y & (2) \\
 -16.684 &= \alpha & (3)
 \end{aligned}$$

3 equations with 4 unknowns: F_x, F_y, a_x, a_y . But looking at this diagram, which relates a_x, a_y to α .

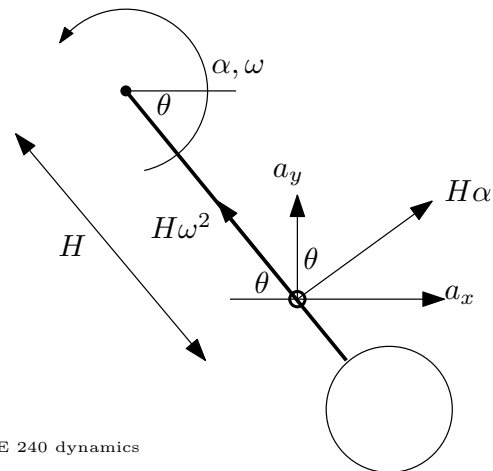

fbd_2.ipe, Nasser M. Abbasi, Dec 1, 2017. ME 240 dynamics

We see that

$$\begin{aligned}
 a_y &= H \omega^2 \sin \theta + H \alpha \cos \theta \\
 &= (0.54)(3)^2 \sin \left(45 \left(\frac{\pi}{180} \right) \right) + (0.54)(-16.684) \cos \left(45 \left(\frac{\pi}{180} \right) \right) \\
 &= -2.934 \text{ m/s}^2
 \end{aligned}$$

And

$$\begin{aligned}
 a_x &= H \alpha \sin \theta - H \omega^2 \cos \theta \\
 &= (0.54)(-16.684) \sin \left(45 \left(\frac{\pi}{180} \right) \right) - (0.54)(3)^2 \cos \left(45 \left(\frac{\pi}{180} \right) \right) \\
 &= -9.807 \text{ m/s}^2
 \end{aligned}$$

Using these in (1,2), we find the reaction forces

$$\begin{aligned}F_x &= 25a_x \\ &= 25(-9.807) \\ &= -245.175 \text{ N}\end{aligned}$$

And

$$\begin{aligned}F_y - 245.25 &= 25a_y \\ F_y - 245.25 &= 25(-2.934) \\ F_y &= 171.9 \text{ N}\end{aligned}$$

Total reaction force is $\sqrt{F_y^2 + F_x^2} = \sqrt{(171.9)^2 + (-245.175)^2} = 299.4334 \text{ N}$

2.2 Solving example 7.8, Textbook, page 554, using graphical method

4 A part of a movie stunt, a long, thin 388 lb platform with the length $L=39$ ft has been rigged across a ravine using two ropes OA and BD. Rope OA of length $d=13.4$ is securely tied to the tree, but rope BD has been tied to a carabiner at D that has not been adequately fastened to the rock face. After everything is set up as shown, the carabiner at D breaks free, and the platform starts to fall. Determine the angular acceleration of the platform and the tension in the rope OA immediately after the rope BD breaks free. The initial value of $\theta=39^\circ$. (25pts)

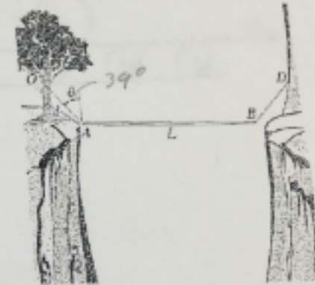

Solve Example 7.8
Textbook, Page 554.
by Nasser Mr. Abbasi

$\Sigma F_x: -T \sin \theta = m a_{Gx}$ (1)
 $\Sigma F_y: T \cos \theta - mg = m a_{Gy}$ (2)
 $M_{cs}: -T \cos \theta \frac{L}{2} = -I_G \alpha_{rod}$ (3)

3 equations: unknowns: $T, \alpha_{rod}, a_{Gx}, a_{Gy}$.
 need extra equations. Looking at point A.

here: $a_{Gy} = -d \alpha_{rope} \sin \theta - \frac{L}{2} \alpha_{rod}$
 $a_{Gx} = -d \alpha_{rope} \cos \theta$

use these in (1), (2) gives

$(1A) \quad -T \sin \theta = m (-d \alpha_{rope} \cos \theta)$
 $(2A) \quad T \cos \theta - mg = m (-d \alpha_{rope} \sin \theta - \frac{L}{2} \alpha_{rod})$
 $(3A) \quad -T \cos \theta \frac{L}{2} = -\frac{1}{12} m L^2 \alpha_{rod}$

3 equations, 3 unknowns
 $T, \alpha_{rope}, \alpha_{rod}$

Physically: $-T \sin 39 = \frac{3.88}{32.2} (- (13.4) \alpha_{rope} \sin 39 - \frac{39}{2} \alpha_{rod})$
 etc. solution is $T = 107.2 \text{ lb force}, \alpha_{rod} = 1.054 \text{ rad/sec}$
 $\alpha_{rope} = -0.5378 \text{ rad/sec}$

2.3 cheat sheets

2.3.1 First exam

Dynamics Equation Sheet – EMA 202 / ME 240 – Spring 2017 (2017/03/14 version)

Disclaimer: This formula sheet is provided for your convenience, and is not guaranteed to include all formulas or expressions needed to solve problems on homework, quizzes, or exams. Students are responsible for all relevant material regardless of its presence or absence on the formula sheet. This sheet will be provided to you with your Midterm Exam and Final Exam. No additional equations or formulas may be brought in written form by the student for either exam.

Geometry:

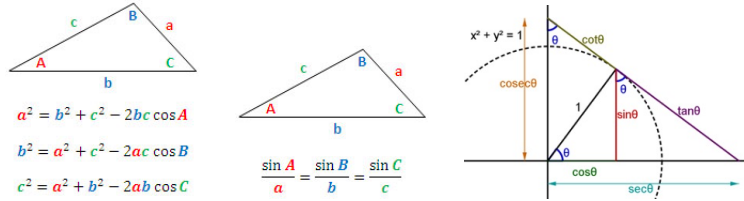

Particle Rectilinear Kinematics:

$$a = \frac{dv}{dt} = \frac{dv}{ds} \frac{ds}{dt} = v \frac{dv}{ds} \quad v = \frac{ds}{dt} \quad a ds = v dv$$

Special case: constant acceleration a_c , assuming initial conditions are specified at $t = 0$:

$$v(t) = v_o + a_c t \quad s(t) = s_o + v_o t + \frac{1}{2} a_c t^2 \quad v^2 = v_o^2 + 2a_c (s - s_o)$$

Particle Curvilinear Motion:

Cartesian:

$$\vec{v} = v\hat{i} + y\hat{j} + z\hat{k} \quad \vec{a} = \ddot{x}\hat{i} + \ddot{y}\hat{j} + \ddot{z}\hat{k}$$

Normal/Tangential:

$$\vec{v} = v\hat{u}_t \quad \vec{a} = v\hat{u}_t + \frac{v^2}{\rho}\hat{u}_n \quad \text{where } \rho = \frac{[1 + (dy/dx)^2]^{3/2}}{|d^2y/dx^2|}$$

Polar/Cylindrical:

$$\vec{v} = \dot{r}\hat{u}_r + r\dot{\theta}\hat{u}_\theta + z\hat{k} \quad \vec{a} = (\ddot{r} - r\dot{\theta}^2)\hat{u}_r + (r\ddot{\theta} + 2\dot{r}\dot{\theta})\hat{u}_\theta + \ddot{z}\hat{k}$$

Time Derivative of a Vector:

Unit Vector: $\dot{\hat{u}}(t) = \vec{\omega}_u \times \hat{u}$

$$\text{General vector } \vec{A}: \quad \dot{\vec{A}}(t) = \dot{A}\hat{u}_A + \vec{\omega}_A \times \vec{A}, \\ \ddot{\vec{A}}(t) = \ddot{A}\hat{u}_A + 2\dot{\vec{\omega}}_A \times \dot{A}\hat{u}_A + \dot{\vec{\omega}}_A \times \vec{A} + \vec{\omega}_A \times (\vec{\omega}_A \times \vec{A})$$

General Relative Motion:

$$\vec{v}_B = \vec{v}_A + \vec{v}_{B/A} = \vec{v}_A + \vec{\omega} \times \vec{r}_{B/A}$$

$$\vec{a}_B = \vec{a}_A + \vec{a}_{B/A} = \vec{a}_A + \vec{\omega}_{AB} \times \vec{r}_{B/A} + \dot{\vec{\omega}}_{AB} \times (\vec{\omega}_{AB} \times \vec{r}_{B/A}) = \vec{a}_A + \vec{\omega}_{AB} \times \vec{r}_{B/A} - \omega_{AB}^2 \vec{r}_{B/A}$$

Work and Energy: $\Sigma U_{1 \rightarrow 2} = T_2 - T_1$ where $U_{1 \rightarrow 2} = \int_1^2 \vec{F} \cdot d\vec{r}$ and $T = \frac{1}{2}mv^2$

Conservation of Energy (assumes only conservative forces): $T_1 + V_2 = T_1 + V_2$

Rigid Bodies: use Total Kinetic Energy: $T = \frac{1}{2}mv_c^2 + \frac{1}{2}I_c\omega^2$

Potential Energy:

Terrestrial Gravity: $V = mgh$ (Rigid Body: $V = mgy_G$).
 $g \cong 9.81 \frac{\text{m}}{\text{s}^2}$ or $32.2 \frac{\text{ft}}{\text{s}^2}$

Linear Elastic Spring:

Compression/Extension: $V = \frac{1}{2}k(l - l_0)^2$

Rotational: $V = \frac{1}{2}k_t(\theta - \theta_0)^2$

Power: $P = \vec{F} \cdot \vec{v}$

1 hP = 550 ft-lb/s \approx 745.7 W

Efficiency: $\varepsilon = \frac{\text{power output}}{\text{power input}}$

Linear Impulse and Momentum: $\sum \vec{l}_{1 \rightarrow 2} = \vec{p}_2 - \vec{p}_1$, where $\vec{l}_{1 \rightarrow 2} = \int_1^2 \vec{F} dt$ and $\vec{p} = m\vec{v}$

Rigid Body: $\vec{p} = m\vec{v}_G$

Linear Impulse-Momentum for Systems of Particles: $\sum m\vec{v}_1 + \sum \int_{t_1}^{t_2} \vec{F} dt = \sum m\vec{v}_2$

Coefficient of Restitution for Systems of Particles: $v_B^+ - v_A^+ = -e(v_B^- - v_A^-)$

Impulse-Momentum for Rigid Bodies:

$$\begin{array}{ll}
 \text{Linear} & \text{Angular} \\
 m\vec{v}_{G_1} + \int_{t_1}^{t_2} \sum \vec{F} dt = m\vec{v}_{G_2} & I_G \vec{\omega}_1 + \int_{t_1}^{t_2} \sum \vec{M}_G dt = I_G \vec{\omega}_2 \\
 & (\vec{h}_P)_1 + \int_{t_1}^{t_2} \sum \vec{M}_P dt = (\vec{h}_P)_2 \\
 & \vec{h}_P = I_G \vec{\omega} + \vec{r} \times m\vec{v}_G
 \end{array}$$

Coefficient of Restitution - Rigid Bodies: $(v_B^+)_n - (v_A^+)_n = -e((v_B^-)_n - (v_A^-)_n)$

Equations of Motion: $\vec{F} = m\vec{a}_G$ $\vec{M}_P = I_G \vec{\alpha}_B + \vec{r}_{G/P} \times m\vec{a}_G$

Mass Moment of Inertia: $I = \int r^2 dm$
 $I = k^2 m$ (k = Radius of Gyration)

Parallel Axis Theorem: $I = I_G + md^2$

Centroidal Moments of Inertia:

Thin Uniform Rod: $\frac{1}{12}mL^2$ Thin Ring: mR^2 Circular Disk: $\frac{1}{2}mR^2$

Sphere: $\frac{2}{5}mR^2$ Rectangular Plate: $\frac{1}{12}m(a^2 + b^2)$

(Graphics from www.msdsgeometry.com, www.mei.org.uk/month_item_12)

2.3.2 mass moment of inertia

Properties of solids. Volume V , center of mass and centroid G , and mass moments of inertia for homogeneous bodies.

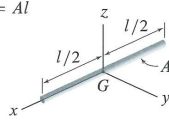
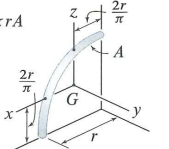
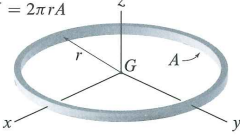
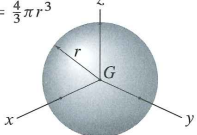
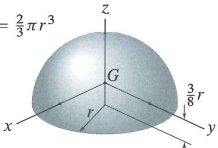
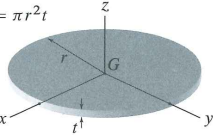
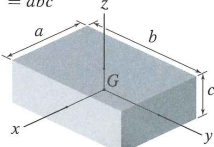
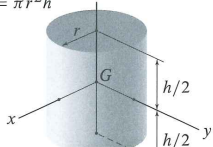
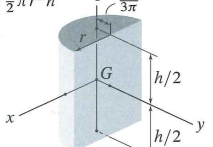
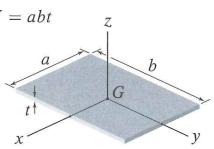
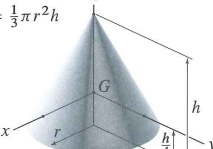
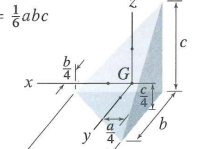
<p>Thin Rod</p> <p>$V = Al$</p>  <p>$I_x = 0, I_y = I_z = \frac{1}{12}ml^2$</p>	<p>Thin Quarter-Circular Rod</p> <p>$V = \frac{1}{2}\pi rA$</p>  <p>$I_x = I_z = mr^2(\frac{1}{2} - \frac{4}{\pi^2}),$ $I_y = mr^2(1 - \frac{8}{\pi^2})$</p>	<p>Thin Ring</p> <p>$V = 2\pi rA$</p>  <p>$I_x = I_y = \frac{1}{2}mr^2, I_z = mr^2$</p>
<p>Sphere</p> <p>$V = \frac{4}{3}\pi r^3$</p>  <p>$I_x = I_y = I_z = \frac{2}{5}mr^2$</p>	<p>Hemisphere</p> <p>$V = \frac{2}{3}\pi r^3$</p>  <p>$I_x = I_y = \frac{83}{320}mr^2, I_z = \frac{2}{5}mr^2$</p>	<p>Thin Circular Disk</p> <p>$V = \pi r^2t$</p>  <p>$I_x = I_y = \frac{1}{4}mr^2, I_z = \frac{1}{2}mr^2$</p>
<p>Rectangular Prism</p> <p>$V = abc$</p>  <p>$I_x = \frac{1}{12}m(b^2 + c^2), I_y = \frac{1}{12}m(a^2 + c^2),$ $I_z = \frac{1}{12}m(a^2 + b^2)$</p>	<p>Cylinder</p> <p>$V = \pi r^2h$</p>  <p>$I_x = I_y = \frac{1}{12}m(3r^2 + h^2),$ $I_z = \frac{1}{2}mr^2$</p>	<p>Half Cylinder</p> <p>$V = \frac{1}{2}\pi r^2h$</p>  <p>$I_x = \frac{1}{12}mh^2 + mr^2(\frac{1}{4} - \frac{16}{9\pi^2}),$ $I_y = \frac{1}{12}mh^2 + \frac{1}{4}mr^2,$ $I_z = mr^2(\frac{1}{2} - \frac{16}{9\pi^2})$</p>
<p>Thin Rectangular Plate</p> <p>$V = abt$</p>  <p>$I_x = \frac{1}{12}mb^2, I_y = \frac{1}{12}ma^2,$ $I_z = \frac{1}{12}m(a^2 + b^2)$</p>	<p>Cone</p> <p>$V = \frac{1}{3}\pi r^2h$</p>  <p>$I_x = I_y = \frac{3}{80}m(4r^2 + h^2),$ $I_z = \frac{3}{10}mr^2$</p>	<p>Right Tetrahedron</p> <p>$V = \frac{1}{6}abc$</p>  <p>$I_x = \frac{3}{80}m(b^2 + c^2), I_y = \frac{3}{80}m(a^2 + c^2),$ $I_z = \frac{3}{80}m(a^2 + b^2)$</p>

Chapter 3

Discussions

Local contents

3.1	week 14, my solution to first problem	16
3.2	week 10	17
3.3	week 11 NOV 12 to NOV 18	20

3.1 week 14, my solution to first problem

Example 8.5: The 2 kg rod ACB supports two 4 kg disks at its ends. If both disks are given a clockwise angular velocity of 5 rad/s while the rod is held stationary and then released, determine the angular velocity of the rod after both disks have stopped spinning relative to the rod due to frictional resistance at the pins A and B. Motion is in the horizontal plane. Neglect friction at pin O.

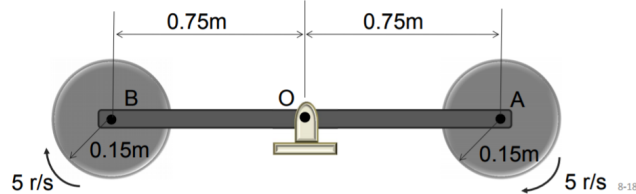

```
In[77]:= L0 = 2 * 0.75;
mBar = 2;
mDisk = 4;
w1Disk = 5;
rDisk = 0.15;
```

Find initial h_1 about O. Since there are two disks, and the rod is not rotating initially, then only contribution to angular momentum comes from the spinning disks (two of them).

```
In[82]:=
I1 = 2 * (1/2 * mDisk * rDisk^2)
```

```
Out[82]= 0.09
```

```
In[83]:= h1 = I1 * w1Disk
```

```
Out[83]= 0.45
```

Now we find final angular momentum about O. Assume final angular speed of the whole system (now as rigid body) is w_2 . Notice use of parallel axis theorem now

```
In[85]:= I2 = (1/12 * mBar * L0^2 + 2 * (1/2 * mDisk * rDisk^2 + mDisk * (L0/2)^2))
```

```
Out[85]= 4.965
```

```
In[86]:= h2 = I2 * w2
```

```
Out[86]= 4.965 * w2
```

Now equate $h_1 = h_2$ and solve for w_2

```
In[87]:= equation = h1 == h2
```

```
Out[87]= 0.45 == 4.965 * w2
```

3.2 week 10

My solution is below

3.2.1 Problem 1

General Motion: Velocity

Example: The cylinder B rolls on the fixed cylinder A without slipping. The connecting bar CD is rotating with an angular velocity of $\omega_{CD} = 5 \text{ rad/s}$.

Determine:

- 1) the angular velocity of cylinder B
- 2) the velocity of point F

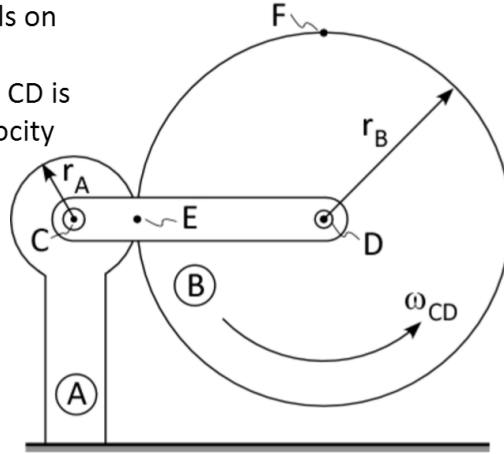

3.2.1.1 Part 1

Notice that the point E is not on the bar CD . It is the point where the disks meet at this instance shown.

$$\begin{aligned}\vec{V}_D &= \vec{V}_C + \vec{\omega}_{CD} \times \vec{r}_{D/C} \\ &= 0 + \omega_{CD} \hat{k} \times (r_A + r_B) \hat{i} \\ &= \omega_{CD} (r_A + r_B) \hat{j}\end{aligned}\quad (1)$$

But we also see that \vec{V}_D can be written as

$$\begin{aligned}\vec{V}_D &= \vec{V}_E + \vec{\omega}_{disk} \times \vec{r}_{D/E} \\ &= 0 + \omega_{disk} \hat{k} \times r_B \hat{i} \\ &= \omega_{disk} r_B \hat{j}\end{aligned}\quad (2)$$

Where in the above we used the fact that $\vec{V}_E = \vec{V}_C = 0$ at the instance shown. Equating (1) and (2)

$$\begin{aligned}\omega_{CD} (r_A + r_B) &= \omega_{disk} r_B \\ \omega_{disk} &= \omega_{CD} \frac{r_A + r_B}{r_B}\end{aligned}\quad (3)$$

3.2.1.2 Part 2

$$\begin{aligned}\vec{V}_F &= \vec{V}_D + \vec{\omega}_{disk} \times \vec{r}_{F/D} \\ &= \omega_{CD} (r_A + r_B) \hat{j} + \omega_{disk} \hat{k} \times r_B \hat{j}\end{aligned}$$

Hence

$$\begin{aligned}\vec{V}_F &= -\omega_{disk} r_B \hat{i} + \omega_{CD} (r_A + r_B) \hat{j} \\ &= -\omega_{CD} \frac{r_A + r_B}{r_B} r_B \hat{i} + \omega_{CD} (r_A + r_B) \hat{j} \\ &= \omega_{CD} (r_A + r_B) \hat{i} + \omega_{CD} (r_A + r_B) \hat{j}\end{aligned}$$

3.2.2 Problem 2

General Motion - Velocity

Example: In the piston system shown, the crank AB has a constant clockwise angular velocity of 2000 RPM.

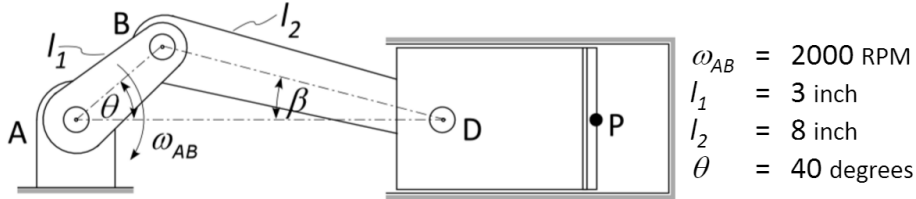

Determine the velocity of point P on the piston for the configuration parameters given above

$$\begin{aligned}\vec{V}_D &= \vec{V}_B + \vec{V}_{D/B} \\ &= \vec{V}_B + \vec{\omega}_{BD} \times \vec{r}_{D/B}\end{aligned}\quad (1)$$

But

$$\begin{aligned}\vec{V}_B &= \vec{V}_A + \vec{\omega}_{AB} \times \vec{r}_{B/A} \\ &= 0 - \omega_{AB} \hat{k} \times (L_1 \cos \theta \hat{i} + L_1 \sin \theta \hat{j}) \\ &= -\omega_{AB} L_1 \cos \theta \hat{j} + \omega_{AB} L_1 \sin \theta \hat{i}\end{aligned}\quad (2)$$

Where

$$\omega_{AB} = 2000 \left(\frac{2\pi}{60} \right) = \frac{200}{3} \pi = 209.4395 \text{ rad/sec}$$

The angle β can be found as follows

$$\begin{aligned}\frac{\sin \theta}{L_2} &= \frac{\sin \beta}{L_1} \\ \sin \beta &= \frac{L_1}{L_2} \sin \theta = \frac{3}{8} \sin \left(40 \left(\frac{\pi}{180} \right) \right) = 0.241 \text{ radians} \\ &= 13.808^\circ\end{aligned}$$

Now we know everything to evaluate (1). Therefore

$$\begin{aligned}\vec{V}_D &= \vec{V}_B + \vec{\omega}_{BD} \times \vec{r}_{D/B} \\ &= (-\omega_{AB} L_1 \cos \theta \hat{j} + \omega_{AB} L_1 \sin \theta \hat{i}) + \omega_{BD} \hat{k} \times (L_2 \cos \beta \hat{i} - L_2 \sin \beta \hat{j}) \\ &= (-\omega_{AB} L_1 \cos \theta \hat{j} + \omega_{AB} L_1 \sin \theta \hat{i}) + \omega_{BD} L_2 \cos \beta \hat{j} + \omega_{BD} L_2 \sin \beta \hat{i} \\ &= \hat{i} (\omega_{AB} L_1 \sin \theta + \omega_{BD} L_2 \sin \beta) + \hat{j} (-\omega_{AB} L_1 \cos \theta + \omega_{BD} L_2 \cos \beta)\end{aligned}\quad (3)$$

But the y component of $\vec{V}_D = 0$ since D can only move in x direction. Therefore from the above

$$\begin{aligned}-\omega_{AB} L_1 \cos \theta + \omega_{BD} L_2 \cos \beta &= 0 \\ \omega_{BD} &= \omega_{AB} \frac{L_1 \cos \theta}{L_2 \cos \beta}\end{aligned}\quad (4)$$

Substituting (4) into the x component of (3) gives the answer we want

$$\begin{aligned}
 \bar{V}_D &= \hat{i} \left(\omega_{AB} L_1 \sin \theta + \left(\frac{L_1 \cos \theta}{L_2 \cos \beta} \omega_{AB} \right) L_2 \sin \beta \right) \\
 &= \hat{i} \left(L_1 \sin \theta + \left(\frac{L_1 \cos \theta}{L_2 \cos \beta} \right) L_2 \sin \beta \right) \omega_{AB} \\
 &= \hat{i} \left(3 \sin \left(40 \left(\frac{\pi}{180} \right) \right) + \frac{3 \cos \left(40 \left(\frac{\pi}{180} \right) \right) \sin \left(13.808 \left(\frac{\pi}{180} \right) \right)}{\cos \left(13.808 \left(\frac{\pi}{180} \right) \right)} \right) 209.4395 \\
 &= 522.170 \hat{i} \text{ inch/sec} \\
 &= 43.514 \hat{i} \text{ ft/sec}
 \end{aligned}$$

And $\omega_{BD} = \omega_{AB} \frac{L_1 \cos \theta}{L_2 \cos \beta} = 209.4395 \frac{3 \cos \left(40 \left(\frac{\pi}{180} \right) \right)}{8 \cos \left(13.808 \left(\frac{\pi}{180} \right) \right)} = 61.955 \text{ rad/sec}$

3.3 week 11 NOV 12 to NOV 18

My solution is below

3.3.1 Problem 6 3 Example 1

Linkage - Acceleration

Example 5.15: A 3-in. radius drum is rigidly attached to a 5-in. radius drum as shown. The 3-in. drum rolls without sliding on the surface shown, and a cord is wound around 5-in. drum. At the instant shown end D of the cord has a velocity of 8 in/s and an acceleration of 30 in/s², both directed to the left

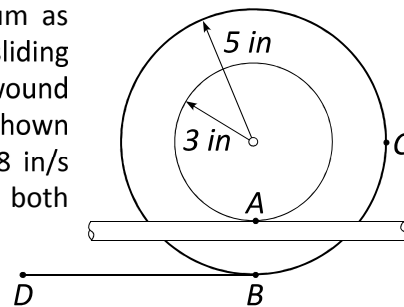

Determine the accelerations of points A , B , and C of the drum.

Given

$$\begin{aligned}\vec{V}_D &= -8\hat{i} \\ \vec{a}_D &= -30\hat{i}\end{aligned}$$

But also (assuming cord is not extensible)

$$\begin{aligned}\vec{V}_B &= -8\hat{i} \\ \vec{a}_B &= -30\hat{i}\end{aligned}$$

Since the point B is also on the large disk, its velocity can be used to find the angular velocity of the disk. The disk is spinning in the clockwise direction. Using $V_B = r\omega_{disk}$, where $r = 5$ inch, then $\omega_{disk} = \frac{-8}{5} = -1.6$ rad/sec or

$$\vec{\omega}_{disk} = -1.6\hat{k}$$

Similarly $a_B = r\alpha_{disk}$ in the clockwise direction, hence $\alpha_{disk} = \frac{a_B}{r} = \frac{-30}{5} = -6$ rad/sec²

$$\vec{\alpha}_{disk} = -6\hat{k}$$

Now

$$\vec{a}_A = \vec{a}_B + \vec{\alpha}_{AB} \times \vec{r}_{A/B} - \omega_{AB}^2 \vec{r}_{A/B}$$

Where $\vec{r}_{A/B} = (r_2 - r_1)\hat{j} = (5 - 3)\hat{j} = 2\hat{j}$ and the above becomes

$$\begin{aligned}\vec{a}_A &= -30\hat{i} + (-6\hat{k} \times 2\hat{j}) - (-1.6)^2 (2\hat{j}) \\ &= -30\hat{i} + (12\hat{i}) - 5.12\hat{j} \\ &= -18\hat{i} - 5.12\hat{j}\end{aligned}$$

Now

$$\vec{a}_C = \vec{a}_O + \vec{\alpha}_{OC} \times \vec{r}_{C/O} - \omega_{OC}^2 \vec{r}_{C/O}$$

Where O is the center of the disk. Since disk is not sliding, then $\vec{a}_O = 0$ and $\vec{r}_{C/O} = 5\hat{i}$. The above becomes

$$\begin{aligned}\vec{a}_C &= -6\hat{k} \times 5\hat{i} - (-1.6)^2 5\hat{i} \\ &= -30\hat{j} - 12.8\hat{i}\end{aligned}$$

3.3.2 Problem 6 3 Example 2 rev2

Linkage - Acceleration

Example 5.16: The disk at A is subjected to the angular motion (velocity and acceleration) shown.

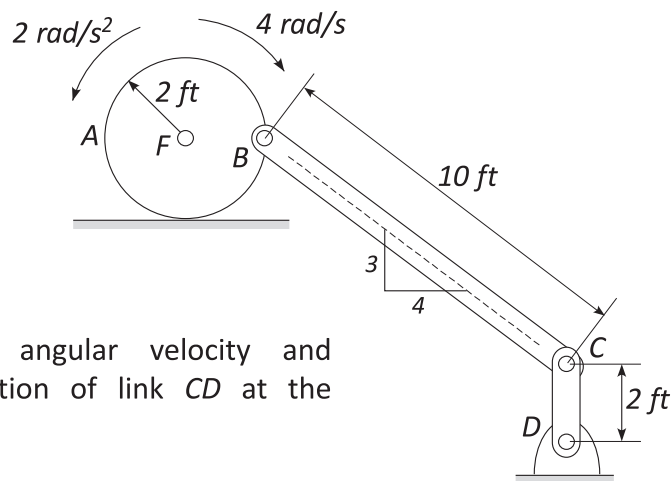

Determine the angular velocity and angular acceleration of link CD at the instant shown.

32

Chapter 4

Exams

Local contents

4.1	First exam	24
4.2	Second exam	31
4.3	Final exam	42

4.1 First exam

4.1.1 key solution to first exam

ME 240 / EMA 202, Fall 2017
Midterm #1, closed book/notes, 60 min.

Name: _____

Question 1 (35 points)

A 70kg snowboarder starts from rest at point A and travels downhill to hit a jump at point B. His velocity at point B is 12m/s. He leaves the jump at an angle θ with respect to the ground, then lands at point C.

Let angles $\phi = 30^\circ$ and $\theta = 40^\circ$

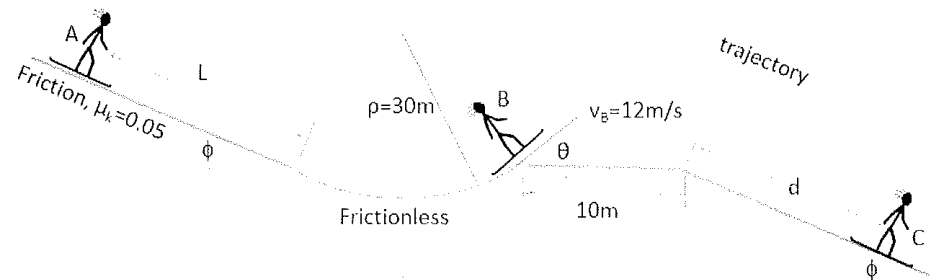

- Calculate the normal force between the snowboarder and the ground at point B just before he leaves the jump.
- Calculate the distance d where the snowboarder touches down on the landing ramp.
- Calculate the distance L to the starting position A, such that the snowboarder reaches 12m/s at point B. Assume the kinetic friction coefficient on the slope is 0.05, and that the curved portion of the ramp is frictionless.

A) Normal force @ pt. B

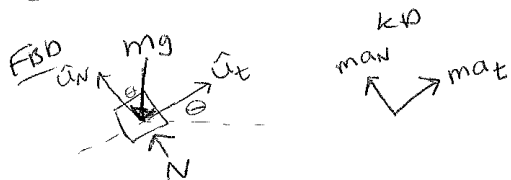

$$\sum F_N: N - mg \cos \theta = m a_n \quad \text{w/} \quad a_n = \frac{v^2}{\rho} = \frac{(12 \text{ m/s})^2}{30 \text{ m}}$$

$$N = m \frac{v^2}{\rho} + mg \cos \theta$$

$$N = 70 \text{ kg} \left(\frac{(12 \text{ m/s})^2}{30 \text{ m}} \right) + 70 \text{ kg} (9.81 \text{ m/s}^2) \cos 40^\circ$$

$$N = 862.0 \text{ N}$$

B) find distance d for landing

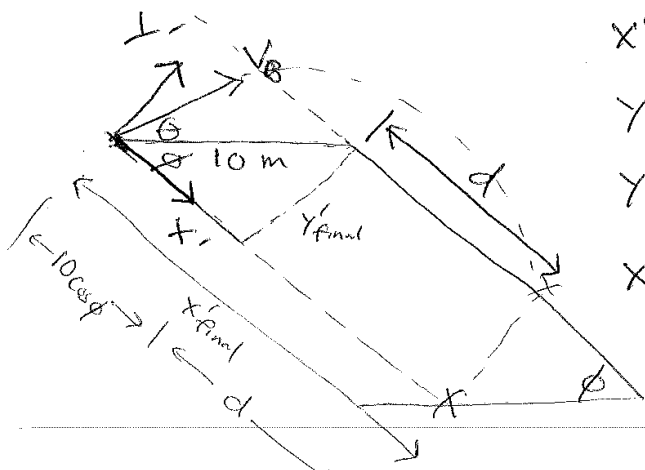

$$X'_0 = 0$$

$$Y'_0 = 0$$

$$Y'_{\text{final}} = 10 \text{ m} \sin \phi$$

$$X'_{\text{final}} = d + 10 \cos \phi$$

Acceleration

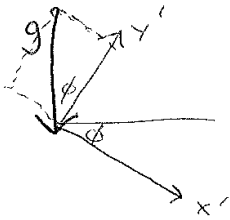

$$a_{x'} = g \sin \phi$$

$$a_{y'} = -g \cos \phi$$

Initial velocity

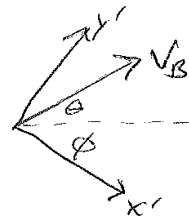

$$V_{0x'} = V_B \cos(\theta + \phi)$$

$$V_{0y'} = V_B \sin(\theta + \phi)$$

$$x) X'_f = X'_0 + V_{0x'} t + \frac{a_{x'}}{2} t^2$$

$$y) Y'_f = Y'_0 + V_{0y'} t + \frac{a_{y'}}{2} t^2 \rightarrow \text{use } y \text{ to find } t$$

$$10 \sin \phi = 0 + V_B \sin(\theta + \phi) t - \frac{g \cos \phi}{2} t^2$$

$$0 = \frac{-9.81 \text{ m/s}^2 \cos 30^\circ}{2} t^2 + 12 \text{ m/s} \sin(40^\circ + 30^\circ) t - 10 \text{ m/s} \sin \phi$$

$$0 = -4.248 t^2 + 11.276 t - 5 \rightarrow \text{solve w/ quadratic eqn}$$

$$t = 2.09 \text{ \& } 0.563 \text{ sec}$$

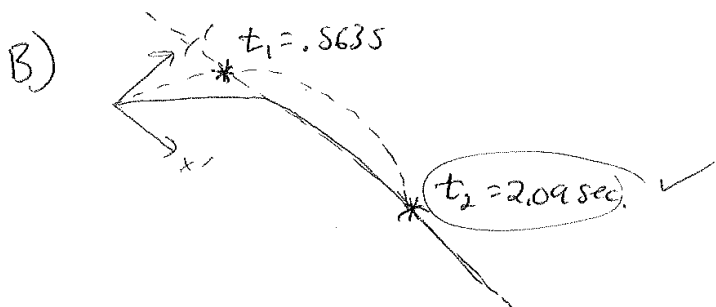

x eqn) $d + 10 \cos \phi = 0 + v_B \cos(\theta + \phi)t + \frac{g \sin \phi}{2} t^2$

$$d = -10 \text{ m} \cos(30^\circ) + 12 \text{ m/s} \cos(70^\circ)(2.09 \text{ s}) + \frac{9.81 \text{ m/s}^2 \sin 30^\circ}{2} (2.09)^2$$

$$d = 10.63 \text{ m}$$

C) How far up ramp, L to start? released from rest $v_i = 0 \text{ m/s}$

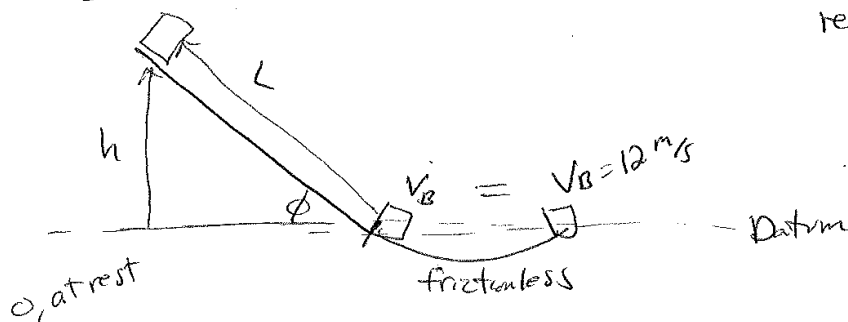

$$V_1 + V_1 + U_{12} = T_2 + V_2$$

$\text{NC} \qquad \qquad \qquad \text{Datum}$

$$\left\{ \begin{array}{l} V_1 = mgh \text{ w/ } h = L \sin \phi \\ T_2 = \frac{1}{2} m v_B^2 \\ U_{12} = -F_f L = -F_f L \end{array} \right.$$

$\rightarrow \sum F_{y'}: N - mg \cos \phi = m a_{y'}^0$

$$N = mg \cos \phi$$

Friction $F_f = \mu_k N = \mu_k mg \cos \phi$

W-E

$$m g (L \sin \phi) + -\mu_k m g \cos \phi L = \frac{1}{2} m v_B^2$$

$$L = \frac{1}{2} v_B^2 \left(\frac{1}{g \sin \phi - \mu_k g \cos \phi} \right) = 16.06 \text{ m}$$

ME 240 / EMA 202, Fall 2017
 Midterm #1, closed book/notes, 60 min.

Name: _____

Question 2 (30 points)

It is observed that a 50kg block B begins to slide on the turntable 10 seconds after the turntable begins to spin.

Knowing that the turntable has a constant angular acceleration of 0.1 rad/s^2 , determine the coefficient of static friction between the block and the turntable.

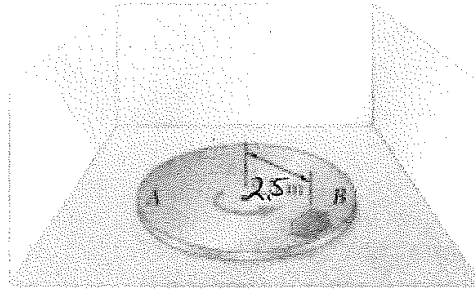

$r = 2.5 \text{ m}$

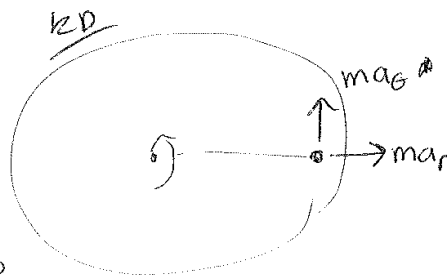
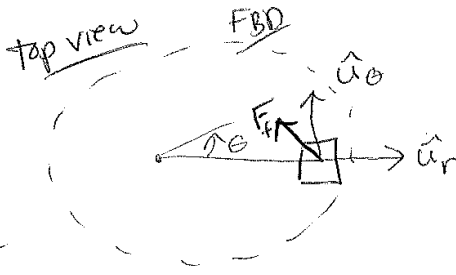

polar

$$\vec{a} = (\ddot{r} - r\dot{\theta}^2)\hat{u}_r + (r\ddot{\theta} + 2\dot{r}\dot{\theta})\hat{u}_\theta$$

Before sliding $\dot{r} = 0$ & $\ddot{r} = 0$

$$\vec{a} = -r\dot{\theta}^2\hat{u}_r + r\ddot{\theta}\hat{u}_\theta \quad \text{w/} \quad \ddot{\theta} = 0.1 \text{ r/s}^2$$

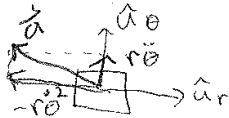

Side view

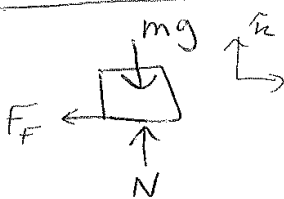

$$\uparrow \sum F_z: N - mg = m a_z \quad \text{flat disc}$$

$$N = mg$$

@ impending slip

$$F_f = \mu_s N = \mu_s mg$$

$\vec{F} = m\vec{a}$ - friction f_r acts in the direction of total acceleration

$$\mu_s mg = m |\vec{a}| = m \sqrt{(-r\ddot{\theta}^2)^2 + (r\ddot{\theta})^2}$$

$$\mu_s = \frac{1}{g} \sqrt{(-r\ddot{\theta}^2)^2 + (r\ddot{\theta})^2}$$

w/ $r = 2.5 \text{ m}$
 $g = 9.81 \text{ m/s}^2$
 $\ddot{\theta} = 0.1 \text{ rad/s}^2$

$$\mu_s = 0.256$$

$\dot{\theta} = \ddot{\theta} t = (0.1 \text{ rad/s}^2)(10 \text{ sec})$
 $\dot{\theta} = 1 \text{ rad/s}$

or in N-T coords

$$\vec{a} = \dot{v} \hat{u}_t + \frac{v^2}{\rho} \hat{u}_n$$

$$|\vec{a}| = \sqrt{\dot{v}^2 + \left(\frac{v^2}{\rho}\right)^2}$$

w/ $\dot{v} = r\ddot{\theta} = 2.5 \text{ m} (0.1 \text{ rad/s}^2)$
 $\dot{v} = 0.25 \text{ m/s}^2$

$v = \dot{v} (10 \text{ sec}) = 2.5 \text{ m/s}$
 $\rho = 2.5 \text{ m}$

ME 240 / EMA 202, Fall 2017
 Midterm #1, closed book/notes, 60 min.

Name: _____

Question 3 (35 points)

The two crates A and B of mass $m_A=100$ kg and $m_B=70$ kg, respectively, are connected by a system of pulleys. The system is initially at rest, when a man starts pushing on crate A with a constant 350N force. The man's pushing force is at an angle of 20° with respect to the horizontal. Neglect the mass of the cables and friction in the pulleys.

If $\mu_k = 0.3$, determine the distance the man pushes crate A to achieve a speed of 3m/s at crate A.

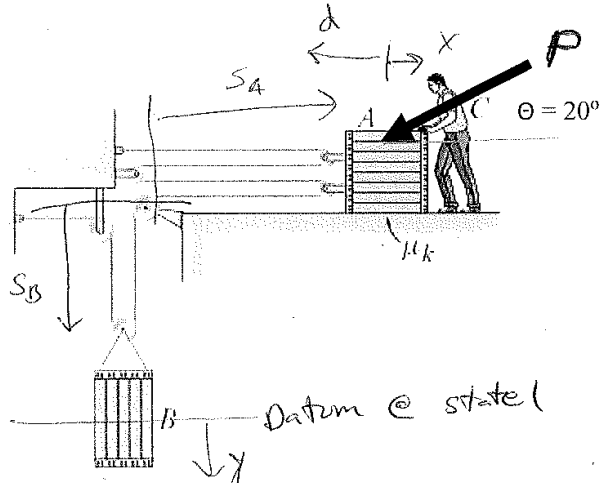

W-E $V_1 = 0$, $V_2 = 3 \text{ m/s}$, $P = 350 \text{ N}$

rope eqn

$$L = 4S_A + 2S_B$$

$$\dot{L} = 0 = 4V_A + 2V_B$$

$$\boxed{2V_A = V_B} \quad \& \quad y = 2d$$

$$T_1 + V_1 + U_{1-2}^{ext} + U_{1-2}^{int} = T_2 + V_2$$

@ rest Datum ext INT 0, for cables

$$T_2 = \frac{1}{2} m_A V_A^2 + \frac{1}{2} m_B V_B^2 = \frac{1}{2} (m_A + 4m_B) V_A^2$$

$$V_2 = -m_B g y_2$$

$$U_{1-2}^{ext} = \vec{F} \cdot (-d\hat{i})$$

F_x component

$$\rightarrow \sum F_{x_A}: F_f - P \cos \theta = m a_{x_A}$$

$$\uparrow \sum F_{y_A}: N_A - m_A g - P \sin \theta = m a_{y_A}^0$$

$$N_A = m_A g + P \sin \theta$$

$$F_f = \mu_k N_A = \mu_k m_A g + \mu_k P \sin \theta$$

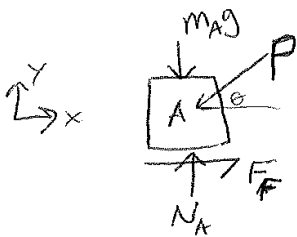

From ΣF_{x_A} :

external force $\vec{F}_x = F - P \cos \theta$

$$\vec{F}_x = (\mu_k m_A g + \mu_k P \sin \theta - P \cos \theta) \uparrow$$

$$U_{12, \text{ext}} = \vec{F}_x \cdot (-d\hat{i}) = (-\mu_k m_A g - \mu_k P \sin \theta + P \cos \theta) d$$

Back to W-E $U_{12, \text{ext}} = T_2 + V_2$

$$(-\mu_k m_A g - \mu_k P \sin \theta + P \cos \theta) d = \frac{1}{2} (m_A + 4m_B) V_{A2}^2 - m_B g \sqrt{2} \cdot 2d$$

$$d (-\mu_k m_A g - \mu_k P \sin \theta + P \cos \theta + m_B g \sqrt{2}) = \frac{1}{2} (m_A + 4m_B) V_{A2}^2$$

$$d = \frac{\frac{1}{2} (m_A + 4m_B) (3 \text{ m/s})^2}{(-0.3 \cdot 100 \text{ kg} \cdot 9.81 \text{ m/s}^2 - 0.3 \cdot 350 \text{ N} \sin 20^\circ + 350 \text{ N} \cos 20^\circ + 70 \text{ kg} \cdot 9.81 \text{ m/s}^2 \cdot \sqrt{2})}$$

$$d = \frac{\frac{1}{2} (100 \text{ kg} + 4 \cdot 70 \text{ kg}) (3 \text{ m/s})^2}{(-0.3 \cdot 100 \text{ kg} \cdot 9.81 \text{ m/s}^2 - 0.3 \cdot 350 \text{ N} \sin 20^\circ + 350 \text{ N} \cos 20^\circ + 70 \text{ kg} \cdot 9.81 \text{ m/s}^2 \cdot \sqrt{2})}$$

$$d = 1.246 \text{ m}$$

4.2 Second exam

4.2.1 key solution to Second exam

ME 240 / EMA 202, Fall 2017
Midterm #2, closed book/notes, 60 min.

Name: Solutions

Instructions

- Show all of your work.
- To maximize opportunities for partial credit, solve problems symbolically to the extent possible and substitute numerical values at the end.
- Include free body diagrams for all equilibrium equations.
- The only notes allowed are the equations provided with this exam.
- The use of cell phones is prohibited.
- The instructors and the University of Wisconsin expect the highest standards of honesty and integrity in the academic performance of its students. It is important that the work submitted on this examination is yours and yours alone.
- Receiving or giving aid in an examination or using notes on a closed note exam will be considered cheating and will result in a grade of F and the case being reported to the Dean of Students Office.

Circle Your Discussion Section:

EMA 202	Time	TA
301	8:50	Peter Grimmer
302	9:55	Peter Grimmer
303	11:00	Peter Grimmer
304	12:05	Aaron Wright
305	1:20	Aaron Wright
306	2:25	AJ Gross
307	12:05	Shu Wang
ME 240		
301	8:50	AJ Gross
302	9:55	Shu Wang
303	11:00	Jenna Thorp
304	12:05	Jenna Thorp
305	1:20	Guannan Guo
306	2:25	Guannan Guo

Grading:

Q1	/34
Q2	/33
Q3	/33
Total	/100

ME 240 / EMA 202, Fall 2017
 Midterm #2, closed book/notes, 60 min.

Name: _____

Question 1 (34 points)

In the planetary gear system shown, the radius of gears A, B, C, and D is 30 mm and the radius of the outer gear E is 90 mm. Knowing that gear E has a constant angular velocity of 180 rpm clockwise and that the central gear A has a constant angular velocity of 240 rpm clockwise, determine

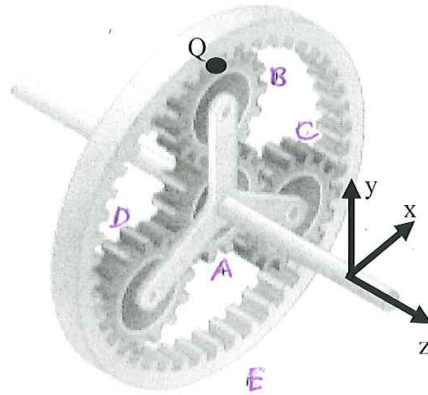

(a) the angular velocity of the planetary gears B, C, and D

(b) the angular velocity of the spider connecting the planetary gears.

(c) the acceleration of point Q. Point Q is attached at the top of gear B where it meets gear E.

$$\vec{\omega}_E = -180 \frac{\text{rev}}{\text{min}} \hat{k} \left(\frac{2\pi \text{ rad}}{1 \text{ rev}} \right) \left(\frac{1 \text{ min}}{60 \text{ sec}} \right) = -6\pi \hat{k}$$

$$\vec{\omega}_A = -240 \frac{\text{rev}}{\text{min}} \hat{k} \left(\frac{2\pi \text{ rad}}{1 \text{ rev}} \right) \left(\frac{1 \text{ min}}{60 \text{ sec}} \right) = -8\pi \hat{k}$$

A) Find ω_B

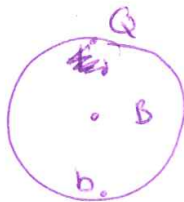
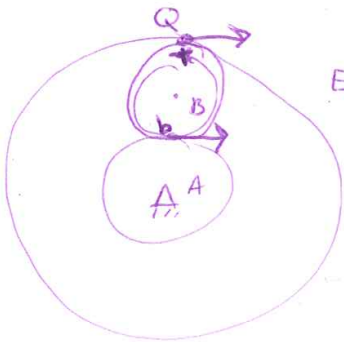

write velocity of pt b & Q
 then solve for ω_B

Gear A, pt. b

$$\vec{V}_b = \vec{V}_A + \vec{\omega}_A \times \vec{r}_{b/A}$$

pinned. $+30\text{mm}\hat{j}$

$$\vec{V}_b = -8\pi \hat{k} \times 30\text{mm}\hat{j}$$

$$\vec{V}_b = 240\pi \text{ mm/s } \uparrow$$

Gear E, pt Q

1, p2

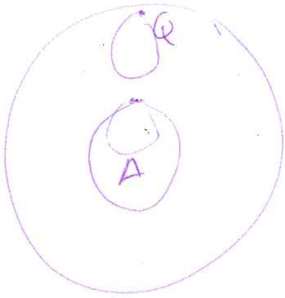

$$\vec{V}_Q = \vec{\omega}_E \times \vec{r}_E = -6\pi \hat{k} \times 90\text{mm} \hat{j}$$

$$\vec{V}_Q = 540\pi \frac{\text{mm}}{\text{s}} \hat{i}$$

Gear B w/ points b & Q

$$\vec{V}_b = \vec{V}_Q + \vec{\omega}_B \times \vec{r}_{b/Q}$$

$$240\pi \hat{i} = 540\pi \hat{i} + \omega_B \hat{k} \times -60\text{mm} \hat{j}$$

$$-300\pi \hat{i} = +60\text{mm} \omega_B \hat{i}$$

$$\vec{\omega}_B = -5\pi \frac{\text{r}}{\text{s}} \hat{k}$$

Same for C & D

B) spider

 $\vec{\omega}_S = ?$ find \vec{V}_B then $\vec{\omega}_S$

gear B

$$\vec{V}_B = \vec{V}_b + \vec{\omega}_B \times \vec{r}_{B/b}$$

$$\vec{V}_B = 240\pi \hat{i} + (-5\pi \hat{k} \times 30\text{mm} \hat{j})$$

$$\vec{V}_B = 240\pi \hat{i} + 150\pi \hat{i} = 390\pi \frac{\text{mm}}{\text{s}} \hat{i}$$

spider

$$\vec{V}_B = \vec{\omega}_S \times \vec{r}_{B/A}$$

$$390\pi \hat{i} = \omega_S \hat{k} \times 60\text{mm} \hat{j} = -60\omega_S \hat{i}$$

$$= -60\omega_S \hat{i}$$

$$\rightarrow \vec{\omega}_S = -6.5\pi \frac{\text{r}}{\text{s}} \hat{k}$$

c) Find \vec{a}_Q , constant ω 's

1, P3

Spider gear B

$$\vec{a}_B = \vec{a}_A + \vec{\alpha}_{\text{spider}} \times \vec{r}_{B/A} - \omega_S^2 \vec{r}_{B/A}$$

$$\vec{a}_B = -(-6.5\pi)^2 60 \text{ mm } \hat{j}$$

$$\vec{a}_B = -7963.94 \text{ mm/s}^2 \hat{j}$$

gear B

$$\vec{a}_Q = \vec{a}_B + \vec{\alpha}_B \times \vec{r}_{Q/B} - \omega_B^2 \vec{r}_{Q/B}$$

$$\vec{a}_Q = -7963.94 \text{ mm/s}^2 \hat{j} - (5\pi)^2 30 \text{ mm } \hat{j}$$

-7402.20 \hat{j}

$$\vec{a}_Q = -15366.14 \text{ mm/s}^2 \hat{j}$$

IC method

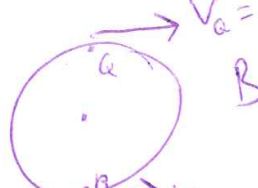
$$\vec{V}_A = 90 \text{ mm} \left(180 \frac{\text{rev}}{\text{min}} \left(\frac{2\pi}{60 \text{ s}} \right) \right) = 1696.46 \frac{\text{mm}}{\text{s}}$$

$$\vec{V}_B = 30 \text{ mm} \left(240 \frac{\text{rev}}{\text{min}} \left(\frac{2\pi}{60 \text{ s}} \right) \right) = 753.98 \frac{\text{mm}}{\text{s}}$$

$$\vec{V}_B = 753.98 \text{ mm/s}$$

$$\tan \theta = \frac{1696.46}{753.98} = \frac{r_{A/IC}}{r_{B/IC}}$$

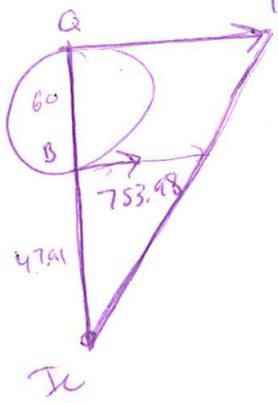

$$\vec{V}_A = \vec{\omega}_B \times \vec{r}_{A/IC}$$

$$\vec{V}_B = \vec{\omega}_B \times \vec{r}_{B/IC}$$

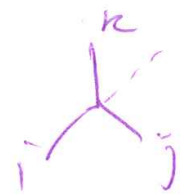

a) $1696.46 = \omega_B \hat{k} \times r_{A/IC} \hat{j} = -\omega_B r_{A/IC} \hat{i}$

b) $753.98 = \omega_B \hat{k} \times r_{B/IC} \hat{j} = -\omega_B r_{B/IC} \hat{i}$

$$\omega_B = \frac{-753.98}{r_{B/IC}}$$

$$\vec{\omega}_B = 75.7 \text{ r/s } \hat{k}$$

$$r_{B/IC} = \frac{753.98}{1696.46} r_{A/IC}$$

$$r_{B/IC} = \frac{753.98}{1696.46} (r_{B/IC} + 60 \text{ mm})$$

$$(1 - 0.44) r_{B/IC} = \frac{753.98}{1696.46} 60 \text{ mm}$$

$$r_{B/IC} = 47.91$$

Spider gear w/ IC

$$\vec{V}_S = \vec{\omega}_B \times \vec{r}_{S/IC}$$

$$= -15.7 \hat{k} \times (47.91 + 30 \text{ mm}) \hat{j}$$

$$V_S = 1223.8 \text{ mm/s}$$

$$\vec{V}_S = \vec{\omega}_S \times \vec{r}_{S/A}$$

$$1223.8 = \omega_S \hat{k} \times 60 \hat{j}$$

$$\omega_S = 2039 \text{ r/s}$$



EMA 202, ~~2021/2022~~
Midterm #2, closed book/notes, 90 min.

Name: _____

Question 2 (33 points)

The pendulum consists of two 8.0 lb concentrated weights positioned as shown on a light but rigid bar. The pendulum is swinging through the vertical position with a clockwise angular velocity $\omega = 6.0$ rad/sec when a 2.0 ounce bullet, traveling with a velocity of $v = 1000$ ft/sec in the direction shown, strikes the lower weight and is embedded in it. Calculate the angular velocity ω_2 that the pendulum has immediately after impact, and find the maximum angular deflection θ of the pendulum.

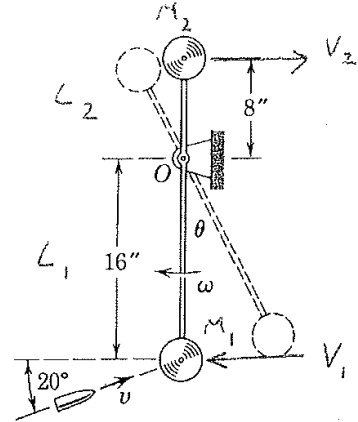

$$W_M = 8 \text{ lb.} \quad W_B = \frac{1}{8} \text{ lb.}$$

$$\omega_0 = 6 \text{ rad/s} \quad v = 1000 \text{ ft/s}$$

SYSTEM

ANGULAR MOMENTUM CONSERVED DURING
IMPACT ABOUT POINT O. $\Rightarrow H_{O1} = H_{O2}$

Direct Impact

$$L_1 \omega_0 = V_1 = \frac{16}{12} \omega_0 \quad V_2 = \frac{8}{12} \omega_0 = L_2 \omega_0$$

$$\uparrow \Rightarrow H_{O1} = -L_1 M_1 V_1 - L_2 M_2 V_2 + L_1 M_0 V_0 \cos 20^\circ$$

$$\text{on } H_{O1} = -\frac{8}{32.2} (6) \left(\frac{16}{12}\right)^2 - \frac{8}{32.2} (6) \left(\frac{8}{12}\right)^2 + \left(\frac{16}{12}\right) \left(\frac{1}{32.2}\right) 1000 \cos 20^\circ$$

$$\Rightarrow H_{O1} = 1.551 \text{ lb-ft-s}$$

After Impact

$$V_1 = L_1 \omega_2 \quad V_2 = L_2 \omega_2$$

$$H_{O2} = L_1^2 (M_0 + M_1) \omega_2 + L_2^2 M_2 \omega_2$$

$$\text{on } H_{O2} = \left(\frac{16}{12}\right)^2 \left[\frac{1}{8} + 8\right] \omega_2 + \left(\frac{8}{12}\right)^2 \frac{8}{32.2} \omega_2$$

$$= (0.559) \omega_2$$

EMA 202, ~~Spring 2012~~

Name: _____

Midterm #2, closed book/notes, 90 min.

(Additional workspace for Question 2)

$$H_{v1} = H_{v2} \Rightarrow \omega_2 = 2.77 \text{ rad/s} \quad \checkmark$$

PINNACOLUM - BOUNCIT WALK - ENERGY APINA IMPACT

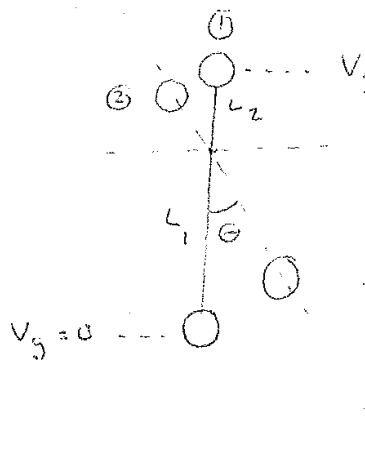

ENERGY CONSERVATION:

$$T_1 + V_1 = T_2 + V_2$$

$$T_1 = \frac{1}{2} (M_0 + M_1) v_1^2 + \frac{1}{2} M_2 v_2^2$$

$$T_1 = \frac{1}{2} \left(\frac{\frac{1}{8} + 8}{32.2} \right) \left(\frac{16}{12} \right)^2 \omega_2^2 + \frac{1}{2} \frac{8}{32.2} \left(\frac{8}{12} \right)^2 \omega_2^2$$

$$T_1 = 2.152 \text{ lb-ft}$$

$$T_2 = 0 \quad V_1 = 0 \quad V_2 = (W_1 + W_0) L_1 (1 - \cos \theta) - W_2 L_2 (1 - \cos \theta)$$

$$V_2 = \left[\left(\frac{1}{8} + 8 \right) \left(\frac{16}{12} \right) - 8 \left(\frac{8}{12} \right) \right] (1 - \cos \theta)$$

$$V_2 = (5.500) (1 - \cos \theta)$$

$$\Rightarrow 2.152 = (5.5) (1 - \cos \theta)$$

$$\Rightarrow \cos \theta = 0.609 \Rightarrow \theta = 52.5^\circ$$

ME 240 / EMA 202, Fall 2017
 Midterm #2, closed book/notes, 60 min.

Name: _____

Question 3 (33 points)

Ball A is traveling purely in the x-direction with velocity V_A when it impacts ball B. Subsequently, ball B impacts ball C. Assume that both collisions have a coefficient restitution e .

Determine the magnitude of the velocity of ball C after it is impacted by ball B in terms of m_A , m_B , m_C , e , V_A , and the angles shown.

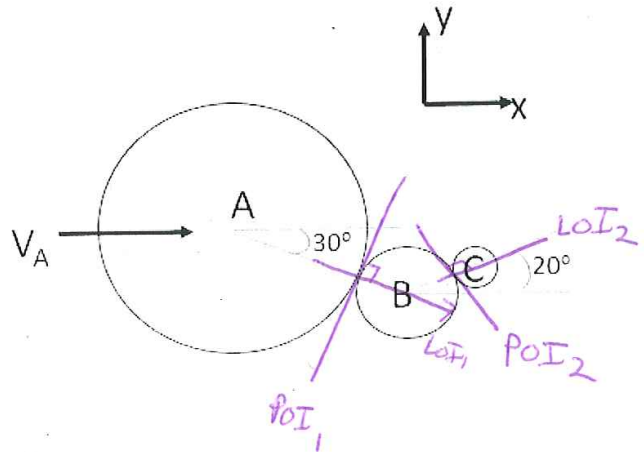

Impact A & B

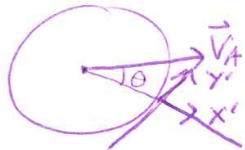

$$\vec{V}_A = V_A \hat{i} = V_A \cos 30^\circ \hat{i}' + V_A \sin 30^\circ \hat{j}'$$

LOI in x' -direction

x') conserv. momentum

$$m_A (V_A \cos 30^\circ) + m_B (V_{Bx'}^-) = m_A (V_{Ax'}^+) + m_B (V_{Bx'}^+)$$

$V_{Ax'}^-$ $0, e \text{ rest}$

COR.

$$e = \frac{V_{Bx'}^+ - V_{Ax'}^+}{V_{Ax'}^- - V_{Bx'}^-}$$

Solve for $V_{Ax'}^+$, want $V_{Bx'}^+$

$$\underline{V_{Ax'}^+ = V_{Bx'}^+ - V_{Ax'}^- e}$$

plug into momentum eqn.

$$m_A V_A \cos 30^\circ = m_A (V_{Bx'}^+ - V_{Ax'}^- e) + m_B V_{Bx'}^+$$

Solve for $V_{Bx'}^+$

$$m_A v_A \cos 30 + m_A e v_A \cos 30 = (m_A + m_B) v_{Bx'}^+$$

$$v_{Bx'}^+ = \frac{m_A}{m_A + m_B} v_A \cos 30 (1 + e)$$

POI in y' direction

$$v_{By'}^- = v_{By'}^+ = \underline{0}$$

Impact @ B & C

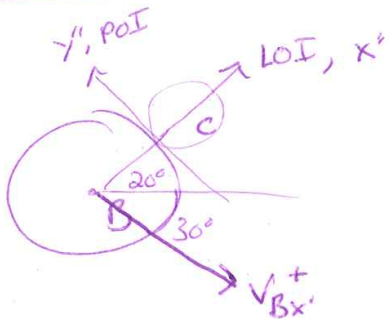

rotate $v_{Bx'}^+$ into x'' & y'' C.S.

$$\vec{v}_{Bx'}^+ = \underbrace{v_B^+ \cos 50}_{v_{Bx''}^+} \hat{i}'' + \underbrace{v_B^+ \sin 50}_{v_{By''}^+} \hat{j}''$$

*notation (++) is after 2nd collision

x'' -direction

$$m_B v_{Bx''}^+ + m_C \underbrace{v_{Cx''}^+}_{0, \text{ @ rest}} = m_B v_{Bx''}^{++} + m_C v_{Cx''}^{++}$$

COR

$$e = \frac{v_{Bx''}^{++} - v_{Cx''}^{++}}{v_{Cx''}^+ - v_{Bx''}^+}$$

want @ $v_{Cx''}^{++}$, solve for $v_{Bx''}^{++}$

$$v_{Bx''}^{++} = v_{Cx''}^{++} - e v_{Bx''}^+$$

$$v_B^+ \cos 50^\circ$$

Sub into momentum, solve for v_C^{++}

$$m_B V_B^+ \cos 50^\circ = m_B (V_{Cx}^{++} - e V_B^+ \cos 50^\circ) + m_C V_{Cx}^{++}$$

$$m_B (1+e) V_B^+ \cos 50^\circ = (m_B + m_C) V_{Cx}^{++}$$

$$V_{Cx}^{++} = \left(\frac{m_B}{m_B + m_C} \right) (1+e) V_B^+ \cos 50^\circ$$

↑

$\frac{m_A}{m_A + m_B}$

$V_A \cos 30^\circ (1+e)$

velocity of B after
1st impact.

$$V_{Cx}^{++} = \left(\frac{m_B}{m_B + m_C} \right) \left(\frac{m_A}{m_A + m_B} \right) (1+e)^2 V_A \cos 30^\circ \cos 50^\circ$$

4.3 Final exam

4.3.1 key solution to Final exam

Not available

Chapter 5

practice exams

Local contents

5.1	practice first midterm exams	44
5.2	practice second midterm exams	92
5.3	practice exam for finals	136

5.1 practice first midterm exams

5.1.1 Fall 2016

5.1.1.1 exam questions

ME 240 / EMA 202, Fall 2016
Midterm #1, closed book/notes, 90 min.

Name: _____

Instructions

- Show all of your work.
- To maximize opportunities for partial credit, solve problems symbolically to the extent possible and substitute numerical values at the end.
- Include free body diagrams for all equilibrium equations.
- The only notes allowed are the equations provided with this exam.
- The use of cell phones is prohibited.
- The instructors and the University of Wisconsin expect the highest standards of honesty and integrity in the academic performance of its students. It is important that the work submitted on this examination is yours and yours alone.
- Receiving or giving aid in an examination or using notes on a closed note exam will be considered cheating and will result in a grade of F and the case being reported to the Dean of Students Office.

Circle Your Discussion Section:

EMA 202	Time	TA
301	8:50	Peter Grimmer
302	9:55	Aswin Rajendram Muthukumar
303	11:00	Aswin Rajendram Muthukumar
304	12:05	Zz Riford
305	1:20	Peter Grimmer
306	2:25	Peter Grimmer
307	12:05	Aaron Wright
ME 240		
301	8:50	Jenna Lynne
302	9:55	Jenna Lynne
303	11:00	Chembian Parthiban
304	12:05	Chembian Parthiban
305	1:20	Aaron Wright
306	2:25	Zz Riford

Grading:

Q1	/10
Q2	/30
Q3	/30
Q4	/30
Total	/100

ME 240 / EMA 202, Fall 2016
Midterm #1, closed book/notes, 90 min.

Name: _____

Question 1 (10 points)

For the following short answer problems, please include any relevant calculations and/or a brief explanation for your answer.

1A (5 points)

A block is traveling with a speed v_o on a smooth surface when the surface suddenly becomes rough with a coefficient of friction of μ causing the block to stop after a distance d . If the block were traveling twice as fast ($2v_o$), how far will it travel on the rough surface before stopping?

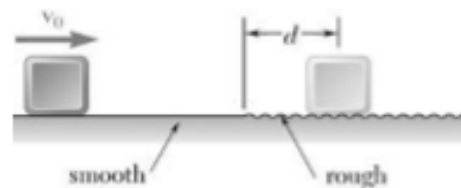

1B (5 points)

Marble A is placed in a hollow tube that is pinned at point B. The tube is swung in a horizontal plane causing the marble to be thrown from the end of the tube. As viewed from the top, circle the trajectory 1-5 that best describes the path of the marble after leaving the tube?

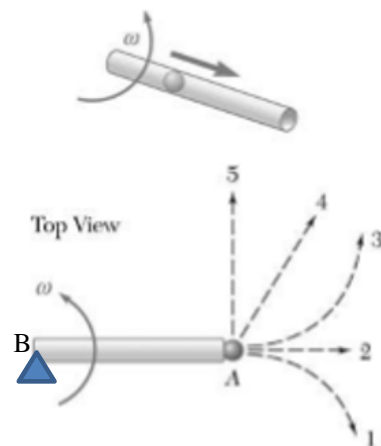

ME 240 / EMA 202, Fall 2016

Name: _____

Midterm #1, closed book/notes, 90 min.

Question 2 (30 points)

The block has a mass $M = 0.8\text{ kg}$ and moves within the smooth vertical slot. It starts from rest when the **attached** spring is in the un-stretched position at A.

Determine the *constant* vertical force \mathbf{F} which must be applied to the cord so that the block attains a speed $V_B = 2.5\text{ m/s}$ when it reaches $S_B = 0.15\text{ m}$. Note that the spring is still attached to the block at position B.

Given:

$M = 0.8\text{ kg}$	$l = 0.4\text{ m}$	$V_B = 2.5\text{ m/s}$
$b = 0.3\text{ m}$	$S_B = 0.15\text{ m}$	$k = 100\text{ N/m}$

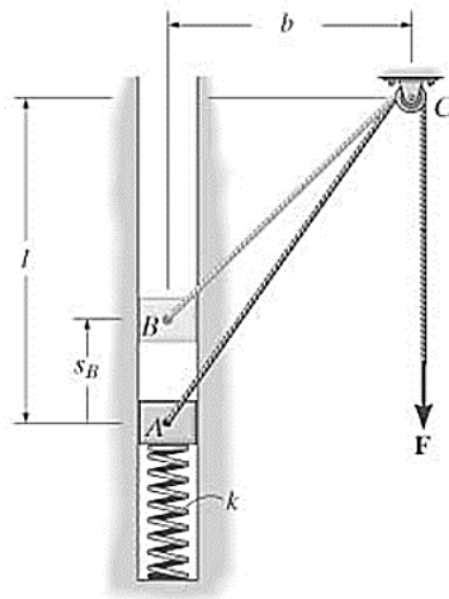

ME 240 / EMA 202, Fall 2016
Midterm #1, closed book/notes, 90 min.

Name: _____

Question 3 (30 points)

The train in the figure is supported by magnetic repulsion forces exerted in the direction perpendicular to the track. Motion of the train in the transverse direction is prevented by lateral supports. The 20,000-kg train is traveling at 30 m/s on a curved segment of track described by the equation $y = .0033x^2$ where x and y are in meters. The bank angle of the track is 40° when $x=0$. When the train is at this point in the curve:

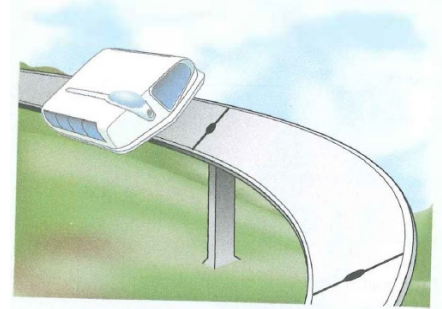

a) Draw the forces acting on the train in the outline below.

c) What force must the magnetic levitation system exert to support the train **and** what force is exerted by the lateral supports?

b) For what speed would the lateral force at this point of the curve be zero? (This is the optimum speed for the train to travel on the banked track. If you were a passenger, you would not need to exert any lateral force to remain in place in your seat.)

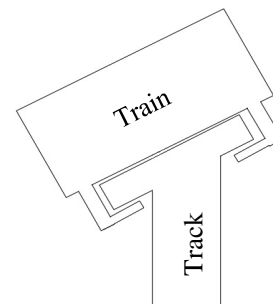

ME 240 / EMA 202, Fall 2016

Name: _____

Midterm #1, closed book/notes, 90 min.

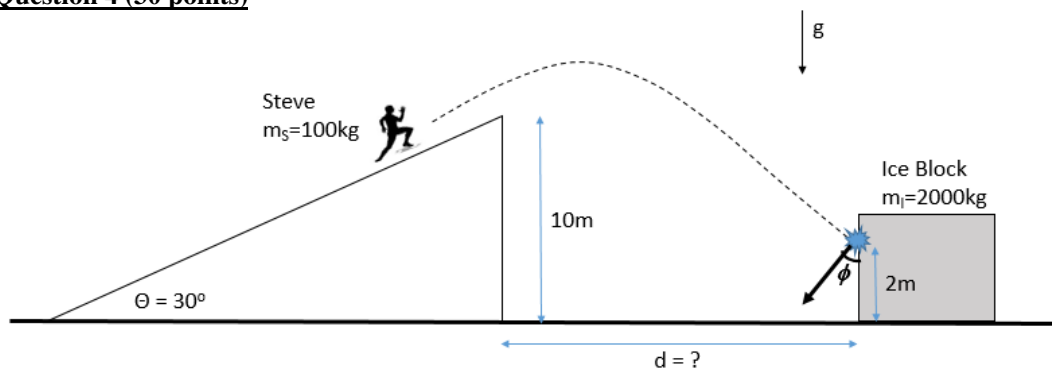
Question 4 (30 points)

For an amazing stunt, Steve runs off a 10m tall ramp with a 30° incline at a speed of 10m/s. He hopes to jump over a pit and impact a block of ice at a height of 2m.

- At what distance, d , should the ice block be placed from the end of the ramp?
- Assume that the 2000 kg ice block slides without friction on the ground. Given the coefficient of restitution between Steve and the ice block is 0.2, at what angle ϕ will Steve bounce off of the wall?
- Given that the impact between Steve and the ice block takes 0.25 seconds. What is the average force felt by Steve during the impact?

ME 240 / EMA 202, Fall 2016
Midterm #1, closed book/notes, 90 min.

Name: _____

Geometry:

$$\frac{A}{\sin a} = \frac{B}{\sin b} = \frac{C}{\sin c}$$

$$C^2 = A^2 + B^2 - 2AB \cos c$$

$$\cos^2 \theta + \sin^2 \theta = 1$$

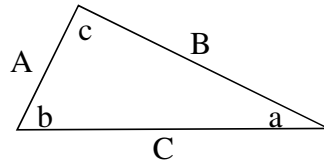

Particle Rectilinear Motion:

$$a = \frac{dv}{dt} \quad v = \frac{ds}{dt} \quad ads = vdv$$

For the special case of constant acceleration (a_c), and assuming initial conditions are specified at $t = 0$:

$$v(t) = v_o + a_c t \quad s(t) = s_o + v_o t + \frac{1}{2} a_c t^2 \quad v^2 = v_o^2 + 2a_c (s - s_o)$$

Particle Curvilinear Motion:

$$\text{Cartesian Results: } \vec{v} = \dot{x}\hat{i} + \dot{y}\hat{j} + \dot{z}\hat{k} \quad \vec{a} = \ddot{x}\hat{i} + \ddot{y}\hat{j} + \ddot{z}\hat{k}$$

Normal/Tangential Results:

$$\vec{v} = s\hat{u}_t$$

$$\vec{a} = \dot{v}\hat{u}_t + \frac{v^2}{\rho}\hat{u}_n \quad \text{where } \rho = \frac{[1 + (dy/dx)^2]^{3/2}}{|d^2y/dx^2|}$$

Polar Results:

$$\vec{v} = \dot{r}\hat{u}_r + r\dot{\theta}\hat{u}_\theta$$

$$\vec{a} = (\ddot{r} - r\dot{\theta}^2)\hat{u}_r + (r\ddot{\theta} + 2\dot{r}\dot{\theta})\hat{u}_\theta$$

Spherical Results:

$$\vec{v} = \dot{r}\hat{u}_r + r\dot{\phi}\hat{u}_\phi + r\dot{\theta}\sin\phi\hat{u}_\theta$$

$$\vec{a} = (\ddot{r} - r\dot{\phi}^2 - r\dot{\theta}^2\sin^2\phi)\hat{u}_r + (r\ddot{\phi} + 2\dot{r}\dot{\phi} - r\dot{\theta}^2\sin\phi\cos\phi)\hat{u}_\phi + (r\ddot{\theta}\sin\phi + 2\dot{r}\dot{\theta}\sin\phi + 2r\dot{\phi}\dot{\theta}\cos\phi)\hat{u}_\theta$$

General Time Derivatives of a Vector:

$$\dot{\hat{u}}(t) = \vec{\omega}_u \times \hat{u}$$

$$\dot{\vec{A}}(t) = \dot{A}\hat{u}_A + \vec{\omega}_A \times \vec{A}$$

$$\ddot{\vec{A}}(t) = \ddot{A}\hat{u}_A + 2\vec{\omega}_A \times \dot{A}\hat{u}_A + \dot{\vec{\omega}}_A \times \vec{A} + \vec{\omega}_A \times (\vec{\omega}_A \times \vec{A})$$

Principle of Work and Energy: $\Sigma U_{1 \rightarrow 2} = T_2 - T_1$ where $U_{1 \rightarrow 2} = \int_1^2 \vec{F} \cdot d\vec{r}$ and $T = \frac{1}{2}mv^2$

Conservation of Energy (assumes only conservative forces): $T_1 + V_1 = T_2 + V_2$

(For rigid bodies, these results are unchanged except for the fact that $T = \frac{1}{2}mv_G^2 + \frac{1}{2}I_G\omega^2$)

ME 240 / EMA 202, Fall 2016

Name: _____

Midterm #1, closed book/notes, 90 min.

V is potential energy and takes different forms depending on the source. For terrestrial gravity, $V = mgy$, (mgy_G for a rigid body) while for a linear elastic spring, $V = \frac{1}{2}k\delta^2$

Power: $P = \vec{F} \cdot \vec{v}$ Efficiency: $\varepsilon = \frac{\text{power output}}{\text{power input}}$ Linear Impulse and Momentum: $\sum \bar{I}_{1 \rightarrow 2} = \bar{p}_2 - \bar{p}_1$ where $\bar{I}_{1 \rightarrow 2} = \int_1^2 \bar{F} dt$ and $\bar{p} = m\vec{v}$ (For rigid bodies, the linear impulse and momentum expressions are identical but with $\vec{v} = \vec{v}_G$)Coefficient of restitution: $e = \frac{(v_B)_2 - (v_A)_2}{(v_A)_1 - (v_B)_1}$ Principle of Angular Impulse and Momentum: $\sum \bar{I}_{M 1 \rightarrow 2} = \bar{H}_{O2} - \bar{H}_{O1}$ where $\bar{I}_{M 1 \rightarrow 2} = \int_1^2 \bar{M}_O dt$ and $\bar{H} = \vec{r} \times m\vec{v}$ (For rigid bodies, this principle holds as long as O is either the center of gravity G or a point of fixed rotation. If the center of gravity, $H_G = I_G \alpha$; if a fixed axis, $H_O = I_O \omega$)

Relative General Plane Motion:

Translating Axes: $\vec{v}_B = \vec{v}_A + \vec{v}_{B/A} = \vec{v}_A + \vec{\omega} \times \vec{r}_{B/A}$
 $\vec{a}_B = \vec{a}_A + \vec{a}_{B/A} = \vec{a}_A + \vec{\alpha} \times \vec{r}_{B/A} - \omega^2 \vec{r}_{B/A}$

Rotating Axes: $\vec{v}_B = \vec{v}_A + (\vec{v}_{B/A})_{xy} + \vec{\Omega} \times \vec{r}_{B/A}$
 $\vec{a}_B = \vec{a}_A + (\vec{a}_{B/A})_{xy} + \dot{\vec{\Omega}} \times \vec{r}_{B/A} + \vec{\Omega} \times (\vec{\Omega} \times \vec{r}_{B/A}) + 2\vec{\Omega} \times (\vec{v}_{B/A})_{xy}$

Equations of Motion: $\sum F_x = m(a_G)_x$; $\sum F_y = m(a_G)_y$
 or $\sum F_t = m(a_G)_t$; $\sum F_n = m(a_G)_n$

$\sum M_G = I_G \alpha$ or $\sum M_O = I_O \alpha$ or ... if you must ...
 $\sum M_P = -\bar{y}m(a_G)_x + \bar{x}m(a_G)_y + I_G \alpha$

Mass Moment of Inertia: Definition, and in terms of radius of gyration, k : $I = \int r^2 dm = k^2 m$ Parallel axis theorem: $I = I_G + md^2$

5.1.1.2 key solutions

ME 240 / EMA 202, Fall 2016
Midterm #1, closed book/notes, 90 min.

Name: Solutions

Instructions

- Show all of your work.
- To maximize opportunities for partial credit, solve problems symbolically to the extent possible and substitute numerical values at the end.
- Include free body diagrams for all equilibrium equations.
- The only notes allowed are the equations provided with this exam.
- The use of cell phones is prohibited.
- The instructors and the University of Wisconsin expect the highest standards of honesty and integrity in the academic performance of its students. It is important that the work submitted on this examination is yours and yours alone.
- Receiving or giving aid in an examination or using notes on a closed note exam will be considered cheating and will result in a grade of F and the case being reported to the Dean of Students Office.

Circle Your Discussion Section:

EMA 202	Time	TA
301	8:50	Peter Grimmer
302	9:55	Aswin Rajendram Muthukumar
303	11:00	Aswin Rajendram Muthukumar
304	12:05	Zz Riford
305	1:20	Peter Grimmer
306	2:25	Peter Grimmer
307	12:05	Aaron Wright
ME 240		
301	8:50	Jenna Lynne
302	9:55	Jenna Lynne
303	11:00	Chembian Parthiban
304	12:05	Chembian Parthiban
305	1:20	Aaron Wright
306	2:25	Zz Riford

Grading:

Q1	/10
Q2	/30
Q3	/30
Q4	/30
Total	/100

ME 240 / EMA 202, Fall 2016
 Midterm #1, closed book/notes, 90 min.

Name: _____

Question 1 (10 points)

For the following short answer problems, please include any relevant calculations and/or a brief explanation for your answer.

1A (5 points)

A block is traveling with a speed v_0 on a smooth surface when the surface suddenly becomes rough with a coefficient of friction of μ causing the block to stop after a distance d . If the block were traveling twice as fast ($2v_0$), how far will it travel on the rough surface before stopping?

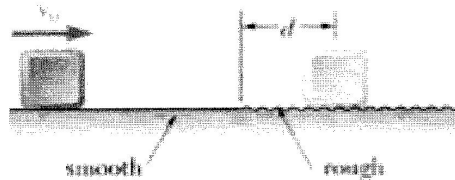

Work-Energy

$$T_1 + U_{12} = T_2 \quad v_2 = 0$$

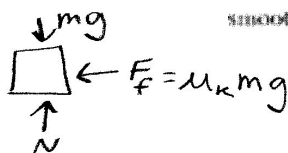

$$\frac{1}{2} m v_1^2 - F_f d = 0$$

$$\frac{1}{2} m v_1^2 - \mu_k m g d = 0 \Rightarrow d = \frac{v^2}{2\mu_k g}$$

1B (5 points)

Marble A is placed in a hollow tube that is pinned at point B. The tube is swung in a horizontal plane causing the marble to be thrown from the end of the tube. As viewed from the top, circle the trajectory 1-5 that best describes the path of the marble after leaving the tube?

Sliding distance is a function of $v^2 \therefore 2v_0 \rightarrow 4d$ sliding distance

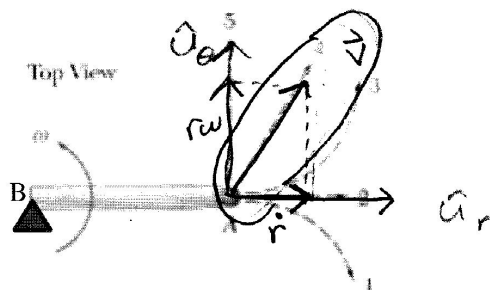
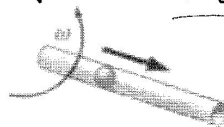

polar coordinates

$$\vec{v} = \dot{r} \hat{a}_r + r\omega \hat{a}_\theta$$

ball traveling down tube
 tube rotating

ME 240 / EMA 202, Fall 2016
Midterm #1, closed book/notes, 90 min.

Name: _____

Question 2 (30 points)

The block has a mass $M = 0.8\text{ kg}$ and moves within the smooth vertical slot. It starts from rest when the attached spring is in the un-stretched position at A.

Determine the *constant* vertical force F which must be applied to the cord so that the block attains a speed $V_B = 2.5\text{ m/s}$ when it reaches $S_B = 0.15\text{ m}$. Note that the spring is still attached to the block at position B.

Given:

$$\begin{array}{lll} M = 0.8\text{ kg} & l = 0.4\text{ m} & V_B = 2.5\text{ m/s} \\ b = 0.3\text{ m} & S_B = 0.15\text{ m} & k = 100\text{ N/m} \end{array}$$

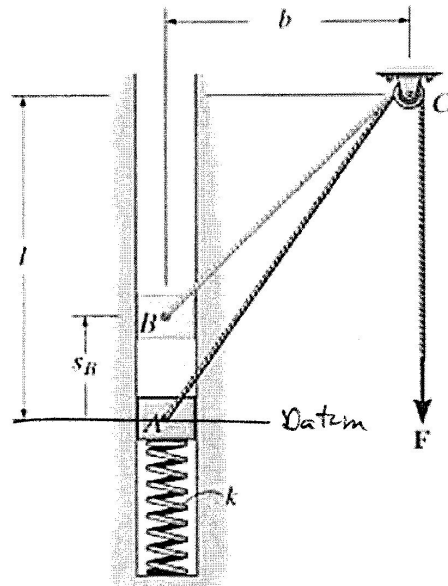

Work - Energy

$$T_1 + V_1 + U_{12} = T_2 + V_2$$

$0, @ \text{rest}$ $0, @ \text{datum}$

$$T_2 = \frac{1}{2} m V_2^2$$

$$V_2 = V_{2g} + V_{2s} = mg S_B + \frac{1}{2} k S_B^2$$

$$U_{12} = \int_1^2 \vec{F} \cdot d\vec{r} = \int_0^{S_B} F_y dy = \int_0^{S_B} F \sin \theta dy$$

$$\sin \theta = \frac{(L - y)}{\sqrt{(L - y)^2 + b^2}}$$

$$U_{12} = \int_0^{S_B} F \frac{(L - y)}{\sqrt{(L - y)^2 + b^2}} dy$$

$$u = (L - y)^2 + b^2$$

$$du = -2(L - y) dy$$

$$u_0 = L^2 + b^2$$

$$u_f = (L - S_B)^2 + b^2$$

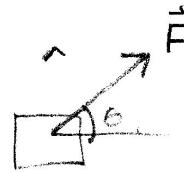

Q.2 page 2

$$U_{12} = \frac{-F}{2} \int_{L^2+b^2}^{(L-s_B)^2+b^2} \frac{du}{\sqrt{u}} = \frac{-F}{2} \frac{\sqrt{u}}{\frac{1}{2}}$$

$$U_{12} = -F \left[\sqrt{(L-s_B)^2+b^2} - \sqrt{L^2+b^2} \right]$$

$$U_{12} = F \left[\sqrt{L^2+b^2} - \sqrt{(L-s_B)^2+b^2} \right] = F \Delta L =$$

Back to W-E

$$F \Delta L = \frac{1}{2} m v_2^2 + mg s_0 + \frac{1}{2} k s_B^2$$

$$F = \frac{\frac{1}{2} (.8 \text{ kg})(2.5 \text{ m/s})^2 + .8 \text{ kg}(9.81 \text{ m/s}^2)(.15 \text{ m}) + \frac{1}{2} (100 \text{ N/m})(.15 \text{ m})^2}{0.1095 \text{ m}}$$

$$F = 43.9 \text{ N}$$

ME 240 / EMA 202, Fall 2016

Name: _____

Midterm #1, closed book/notes, 90 min.

Question 3 (30 points)

The train in the figure is supported by magnetic repulsion forces exerted in the direction perpendicular to the track. Motion of the train in the transverse direction is prevented by lateral supports. The 20,000-kg train is traveling at 30 m/s on a curved segment of track described by the equation $y = .0033x^2$ where x and y are in meters. The bank angle of the track is 40° when $x=0$. When the train is at this point in the curve:

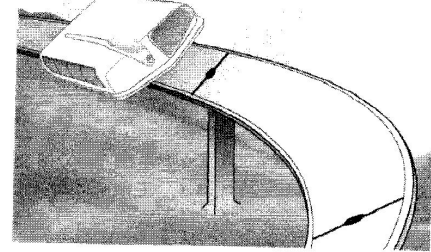

a) Draw the forces acting on the train in the outline below.

c) What force must the magnetic levitation system exert to support the train **and** what force is exerted by the lateral supports?

b) For what speed would the lateral force at this point of the curve be zero? (This is the optimum speed for the train to travel on the banked track. If you were a passenger, you would not need to exert any lateral force to remain in place in your seat.)

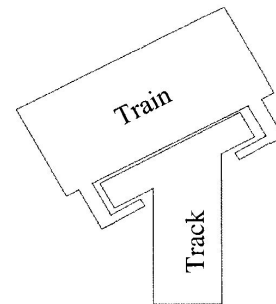

given

$$m = 20000 \text{ kg}$$

$$v = 30 \text{ m/s}$$

$$y = .0033x^2 \text{ (m)}$$

$$\theta = 40^\circ \text{ at } x=0$$

$$\rho? \rightarrow \rho = \frac{(1 + (\frac{dy}{dx})^2)^{3/2}}{\frac{d^2y}{dx^2}} = \frac{(1 + (.0066x)^2)^{3/2}}{.0066} \text{ m}$$

$$\rho(x=0) = \frac{1}{.0066} = 151,52 \text{ m}$$

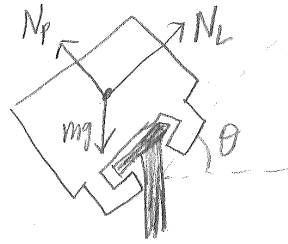

P = perpendicular
L = longitudinal

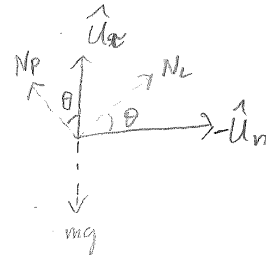

$$\sum F_x: N_p \cos \theta + N_L \sin \theta - mg = 0$$

$$\sum F_n: N_p \sin \theta - N_L \cos \theta = m \frac{v^2}{\rho}$$

$$N_L = \frac{mg - N_p \cos \theta}{\sin \theta}$$

$$N_p \sin \theta - \frac{mg - N_p \cos \theta}{\sin \theta} \cos \theta = m \frac{v^2}{\rho}$$

$$\vec{N}_p = \frac{m \frac{v^2}{\rho} + mg \cot \theta}{\sin \theta + \cot \theta \cos \theta} = 2,866 \times 10^5 \text{ N}$$

$$= \boxed{286,58 \text{ kN}}$$

$$\vec{N}_L = -36610,9 \text{ N}$$

$$= -36,61 \text{ kN}$$

$$\boxed{N_L = 36,61 \text{ kN}}$$

c) $N_L = 0$

$$N_p \sin \theta - 0 = m \frac{v^2}{\rho}$$

$$N_p \cos \theta + 0 - mg = 0$$

$$N_p = \frac{mg}{\cos \theta}$$

$$v = \sqrt{\frac{mg \rho \tan \theta}{m}}$$

$$\boxed{v = 35,30 \frac{\text{m}}{\text{s}}}$$

ME 240 / EMA 202, Fall 2016
Midterm #1, closed book/notes, 90 min.

Name: _____

Question 4 (30 points)

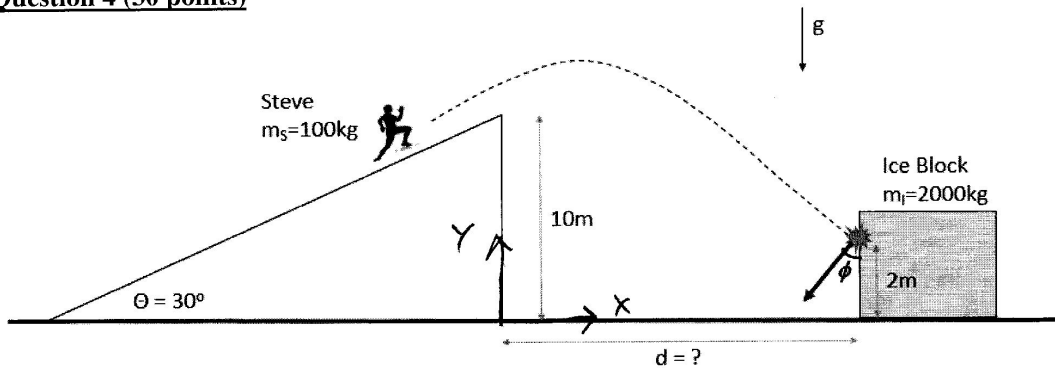

For an amazing stunt, Steve runs off a 10m tall ramp with a 30° incline at a speed of 10m/s . He hopes to jump over a pit and impact a block of ice at a height of 2m .

- At what distance, d , should the ice block be placed from the end of the ramp?
- Assume that the 2000kg ice block slides without friction on the ground. Given the coefficient of restitution between Steve and the ice block is 0.2 , at what angle ϕ will Steve bounce off of the wall?
- Given that the impact between Steve and the ice block takes 0.25 seconds. What is the average force felt by Steve during the impact?

given

$$x_0 = 0$$

$$y_0 = 10\text{m}$$

$$x_f = d$$

$$y_f = 2\text{m}$$

$$\theta = 30^\circ$$

$$v_0 = 10\text{m/s}$$

A) x -dir

$$a_x = 0$$

$$v_x = v_0 \cos \theta$$

$$x(t) = v_0 \cos \theta t + x_0$$

$$\textcircled{1} t = \frac{x}{v_0 \cos \theta}$$

y -dir

$$a_y = -g$$

$$v_y = -gt + v_0 \sin \theta$$

$$\textcircled{2} y(t) = -\frac{g}{2} t^2 + v_0 \sin \theta t + y_0$$

Sub. $\textcircled{1}$ into $\textcircled{2}$

$$y_f = -\frac{g}{2} \left(\frac{x}{v_0 \cos \theta} \right)^2 + v_0 \sin \theta \left(\frac{x}{v_0 \cos \theta} \right) + y_0$$

$$0 = \frac{-9.81\text{m/s}^2}{2} \left(\frac{x^2}{(10\text{m/s})^2 \cos^2(30^\circ)} \right) + \tan(30^\circ) x + (10\text{m} - 2\text{m})$$

$$\boxed{x = d = 16.32\text{m}}$$

Q4 Page 2

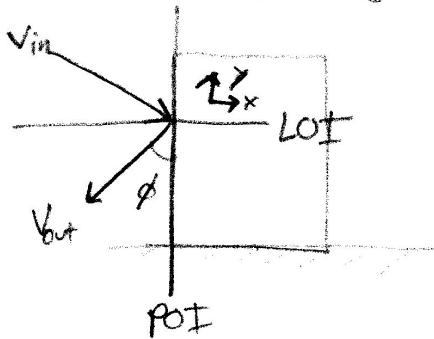
B) Find ϕ given $e = .2$, $m_S = 100\text{kg}$, $m_I = 2000\text{kg}$ 

$$\vec{v}_{in} = v_{x_f} \hat{i} + v_{y_f} \hat{j}$$

$$\vec{v}_{in} = v_0 \cos \theta \hat{i} + (-gt + v_0 \sin \theta) \hat{j}$$

$$\text{From eq (1)} \quad t = \frac{x}{v_0 \cos \theta} = \frac{16.32\text{m}}{10\text{m/s} \cos 30}$$

$$t = 1.88 \text{ sec}$$

$$\vec{v}_{in} = 10\text{m/s} \cos 30^\circ \hat{i} + [-9.81\text{m/s}^2 (1.88\text{sec}) + 10\text{m/s} \sin 30^\circ] \hat{j}$$

$$\vec{v}_{in} = 8.66\text{m/s} \hat{i} - 13.44\text{m/s} \hat{j} \Rightarrow v_x^- = 8.66\text{m/s} \quad v_y^- = -13.44\text{m/s}$$

Plane of impact direction - particle conservation of momentum

$$v_y^- = v_y^+ = -13.44\text{m/s}$$

Line of impact - system momentum & coef. of restitution
0, Ice not moving

$$m_S v_{sx}^- + m_I v_{Ix}^- = m_S v_{sx}^+ + m_I v_{Ix}^+$$

$$e = \frac{v_{Ix}^+ - v_{sx}^+}{v_{sx}^- - v_{Ix}^-} \Rightarrow v_{Ix}^+ = e v_{sx}^- + v_{sx}^+$$

$$m_S v_{sx}^- = m_S v_{sx}^+ + m_I (e v_{sx}^- + v_{sx}^+)$$

$$m_S v_{sx}^- - m_I e v_{sx}^- = (m_S + m_I) v_{sx}^+$$

$$v_{sx}^+ = \frac{(m_S - m_I e)}{m_S + m_I} v_{sx}^- = \frac{(100\text{kg} - 2000\text{kg}(.2))}{100 + 2000\text{kg}} (8.66\text{m/s})$$

$$v_{sx}^+ = -1.24\text{m/s}$$

Q4 page 3

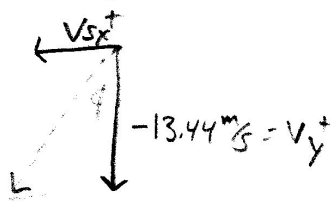
Find angle ϕ 

$$\tan \phi = \frac{V_{sx}^+}{V_{sy}^+} = \frac{1.24}{13.44}$$

$$\phi = 5.27^\circ$$

c) Force = ? if impact takes 0.25 sec.

Impulse - momentum x-direction

$$m_s V_{sx}^- + I_x = m_s V_{sx}^+$$

$$I_x = m_s (V_{sx}^+ - V_{sx}^-) = 100 \text{ kg} (-1.24 \text{ m/s} - 8.66 \text{ m/s})$$

$$I_x = -990 \text{ N}\cdot\text{s}$$

$$I_x = F_{\text{ave}} t = -990 \text{ N}\cdot\text{s}$$

$$F_{\text{ave}} = \frac{-990 \text{ N}\cdot\text{s}}{0.25 \text{ s}}$$

$$\vec{F}_{\text{ave}} = -3960 \text{ N} \uparrow$$

5.1.2 Spring 2015**5.1.2.1 exam questions****EMA 202, Spring 2015****Midterm #1, closed book/notes, 90 min.****Name:** _____**Instructions**

- Write your name on every sheet.
- Show all of your work.
- To maximize opportunities for partial credit, solve problems symbolically to the extent possible and substitute numerical values at the end.
- Include free body diagrams for all equilibrium equations.
- This is a closed book examination.
- The only notes allowed are the equations provided with this exam.
- Calculators are allowed.
- The use of cell phones is prohibited.
- The instructors and the University of Wisconsin expect the highest standards of honesty and integrity in the academic performance of its students. It is important that the work submitted on this examination is yours and yours alone.
- Receiving or giving aid in an examination or using notes on a closed note exam will be considered cheating and will result in a grade of F and the case being reported to the Dean of Students Office.

Circle Your Discussion Section:

301 (Tu 1:20, Harsha)
 302 (Tu 2:25, Harsha)
 303 (W 3:30, David)
 304 (Th 8:50, David)
 305 (Th 12:05, David)
 306 (Th 1:20, David)

Grading:

Q1	/10
Q2	/30
Q3	/30
Q4	/30
Total	/100

EMA 202, Spring 2015

Name: _____

Midterm #1, closed book/notes, 90 min.

Question 1 (10 points)

1A (4 points) A child walks across a merry-go-round with constant speed u relative to the platform. The merry-go-round is rotating about its center at a constant angular velocity, ω , in the direction shown. When the child is at the center of the platform, write an expression for the acceleration vector and note all of the terms that are equal to zero. Additionally, draw the acceleration vector (with coordinate system) at the instant shown on the figure below.

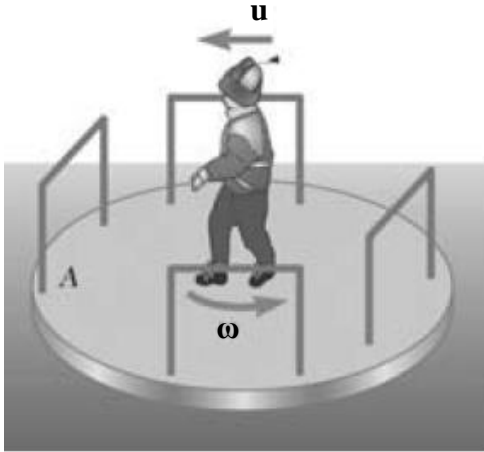
**1B (6 points)**

A 500kg elevator starts from rest and travels upward with a constant acceleration of 2m/s^2 . Determine the power output of motor M at $t = 3$ seconds.

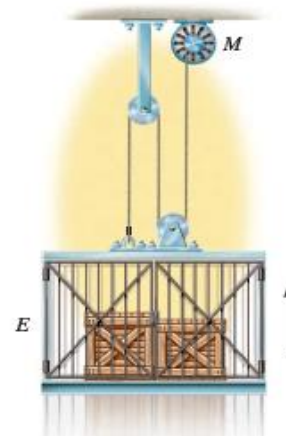

EMA 202, Spring 2015

Name: _____

Midterm #1, closed book/notes, 90 min.

Question 2 (30 points)

At the bottom of a loop in the vertical plane, an airplane has a horizontal velocity of 315mph and is accelerating at a rate of 10 ft/s^2 . The radius of curvature of the loop is 1 mile. The plane is being tracked by radar at O. What are the values for \dot{r} , \ddot{r} , $\dot{\theta}$, and $\ddot{\theta}$ at this instant?

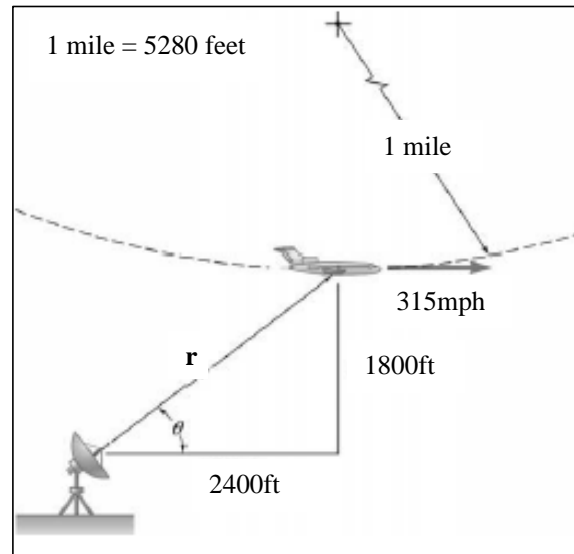

EMA 202, Spring 2015

Name: _____

Midterm #1, closed book/notes, 90 min.

Question 3 (30 points)

Each of the two blocks has mass m . The coefficient of kinetic friction on all surfaces of contact is μ . If a horizontal force P moves the bottom block, determine the acceleration of the bottom block in cases (a) and (b).

Additionally, solve for the force P , in which case (a) and (b) have the same acceleration.

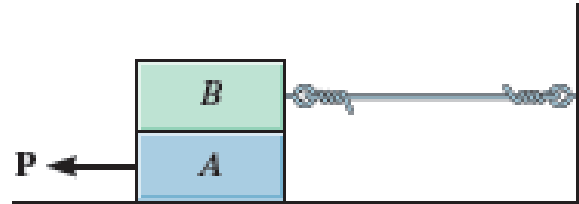

(a)

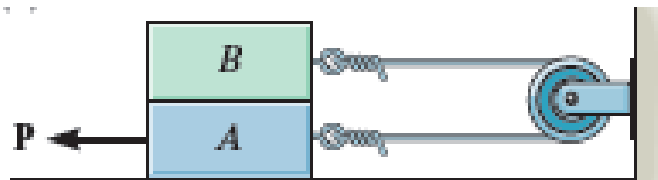

(b)

EMA 202, Spring 2015
Midterm #1, closed book/notes, 90 min.

Name: _____

Question 4 (30 points)

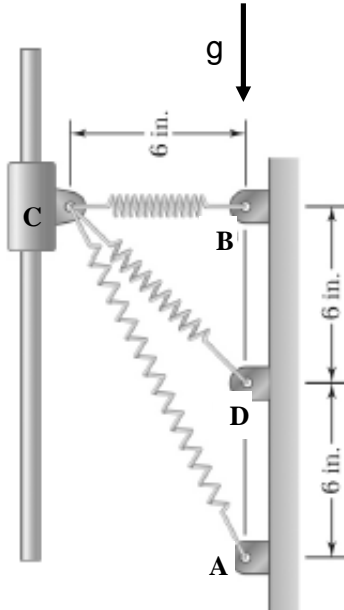

A 3-lb collar C may slide without friction along the vertical rod. It is attached to 3 springs, each with spring constant $k = 2$ lb/in and an undeformed length of 6 inches. Given that the collar is released from rest, determine the speed of the collar after it has traveled 6 inches down.

EMA 202, Spring 2015

Name: _____

Midterm #1, closed book/notes, 90 min.

Geometry:

$$\frac{A}{\sin a} = \frac{B}{\sin b} = \frac{C}{\sin c}$$

$$C^2 = A^2 + B^2 - 2AB \cos c$$

$$\cos^2 \theta + \sin^2 \theta = 1$$

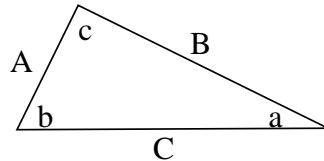

Particle Rectilinear Motion:

$$a = \frac{dv}{dt} \quad v = \frac{ds}{dt} \quad ads = vdv$$

For the special case of constant acceleration (a_c), and assuming initial conditions are specified at $t = 0$:

$$v(t) = v_o + a_c t \quad s(t) = s_o + v_o t + \frac{1}{2} a_c t^2 \quad v^2 = v_o^2 + 2a_c (s - s_o)$$

Particle Curvilinear Motion:

$$\text{Cartesian Results: } \vec{v} = \dot{x}\hat{i} + \dot{y}\hat{j} + \dot{z}\hat{k} \quad \vec{a} = \ddot{x}\hat{i} + \ddot{y}\hat{j} + \ddot{z}\hat{k}$$

Normal/Tangential Results:

$$\vec{v} = \dot{s}\hat{u}_t$$

$$\vec{a} = \dot{v}\hat{u}_t + \frac{v^2}{\rho}\hat{u}_n \quad \text{where } \rho = \frac{[1 + (dy/dx)^2]^{3/2}}{|d^2y/dx^2|}$$

Polar Results:

$$\vec{v} = \dot{r}\hat{u}_r + r\dot{\theta}\hat{u}_\theta$$

$$\vec{a} = (\ddot{r} - r\dot{\theta}^2)\hat{u}_r + (r\ddot{\theta} + 2\dot{r}\dot{\theta})\hat{u}_\theta$$

Spherical Results:

$$\vec{v} = \dot{r}\hat{u}_r + r\dot{\phi}\hat{u}_\phi + r\dot{\theta}\sin\phi\hat{u}_\theta$$

$$\vec{a} = (\ddot{r} - r\dot{\phi}^2 - r\dot{\theta}^2\sin^2\phi)\hat{u}_r + (r\ddot{\phi} + 2\dot{r}\dot{\phi} - r\dot{\theta}^2\sin\phi\cos\phi)\hat{u}_\phi + (r\ddot{\theta}\sin\phi + 2\dot{r}\dot{\theta}\sin\phi + 2r\dot{\phi}\dot{\theta}\cos\phi)\hat{u}_\theta$$

General Time Derivatives of a Vector:

$$\dot{\hat{u}}(t) = \vec{\omega}_u \times \hat{u}$$

$$\dot{\vec{A}}(t) = \dot{A}\hat{u}_A + \vec{\omega}_A \times \vec{A}$$

$$\ddot{\vec{A}}(t) = \ddot{A}\hat{u}_A + 2\vec{\omega}_A \times \dot{A}\hat{u}_A + \dot{\vec{\omega}}_A \times \vec{A} + \vec{\omega}_A \times (\vec{\omega}_A \times \vec{A})$$

Principle of Work and Energy: $\Sigma U_{1 \rightarrow 2} = T_2 - T_1$ where $U_{1 \rightarrow 2} = \int_1^2 \vec{F} \cdot d\vec{r}$ and $T = \frac{1}{2}mv^2$ Conservation of Energy (assumes only conservative forces): $T_1 + V_1 = T_2 + V_2$ (For rigid bodies, these results are unchanged except for the fact that $T = \frac{1}{2}mv_G^2 + \frac{1}{2}I_G\omega^2$)

EMA 202, Spring 2015

Name: _____

Midterm #1, closed book/notes, 90 min.

V is potential energy and takes different forms depending on the source. For terrestrial gravity, $V = mgy$, (mgy_G for a rigid body) while for a linear elastic spring, $V = \frac{1}{2}k\delta^2$

Power: $P = \vec{F} \cdot \vec{v}$ Efficiency: $\varepsilon = \frac{\text{power output}}{\text{power input}}$ Linear Impulse and Momentum: $\sum \bar{I}_{1 \rightarrow 2} = \bar{p}_2 - \bar{p}_1$ where $\bar{I}_{1 \rightarrow 2} = \int_1^2 \bar{F} dt$ and $\bar{p} = m\vec{v}$ (For rigid bodies, the linear impulse and momentum expressions are identical but with $\vec{v} = \vec{v}_G$)Coefficient of restitution: $e = \frac{(v_B)_2 - (v_A)_2}{(v_A)_1 - (v_B)_1}$ Principle of Angular Impulse and Momentum: $\sum \bar{I}_{M1 \rightarrow 2} = \bar{H}_{O2} - \bar{H}_{O1}$ where $\bar{I}_{M1 \rightarrow 2} = \int_1^2 \bar{M}_O dt$ and $\bar{H} = \vec{r} \times m\vec{v}$ (For rigid bodies, this principle holds as long as O is either the center of gravity G or a point of fixed rotation. If the center of gravity, $H_G = I_G\omega$; if a fixed axis, $H_O = I_O\omega$.)

Relative General Plane Motion:

Translating Axes: $\vec{v}_B = \vec{v}_A + \vec{v}_{B/A} = \vec{v}_A + \vec{\omega} \times \vec{r}_{B/A}$
 $\vec{a}_B = \vec{a}_A + \vec{a}_{B/A} = \vec{a}_A + \vec{\alpha} \times \vec{r}_{B/A} - \omega^2 \vec{r}_{B/A}$

Rotating Axes: $\vec{v}_B = \vec{v}_A + (\vec{v}_{B/A})_{xy} + \vec{\Omega} \times \vec{r}_{B/A}$
 $\vec{a}_B = \vec{a}_A + (\vec{a}_{B/A})_{xy} + \dot{\vec{\Omega}} \times \vec{r}_{B/A} + \vec{\Omega} \times (\vec{\Omega} \times \vec{r}_{B/A}) + 2\vec{\Omega} \times (\vec{v}_{B/A})_{xy}$

Equations of Motion: $\sum F_x = m(a_G)_x$; $\sum F_y = m(a_G)_y$
 or $\sum F_t = m(a_G)_t$; $\sum F_n = m(a_G)_n$

$\sum M_G = I_G\alpha$ or $\sum M_O = I_O\alpha$ or ... if you must ...
 $\sum M_P = -\bar{y}m(a_G)_x + \bar{x}m(a_G)_y + I_G\alpha$

Mass Moment of Inertia: Definition, and in terms of radius of gyration, k : $I = \int r^2 dm = k^2 m$ Parallel axis theorem: $I = I_G + md^2$

5.1.2.2 key solution

EMA 202, Spring 2015

Midterm #1, closed book/notes, 90 min.

Name: _____

Question 1 (10 points)

1A (5 points) A child walks across a merry-go-round with constant speed u relative to the platform. The merry-go-round is rotating about its center at a constant angular velocity, ω , in the direction shown. When the child is at the center of the platform, write an expression for the acceleration vector and draw the acceleration vector (with coordinate system) on the figure below.

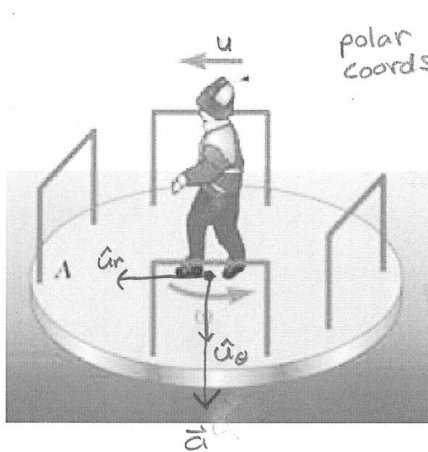
polar
coords

$$\vec{a} = (\ddot{r} - r\dot{\theta}^2)\hat{u}_r + (r\ddot{\theta} + 2\dot{r}\dot{\theta})\hat{u}_\theta$$

$$\text{given } \omega = \dot{\theta}, \text{ so } \ddot{\theta} = 0$$

$$u = \dot{r} = \dot{c}, \text{ so } \ddot{r} = 0$$

$$\text{find } \vec{a} \text{ @ } r=0$$

$$\vec{a} = (0 - 0 \cdot \omega^2)\hat{u}_r + (0 \cdot 0 + 2u\omega)\hat{u}_\theta$$

$$\boxed{\vec{a} = 2u\omega\hat{u}_\theta}$$

1B (5 points)

A 500kg elevator starts from rest and travels upward with a constant acceleration of 2m/s^2 . Determine the power output of motor M at $t = 2$ seconds.

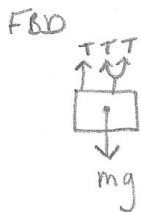

$$P = \vec{F} \cdot \vec{v}$$

$$\Sigma F_y = 3T - mg = ma_y$$

$$T = \frac{m(a_y + g)}{3}$$

$$T = \frac{500\text{kg}(2\text{m/s}^2 + 9.81\text{m/s}^2)}{3}$$

$$T = 1968.3\text{N}$$

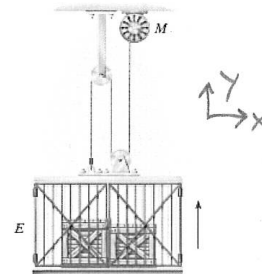

Velocity

$$v_E = v_0 + a_y t = 2\text{m/s}^2(3\text{sec})$$

$$v_E = 6\text{m/s}$$

Power

$$P = \vec{F} \cdot \vec{v} = 3T\hat{j} \cdot 6\text{m/s}\hat{j}$$

$$\boxed{P = 35.4\text{ kW}}$$

EMA 202, Spring 2015

Name: _____

Midterm #1, closed book/notes, 90 min.

Question 2 (30 points)

At the bottom of a loop in the vertical plane, an airplane has a horizontal velocity of 315 mph and is accelerating at a rate of 10 ft/s^2 . The radius of curvature of the loop is 1 mile. The plane is being tracked by radar at O. What are the values for \dot{r} , \ddot{r} , θ , and $\ddot{\theta}$ at this instant?

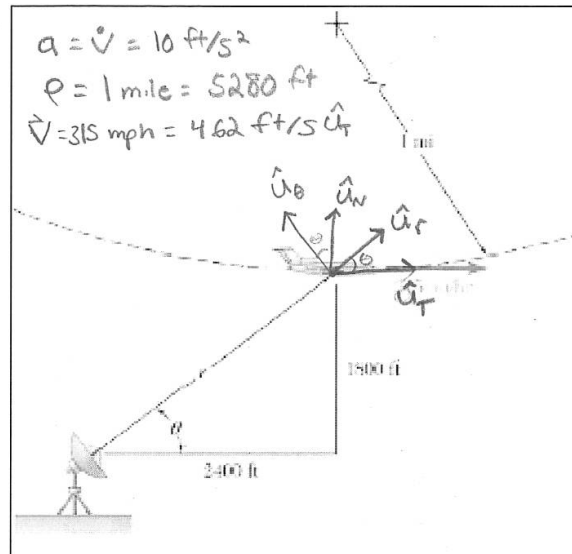

accel in $V = 315 \text{ MPH} = 462 \text{ ft/s}$
NT

$$\vec{a} = \dot{v} \hat{u}_T + \frac{v^2}{\rho} \hat{u}_N$$

$$\vec{a} = 10 \text{ ft/s}^2 \hat{u}_T + \frac{(462 \text{ ft/s})^2}{5280 \text{ ft}} \hat{u}_N$$

$$a_T = 10 \text{ ft/s}^2$$

$$a_N = 40.425 \text{ ft/s}^2$$

polar coords

$$r = \sqrt{1800^2 + 2400^2} = 3000 \text{ ft}$$

$$\theta = \tan^{-1}\left(\frac{1800}{2400}\right) = 36.9^\circ$$

$$\vec{v} = \dot{r} \hat{u}_r + r \dot{\theta} \hat{u}_\theta$$

$$\vec{a} = (\ddot{r} - r \dot{\theta}^2) \hat{u}_r + (r \ddot{\theta} + 2 \dot{r} \dot{\theta}) \hat{u}_\theta$$

convert to r, θ

$$\vec{v} = 462 \hat{u}_T = 462 \cos \theta \hat{u}_r - 462 \sin \theta \hat{u}_\theta$$

$$\vec{a} = 10 \hat{u}_T + 40.425 \hat{u}_N = 10 \cos \theta \hat{u}_r - 10 \sin \theta \hat{u}_\theta + 40.425 \sin \theta \hat{u}_r + 40.425 \cos \theta \hat{u}_\theta$$

$$\vec{a} = (10 \cos \theta + 40.425 \sin \theta) \hat{u}_r + (40.425 \cos \theta - 10 \sin \theta) \hat{u}_\theta$$

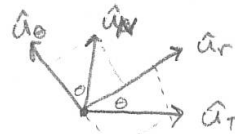

write \hat{u}_N & \hat{u}_T in terms of $\hat{u}_r, \hat{u}_\theta$

$$\hat{u}_T = \cos \theta \hat{u}_r - \sin \theta \hat{u}_\theta$$

$$\hat{u}_N = \sin \theta \hat{u}_r + \cos \theta \hat{u}_\theta$$

EMA 202, Spring 2015

Name: _____

Midterm #1, closed book/notes, 90 min.

(Additional workspace for Question 2)

$$v_r) \quad \dot{r} = 462 \cos \theta \quad w/ \quad \theta = 36.9^\circ$$

$$\dot{r} = 369.5 \text{ ft/s}$$

$$v_\theta) \quad r \dot{\theta} = -462 \sin \theta \quad w/ \quad r = 3000 \text{ ft}$$

$$\dot{\theta} = \frac{-462 \sin \theta}{r}$$

$$\dot{\theta} = -.092 \text{ r/s}$$

$$a_r) \quad \ddot{r} - r \dot{\theta}^2 = 10 \cos \theta + 40.425 \sin \theta$$

$$\ddot{r} = 10 \cos \theta + 40.425 \sin \theta + r \dot{\theta}^2$$

$$\ddot{r} = 57.7 \text{ ft/s}^2$$

$$a_\theta) \quad r \ddot{\theta} + 2 \dot{r} \dot{\theta} = 40.425 \cos \theta - 10 \sin \theta$$

$$\ddot{\theta} = \frac{1}{3000} (40.425 \cos \theta - 10 \sin \theta - 2(\dot{r})\dot{\theta})$$

$$\ddot{\theta} = .0314 \text{ r/s}^2$$

EMA 202, Spring 2015

Midterm #1, closed book/notes, 90 min.

Name: _____

Question 3 (30 points)

Each of the two blocks has a mass m . The coefficient of kinetic friction on all surfaces of contact is μ . If a horizontal force P moves the bottom block, determine the acceleration of the bottom block in cases (a) and (b).

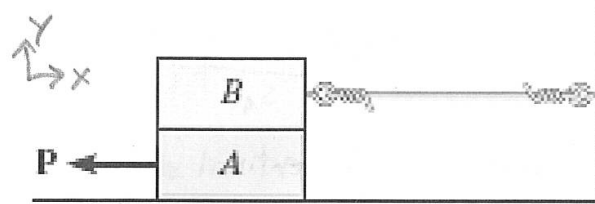

(a)

Additionally, solve for the force P , in which case (a) and (b) have the same acceleration.

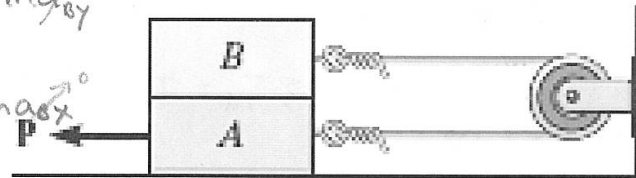
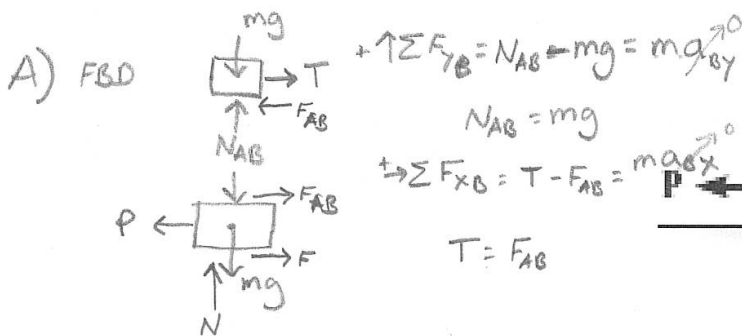

(b)

$$+\uparrow \Sigma F_{yA} = N - N_{AB} - mg = ma_{yA}^{\rightarrow 0}$$

$$N = N_{AB} + mg = 2mg$$

$$\rightarrow \Sigma F_{xA} = -P + F + F_{AB} = ma_{Ax} \quad \text{w/} \quad F = \mu N \quad \& \quad F_{AB} = \mu N_{AB}$$

$$-P + \mu N + \mu N_{AB} = ma_{Ax}$$

$$-P + \mu 2mg + \mu mg = ma_{Ax}$$

$$a_{Ax} = \frac{-P}{m} + 3\mu g$$

EMA 202, Spring 2015

Name: _____

Midterm #1, closed book/notes, 90 min.

(Additional workspace for Question 3)

B)

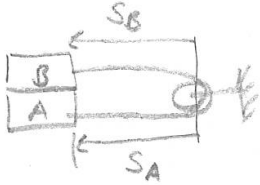

rope length

$$L = S_A + S_B$$

$$\dot{L} = 0 = v_A + v_B$$

$$\ddot{L} = 0 = a_A + a_B$$

$$a_A = -a_B$$

From part A vertical dir.

$$N = 2mg$$

$$N_{AB} = mg$$

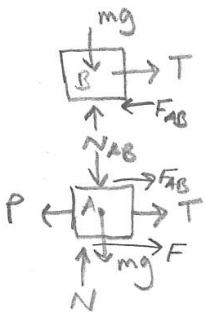

$$\sum F_{xB} = T - F_{AB} = ma_{Bx} \Rightarrow T = F_{AB} - ma_{Ax}$$

$$\sum F_{xA} = T + F_{AB} + F - P = ma_{Ax}$$

$$F_{AB} - ma_{Ax} + F_{AB} + F - P = ma_{Ax}$$

$$2F_{AB} + F - P = 2ma_{Ax} \quad \text{w/ } F = \mu N = \mu 2mg$$

$$F_{AB} = \mu N_{AB} = \mu mg$$

$$2(\mu mg) + 2\mu mg - P = 2ma_{Ax}$$

$$a_{Ax} = -\frac{P}{2m} + 2\mu g$$

C) find P so accel for (a) & (b) are equal

(a)

(b)

$$-\frac{P}{m} + 3\mu g = -\frac{P}{2m} + 2\mu g$$

$$3\mu g - 2\mu g = -\frac{P}{2m} + \frac{P}{m}$$

$$\mu g = \frac{P}{2m}$$

$$P = 2m\mu g$$

EMA 202, Spring 2015
Midterm #1, closed book/notes, 90 min.

Name: _____

Question 4 (30 points)

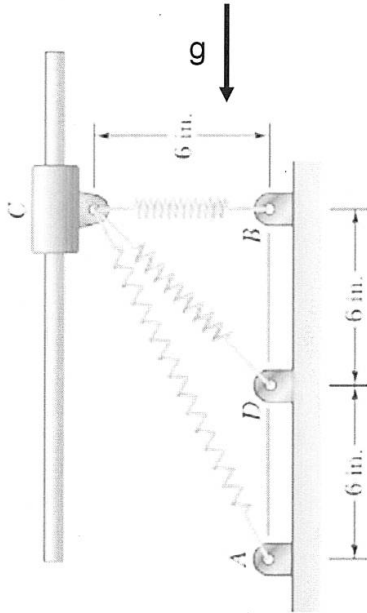

A 3-lb collar C may slide without friction along the vertical rod. It is attached to 3 springs, each with spring constant $k = 2$ lb/in and an undeformed length of 6 inches. Given that the collar is released from rest, determine the speed of the collar after it has traveled 6 inches down.

$$k = 2 \text{ lb/in} = 24 \text{ lb/ft}$$

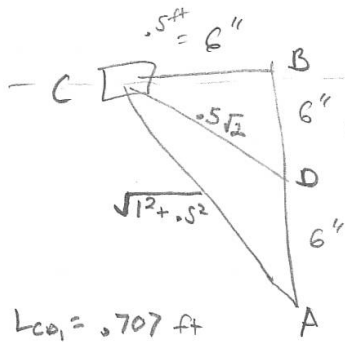

$$L_{CD} = 0.707 \text{ ft}$$

$$L_{AC} = 1.12 \text{ ft}$$

$$T_1 + V_1 = T_2 + V_2$$

$$\textcircled{1} T_1 = \frac{1}{2} m V_1^2 = 0 \text{ released from rest}$$

$$V_1 = V_{1SBC} + V_{1SDC} + V_{1SAC} + mgh = 0$$

$$V_{1SBC} = \frac{1}{2} k \delta^2 = \frac{1}{2} k (L - L_0)^2 = 0$$

$$V_{1SDC} = \frac{1}{2} k \delta^2 = \frac{1}{2} k (L_{CD} - 0.5 \text{ ft})^2 = \frac{1}{2} (24 \text{ lb/ft}) (.707 - 0.5)^2$$

$$V_{1SDC} = 0.514 \text{ ft}\cdot\text{lb}$$

$$V_{1SAC} = \frac{1}{2} k (L_{AC} - 0.5 \text{ ft})^2 = 4.613 \text{ ft}\cdot\text{lb}$$

$$V_1 = 0 + 0.514 + 4.613 \text{ ft}\cdot\text{lb} = 5.13 \text{ ft}\cdot\text{lb}$$

State 2

$$T_2 = \frac{1}{2} m V_2^2 = \frac{1}{2} \left(\frac{3 \text{ lb}}{32.2 \text{ ft/s}^2} \right) V_2^2$$

$$V_2 = V_{2SBC} + V_{2SCD} + V_{2SAC} - mgh$$

$$V_{2SBC} = V_{2SAC} = \frac{1}{2} k (.5\sqrt{2} - 0.5)^2 = 0.514 \text{ ft}\cdot\text{lb}$$

$$V_{2CD} = \frac{1}{2} k (.5 - 0.5)^2 = 0$$

$$V_2 = 2 \cdot V_{2SBC} - mgh = 2(0.514 \text{ ft}\cdot\text{lb}) - 3 \text{ lb}(.5 \text{ ft})$$

$$V_2 = -0.472 \text{ ft}\cdot\text{lb}$$

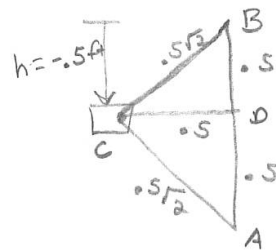

$$T_1 + V_1 = T_2 + V_2$$

$$5.13 \text{ ft}\cdot\text{lb} = \frac{1}{2} \left(\frac{3 \text{ lb}}{32.2 \text{ ft/s}^2} \right) V_2^2 + (-.472 \text{ lb}\cdot\text{ft})$$

$$V_2^2 = 120.25 \text{ ft}\cdot\text{lb}$$

$$\boxed{V_2 = 10.97 \text{ ft/s}} \downarrow$$

5.1.3 Fall 2014**5.1.3.1 exam questions****EMA 202, Fall 2014****Name:** _____**Midterm #1, closed book/notes, 90 min.****Instructions**

- Write your name on every sheet.
- Show all of your work.
- To maximize opportunities for partial credit, solve problems symbolically to the extent possible and substitute numerical values at the end.
- Include free body diagrams for all equilibrium equations.
- This is a closed book examination.
- The only notes allowed are the equations provided with this exam.
- Calculators are allowed.
- The use of cell phones is prohibited.
- The instructors and the University of Wisconsin expect the highest standards of honesty and integrity in the academic performance of its students. It is important that the work submitted on this examination is yours and yours alone.
- Receiving or giving aid in an examination or using notes on a closed note exam will be considered cheating and will result in a grade of F and the case being reported to the Dean of Students Office.

Circle Your Discussion Section:

301 (Tu 1:20, David)
 302 (Tu 2:25, David)
 303 (W 3:30, David)
 304 (Th 8:50, Matt)
 305 (Th 12:05, Matt)
 306 (Th 1:20, Matt)

Grading:

Q1	/25
Q2	/25
Q3	/25
Q4	/25
Total	/100

EMA 202, Fall 2014

Name: _____

Midterm #1, closed book/notes, 90 min.

Question 1 (25 points)

Conceptual questions: please include a few sentences or equations to justify your answers

1A (6 points) The trajectory of a particle is shown on the figure below. At point A the speed of the particle is decreasing. Draw the acceleration and velocity vectors at point A (magnitude is not important)

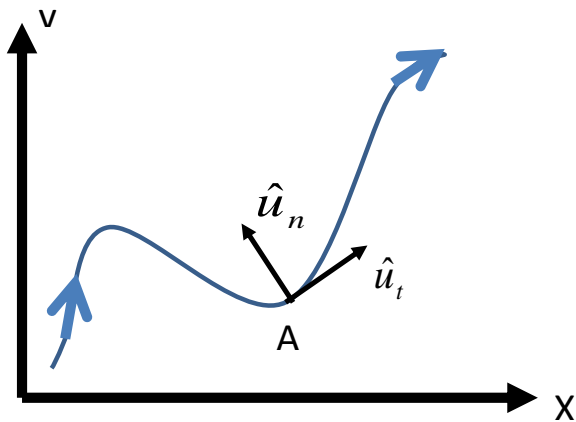

1B (5 points) A windmill sits in an inertial coordinate system. Its blades are rotating at a constant rate ω . Is the acceleration of point A equal to 0?

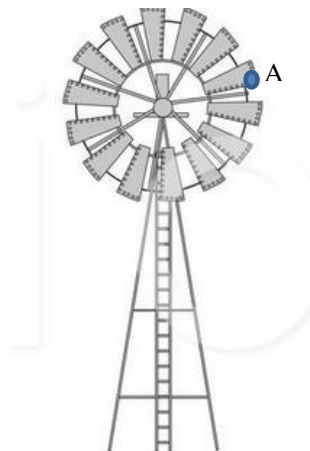

EMA 202, Fall 2014

Name: _____

Midterm #1, closed book/notes, 90 min.

1C (8 points) Determine the equation for the trajectory of a projectile, $y(x)$. Assume $x(t=0) = 0$ and $y(t=0) = 0$. (hint: your equation should look like $Y = C_1X + C_2X^2$, Find C1 and C2)



1D (6 points) A toy car is riding a track with a circular loop of radius R . What is the minimum speed that the car must be going at point A to maintain contact with the track? Let m =car mass

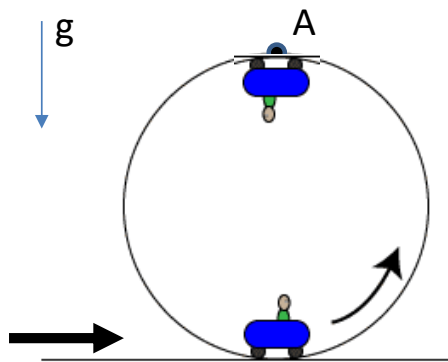

EMA 202, Fall 2014

Name: _____

Midterm #1, closed book/notes, 90 min.

Question 2 (25 points)

A ball is thrown horizontally from the top of a 20m tall building with a velocity of 10m/s. A short time later, a person on the ground (point B) throws another ball such that the two balls collide at point C. Given that the person on the ground throws from a height of 1m and an angle $\theta = 35^\circ$,

- Find the height at which the balls collide
- Find the velocity of the ball thrown from point B
- Find the time delay between when ball A and B are thrown

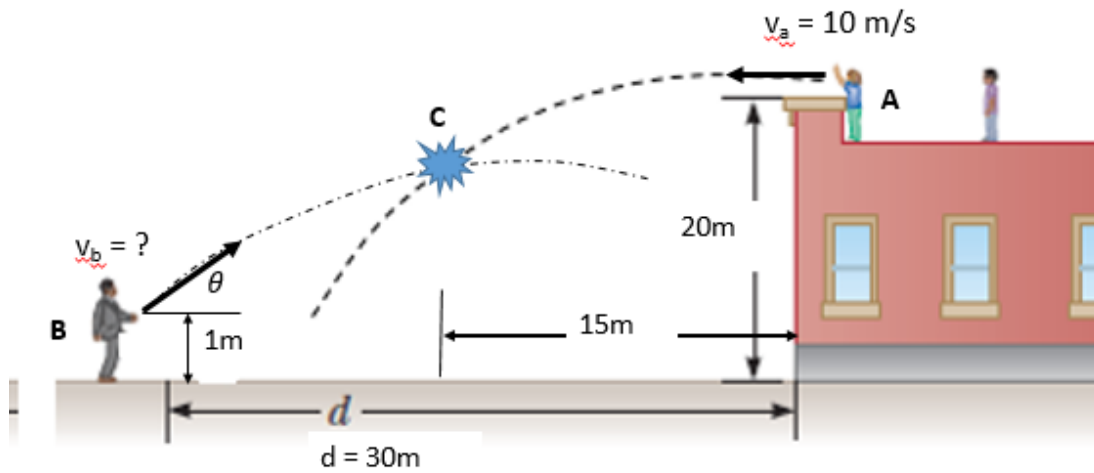

EMA 202, Fall 2014
Midterm #1, closed book/notes, 90 min.

Name: _____

Question 3 (25 points)

A 10kg mass, m , rotates around a vertical pole in a horizontal circular path with radius $R=1\text{m}$. The angles of the ropes with respect to the vertical direction are 35° and 55° .

Find the range of the velocity of the mass such that the mass will remain on the circular path described above?

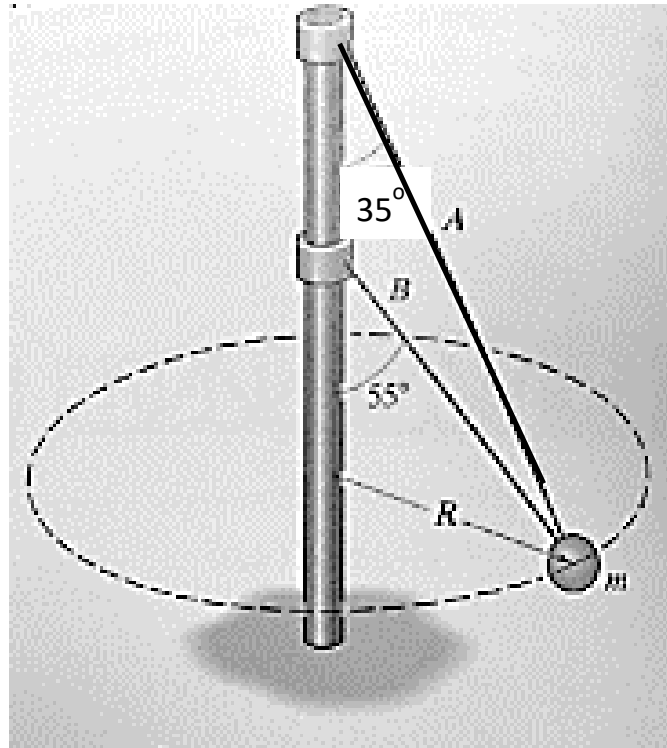

EMA 202, Fall 2014

Midterm #1, closed book/notes, 90 min.

Name: _____

Question 4 (25 points)

Crates A and B of mass 50 kg and 75 kg, respectively, are released from rest. The linear elastic spring has stiffness $k=500\text{Nm}$.

Neglect the mass of the pulleys and cables and neglect friction in the pulley bearings.

If $\mu_k=0.25$ and the spring is initially unstretched, determine the speed of B after A slides 4 m.

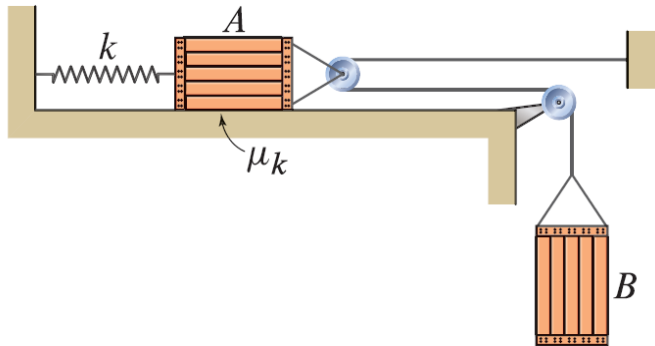

EMA 202, Fall 2014

Name: _____

Midterm #1, closed book/notes, 90 min.

Geometry:

$$\frac{A}{\sin a} = \frac{B}{\sin b} = \frac{C}{\sin c}$$

$$C^2 = A^2 + B^2 - 2AB \cos c$$

$$\cos^2 \theta + \sin^2 \theta = 1$$

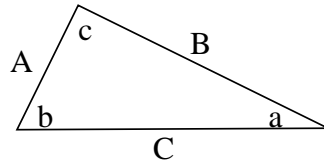

Particle Rectilinear Motion:

$$a = \frac{dv}{dt} \quad v = \frac{ds}{dt} \quad ads = vdv$$

For the special case of constant acceleration (a_c), and assuming initial conditions are specified at $t = 0$:

$$v(t) = v_o + a_c t \quad s(t) = s_o + v_o t + \frac{1}{2} a_c t^2 \quad v^2 = v_o^2 + 2a_c (s - s_o)$$

Particle Curvilinear Motion:

$$\text{Cartesian Results: } \vec{v} = \dot{x}\hat{i} + \dot{y}\hat{j} + \dot{z}\hat{k} \quad \vec{a} = \ddot{x}\hat{i} + \ddot{y}\hat{j} + \ddot{z}\hat{k}$$

Normal/Tangential Results:

$$\vec{v} = \dot{s}\hat{u}_t$$

$$\vec{a} = \dot{v}\hat{u}_t + \frac{v^2}{\rho}\hat{u}_n \quad \text{where } \rho = \frac{[1 + (dy/dx)^2]^{3/2}}{|d^2y/dx^2|}$$

Polar Results:

$$\vec{v} = \dot{r}\hat{u}_r + r\dot{\theta}\hat{u}_\theta$$

$$\vec{a} = (\ddot{r} - r\dot{\theta}^2)\hat{u}_r + (r\ddot{\theta} + 2\dot{r}\dot{\theta})\hat{u}_\theta$$

Spherical Results:

$$\vec{v} = \dot{r}\hat{u}_r + r\dot{\phi}\hat{u}_\phi + r\dot{\theta}\sin\phi\hat{u}_\theta$$

$$\vec{a} = (\ddot{r} - r\dot{\phi}^2 - r\dot{\theta}^2\sin^2\phi)\hat{u}_r + (r\ddot{\phi} + 2\dot{r}\dot{\phi} - r\dot{\theta}^2\sin\phi\cos\phi)\hat{u}_\phi + (r\ddot{\theta}\sin\phi + 2\dot{r}\dot{\theta}\sin\phi + 2r\dot{\phi}\dot{\theta}\cos\phi)\hat{u}_\theta$$

General Time Derivatives of a Vector:

$$\dot{\hat{u}}(t) = \vec{\omega}_u \times \hat{u}$$

$$\dot{\vec{A}}(t) = \dot{A}\hat{u}_A + \vec{\omega}_A \times \vec{A}$$

$$\ddot{\vec{A}}(t) = \ddot{A}\hat{u}_A + 2\vec{\omega}_A \times \dot{A}\hat{u}_A + \dot{\vec{\omega}}_A \times \vec{A} + \vec{\omega}_A \times (\vec{\omega}_A \times \vec{A})$$

Principle of Work and Energy: $\Sigma U_{1 \rightarrow 2} = T_2 - T_1$ where $U_{1 \rightarrow 2} = \int_1^2 \vec{F} \cdot d\vec{r}$ and $T = \frac{1}{2}mv^2$ Conservation of Energy (assumes only conservative forces): $T_1 + V_1 = T_2 + V_2$ (For rigid bodies, these results are unchanged except for the fact that $T = \frac{1}{2}mv_G^2 + \frac{1}{2}I_G\omega^2$)

EMA 202, Fall 2014

Name: _____

Midterm #1, closed book/notes, 90 min.

V is potential energy and takes different forms depending on the source. For terrestrial gravity, $V = mgy$, (mgy_G for a rigid body) while for a linear elastic spring, $V = \frac{1}{2}k\delta^2$

Power: $P = \vec{F} \cdot \vec{v}$ Efficiency: $\varepsilon = \frac{\text{power output}}{\text{power input}}$ Linear Impulse and Momentum: $\sum \bar{I}_{1 \rightarrow 2} = \bar{p}_2 - \bar{p}_1$ where $\bar{I}_{1 \rightarrow 2} = \int_1^2 \bar{F} dt$ and $\bar{p} = m\vec{v}$ (For rigid bodies, the linear impulse and momentum expressions are identical but with $\vec{v} = \vec{v}_G$)Coefficient of restitution: $e = \frac{(v_B)_2 - (v_A)_2}{(v_A)_1 - (v_B)_1}$ Principle of Angular Impulse and Momentum: $\sum \bar{I}_{M1 \rightarrow 2} = \bar{H}_{O2} - \bar{H}_{O1}$ where $\bar{I}_{M1 \rightarrow 2} = \int_1^2 \bar{M}_O dt$ and $\bar{H} = \vec{r} \times m\vec{v}$ (For rigid bodies, this principle holds as long as O is either the center of gravity G or a point of fixed rotation. If the center of gravity, $H_G = I_G\omega$; if a fixed axis, $H_O = I_O\omega$.)

Relative General Plane Motion:

Translating Axes: $\vec{v}_B = \vec{v}_A + \vec{v}_{B/A} = \vec{v}_A + \vec{\omega} \times \vec{r}_{B/A}$
 $\vec{a}_B = \vec{a}_A + \vec{a}_{B/A} = \vec{a}_A + \vec{\alpha} \times \vec{r}_{B/A} - \omega^2 \vec{r}_{B/A}$

Rotating Axes: $\vec{v}_B = \vec{v}_A + (\vec{v}_{B/A})_{xy} + \vec{\Omega} \times \vec{r}_{B/A}$
 $\vec{a}_B = \vec{a}_A + (\vec{a}_{B/A})_{xy} + \dot{\vec{\Omega}} \times \vec{r}_{B/A} + \vec{\Omega} \times (\vec{\Omega} \times \vec{r}_{B/A}) + 2\vec{\Omega} \times (\vec{v}_{B/A})_{xy}$

Equations of Motion: $\sum F_x = m(a_G)_x$; $\sum F_y = m(a_G)_y$
 or $\sum F_t = m(a_G)_t$; $\sum F_n = m(a_G)_n$

$\sum M_G = I_G\alpha$ or $\sum M_O = I_O\alpha$ or ... if you must ...
 $\sum M_P = -\bar{y}m(a_G)_x + \bar{x}m(a_G)_y + I_G\alpha$

Mass Moment of Inertia: Definition, and in terms of radius of gyration, k : $I = \int r^2 dm = k^2 m$ Parallel axis theorem: $I = I_G + md^2$

5.1.3.2 key answers

EMA 202, Fall 2014

Name: _____

Midterm #1, closed book/notes, 90 min.

Question 1 (25 points)

Conceptual questions: please include a few sentences or equations to justify your answers

1A (6 points) The trajectory of a particle is shown on the figure below. At point A the speed of the particle is decreasing. Draw the acceleration and velocity vectors at point A (magnitude is not important)

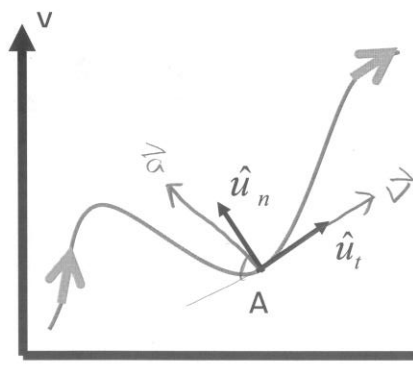

→ velocity is tangent to the path

$$\vec{a} = -a_t \hat{u}_t + a_n \hat{u}_n$$

Slowing down

3 pts for \vec{v}
3 pts for \vec{a}

1B (5 points) A windmill sits in an inertial coordinate system. Its blades are rotating at a constant rate ω . Is the acceleration of point A equal to 0?



polar

$$\vec{a} = (\ddot{r} - r\dot{\theta}^2) \hat{u}_r + (r\ddot{\theta} + 2\dot{r}\dot{\theta}) \hat{u}_\theta$$

$$\dot{r} = \ddot{r} = \ddot{\theta} = 0$$

$$\vec{a} = -r\dot{\theta}^2 \hat{u}_r \neq 0$$

centripetal acceleration is nonzero

or in N-T

$$\vec{a} = \dot{v} \hat{u}_T + \frac{v^2}{\rho} \hat{u}_n, \quad \dot{v} = 0$$

$$\vec{a} = \frac{v^2}{\rho} \hat{u}_n \neq 0$$

EMA 202, Fall 2014

Name: _____

Midterm #1, closed book/notes, 90 min.

1C (8 points) Determine the equation for the trajectory of a projectile, $y(x)$. Assume $x(t=0) = 0$ and $y(t=0) = 0$. (hint: your equation should look like $Y = C_1X + C_2X^2$, Find C_1 and C_2)

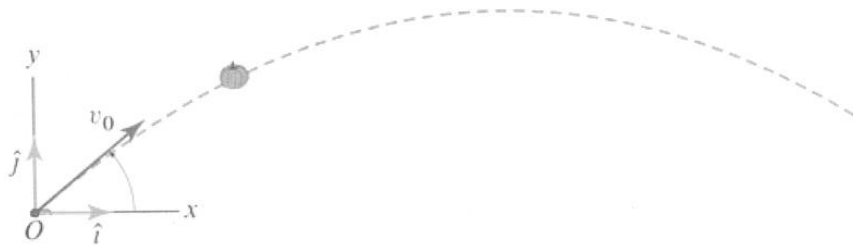

2 pts $x(t) = v_0 \cos \theta t \implies$ solve for $t(x)$ $t = \frac{x}{v_0 \cos \theta}$ (2 pts)

2 pts $y(t) = v_0 \sin \theta t - \frac{g}{2} t^2$

plug $t(x)$ into $y(t)$

$$y = v_0 \sin \theta \left(\frac{x}{v_0 \cos \theta} \right) - \frac{g}{2} \left(\frac{x}{v_0 \cos \theta} \right)^2$$

$C_1 = \tan \theta$

$C_2 = \frac{g}{2 v_0^2 \cos^2 \theta}$

2 pts $y = \tan \theta x - \left(\frac{g}{2 v_0^2 \cos^2 \theta} \right) x^2$

1D (6 points) A toy car is riding a track with a circular loop of radius R . What is the minimum speed that the car must be going at point A to maintain contact with the track? Let m =car mass

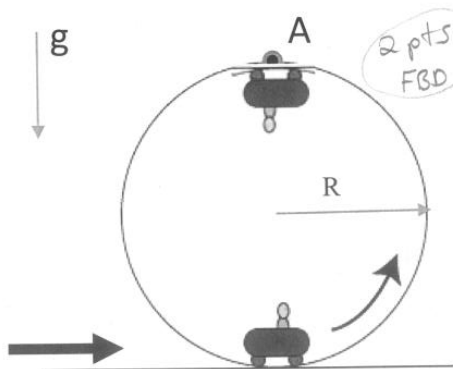

2 pts FBD



$\sum F_n = mg - N = ma_n$ (2 pts)

$a_n = \frac{v^2}{R}$

$mg = m \frac{v^2}{R}$

$v = \sqrt{gR}$ (2 pts)

EMA 202, Fall 2014

Name: _____

Midterm #1, closed book/notes, 90 min.

Question 2 (25 points)

A ball is thrown horizontally from the top of a 20m tall building with a velocity of 10m/s. A short time later, a person on the ground (point B) throws another ball such that the two balls collide at point C. Given that the person on the ground throws from a height of 1m and an angle $\theta = 35^\circ$,

8 pts
12 pts
5 pts

- Find the height at which the balls collide
- Find the velocity of the ball thrown from point B
- Find the time delay between when ball A and B are thrown

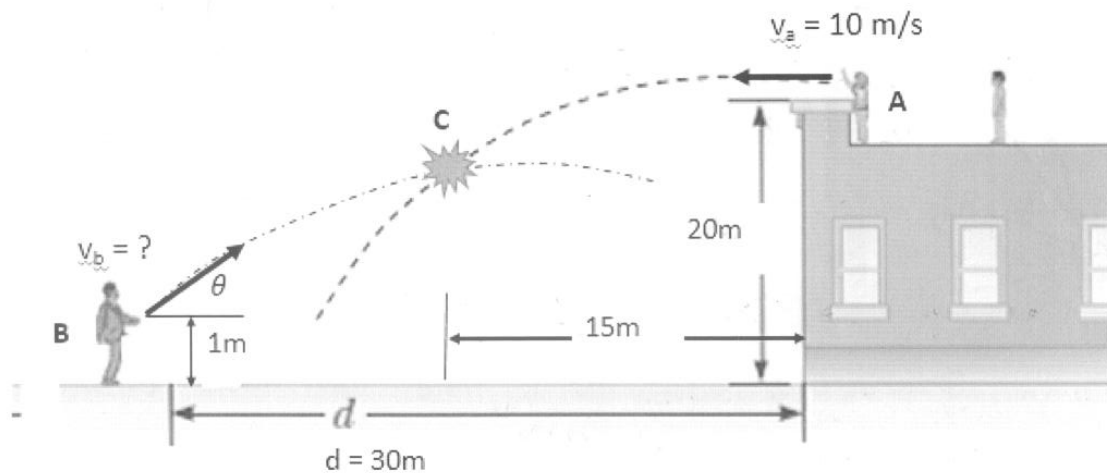

$$A) \quad X_a = X_{a0} + V_{0ax} t$$

$$15_m = 30_m - 10 \text{ m/s} t$$

$$(4 \text{ pts}) \quad t = 1.5 \text{ sec @ impact location}$$

$$Y = Y_{a0} + V_{0ay} t - \frac{g}{2} t^2$$

$V_{0ax} = \text{horizontal} \rightarrow 0$

$$Y_a = 20_m + 0 - \frac{9.81 \text{ m/s}^2}{2} (1.5 \text{ sec})^2$$

$$(4 \text{ pts}) \quad \boxed{Y_a = 8.96 \text{ m}} \quad \text{height @ impact point C}$$

EMA 202, Fall 2014

Name: _____

Midterm #1, closed book/notes, 90 min.

(Additional workspace for Question 2)

B. velocity of ball b.

$$\textcircled{2 \text{ pts}} \quad x_b = x_{b0} + v_{b0x} t_2$$

$$x_b = v_{b0} \cos \theta t_2$$

$$\textcircled{2 \text{ pts}} \quad t_2 = \frac{x_b}{v_{b0} \cos \theta} = \frac{15 \text{ m}}{v_{b0} \cos 35^\circ}$$

$$\textcircled{2 \text{ pts}} \quad y_b = y_{b0} + v_{b0y} t_2 - \frac{g}{2} t_2^2$$

$$8.96 \text{ m} = 1 \text{ m} + v_{b0} \sin \theta t_2 - \frac{9.81 \text{ m/s}^2}{2} t_2^2$$

$\textcircled{2 \text{ pts}}$ Sub in for t_2 & solve for v_{b0}

$$(8.96 \text{ m} - 1 \text{ m}) = v_{b0} \sin(35^\circ) \frac{15 \text{ m}}{v_{b0} \cos(35^\circ)} - \frac{9.81 \text{ m/s}^2}{2} \left(\frac{15}{v_{b0} \cos(35^\circ)} \right)^2$$

$$\textcircled{2 \text{ pts}} \quad \boxed{v_{b0} = 25.43 \text{ m/s}}$$

C. time delay

$$t_1 = t_2 + \Delta t$$

$$\textcircled{2 \text{ pts}} \quad \Delta t = t_1 - t_2$$

$$\textcircled{2 \text{ pts}} \quad t_2 = \frac{15 \text{ m}}{(25.43 \text{ m/s}) \cos 35^\circ} = .72 \text{ sec}$$

$$\textcircled{1 \text{ pt}} \quad \boxed{\Delta t = 1.5 - .72 = .78 \text{ sec}}$$

ball b is thrown
.78 sec after ball A.

EMA 202, Fall 2014
 Midterm #1, closed book/notes, 90 min.

Name: _____

Question 3 (25 points)

A 10kg mass, m , rotates around a vertical pole in a horizontal circular path with radius $R=1\text{m}$. The angles of the ropes with respect to the vertical direction are 35° and 55° .

Find the range of the velocity of the mass such that the mass will remain on the circular path described above?

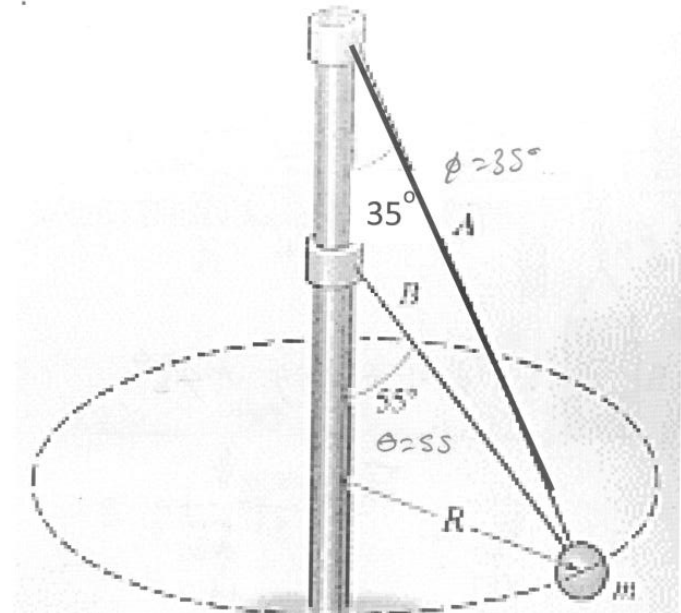

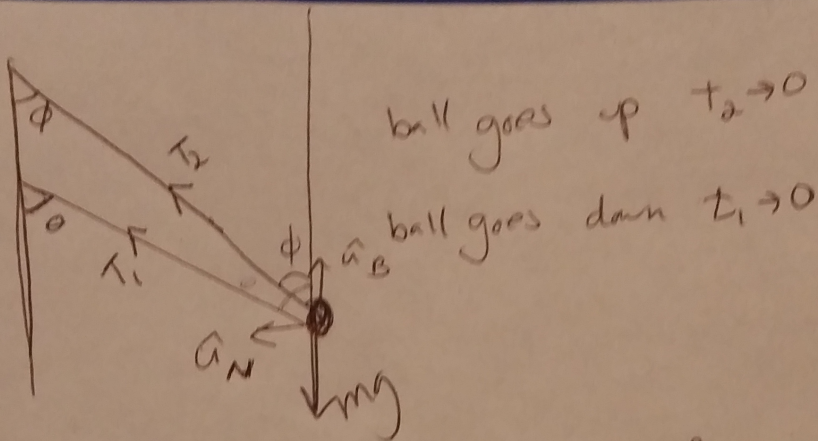

$$\leftarrow \sum \vec{F}_n = T_1 \sin \theta + T_2 \sin \phi = m a_n \frac{v^2}{R}$$

$$+\uparrow \sum \vec{F}_B = -mg + T_1 \cos \theta + T_2 \cos \phi = m a_b = 0$$

$a_b = 0$ for a circular path
- not moving up or down

For $T_2 \rightarrow 0$ ball moves up

$$F_n) \quad T_1 \sin \theta = m \frac{v^2}{R} \quad v^2 = \frac{T_1 R \sin \theta}{m}$$

$$F_B) \quad -mg + T_1 \cos \theta = 0 \quad T_1 = \frac{mg}{\cos \theta}$$

$$v^2 = \frac{mgR}{m} \tan \theta = 1 \text{ m} (9.81 \text{ m/s}^2) \tan 55$$

$$\boxed{v = 3.74 \text{ m/s}}$$

For $T_1 \rightarrow 0$ ball moves down

$$F_n) \quad T_2 \sin \phi = m \frac{v^2}{R}$$

$$v^2 = T_2 \sin \phi \cdot \frac{R}{m}$$

$$F_b) \quad -mg + T_2 \cos \phi = 0$$

$$T_2 = \frac{mg}{\cos \phi}$$

$$v^2 = \frac{mgR}{m} \tan \phi$$

$$v^2 = (9.81 \text{ m/s}^2)(1 \text{ m}) \tan 35^\circ$$

$$v = 2.62 \text{ m/s}$$

Velocity range for circular path

$$2.62 \text{ m/s} \leq v \leq 3.74 \text{ m/s}$$

EMA 202, Fall 2014
Midterm #1, closed book/notes, 90 min.

Name: _____

Question 4 (25 points)

Crates A and B of mass 50 kg and 75 kg, respectively, are released from rest. The linear elastic spring has stiffness $k=500\text{Nm}$.

Neglect the mass of the pulleys and cables and neglect friction in the pulley bearings.

If $\mu_k=0.25$ and the spring is initially unstretched, determine the speed of B after A slides 4 m.

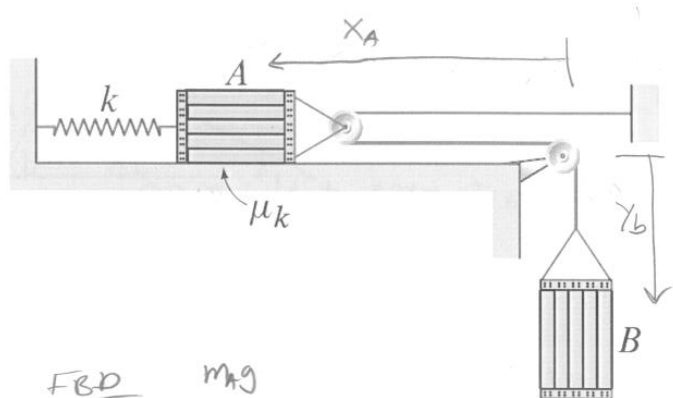

Energy method

$$T_1 + V_1 + U_{NC}^{ent} = T_2 + V_2$$

3 pts $T_1 = \frac{1}{2} m_A v_{A1}^2 + \frac{1}{2} m_B v_{B1}^2 = 0$, released from rest

3 pts $T_2 = \frac{1}{2} m_A v_{A2}^2 + \frac{1}{2} m_B v_{B2}^2$

3 pts $V_1 = V_{1s} + V_{1g} = \frac{1}{2} k \delta_1^2 + m_B g y_{B1}$, let $y_{B1} = 0$ & $\delta_1 = 0$
 $V_1 = 0$

3 pts $V_2 = \frac{1}{2} k \delta_2^2 - m_B g y_{B2}$, $\delta_2 = 4\text{m}$ $y_{B2} = ?$

Cable length to relate v_A & v_B

5 pts $L = 2x_A + y_B$

$$\dot{L} = 0 = 2v_A + v_B$$

$$\underline{v_B = -2v_A} \quad \therefore \quad \boxed{y_{B2} = 8\text{m}} \quad @ \quad x_{A2} = -4\text{m}$$

EMA 202, Fall 2014

Name: _____

Midterm #1, closed book/notes, 90 min.

(Additional workspace for Question 4)
external work from friction

3pts) $U_{nc}^{ext} = -F_f \cdot d$ w/ $F_f = \mu_k N$

$$+\uparrow \Sigma F_{yA} = -mg + N = m a_y \rightarrow 0$$

$$\underline{N = mg}$$

$$\underline{U_{nc}^{ext} = -\mu_k mg \delta_2} \quad \text{w/ } \delta_2 = 4m$$

Solve for V_{b2}

$$\cancel{0} T_1 + \cancel{0} V_1 + U_{nc}^{ext} = T_2 + V_2$$

$$-\mu_k m_A g \delta_2 = \frac{1}{2} m_a \left(\frac{V_{b2}}{2}\right)^2 + \frac{1}{2} m_b V_{b2}^2 + \frac{1}{2} k \delta_2^2 - m_b g y_{b2}$$

$$-\mu_k m_A g \delta_2 = \frac{1}{8} (m_a + 4m_b) V_{b2}^2 + \frac{1}{2} k \delta_2^2 - m_b g (8m)$$

$$V_{b2}^2 = \frac{m_b g (8m) - \mu_k m_A g \delta_2 - \frac{1}{2} k \delta_2^2}{\frac{1}{8} (m_a + 4m_b)}$$

$$V_{b2}^2 = \frac{75 \text{ kg} (9.81) 8m - 0.25 (50 \text{ kg}) (9.81 \text{ m/s}^2) (4m) - \frac{1}{2} (500 \text{ N/m}) (4m)^2}{\frac{1}{8} (50 \text{ kg} + 4 \cdot 75 \text{ kg})}$$

5pts) $V_{b2} = 5.65 \text{ m/s} \downarrow$

5.2 practice second midterm exams

5.2.1 Fall 2014

5.2.1.1 exam questions

EMA 202, Fall 2014

Name: _____

Midterm #2, closed book/notes, 90 min.

Instructions

- Write your name on every sheet.
- Show all of your work.
- To maximize opportunities for partial credit, solve problems symbolically to the extent possible and substitute numerical values at the end.
- Include free body diagrams for all equilibrium equations.
- This is a closed book examination.
- The only notes allowed are the equations provided with this exam.
- Calculators are allowed.
- The use of cell phones is prohibited.
- The instructors and the University of Wisconsin expect the highest standards of honesty and integrity in the academic performance of its students. It is important that the work submitted on this examination is yours and yours alone.
- Receiving or giving aid in an examination or using notes on a closed note exam will be considered cheating and will result in a grade of F and the case being reported to the Dean of Students Office.

Circle Your Discussion Section:

301	(Tu 1:20, David)
302	(Tu 2:25, David)
303	(W 3:30, David)
304	(Th 8:50, Matt)
305	(Th 12:05, Matt)
306	(Th 1:20, Matt)

Grading:

Q1	/25
Q2	/25
Q3	/25
Q4	/25
Total	/100

EMA 202, Fall 2014

Name: _____

Midterm #2, closed book/notes, 90 min.

Question 1 (25 points)

Conceptual questions: please include a few sentences or equations to justify your answers

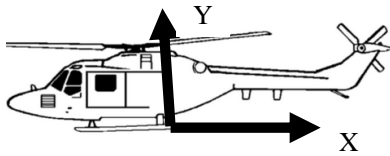
1A (7 points) A 1000kg helicopter starts from rest at $t = 0$ sec. Given the force components below, find the velocity vector of the helicopter after 10 seconds.

$$\sum F_x = 720t$$

$$\sum F_y = 2160 - 360t$$

$$\sum F_z = 0$$

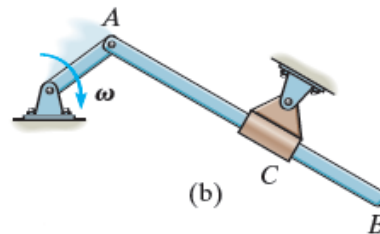
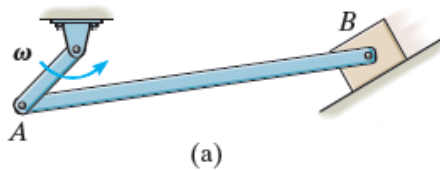
1B (6 points) Draw the instantaneous center of velocity of link AB for the two cases below

EMA 202, Fall 2014

Name: _____

Midterm #2, closed book/notes, 90 min.

1C (6 points) For a given instant, a rigid body has velocity at point A parallel to the velocity at point B. Does this guarantee that the angular velocity of body is zero at this instant?

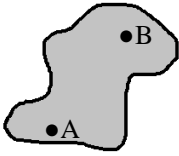

1D (6 points) At this instant, pulley A has an angular acceleration of 6 rad/s^2 . What is the acceleration of block B?

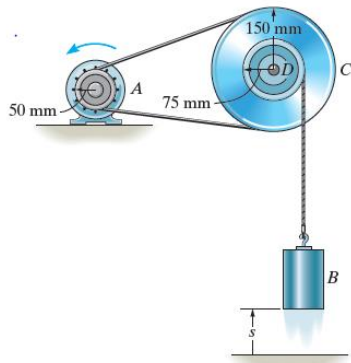

EMA 202, Fall 2014

Name: _____

Midterm #2, closed book/notes, 90 min.

Question 2 (25 points)

A 1 lb ball is dropped from rest and falls a distance of 4 ft before striking the smooth plane at A. If $e = 0.8$, determine the distance d to where the ball again strikes the plane at B.

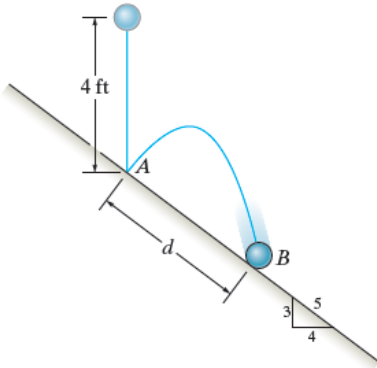

EMA 202, Fall 2014

Name: _____

Midterm #2, closed book/notes, 90 min.

Question 3 (25 points)

Three small spheres are welded to the light rigid frame which is rotating in a horizontal plane about point O with an angular velocity of 20 rad/s in the counter clockwise direction. If a moment $M_o = 30$ Nm in the clockwise direction is applied to the frame for 5 seconds,

- A) compute the angular impulse vector
- B) compute the new angular velocity after 5 seconds

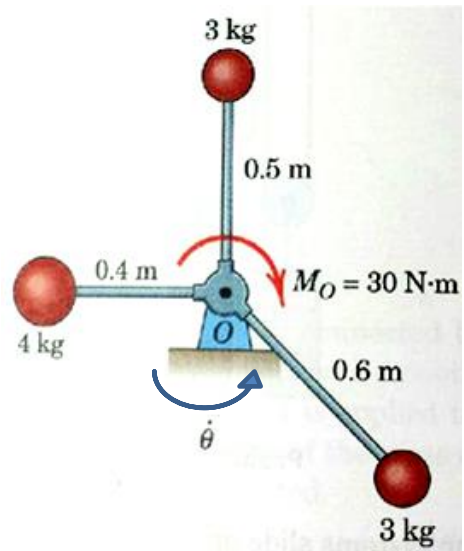

EMA 202, Fall 2014

Name: _____

Midterm #2, closed book/notes, 90 min.

Question 4 (25 points)

Bar AB rotates with a clockwise angular velocity of 10 rad/sec.

Find

- velocity vector for pt B
- velocity vector for pt C
- angular velocity of bar BC
- velocity vector of rack, v_R

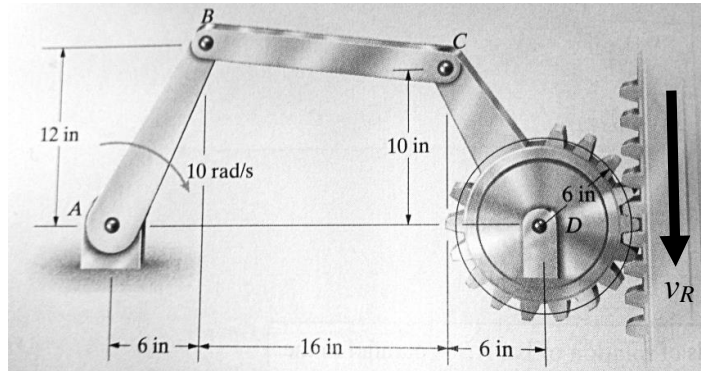

EMA 202, Fall 2014

Name: _____

Midterm #2, closed book/notes, 90 min.

Geometry:

$$\frac{A}{\sin a} = \frac{B}{\sin b} = \frac{C}{\sin c}$$

$$C^2 = A^2 + B^2 - 2AB \cos c$$

$$\cos^2 \theta + \sin^2 \theta = 1$$

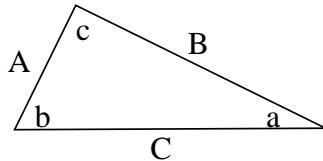

Particle Rectilinear Motion:

$$a = \frac{dv}{dt} \quad v = \frac{ds}{dt} \quad ads = vdv$$

For the special case of constant acceleration (a_c), and assuming initial conditions are specified at $t = 0$:

$$v(t) = v_o + a_c t \quad s(t) = s_o + v_o t + \frac{1}{2} a_c t^2 \quad v^2 = v_o^2 + 2a_c (s - s_o)$$

Particle Curvilinear Motion:

$$\text{Cartesian Results: } \vec{v} = \dot{x}\hat{i} + \dot{y}\hat{j} + \dot{z}\hat{k} \quad \vec{a} = \ddot{x}\hat{i} + \ddot{y}\hat{j} + \ddot{z}\hat{k}$$

Normal/Tangential Results:

$$\vec{v} = \dot{s}\hat{u}_t$$

$$\vec{a} = \dot{v}\hat{u}_t + \frac{v^2}{\rho}\hat{u}_n \quad \text{where } \rho = \frac{[1 + (dy/dx)^2]^{3/2}}{|d^2y/dx^2|}$$

Polar Results:

$$\vec{v} = \dot{r}\hat{u}_r + r\dot{\theta}\hat{u}_\theta$$

$$\vec{a} = (\ddot{r} - r\dot{\theta}^2)\hat{u}_r + (r\ddot{\theta} + 2\dot{r}\dot{\theta})\hat{u}_\theta$$

Spherical Results:

$$\vec{v} = \dot{r}\hat{u}_r + r\dot{\phi}\hat{u}_\phi + r\dot{\theta}\sin\phi\hat{u}_\theta$$

$$\vec{a} = (\ddot{r} - r\dot{\phi}^2 - r\dot{\theta}^2\sin^2\phi)\hat{u}_r + (r\ddot{\phi} + 2\dot{r}\dot{\phi} - r\dot{\theta}^2\sin\phi\cos\phi)\hat{u}_\phi + (r\ddot{\theta}\sin\phi + 2\dot{r}\dot{\theta}\sin\phi + 2r\dot{\phi}\dot{\theta}\cos\phi)\hat{u}_\theta$$

General Time Derivatives of a Vector:

$$\dot{\hat{u}}(t) = \vec{\omega}_u \times \hat{u}$$

$$\dot{\vec{A}}(t) = \dot{A}\hat{u}_A + \vec{\omega}_A \times \vec{A}$$

$$\ddot{\vec{A}}(t) = \ddot{A}\hat{u}_A + 2\vec{\omega}_A \times \dot{A}\hat{u}_A + \dot{\vec{\omega}}_A \times \vec{A} + \vec{\omega}_A \times (\vec{\omega}_A \times \vec{A})$$

Principle of Work and Energy: $\Sigma U_{1 \rightarrow 2} = T_2 - T_1$ where $U_{1 \rightarrow 2} = \int_1^2 \vec{F} \cdot d\vec{r}$ and $T = \frac{1}{2}mv^2$ Conservation of Energy (assumes only conservative forces): $T_1 + V_1 = T_2 + V_2$ (For rigid bodies, these results are unchanged except for the fact that $T = \frac{1}{2}mv_G^2 + \frac{1}{2}I_G\omega^2$)

EMA 202, Fall 2014

Name: _____

Midterm #2, closed book/notes, 90 min.

V is potential energy and takes different forms depending on the source. For terrestrial gravity, $V = mgy$, (mgy_G for a rigid body) while for a linear elastic spring, $V = \frac{1}{2}k\delta^2$

Power: $P = \vec{F} \cdot \vec{v}$ Efficiency: $\varepsilon = \frac{\text{power output}}{\text{power input}}$

Linear Impulse and Momentum: $\sum \bar{I}_{1 \rightarrow 2} = \bar{p}_2 - \bar{p}_1$ where $\bar{I}_{1 \rightarrow 2} = \int_1^2 \bar{F} dt$ and $\bar{p} = m\vec{v}$
(For rigid bodies, the linear impulse and momentum expressions are identical but with $\vec{v} = \vec{v}_G$)

Coefficient of restitution: $e = \frac{(v_B)_2 - (v_A)_2}{(v_A)_1 - (v_B)_1}$

Principle of Angular Impulse and Momentum: $\sum \bar{I}_{M1 \rightarrow 2} = \bar{H}_{O2} - \bar{H}_{O1}$ where
 $\bar{I}_{M1 \rightarrow 2} = \int_1^2 \bar{M}_O dt$ and $\bar{H} = \vec{r} \times m\vec{v}$

(For rigid bodies, this principle holds as long as O is either the center of gravity G or a point of fixed rotation. If the center of gravity, $H_G = I_G\omega$; if a fixed axis, $H_O = I_O\omega$.)

Relative General Plane Motion:

Translating Axes: $\vec{v}_B = \vec{v}_A + \vec{v}_{B/A} = \vec{v}_A + \vec{\omega} \times \vec{r}_{B/A}$
 $\vec{a}_B = \vec{a}_A + \vec{a}_{B/A} = \vec{a}_A + \vec{\alpha} \times \vec{r}_{B/A} - \omega^2 \vec{r}_{B/A}$

Rotating Axes: $\vec{v}_B = \vec{v}_A + (\vec{v}_{B/A})_{xy} + \vec{\Omega} \times \vec{r}_{B/A}$
 $\vec{a}_B = \vec{a}_A + (\vec{a}_{B/A})_{xy} + \dot{\vec{\Omega}} \times \vec{r}_{B/A} + \Omega \times (\Omega \times \vec{r}_{B/A}) + 2\Omega \times (\vec{v}_{B/A})_{xy}$

Equations of Motion: $\sum F_x = m(a_G)_x$; $\sum F_y = m(a_G)_y$
or $\sum F_t = m(a_G)_t$; $\sum F_n = m(a_G)_n$

$\sum M_G = I_G\alpha$ or $\sum M_O = I_O\alpha$ or ... if you must ...
 $\sum M_p = -\bar{y}m(a_G)_x + \bar{x}m(a_G)_y + I_G\alpha$

Mass Moment of Inertia: Definition, and in terms of radius of gyration, k : $I = \int r^2 dm = k^2m$ Parallel axis theorem: $I = I_G + md^2$

5.2.1.2 key solutions

EMA 202, Fall 2014

Midterm #2, closed book/notes, 90 min.

Name: _____

Question 1 (25 points)

Conceptual questions: please include a few sentences or equations to justify your answers

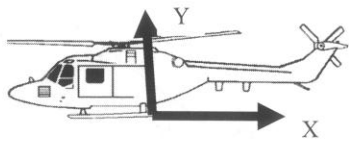
1A (7 points) A 1000kg helicopter starts from rest at $t = 0$ sec. Given the force components below, find the velocity vector of the helicopter after 10 seconds.

$$\begin{aligned}\sum F_x &= 720t \\ \sum F_y &= 2160 - 360t \\ \sum F_z &= 0\end{aligned}$$

$$m\vec{v}_1 + \int \Sigma \vec{F} dt = m\vec{v}_2 \quad w/ \quad \vec{v}_1 = 0$$

$$\int_0^{10} [F_x \hat{i} + F_y \hat{j} + F_z \hat{k}] dt = 1000 \text{ kg } \vec{v}_2$$

$$\int_0^{10} (720t \hat{i} + (2160 - 360t) \hat{j}) dt = 1000 \vec{v}_2$$

$$360t^2 \hat{i} + (2160t - 180t^2) \hat{j} \Big|_0^{10} = 1000 \vec{v}_2$$

$$\vec{v}_2 = 36 \hat{i} + 3.6 \hat{j} \text{ m/s}$$

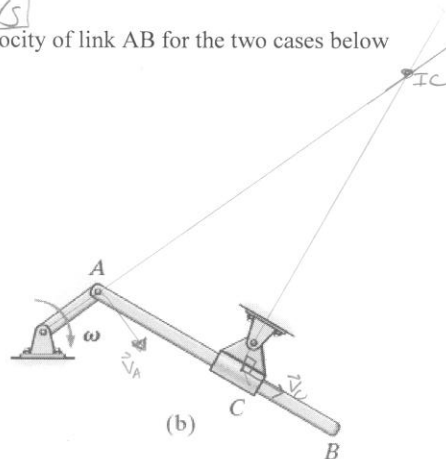
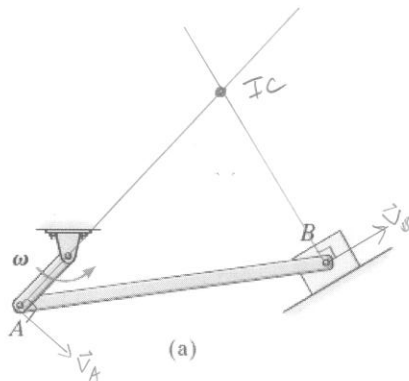
1B (6 points) Draw the instantaneous center of velocity of link AB for the two cases below

EMA 202, Fall 2014

Name: _____

Midterm #2, closed book/notes, 90 min.

1C (6 points) For a given instant, a rigid body has velocity at point A parallel to the velocity at point B. Does this guarantee that the angular velocity of body is zero?

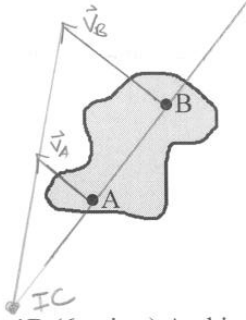

NO, \vec{v}_B & \vec{v}_A are parallel with coincident perpendicular lines.

$$\vec{v}_B = \vec{v}_{IC} + \vec{\omega} \times \vec{r}_{B/IC}$$

$$\text{or } \vec{v}_A = \vec{\omega} \times \vec{r}_{A/IC}$$

1D (6 points) At this instant, pulley A has an angular acceleration of 6 rad/s^2 . What is the acceleration of block B?

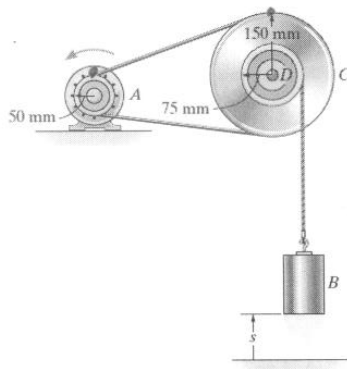

Kinematic compatibility

$$1) \alpha_A r_A = \alpha_C r_C$$

2) $\alpha_C = \alpha_D$ because they are on the same shaft

$$3) \alpha_D r_D = a_{By}$$

$$\text{From 1) } (6 \text{ rad/s}^2) 50 \text{ mm} = \alpha_C (150 \text{ mm})$$

$$\alpha_C = 2 \text{ rad/s}^2 = \alpha_D$$

$$\text{From 3) } (2 \text{ rad/s}^2) (75 \text{ mm}) = a_{By}$$

$$a_{By} = 150 \text{ mm/s}^2 \uparrow$$

EMA 202, Fall 2014

Name: _____

Midterm #2, closed book/notes, 90 min.

Question 2 (25 points)

A 1 lb ball is dropped from rest and falls a distance of 4ft before striking the smooth plane at A. If $e = 0.8$, determine the distance d to where the ball again strikes the plane at B.

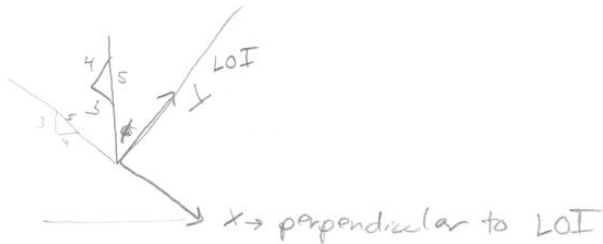
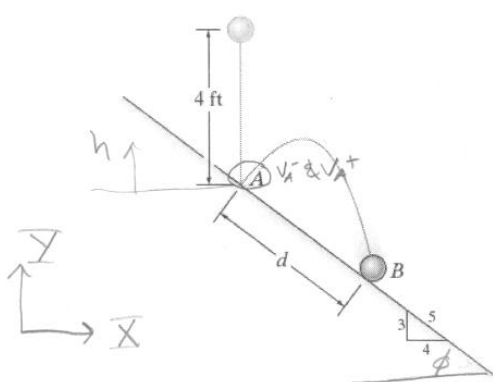

1) find velocity b/c impact

$$T_1 + V_1 = T_2 + V_2$$

$$mgh = \frac{1}{2} m (V_A^-)^2$$

$$32.2 \text{ ft/s}^2 (4 \text{ ft}) = \frac{1}{2} (V_A^-)^2$$

$$V_A^- = 16.05 \text{ ft/s}$$

In LOI direction

$$e = \frac{V_{Ay}^+ - V_p^+}{V_p^- - V_{Ay}^-}$$

let $V_p = \text{Velocity of plane} = 0$

$$0.8 = \frac{V_{Ay}^+}{-V_{Ay}^-}$$

$$V_{Ay}^+ = (0.8)(-V_{Ay}^-) = (0.8)\left(\frac{4}{5}\right)(16.04 \text{ ft/s})$$

$$V_{Ay}^+ = 10.27 \text{ ft/s}$$

$$\text{let } T_1 = 0 = \frac{1}{2} m v^2$$

$$V_2 = 0 \text{ base on datum}$$

EMA 202, Fall 2014

Name: _____

Midterm #2, closed book/notes, 90 min.

(Additional workspace for Question 2)

perpendicular to LOI

$$V_{Ax}^- = V_{Ax}^+ = \frac{3}{5}(16.05 \text{ ft/s})$$

$$\underline{V_{Ax}^+ = 9.63 \text{ ft/s}}$$

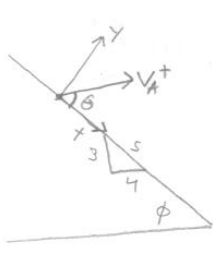

find angle

$$\tan \theta = \frac{V_{Ay}^+}{V_{Ax}^+} = \frac{10.27 \text{ ft/s}}{9.63 \text{ ft/s}} \quad \theta = 46.85^\circ$$

$$\phi = \tan^{-1}\left(\frac{3}{4}\right) = 36.87^\circ$$

Back to XY global coordinates

$$\text{let } \alpha = \theta - \phi = 46.85^\circ - 36.87^\circ = \underline{9.98^\circ}$$

$$\& \quad V_A^+ = \sqrt{V_{Ay}^{+2} + V_{Ax}^{+2}} = \sqrt{10.27^2 + 9.63^2} = \underline{14.08 \text{ ft/s}}$$

 X projectile motion

$$X_f = X_0 + V_{0x} t$$

$$X_f = 14.08 \cos(9.98) t$$

$$\& \quad X_f = d \left(\frac{4}{5}\right)$$

$$\frac{4}{5} d = 14.08 \cos(9.98) t$$

$$\Rightarrow \quad t = \frac{\frac{4}{5} d}{14.08 \cos 9.98} \quad \star \quad t = .0577d$$

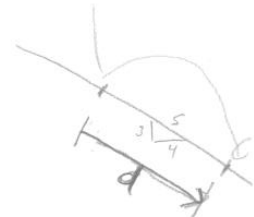

$$Y_f = Y_0 + V_{0y} t - \frac{32.2 \text{ ft/s}^2}{2} t^2$$

$$\& \quad Y_f = d \left(\frac{3}{5}\right)$$

$$-\frac{3}{5} d = 14.08 \sin(9.98) t - \frac{32.2}{2} t^2 \quad \star\star$$

Sub \star into $\star\star$ & solve for d

$$-\frac{3}{5} d = .141 d - .0536 d^2$$

$$\boxed{d = 13.8 \text{ ft}}$$

EMA 202, Fall 2014
Midterm #2, closed book/notes, 90 min.

Name: _____

Question 3 (25 points)

Three small spheres are welded to the light rigid frame which is rotating in a horizontal plane about point O with an angular velocity of 20 rad/s in the counter clockwise direction. If a moment $M_0 = 30$ Nm in the clockwise direction is applied to the frame for 5 seconds,

- A) compute the angular impulse
B) compute the new angular velocity after 5 seconds

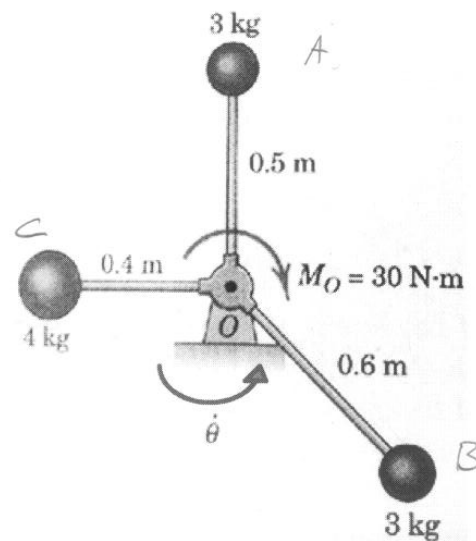

A) Impulse

$$\vec{I}_M = \int \vec{M} dt = \int_0^5 -30 \text{ Nm} dt \hat{k}$$

$$\boxed{\vec{I}_M = -30t \Big|_0^{5 \text{ sec}} \hat{k} = -150 \text{ Nm}\cdot\text{s} \hat{k}}$$

B) Impulse - momentum in \hat{k}

$$1) (h_{oA})_{z1} + (h_{oB})_{z1} + (h_{oC})_{z1} + I \hat{k} = (h_{oA})_{z2} + (h_{oB})_{z2} + (h_{oC})_{z2}$$

For any ball

$$(h_o)_z = \vec{r} \times m\vec{v} = \begin{pmatrix} \hat{u}_r & \hat{u}_\theta & \hat{u}_z \\ r & 0 & 0 \\ 0 & mv & 0 \end{pmatrix} = \begin{pmatrix} \hat{u}_r & \hat{u}_\theta & \hat{u}_z \\ r & 0 & 0 \\ 0 & mr\omega & 0 \end{pmatrix} \quad \begin{array}{l} \text{circular path} \\ v = r\omega \end{array}$$

$$2) (h_o)_z = mr^2\omega \hat{k}$$

use 2) in 1)

$$m_A r_A^2 \omega_0 + m_B r_B^2 \omega_0 + m_C r_C^2 \omega_0 + I_M = m_A r_A^2 \omega_f + m_B r_B^2 \omega_f + m_C r_C^2 \omega_f$$

$$\omega_0 [m_A r_A^2 + m_B r_B^2 + m_C r_C^2] + I_M = \omega_f (m_A r_A^2 + m_B r_B^2 + m_C r_C^2)$$

EMA 202, Fall 2014

Name: _____

Midterm #2, closed book/notes, 90 min.

(Additional workspace for Question 3)

$$[m_a r_a^2 + m_b r_b^2 + m_c r_c^2] = [3\text{kg} (0.5\text{m})^2 + 3\text{kg} (0.6\text{m})^2 + 4\text{kg} (0.4\text{m})^2]$$
$$= \underline{2.47} \text{ kg m}^2$$

$$\omega_o (2.47 \text{ kg m}^2) - 150 \text{ Nm s} = \omega_f (2.47 \text{ kg m}^2)$$

20 r/s

$$\omega_f = -40.73 \text{ r/s} \quad \text{clock wise rotation}$$

EMA 202, Fall 2014

Name: _____

Midterm #2, closed book/notes, 90 min.

Question 4 (25 points)

Bar AB rotates with a clockwise angular velocity of 10 rad/sec.

Find

- velocity vector for pt B
- velocity vector for pt C
- angular velocity of bar BC
- velocity of rack, v_r

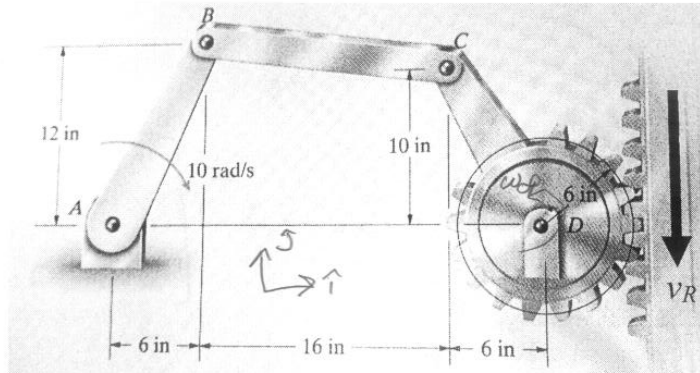
A) Find \vec{v}_B

$$\vec{v}_B = \vec{v}_A + \vec{\omega}_{AB} \times \vec{r}_{B/A}$$

$$\vec{v}_A = 0 \text{ pinned}$$

$$\vec{\omega}_{AB} = -10 \text{ rad/s } \hat{k}$$

$$\vec{r}_{B/A} = 6\hat{i} + 12\hat{j} \text{ (in)}$$

$$\vec{v}_B = 0 + \begin{bmatrix} i & j & k \\ 0 & 0 & -10 \\ 6 & 12 & 0 \end{bmatrix} = (-10)(6)\hat{j} - (-10)(12)\hat{i}$$

$$\vec{v}_B = 120\hat{i} - 60\hat{j} \text{ in/s} = 10\hat{i} - 5\hat{j} \text{ ft/s}$$

B & C) need \vec{v}_C & ω_{BC} , write 2 eqns for \vec{v}_C

$$\text{from left } \vec{v}_C = \vec{v}_B + \vec{\omega}_{BC} \times \vec{r}_{C/B} \text{ (next page)}$$

$$\text{from right } \vec{v}_C = \vec{v}_D + \vec{\omega}_{CD} \times \vec{r}_{C/D}$$

$\vec{v}_D = 0$ pinned

$$\vec{v}_C = \begin{bmatrix} i & j & k \\ 0 & 0 & \omega_{CD} \\ -6 \text{ in} & 10 \text{ in} & 0 \end{bmatrix} = -10\omega_{CD}\hat{i} - 6\omega_{CD}\hat{j} \text{ (in/s)}$$

EMA 202, Fall 2014

Name: _____

Midterm #2, closed book/notes, 90 min.

(Additional workspace for Question 4)

from 1) left side

$$\vec{V}_{CL} = \vec{V}_B + \vec{\omega}_{BC} \times \vec{r}_{C/B} \quad \text{w/} \quad \vec{r}_{C/B} = 16 \text{ in } \hat{i} - 2 \text{ in } \hat{j}$$

$$= \underbrace{120 \hat{i} - 60 \hat{j}}_{\vec{V}_B} (\text{in/s}) + \begin{bmatrix} i & j & k \\ 0 & 0 & \omega_{BC} \\ 16 & -2 & 0 \end{bmatrix}$$

$$\vec{V}_{CL} = 120 \hat{i} - 60 \hat{j} + \omega_{BC} 16 \hat{j} - (-2 \text{ in}) (\omega_{BC}) \hat{i}$$

$$3) \quad \vec{V}_{CL} = [120 + 2\omega_{BC}] \hat{i} + [-60 + 16\omega_{BC}] \hat{j} \quad (\text{in/s})$$

set $\vec{V}_{CL} = \vec{V}_{Ck}$

$$\begin{aligned} \hat{i}) \quad -10\omega_{CD} &= 120 + 2\omega_{BC} \\ \hat{j}) \quad -6\omega_{CD} &= 16\omega_{BC} - 60 \end{aligned} \quad \left. \begin{array}{l} \text{2 eqns \& 2 unknowns, solve for} \\ \omega_{CD} \& \omega_{BC} \end{array} \right\}$$

$$\ast \quad \omega_{CD} = -\frac{16}{6}\omega_{BC} + 10$$

sub \ast into \hat{i}

$$-10\left(-\frac{16}{6}\omega_{BC} + 10\right) = 120 + 2\omega_{BC}$$

$$\frac{160}{6}\omega_{BC} - 100 = 120 + 2\omega_{BC}$$

$$\textcircled{C} \quad \omega_{BC} = 8.92 \text{ r/s} \quad \text{rotates clock wise}$$

$$\omega_{CD} = -13.78 \text{ r/s} \quad \text{rotates counter clock wise}$$

 \ast sub ω_{BC} or ω_{CD} into \vec{V}_{CL} or \vec{V}_{CR} to get \vec{V}_C

$$\vec{V}_C = (120 + 2(8.92 \text{ r/s})) \hat{i} + (-60 + 16(8.92)) \hat{j} \Rightarrow \vec{V}_C = 137.84 \hat{i} + 68.9 \hat{j} \text{ in/s}$$

Q4 part D

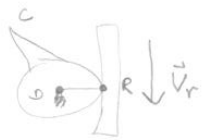
Find \vec{v}_R 

$$\vec{v}_R = \vec{v}_D + \vec{\omega}_{\omega} \times \vec{r}_{R/D} \quad \text{w/} \quad \vec{r}_{R/D} = 6 \text{ in } \hat{i}$$

$$\vec{v}_R = \begin{bmatrix} i & j & k \\ 0 & 0 & -13.78 \\ 6 & 0 & 0 \end{bmatrix} = (-13.78 \text{ r/s})(6 \text{ in}) \hat{j}$$

$$D) \quad \vec{v}_R = -82.68 \text{ in/s } \hat{j}$$

5.2.2 spring 2015 2014**5.2.2.1 exam questions****EMA 202, Spring 2015****Name:** _____**Midterm #2, closed book/notes, 90 min.****Instructions**

- Write your name on every sheet.
- Show all of your work.
- To maximize opportunities for partial credit, solve problems symbolically to the extent possible and substitute numerical values at the end.
- Include free body diagrams for all equilibrium equations.
- This is a closed book examination.
- The only notes allowed are the equations provided with this exam.
- Calculators are allowed.
- The use of cell phones is prohibited.
- The instructors and the University of Wisconsin expect the highest standards of honesty and integrity in the academic performance of its students. It is important that the work submitted on this examination is yours and yours alone.
- Receiving or giving aid in an examination or using notes on a closed note exam will be considered cheating and will result in a grade of F and the case being reported to the Dean of Students Office.

Circle Your Discussion Section:

301	(Tu 1:20, Harsha)
302	(Tu 2:25, Harsha)
303	(W 3:30, David)
304	(Th 8:50, David)
305	(Th 12:05, David)
306	(Th 1:20, David)

Grading:

Q1	/10
Q2	/30
Q3	/30
Q4	/30
Total	/100

EMA 202, Spring 2015

Name: _____

Midterm #2, closed book/notes, 90 min.

Question 1 (10 points)**1A (5 points)**

The expected damage from two types of perfectly plastic collisions are to be compared. In case 1, two identical cars traveling at the same speed impact each other head on. In case 2, the same car driving the same speed impacts a massive concrete wall. Would you expect the car to be more damaged in Case 1, Case 2, or equal damage in both cases? Use the impulse-momentum principle to justify your answer.



Case 1

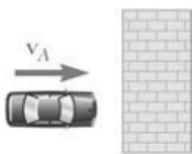

Case 2

1B (5 points)

Points A, B, and C are attached to the circular body shown below. Given the velocity at point A is 6 m/s in the vertical direction and the angular velocity of the circular body is clockwise at 2 rad/s. Locate the instantaneous center of velocity and draw the velocity vectors for points B and C in a clear and unambiguous fashion.

How does the magnitude of the velocity at point C compare to the magnitude of the velocity at point A?

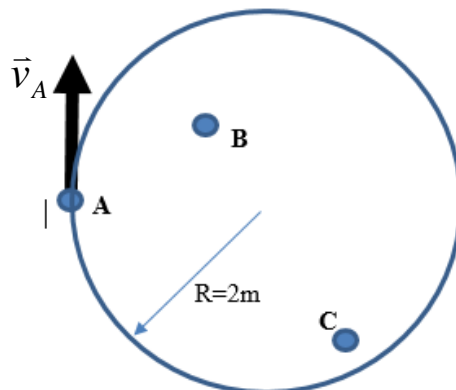

EMA 202, Spring 2015

Name: _____

Midterm #2, closed book/notes, 90 min.

Question 2 (30 points)

A boy located at point A throws a ball at the wall in a direction forming an angle of 45° with the line OA. Knowing that after hitting the wall the ball rebounds in a direction parallel to OA, determine the coefficient of restitution between the ball and the wall. (hint: the law of sines may be helpful to figure out the geometry)

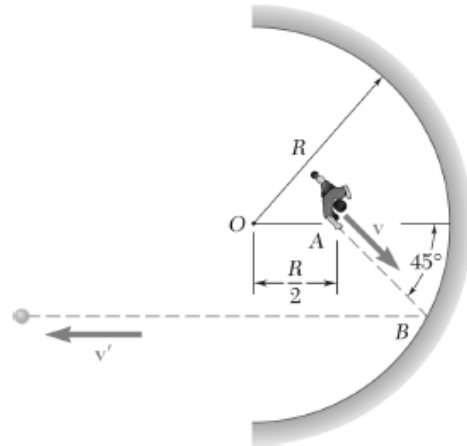

EMA 202, Spring 2015

Name: _____

Midterm #2, closed book/notes, 90 min.

Question 3 (30 points)

The 10-lb block is originally at rest on the smooth surface. It is acted upon by a radial force of 2 lbs and a horizontal force of 7 lbs that is always directed at 30° from the line tangent to the path as shown. If the cord fails at a tension of 30 lbs, determine the time required to break the cord. What is the speed of the block when this occurs? The block may be treated as a point mass.

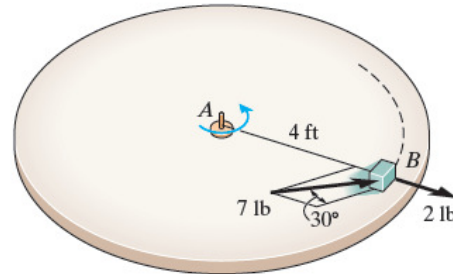

EMA 202, Spring 2015

Name: _____

Midterm #2, closed book/notes, 90 min.

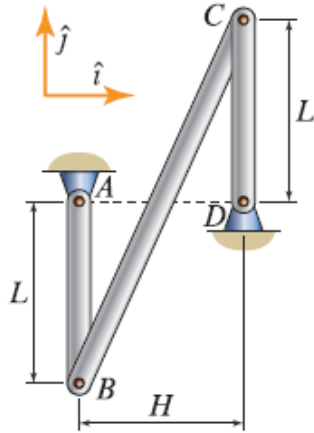
Question 4 (30 points)

At the instant shown, bars AB and CD are vertical. In addition, point C is moving to the left with an increasing speed of 4m/s. The magnitude of the acceleration at point C is 55m/s^2 . If $L = 0.5\text{m}$ and $H = 0.2\text{m}$, determine the angular accelerations of bars AB and BC.

EMA 202, Spring 2015

Name: _____

Midterm #2, closed book/notes, 90 min.

Geometry:

$$\frac{A}{\sin a} = \frac{B}{\sin b} = \frac{C}{\sin c}$$

$$C^2 = A^2 + B^2 - 2AB \cos c$$

$$\cos^2 \theta + \sin^2 \theta = 1$$

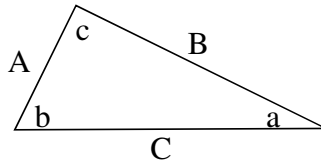

Particle Rectilinear Motion:

$$a = \frac{dv}{dt} \quad v = \frac{ds}{dt} \quad ads = vdv$$

For the special case of constant acceleration (a_c), and assuming initial conditions are specified at $t = 0$:

$$v(t) = v_o + a_c t \quad s(t) = s_o + v_o t + \frac{1}{2} a_c t^2 \quad v^2 = v_o^2 + 2a_c (s - s_o)$$

Particle Curvilinear Motion:

$$\text{Cartesian Results: } \vec{v} = \dot{x}\hat{i} + \dot{y}\hat{j} + \dot{z}\hat{k} \quad \vec{a} = \ddot{x}\hat{i} + \ddot{y}\hat{j} + \ddot{z}\hat{k}$$

Normal/Tangential Results:

$$\vec{v} = \dot{s}\hat{u}_t$$

$$\vec{a} = \dot{v}\hat{u}_t + \frac{v^2}{\rho}\hat{u}_n \quad \text{where } \rho = \frac{[1 + (dy/dx)^2]^{3/2}}{|d^2y/dx^2|}$$

Polar Results:

$$\vec{v} = \dot{r}\hat{u}_r + r\dot{\theta}\hat{u}_\theta$$

$$\vec{a} = (\ddot{r} - r\dot{\theta}^2)\hat{u}_r + (r\ddot{\theta} + 2\dot{r}\dot{\theta})\hat{u}_\theta$$

Spherical Results:

$$\vec{v} = \dot{r}\hat{u}_r + r\dot{\phi}\hat{u}_\phi + r\dot{\theta}\sin\phi\hat{u}_\theta$$

$$\vec{a} = (\ddot{r} - r\dot{\phi}^2 - r\dot{\theta}^2\sin^2\phi)\hat{u}_r + (r\ddot{\phi} + 2\dot{r}\dot{\phi} - r\dot{\theta}^2\sin\phi\cos\phi)\hat{u}_\phi$$

$$+ (r\ddot{\theta}\sin\phi + 2\dot{r}\dot{\theta}\sin\phi + 2r\dot{\phi}\dot{\theta}\cos\phi)\hat{u}_\theta$$

General Time Derivatives of a Vector:

$$\dot{\hat{u}}(t) = \vec{\omega}_u \times \hat{u}$$

$$\dot{\vec{A}}(t) = \dot{A}\hat{u}_A + \vec{\omega}_A \times \vec{A} \quad \ddot{\vec{A}}(t) = \ddot{A}\hat{u}_A + 2\vec{\omega}_A \times \dot{A}\hat{u}_A + \dot{\vec{\omega}}_A \times \vec{A} + \vec{\omega}_A \times (\vec{\omega}_A \times \vec{A})$$

Principle of Work and Energy: $\Sigma U_{1 \rightarrow 2} = T_2 - T_1$ where $U_{1 \rightarrow 2} = \int_1^2 \vec{F} \cdot d\vec{r}$ and $T = \frac{1}{2}mv^2$ Conservation of Energy (assumes only conservative forces): $T_1 + V_1 = T_2 + V_2$ (For rigid bodies, these results are unchanged except for the fact that $T = \frac{1}{2}mv_G^2 + \frac{1}{2}I_G\omega^2$)

EMA 202, Spring 2015

Name: _____

Midterm #2, closed book/notes, 90 min.

V is potential energy and takes different forms depending on the source. For terrestrial gravity, $V = mgy$, (mgy_G for a rigid body) while for a linear elastic spring, $V = \frac{1}{2}k\delta^2$

Power: $P = \vec{F} \cdot \vec{v}$ Efficiency: $\varepsilon = \frac{\text{power output}}{\text{power input}}$ Linear Impulse and Momentum: $\sum \vec{I}_{1 \rightarrow 2} = \vec{p}_2 - \vec{p}_1$ where $\vec{I}_{1 \rightarrow 2} = \int_1^2 \vec{F} dt$ and $\vec{p} = m\vec{v}$ (For rigid bodies, the linear impulse and momentum expressions are identical but with $\vec{v} = \vec{v}_G$)Coefficient of restitution: $e = \frac{(v_B)_2 - (v_A)_2}{(v_A)_1 - (v_B)_1}$ Principle of Angular Impulse and Momentum: $\sum \vec{I}_{M1 \rightarrow 2} = \vec{H}_{O2} - \vec{H}_{O1}$ where $\vec{I}_{M1 \rightarrow 2} = \int_1^2 \vec{M}_O dt$ and $\vec{H} = \vec{r} \times m\vec{v}$ (For rigid bodies, this principle holds as long as O is either the center of gravity G or a point of fixed rotation. If the center of gravity, $H_G = I_G \omega$, if a fixed axis, $H_O = I_O \omega$)

Relative General Plane Motion:

Translating Axes: $\vec{v}_B = \vec{v}_A + \vec{v}_{B/A} = \vec{v}_A + \vec{\omega} \times \vec{r}_{B/A}$
 $\vec{a}_B = \vec{a}_A + \vec{a}_{B/A} = \vec{a}_A + \vec{\alpha} \times \vec{r}_{B/A} - \omega^2 \vec{r}_{B/A}$ Rotating Axes: $\vec{v}_B = \vec{v}_A + (\vec{v}_{B/A})_{xy} + \vec{\Omega} \times \vec{r}_{B/A}$
 $\vec{a}_B = \vec{a}_A + (\vec{a}_{B/A})_{xy} + \dot{\vec{\Omega}} \times \vec{r}_{B/A} + \Omega \times (\Omega \times \vec{r}_{B/A}) + 2\Omega \times (\vec{v}_{B/A})_{xy}$ Equations of Motion: $\sum F_x = m(a_G)_x$; $\sum F_y = m(a_G)_y$
or $\sum F_t = m(a_G)_t$; $\sum F_n = m(a_G)_n$ $\sum M_G = I_G \alpha$ or $\sum M_O = I_O \alpha$ or ... if you must ...
 $\sum M_P = -\bar{y}m(a_G)_x + \bar{x}m(a_G)_y + I_G \alpha$ Mass Moment of Inertia: Definition, and in terms of radius of gyration, k : $I = \int r^2 dm = k^2 m$ Parallel axis theorem: $I = I_G + md^2$

5.2.2.2 key solutions

EMA 202, Spring 2015
Midterm #2, closed book/notes, 90 min.

Name: _____

Question 1 (10 points)

1A (5 points)

The expected damage from two types of perfectly plastic collisions are to be compared. In case 1, two identical cars traveling at the same speed impact each other head on. In case 2, the same car driving the same speed impacts a massive concrete wall. Would you expect the car to be more damaged in Case 1, Case 2, or equal damage in both cases? Use the impulse-momentum principle to justify your answer.

Look @ Impulse-momentum for left car in case 1 & case 2

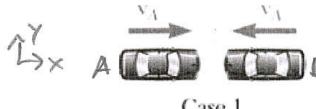

Case 1

car A) $m\vec{v}_{A1} + \vec{I}_A = m\vec{v}_{A2}$

$\vec{I}_A = -m\vec{v}_{A1}$

Case 2 cons. of momentum

$m\vec{v}_{A1} + m\vec{v}_{B1} = m\vec{v}_{A2} + m\vec{v}_{B2}$ w/ $\vec{v}_{A2} = \vec{v}_{B2}$ perfectly plastic

$\vec{v}_{A1} = v_A \hat{i}$
 $\vec{v}_{A2} = 0$ => show this for case 1

1) $m v_A - m v_A = 2 m v_{A2}$
 $0 = 2 m v_{A2}$ $v_{A2} = 0$

1B (5 points)

Points A, B, and C are attached to the circular body shown below. Given the velocity at point A is 6 m/s in the vertical direction and the angular velocity of the circular body is clockwise at 2 rad/s. Locate the instantaneous center of velocity and draw the velocity vectors for points B and C in a clear and unambiguous fashion.

How does the magnitude of the velocity at point C compare to the magnitude of the velocity at point A?

$\vec{v}_A = \vec{\omega} \times \vec{r}_{A/IC}$

$\vec{v}_A = 6 \text{ m/s } \hat{j}$

$\vec{\omega} = -2 \text{ rad/s } \hat{k}$

$\vec{r}_{A/IC} = r_x \hat{i} + r_y \hat{j}$

$6 \text{ m/s } \hat{j} = \begin{pmatrix} i & j & k \\ 0 & 0 & -2 \text{ rad/s} \\ r_x & r_y & 0 \end{pmatrix}$

$6 \text{ m/s } \hat{j} = -2 r_x \hat{j} + 2 r_y \hat{i} \Rightarrow r_y = 0 \ \& \ r_x = -3 \text{ m}$ $r_{A/IC} = -3 \text{ m } \hat{i} + 0 \hat{j}$

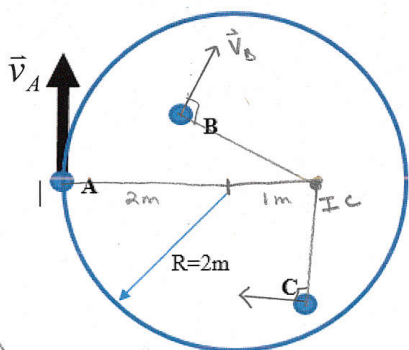

$|\vec{v}_C| < |\vec{v}_A|$, because point C is closer to the IC, ($|r_{C/IC}| < |r_{A/IC}|$) and they have the same $\vec{\omega}$.

EMA 202, Spring 2015

Name: _____

Midterm #2, closed book/notes, 90 min.

Question 2 (30 points)

A boy located at point A throws a ball at the wall in a direction forming an angle of 45° with the line OA. Knowing that after hitting the wall the ball rebounds in a direction parallel to OA, determine the coefficient of restitution between the ball and the wall. (hint: the law of sines may be helpful to figure out the geometry)

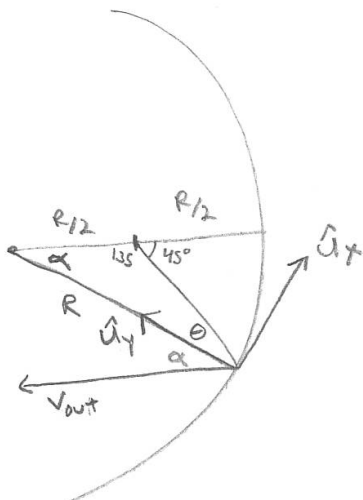
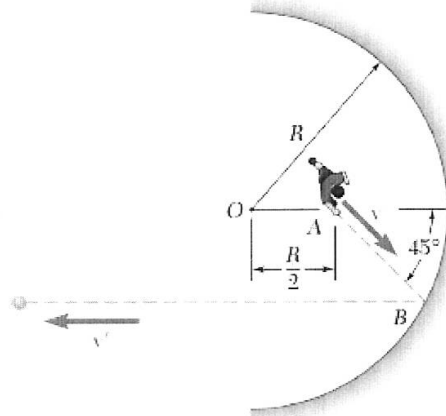

Law of sines

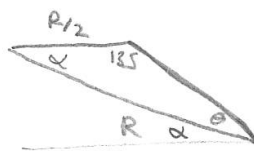

$$\frac{\sin \theta}{R/2} = \frac{\sin 135^\circ}{R}$$

$$\sin \theta = \frac{R}{2} \left(\frac{\sin 135^\circ}{R} \right)$$

$$\theta = 20.7^\circ$$

$$\alpha = 180 - 135 - \theta = 24.3^\circ = \alpha$$

Conservation of momentum in \hat{u}_x : $v_{in,x} = v_{out,x}$

$$-v_{in} \sin \theta = -v_{out} \sin \alpha$$

$$v_{out} = \frac{\sin \theta}{\sin \alpha} v_{in}$$

coefficient of restitution in \hat{u}_y (LOI)

$$e = \frac{v_{wall}^+ - v_{out,y}}{v_{in,y} - v_{wall}^-} = \frac{-v_{out} \cos \alpha}{-v_{in} \cos \theta} = \frac{\left(\frac{\sin \theta}{\sin \alpha} v_{in} \right) \cos \alpha}{v_{in} \cos \theta} = \frac{\tan \theta}{\tan \alpha}$$

$$e = \frac{\tan 20.7^\circ}{\tan 24.3^\circ} = .837$$

EMA 202, Spring 2015

Name: _____

Midterm #2, closed book/notes, 90 min.

Question 3 (30 points)

The 10-lb block is originally at rest on the smooth surface. It is acted upon by a radial force of 2 lbs and a horizontal force of 7 lbs that is always directed at 30° from the line tangent to the path as shown. If the cord fails at a tension of 30 lbs, determine the time required to break the cord. What is the speed of the block when this occurs? The block may be treated as a point mass.

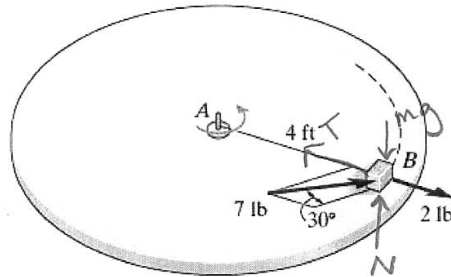

FBD top view

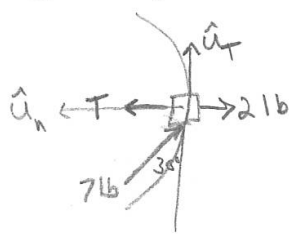
use ΣF_n to find velocity @ failure

$$\Sigma F_n = m a_n$$

$$T - 2 \text{ lbs} - 7 \text{ lb} \sin 30^\circ = m \frac{v^2}{r}$$

$$m = \frac{10 \text{ lbs}}{32.2 \text{ ft/s}^2}$$

$$r = 4 \text{ ft}$$

$$T_{\text{failure}} = 30 \text{ lbs}$$

$$v^2 = \frac{4 \text{ ft}}{\frac{10 \text{ lb}}{32.2 \text{ ft/s}^2}} (30 - 2 - 7 \sin 30^\circ) (\text{lbs})$$

$$v_{\text{fail}} = 17.76 \text{ ft/s}$$

Impulse-momentum in z-dir. ($\hat{u}_k = \hat{u}_t \times \hat{u}_n$)

$$(H_{A1})_z + \int_0^t M_{A2} dt = (H_{A2})_z$$

$$\vec{H}_{A1} = \vec{r} \times m \vec{v}_1 \rightarrow 0, \text{ @ rest} \rightarrow (H_{A1})_z = 0$$

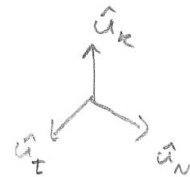

$$\vec{H}_{A2} = \vec{r} \times m \vec{v}_2, \quad \vec{r} = -4 \hat{u}_n \text{ ft}, \quad \vec{v}_2 = v_{\text{fail}} = 17.76 \text{ ft/s } \hat{u}_t$$

$$\vec{H}_{A2} = -4 \text{ ft } \hat{u}_n \times m (17.76) \hat{u}_t$$

$$\vec{H}_{A2} = (4 \text{ ft}) \left(\frac{10 \text{ lbs}}{32.2 \text{ ft/s}^2} \right) (17.76 \text{ ft/s}) \hat{u}_k = 22.06 \text{ ft-lb-s}$$

prob 3 continued

$$\vec{M}_A = \vec{r} \times \vec{F}$$

$$= \begin{pmatrix} \hat{u}_T & \hat{u}_N & \hat{u}_R \\ 0 & -4 & 0 \\ F_T & F_N & F_R \end{pmatrix}$$

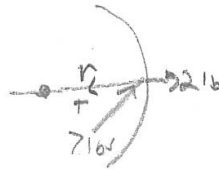

$$\vec{F} = 30 \hat{u}_N - 2 \hat{u}_N - 7 \sin 30 \hat{u}_N$$

$$+ 7 \cos 30 \hat{u}_T + (N - mg) \hat{u}_R$$

$$\vec{r} = -4 \text{ ft } \hat{u}_N$$

$$M_{A2} = 4 F_T = (4 \text{ ft})(7 \text{ lbs}) \cos 30^\circ$$

$$(H_{A1})_2 + \int_0^t M_{A2} dt = (H_{A2})_2$$

$$\int_0^t (4 \text{ ft})(7 \text{ lbs})(\cos 30^\circ) dt = 22.06 \text{ ft} \cdot \text{lb} \cdot \text{s}$$

$$(4 \text{ ft})(7 \text{ lbs}) \cos 30^\circ t \Big|_0^t = 22.06 \text{ ft} \cdot \text{lb} \cdot \text{s}$$

$$t = 0.91 \text{ sec}$$

EMA 202, Spring 2015

Name: _____

Midterm #2, closed book/notes, 90 min.

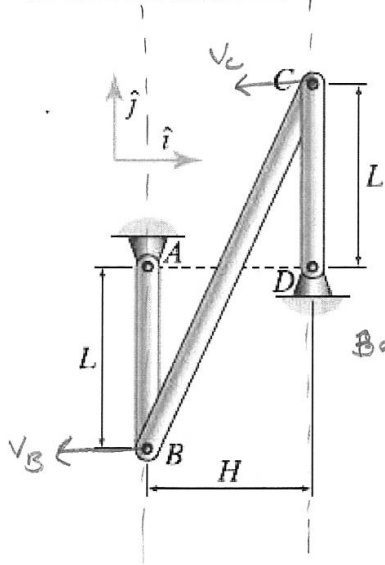
Question 4 (30 points)

At the instant shown, bars AB and CD are vertical. In addition, point C is moving to the left with an increasing speed of 4m/s. The magnitude of the acceleration at point C is 55m/s^2 . If $L = 0.5\text{m}$ and $H = 0.2\text{m}$, determine the angular accelerations of bars AB and BC.

Bar BC had IC @ $\infty \rightarrow \omega_{BC} = 0$

(Additional workspace for Question 4)

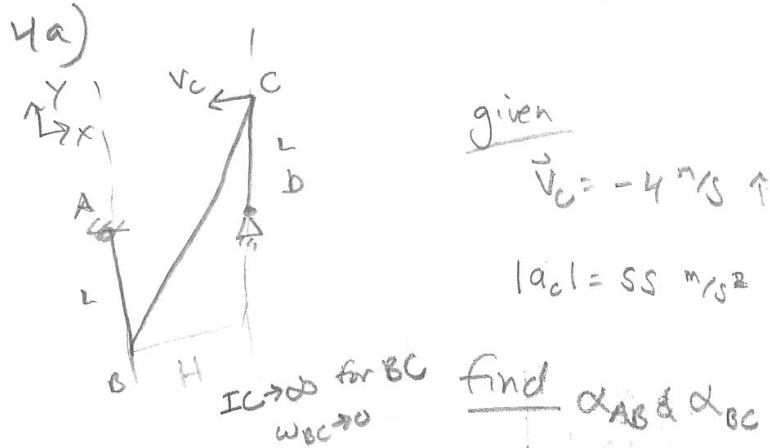

write eqns for acceleration @ pt. B

$$\textcircled{1} \vec{a}_B = \vec{a}_A + \alpha_{AB} \times \vec{r}_{B/A} - \omega_{AB}^2 \vec{r}_{B/A} \quad \text{w/ } \vec{r}_{B/A} = -L \hat{j}$$

$$\textcircled{2} \vec{a}_B = \vec{a}_C + \alpha_{BC} \times \vec{r}_{B/C} - \omega_{BC}^2 \vec{r}_{B/C}$$

from IC of bar BC

$$\omega_{BC} = 0$$

$$\vec{v}_B = \vec{v}_C + \vec{\omega}_{BC} \times \vec{r}_{B/C}$$

$$\vec{v}_B = \vec{\omega}_{AB} \times \vec{r}_{B/A} = \omega_{AB} \hat{k} \times -L \hat{j}$$

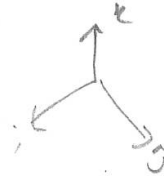

$$-4 \text{ m/s } \uparrow = \begin{bmatrix} i & j & k \\ 0 & 0 & \omega_{AB} \\ 0 & -L & 0 \end{bmatrix} = L \omega_{AB} \hat{i}$$

$$\omega_{AB} = \frac{-4 \text{ m/s}}{L} = \frac{-4 \text{ m/s}}{.5 \text{ m}} = -8 \text{ r/s}$$

$$\vec{\omega}_{AB} = -8 \text{ r/s } \hat{k}$$

4B
From ①

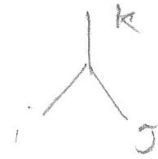

$$\vec{a}_B = \alpha_{AB} \hat{k} \times -L \hat{j} - (-8 \text{ m/s})^2 (-L \hat{j})$$

$$\textcircled{1} \quad \vec{a}_B = L \alpha_{AB} \hat{i} + 64L \hat{j} = (0.5 \text{ m}) \alpha_{AB} \hat{i} + 32 \text{ m/s}^2 \hat{j}$$

from ② $\vec{r}_{B/C} = -H \hat{i} - 2L \hat{j}$

$$\vec{a}_B = \underbrace{a_{cx} \hat{i} + a_{cy} \hat{j}}_{-44.7 \hat{i} - 32 \hat{j}} + \underbrace{\alpha_{BC} \hat{k} \times (-H \hat{i} - 2L \hat{j})}_{\substack{0 \text{ from IC} \\ -H \alpha_{BC} \hat{j} + 2L \alpha_{BC} \hat{i}}} - \omega_{BC}^2 (-H \hat{i} - 2L \hat{j})$$

given $|a_c| = 55 \text{ m/s}^2$

$$a_c^2 = a_{cx}^2 + a_{cy}^2$$

$$a_{cy} = -\frac{v_c^2}{L} = -\frac{(-4 \text{ m/s})^2}{0.5 \text{ m}} = -32 \text{ m/s}^2$$

$$a_{cx}^2 = (55 \text{ m/s}^2)^2 - (-32 \text{ m/s}^2)^2$$

$a_{cx} = \pm 44.7 \text{ m/s}^2 \rightarrow$ problem statement says $|v_c|$ increasing to the left.

$$\vec{a}_{cx} = -44.7 \hat{i} \text{ (m/s}^2\text{)}$$

set ① = ② for \vec{a}_B

$$i) \quad 0.5 \text{ m } \alpha_{AB} = -44.7 \text{ m/s}^2 + 2L \alpha_{BC}$$

$$\boxed{\vec{\alpha}_{AC} = -729.4 \text{ r/s}^2 \hat{k}}$$

$$j) \quad 32 \text{ m/s}^2 = -32 \text{ m/s} - H \alpha_{BC}$$

$$\alpha_{BC} = -320 \text{ r/s}^2$$

$$\boxed{\vec{\alpha}_{BC} = -320 \text{ r/s}^2 \hat{k}}$$

5.2.2.3 my solution to some of the problems of above exams

Problem 3, EMA 202 midterm exam, spring 2015

Midterm #2, EMA 202. Spring 2015. Nasser M. Abbasi ©
Nov 2012/2017

#3

using $\bar{h}_3 + \int_0^t M dt = \bar{h}_{final}$.
 but starting at rest, so $h_0 = 0$. and torque is
 $M = F_1 \cos \theta r$.
 $\int_0^t F_1 \cos \theta r dt = I \omega_{final}$ mass moment of inertia.
 $\Rightarrow F_1 \cos \theta r t_{final} = I \omega_{final} = mr^2 \omega_{final}$
 $t_{final} = \frac{mr^2 \omega_{final}}{F_1 \cos \theta r} = \boxed{\frac{mr \omega_{final}}{F_1 \cos \theta}} \quad (1)$

to find ω_{final} . FBD $F_1 \sin \theta \rightarrow T_{final} \leftarrow B \rightarrow 2rb \equiv \leftarrow r\omega^2$
 $\Rightarrow -F_1 \sin \theta + T_{final} - 2 = mr\omega_{final}^2$
 $\omega_{final}^2 = \frac{T_{final} - F_1 \sin \theta - 2}{mr} = \frac{30 - 7 \sin 30 - 2}{(\frac{10}{32.2})(4)} = 19.722$
 $\omega_{final} = 4.44 \text{ rad/sec}$
 Plus into (1) $\Rightarrow t_{final} = \frac{(\frac{10}{32.2})(4)(4.44)}{7 \cos 30} = \boxed{0.91 \text{ seconds}}$
 speed = $r\omega = \boxed{1.776 \text{ m/s}}$

Problem 4, EMA 202 midterm exam, spring 2015

Problem 4. midterm #2. EMA202, Spring 2015
 Nasser M. Abbasi
 Nov 20, 2017

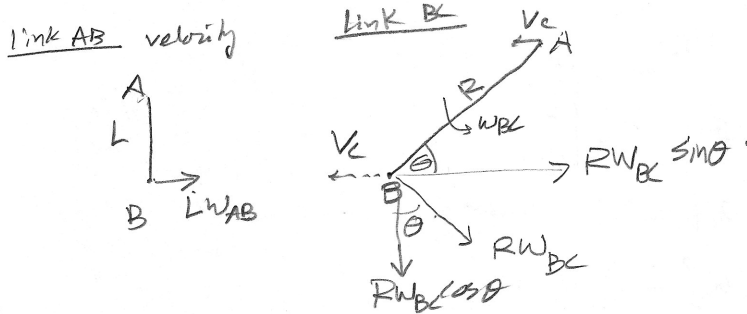
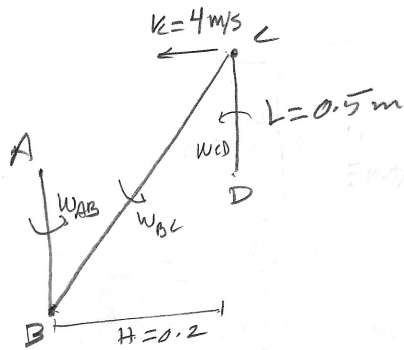

equating speed at B at both sides.

$$x: L W_{AB} = -v_C + R W_{BC} \sin \theta \quad \text{--- (1)}$$

$$y: 0 = -R W_{BC} \cos \theta \quad \text{--- (2)}$$

From (2) $\Rightarrow W_{BC} = 0$, From (1) $\Rightarrow L W_{AB} = -v_C$

but $v_C = 4 \text{ m/s} \Rightarrow W_{AB} = \frac{-v_C}{L} = \frac{-4}{0.5} = -8 \text{ rad/sec.}$

so $\boxed{W_{AB} = -8 \hat{k}}$ Clockwise rotation.

acceleration

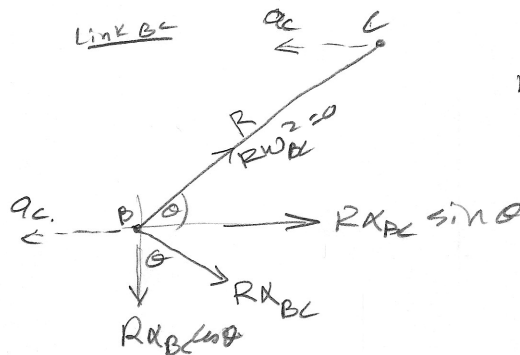
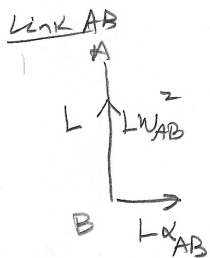

Now we need to find a_C .

looking at Link CD

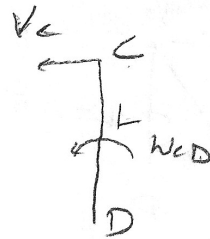

so $v_C = L\omega_{CD}$. We are given $v_C = 4 \text{ m/s}$. so

$$\omega_{CD} = \frac{v_C}{L} = \frac{4}{0.5} = 8 \text{ rad/sec. so } \boxed{\omega_{CD} = 8 \hat{k}}$$

acc

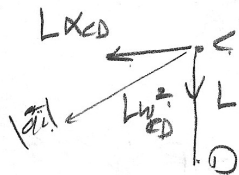

We are given that $|a_C| = 55$. Then,

$$\text{Then } |a_C|^2 = L^2 \alpha_{CD}^2 + (L\omega_{CD}^2)^2$$

$$55^2 = 0.5^2 \alpha_{CD}^2 + 0.5^2 (8^4)$$

$$\alpha_{CD}^2 = \frac{55^2 - 0.5^2 (8^4)}{0.5^2} = (89.465)^2$$

$$\boxed{\alpha_{CD} = 89.465 \text{ rad/s}^2}$$

$$L\alpha_{CD} = (0.5)(89.465) = 44.733 \text{ rad/s}^2$$

$$L\omega_{CD}^2 = (0.5)64 = 32$$

so at point C we have
now we go to last diagram.

5.2.3 Prep exam practice for second midterm

Name: _____

PrEPS Practice Exam 2
Fall 2017

1. At the given instant the wheel is rotating with the angular velocity and angular acceleration shown. Determine the velocity and acceleration of block B at this instant. The following given variables are provided due to lack of picture clarity.

$$\omega = 2 \text{ rad/s}$$

$$\alpha = 6 \text{ rad/s}^2$$

$$r = 0.3 \text{ m}$$

$$L = 0.5 \text{ m}$$

$$\Theta = 60^\circ$$

$$\Phi = 45^\circ$$

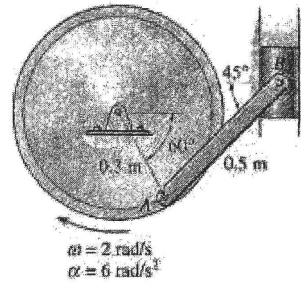

$$\vec{v}_B = \vec{v}_A + \vec{v}_{B/A} = \vec{v}_A + \vec{\omega}_{AB} \times \vec{r}_{B/A}$$

$$\vec{a}_B = \vec{a}_A + \vec{a}_{B/A} = \vec{a}_A + \vec{\alpha}_{AB} \times \vec{r}_{B/A} - \omega_{AB}^2 \vec{r}_{B/A}$$

Start by finding \vec{v}_A and \vec{a}_A

$$\vec{r}_A = r \cos \theta \hat{x} - r \sin \theta \hat{y}$$

$$\vec{v}_A = \vec{\omega}_0 \times \vec{r}_A = -\omega_0 \hat{k} \times (r \cos \theta \hat{x} - r \sin \theta \hat{y})$$

$$\vec{v}_A = -\omega_0 r \cos \theta \hat{y} - \omega_0 r \sin \theta \hat{x}$$

$$\begin{aligned} \vec{a}_A &= \vec{\alpha}_0 \times \vec{r}_A - \omega_0^2 \vec{r}_A = -\alpha_0 \hat{k} \times (r \cos \theta \hat{x} - r \sin \theta \hat{y}) - \omega_0^2 (r \cos \theta \hat{x} - r \sin \theta \hat{y}) \\ &= -\alpha_0 r \cos \theta \hat{y} - \alpha_0 r \sin \theta \hat{x} - \omega_0^2 r \cos \theta \hat{x} + \omega_0^2 r \sin \theta \hat{y} \end{aligned}$$

$$\vec{a}_A = (-\alpha_0 r \sin \theta - \omega_0^2 r \cos \theta) \hat{x} + (-\alpha_0 r \cos \theta + \omega_0^2 r \sin \theta) \hat{y}$$

now find \vec{v}_B and \vec{a}_B

$$\vec{r}_{B/A} = L \cos \phi \hat{x} + L \sin \phi \hat{y}$$

$$\begin{aligned} \vec{v}_B &= \vec{v}_A + \vec{\omega}_{AB} \times \vec{r}_{B/A} = -\omega_0 r \sin \theta \hat{x} - \omega_0 r \cos \theta \hat{y} + \omega_{AB} \hat{k} \times (L \cos \phi \hat{x} + L \sin \phi \hat{y}) \\ &= -\omega_0 r \sin \theta \hat{x} - \omega_0 r \cos \theta \hat{y} + \omega_{AB} L \cos \phi \hat{y} - \omega_{AB} L \sin \phi \hat{x} \end{aligned}$$

$$\vec{v}_B = (-\omega_0 r \sin \theta - \omega_{AB} L \sin \phi) \hat{x} + (-\omega_0 r \cos \theta + \omega_{AB} L \cos \phi) \hat{y}$$

$$v_{B,x} = 0 = -\omega_0 r \sin \theta - \omega_{AB} L \sin \phi$$

$$\omega_{AB} L \sin \phi = -\omega_0 r \sin \theta$$

$$\omega_{AB} = \frac{-\omega_0 r \sin \theta}{L \sin \phi}$$

$$\vec{v}_B = \left(-\omega_0 r \cos \theta - \frac{\omega_0 r \sin \theta}{L \sin \phi} L \cos \phi \right) \hat{y}$$

$$\vec{v}_B = (-\omega_0 r) \left(\cos \theta + \frac{\sin \theta}{\tan \phi} \right) \hat{y}$$

$$\vec{a}_B = \vec{a}_A + \vec{\alpha}_{AB} \times \vec{r}_{B/A} - \omega_{AB}^2 \vec{r}_{B/A}$$

$$\begin{aligned} \vec{a}_B &= -r(\alpha_0 \sin \theta + \omega_0^2 \cos \theta) \hat{x} + r(-\alpha_0 \cos \theta + \omega_0^2 \sin \theta) \hat{y} \\ &\quad + \alpha_{AB} \hat{z} \times (L \cos \phi \hat{x} + L \sin \phi \hat{y}) - \frac{\omega_0^2 r^2 \sin^2 \theta}{L^2 \sin^2 \phi} (L \cos \phi \hat{x} + L \sin \phi \hat{y}) \\ &= -r(\alpha_0 \sin \theta + \omega_0^2 \cos \theta) \hat{x} + r(-\alpha_0 \cos \theta + \omega_0^2 \sin \theta) \hat{y} \\ &\quad + \alpha_{AB} L \cos \phi \hat{y} - \alpha_{AB} L \sin \phi \hat{x} - \frac{\omega_0^2 r^2 \sin^2 \theta L \cos \phi}{L^2 \sin^2 \phi} \hat{x} - \frac{\omega_0^2 r^2 \sin^2 \theta L \sin \phi}{L^2 \sin^2 \phi} \hat{y} \end{aligned}$$

$$\begin{aligned} \vec{a}_B &= \left(-r \alpha_0 \sin \theta - r \omega_0^2 \cos \theta - \alpha_{AB} L \sin \phi - \frac{\omega_0^2 r^2 \sin^2 \theta \cos \phi}{L \sin^2 \phi} \right) \hat{x} \\ &\quad + \left(-r \alpha_0 \cos \theta + r \omega_0^2 \sin \theta + \alpha_{AB} L \cos \phi - \frac{\omega_0^2 r^2 \sin^2 \theta}{L \sin \phi} \right) \hat{y} \end{aligned}$$

$$a_{B,x} = 0 = r \alpha_0 \sin \theta + r \omega_0^2 \cos \theta + \alpha_{AB} L \sin \phi + \frac{\omega_0^2 r^2 \sin^2 \theta \cos \phi}{L \sin^2 \phi}$$

$$\alpha_{AB} L \sin \phi = - \left(r \alpha_0 \sin \theta + r \omega_0^2 \cos \theta + \frac{\omega_0^2 r^2 \sin^2 \theta \cos \phi}{L \sin^2 \phi} \right)$$

$$\alpha_{AB} = - \left(\frac{r \alpha_0 \sin \theta + r \omega_0^2 \cos \theta}{L \sin \phi} + \frac{\omega_0^2 r^2 \sin^2 \theta \cos \phi}{L^2 \sin^3 \phi} \right)$$

$$\vec{a}_B = \left(-r \alpha_0 \cos \theta + r \omega_0^2 \sin \theta - \frac{r \alpha_0 \sin \theta \cos \phi + r \omega_0^2 \cos \theta \cos \phi}{\sin \phi} + \frac{\omega_0^2 r^2 \sin^2 \theta \cos^2 \phi}{L \sin^3 \phi} - \frac{\omega_0^2 r^2 \sin^2 \theta}{L \sin \phi} \right) \hat{y}$$

$$\vec{v}_B = -0.8196 \text{ m/s}$$

$$\vec{a}_B = -2.0196 \text{ m/s}^2$$

Name: _____

PrEPS Practice Exam 2
Fall 2017

2. The ball of mass m_A is thrown at the suspended block of mass m_B with velocity v_A . If the coefficient of restitution between the ball and the block is e .

- Determine the velocity of the ball and block after the impact.
- Determine the maximum height h to which the block will swing before it momentarily stops.
- If the time of impact between the ball and the block is Δt , determine the average normal force exerted on the block.

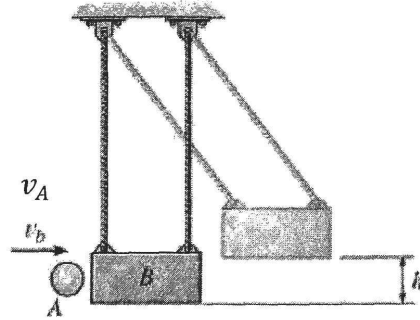

Knowns:

$$m_A = 2\text{kg}, m_B = 20\text{kg}, v_A = 4\frac{\text{m}}{\text{s}}, g = 9.81\frac{\text{m}}{\text{s}^2}, e = 0.8, \Delta t = 0.005\text{s}$$

Name: _____

PrEPS Practice Exam 2
Fall 2017

2. The ball of mass m_A is thrown at the suspended block of mass m_B with velocity v_A . If the coefficient of restitution between the ball and the block is e .

- Determine the velocity of the ball and block after the impact.
- Determine the maximum height h to which the block will swing before it momentarily stops.
- If the time of impact between the ball and the block is Δt , determine the average normal force exerted on the block.

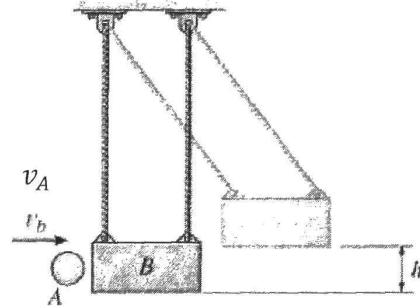

Knowns:

$$m_A = 2\text{kg}, m_B = 20\text{kg}, v_A = 4 \frac{\text{m}}{\text{s}}, g = 9.81 \frac{\text{m}}{\text{s}^2}, e = 0.8, \Delta t = 0.005\text{s}$$

Conservation of Momentum

$$m_A v_A^- + m_B v_B^- = m_A v_A^+ + m_B v_B^+$$

Coefficient of Restitution

$$e = \frac{v_A^+ - v_B^+}{v_B^- - v_A^-}$$

a)

$$e = \frac{v_A^+ - v_B^+}{-v_A^-} \quad * v_B^- = 0$$

$$-e \cdot v_A^- = v_A^+ - v_B^+$$

$$v_B^+ - e v_A^- = v_A^+$$

$$m_A v_A^- = m_A (v_B^+ - e v_A^-) + m_B v_B^+$$

$$m_A v_A^- = m_A v_B^+ - m_A e v_A^- + m_B v_B^+$$

$$m_A v_A^- + m_A e v_A^- = v_B^+ (m_A + m_B)$$

$$v_B^+ = \frac{m_A v_A^- + m_A e v_A^-}{(m_A + m_B)} \Rightarrow v_B^+ = 0.655 \frac{\text{m}}{\text{s}}$$

$$(0.655) - e v_A^- = v_A^+$$

$$v_B^+ = 0.655 \frac{\text{m}}{\text{s}} \quad v_A^+ = -2.55 \frac{\text{m}}{\text{s}}$$

$$b) \quad T_1 + V_1 = T_2 + V_2$$

$$T_1 = \frac{1}{2} m_B V_B^+{}^2$$

$$V_1 = mg(0) = 0$$

$$T_2 = \frac{1}{2} m_B (0)^2 = 0$$

$$V_2 = mgh$$

$$\frac{1}{2} m_B (V_B^+)^2 = mgh$$

$$\frac{V_B^+{}^2}{2g} = h$$

$$\boxed{h = 0.02184 \text{ m}}$$

$$c) \quad \sum m \vec{v}_1 + \sum \int_{t_1}^{t_2} \vec{F} dt = \sum m \vec{v}_2$$

$$\cancel{m_B V_B^-} + \int_0^{\Delta t} F_{\text{AVG}} dt = m_B V_B^+$$

$$F_{\text{AVG}} \cdot \Delta t = m_B V_B^+$$

$$F_{\text{AVG}} = \frac{m_B V_B^+}{\Delta t}$$

$$\boxed{F_{\text{AVG}} = 2618.18 \text{ N}}$$

Name: _____

PrEPS Practice Exam 2
Fall 2017

3. The Earth follows an elliptical path around the Sun as shown. Given the velocity of the Earth at it's current position is $30 \frac{km}{s} \hat{u}_T$, find the maximum and minimum velocity of Earth as it travels around the Sun. The angular momentum of the Earth about the Sun is conserved. Note: $a = 160 Gm$, $b = 140 Gm$, and the equations for an ellipse have been included for your veiving pleasure.

$$\frac{x^2}{a^2} + \frac{y^2}{b^2} = 1$$

$$a^2 - b^2 = c^2$$

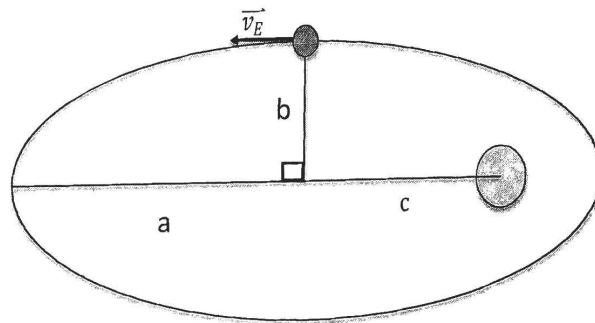

Name: _____

PrEPS Practice Exam 2
Fall 2017

3. The Earth follows an elliptical path around the Sun as shown. Given the velocity of the Earth at it's current position is $30 \frac{\text{km}}{\text{s}} \hat{u}_T$, find the maximum and minimum velocity of Earth as it travels around the Sun. The angular momentum of the Earth about the Sun is conserved. Note: $a = 160 \text{ Gm}$, $b = 140 \text{ Gm}$, and the equations for an ellipse have been included for your viewing pleasure.

$$\frac{x^2}{a^2} + \frac{y^2}{b^2} = 1$$

$$a^2 - b^2 = c^2$$

$$c = 77.45 \text{ Gm}$$

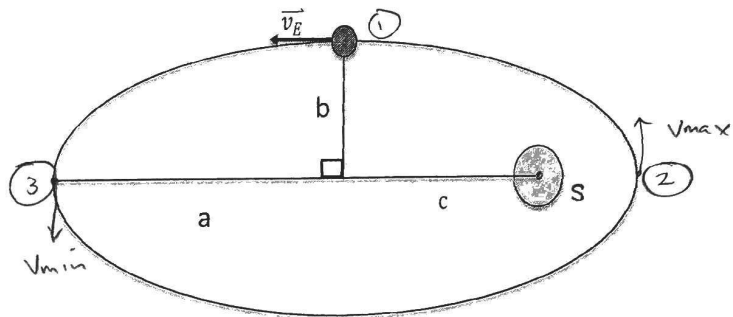

Angular Momentum about Sun is conserved at any point on the ellipse

$$\vec{h}_s = \vec{r} \times m\vec{v}$$

$$\textcircled{1} \vec{h}_s = b \hat{j} \times -m v_E \hat{i}$$

$$\vec{h}_s = b m v_E \hat{k}$$

proportional
If $h \propto r m v$ and h is const, then
max v would occur at shortest r .

$$\textcircled{2} \vec{h}_s = (a-c) \hat{i} \times m v_{\max} \hat{j}$$

$$\vec{h}_s = (a-c) m v_{\max} \hat{k}$$

$$\textcircled{1} = \textcircled{2}$$

$$b m v_E = (a-c) m v_{\max}$$

$$v_{\max} = \frac{b v_E}{(a-c)} = \frac{(140 \times 10^9 \text{ m})(30 \times 10^3 \text{ m/s})}{(160 - 77.45) \times 10^9 \text{ m}}$$

$$v_{\max} = 50.88 \text{ km/s}$$

Name: _____

PrEPS Practice Exam 2
Fall 2017

$$\textcircled{3} \vec{h}_s = -(a+c)\hat{i} \times -mV_{\min}\hat{j}$$

$$\vec{h}_s = (a+c)mV_{\min}$$

$$\textcircled{1} = \textcircled{3}$$

$$b\gamma V_E = (a+c)mV_{\min}$$

$$V_{\min} = \frac{bV_E}{(a+c)} = \frac{(140 \times 10^9)(30 \text{ km/s})}{(160 + 77.45)}$$

$$V_{\min} = 17.69 \text{ km/s}$$

5.3 practice exam for finals

5.3.1 final spring 2015

EMA 202, Spring 2015
Final, closed book/notes, 120 min.

Name: _____

Question 1 (25 points)

The assembly shown consists of a 10-kg rod AB and a 20-kg circular disc C. If it is subject to a torque of $M = (20t^{3/2})$ Nm, where t is in seconds, determine its angular velocity when $t = 3$ sec. When $t = 0$ the assembly is rotating clockwise at 6 rad/s.

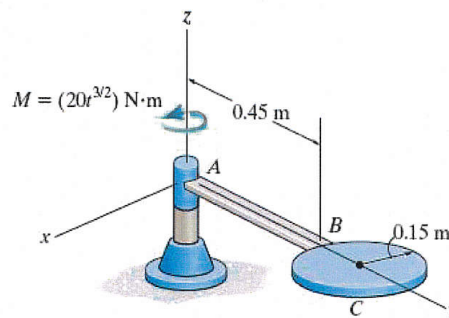

Angular momentum Impulse

$$\hat{k}) \quad I_A \omega_1 + \int_0^3 M_z dt = I_A \omega_2$$

$$I_A = I_{rod_A} + I_{disc_A} = \frac{1}{3} m_{rod} L_{rod}^2 + \frac{1}{2} m_{disc} r_{disc}^2 + m_{disc} (L_{rod} + r_{disc})^2$$

$$I_A = \frac{1}{3} (10 \text{ kg}) (.45 \text{ m})^2 + \frac{1}{2} (20 \text{ kg}) (.15 \text{ m})^2 + 20 \text{ kg} (.45 + .15 \text{ m})^2$$

$$I_A = 8.1 \text{ kg-m}^2$$

$$\omega_1 = -6 \text{ r/s}$$

$$M_z = 20 t^{3/2} \text{ Nm}$$

$$(8.1 \text{ kg-m}^2)(-6 \text{ r/s}) + \int_0^3 20 t^{3/2} dt = (8.1 \text{ kg-m}^2) \omega_2$$

$$-48.6 \text{ Nm-s} + \frac{20 t^{5/2}}{5/2} \Big|_0^3 = (8.1 \text{ kg-m}^2) \omega_2$$

$$\omega_2 = 9.4 \text{ r/s} \quad \text{counter clockwise}$$

$$\vec{\omega}_2 = 9.4 \text{ r/s} \hat{k}$$

EMA 202, Spring 2015
Final, closed book/notes, 120 min.

Name: _____

Question 2 (25 points)

The disc A is pinned at O and weighs 15lbs. A 1-ft rod weighing 2lbs and a 1-ft diameter sphere weighing 10lbs are welded to the disc, as shown. If the spring is originally stretched 1ft and the sphere is released from the position shown, determine the angular velocity of the disc when it has rotated 90°. Assume that the spring wraps around the disc.

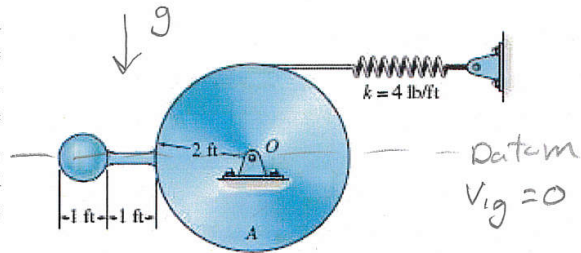

$$\begin{aligned}
 & \sum M_O = 10 \text{ lb}(3.5 \text{ ft}) + 2 \text{ lb}(2.5 \text{ ft}) - 4 \text{ lb}(2 \text{ ft}) = I_O \alpha \\
 & 32 \text{ ft}\cdot\text{lb} = I_O \alpha \\
 & \alpha \text{ is in } +k\text{-direction}
 \end{aligned}$$

Work-energy eqn

$$T_1 + V_1 + U_{12} = T_2 + V_2$$

$T_1 = 0$ system released from rest

$$V_1 = \frac{1}{2} k s_1^2 = \frac{1}{2} (4 \text{ lb/ft})(1 \text{ ft})^2 = 2 \text{ ft}\cdot\text{lb}$$

$U_{12} = 0$ no external N.C. work

$$T_2 = T_{disc_2} + T_{rod_2} + T_{sphere_2}$$

$$T_{disc_2} = \frac{1}{2} I_{disc_O} \omega_2^2 = \frac{1}{2} \left(\frac{1}{2} m_{disc} r^2 \right) \omega_2^2 = \frac{1}{2} \left(\frac{1}{2} \left(\frac{15 \text{ lb}}{32.2 \text{ ft/s}^2} \right) (2 \text{ ft})^2 \right) \omega_2^2$$

$$T_{disc_2} = .466 \omega_2^2$$

$$T_{rod_2} = \frac{1}{2} I_{rod_O} \omega_2^2 = \frac{1}{2} \left(\frac{1}{12} m_{rod} L^2 + m_{rod} \left(\frac{L}{2} + r \right)^2 \right) \omega_2^2$$

$$T_{rod_2} = \frac{1}{2} \left[\frac{1}{12} \left(\frac{2 \text{ lbs}}{32.2 \text{ ft/s}^2} \right) (1 \text{ ft})^2 + \left(\frac{2 \text{ lbs}}{32.2 \text{ ft/s}^2} \right) \left(\frac{1 \text{ ft}}{2} + 2 \text{ ft} \right)^2 \right] \omega_2^2 = .197 \omega_2^2$$

EMA 202, Spring 2015

Name: _____

Final, closed book/notes, 120 min.

(Additional workspace for Question 2)

$$T_{\text{sphere}_2} = \frac{1}{2} I_{\text{sphere}_0} \omega_2^2 = \frac{1}{2} \left(\frac{2}{5} m_s r_s^2 + m_s (r_{\text{disc}} + L_{\text{rod}} + r_s)^2 \right) \omega_2^2$$

$$T_{\text{sphere}_2} = \frac{1}{2} \left(\frac{2}{5} \left(\frac{10 \text{ lb}}{32.2 \text{ ft/s}^2} \right) \left(\frac{1}{2} \text{ ft} \right)^2 + \left(\frac{10 \text{ lb}}{32.2 \text{ ft/s}^2} \right) \left(2 \text{ ft} + 1 \text{ ft} + \frac{1}{2} \text{ ft} \right)^2 \right) \omega_2^2$$

$$T_{\text{sphere}_2} = 1.918 \omega_2^2$$

$$T_2 = (.466 + .197 + 1.918) \omega_2^2$$

$$T_2 = 2.58 (1 \text{ b-ft-s}^2) \omega_2^2$$

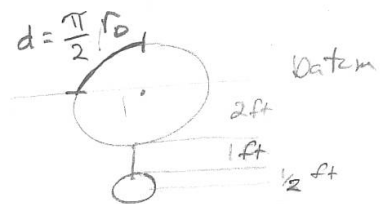

$$V_2 = V_{2g, \text{sphere}} + V_{2g, \text{rod}} + V_{2\text{spring}}$$

$$V_{2g, \text{sphere}} = m_s g h_s = 10 \text{ lbs} (-3.5 \text{ ft}) = \underline{-35 \text{ ft-lb}}$$

$$V_{2g, \text{rod}} = m_r g h_r = 2 \text{ lb} (-2.5 \text{ ft}) = \underline{-5 \text{ ft-lb}}$$

$$V_{2\text{spring}} = \frac{1}{2} k \delta_2^2 = \frac{1}{2} k \left(\frac{\pi}{2} r_0 + 1 \text{ ft} \right)^2$$

$$V_{2\text{spring}} = \frac{1}{2} \left(4 \frac{\text{lb}}{\text{ft}} \right) \left(\frac{\pi}{2} (2 \text{ ft}) + 1 \text{ ft} \right)^2 = \underline{34.3 \text{ ft-lb}}$$

$$V_2 = -35 - 5 + 34.3 (\text{ft-lb}) = \underline{-5.7 \text{ ft-lb}}$$

$$T_1 + V_1 + U_{12} = T_2 + V_2$$

$$2 \text{ ft-lb} = 2.58 \omega_2^2 - 5.7 \text{ ft-lb}$$

$$\omega_2 = 1.73 \text{ r/s}$$

EMA 202, Spring 2015
 Final, closed book/notes, 120 min.

Name: _____

Question 3 (25 points)

A completely filled barrel and its contents have a combined mass of 90kg. A cylinder C is connected to the barrel at a height of $h = 550\text{mm}$ as shown. Knowing $\mu_k = 0.35$, determine the maximum mass of C so the barrel will slide and not tip.

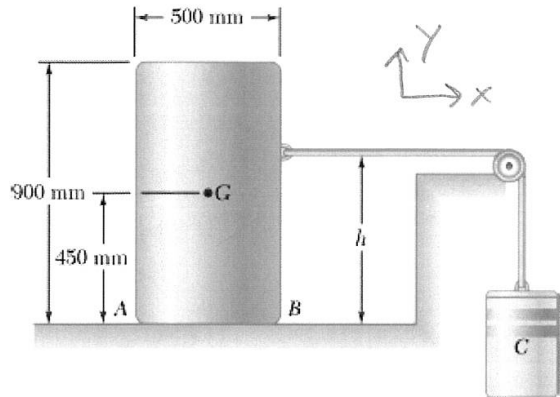

Not tipping $\vec{\alpha}_B = \vec{0}$

inextensible cable

$$a_{Bx} = -a_{Cy}$$

FBD Barrel

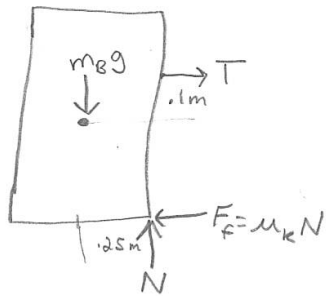

KD

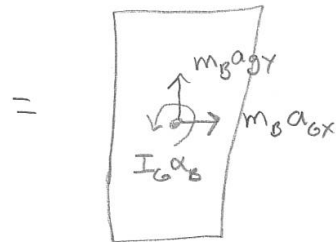

w/ $a_{By} = 0$

$\alpha_B = 0$

FBD mass C

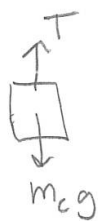

KD

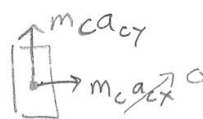

$$\sum F_y = T - m_C g = m_C a_{Cy} \quad \text{with } a_{Cy} = -a_{Bx}$$

$$T = m_C g - m_C a_{Bx} \Rightarrow \boxed{T = m_C (g - a_{Bx})}$$

EMA 202, Spring 2015
Final, closed book/notes, 120 min.

Name: _____

(Additional workspace for Question 3)

Barrel

$$+\uparrow \Sigma F_y = N - m_B g = m_B a_{By} \rightarrow 0$$

$$N = m_B g$$

$$\odot \Sigma M_G = N(.25m) - F_f(.45m) - T(.1m) = I_G \alpha \rightarrow 0$$

$$m_B g (.25m) - \mu_k m_B g (.45m) - T(.1m) = 0$$

$$90 \text{ kg} (9.81 \text{ m/s}^2) (.25m) - .35 \cdot 90 \text{ kg} \cdot 9.81 \text{ m/s}^2 (.45m) - .1T = 0$$

$$T = 816.68 \text{ N}$$

$$\rightarrow \Sigma F_x = T - F_f = m_B a_{Bx}$$

$$816.68 \text{ N} - \mu_k m_B g = m_B a_{Bx}$$

$$816.68 \text{ N} - .35(90)(9.81 \text{ m/s}^2) = 90 \text{ kg} a_{Bx}$$

$$a_{Bx} = 5.64 \text{ m/s}^2$$

plug into ①
from mass C ΣF_y

$$\textcircled{1} T = m_C (g - a_{Bx})$$

$$816.68 \text{ N} = m_C (9.81 \text{ m/s}^2 - 5.64 \text{ m/s}^2)$$

$$m_C = 195.9 \text{ kg}$$

EMA 202, Spring 2015
Final, closed book/notes, 120 min.

Name: _____

Question 4 (25 points)

A 1.5 kg slender rod is welded to a 5 kg uniform disc as shown. The assembly swings freely about C in a vertical plane. Knowing that in the position shown the assembly has an angular velocity of 10 rad/s clockwise, determine

- The angular acceleration of the assembly
- The components of the reaction at C

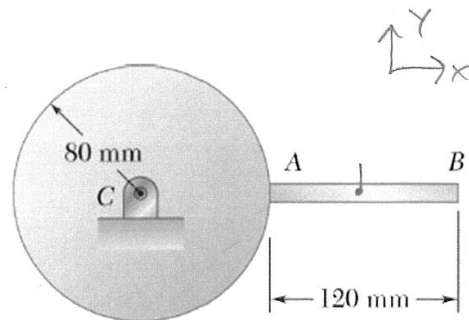

FBD

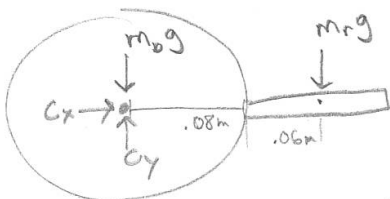

KD

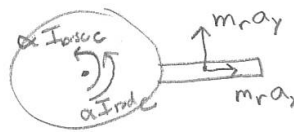

$$A) \quad \curvearrowright \sum M_C = -m_r g \left(r_0 + \frac{L_r}{2} \right) = \alpha I_{disc} + \alpha I_{rod}$$

$$-(1.5 \text{ kg})(9.81 \text{ m/s}^2)(.14 \text{ m}) = \alpha \left(\frac{1}{2} m_d r_0^2 + \frac{1}{12} m_r L_r^2 + m_r \left(r_0 + \frac{L_r}{2} \right)^2 \right)$$

$$-2.06 \text{ Nm} = \alpha \left(\frac{1}{2} (5 \text{ kg})(.08 \text{ m})^2 + \frac{1}{12} (1.5 \text{ kg})(.12 \text{ m})^2 + 1.5 \text{ kg} (.14 \text{ m})^2 \right)$$

$$.0472 (\text{kg} \cdot \text{m}^2)$$

$$\alpha = -43.64 \text{ r/s}^2$$

$$\vec{\alpha} = -43.64 \text{ r/s}^2 \hat{k}$$

EMA 202, Spring 2015
Final, closed book/notes, 120 min.

Name: _____

(Additional workspace for Question 4)

B) Find C_x & C_y

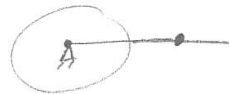

$$\rightarrow \sum F_x = C_x = m_r a_x \quad \text{with } a_x = -a_n = -\omega^2 \left(r_b + \frac{L_r}{2} \right)$$

$$C_x = 1.5 \text{ kg} \left(-(-10 \text{ r/s})^2 \left(0.08 \text{ m} + \frac{0.12 \text{ m}}{2} \right) \right)$$

$$C_x = -21 \text{ N}$$

$$\uparrow \sum F_y = C_y - m_b g - m_r g = m_r a_y \quad \text{with } a_y = \alpha \left(r_b + \frac{L_r}{2} \right)$$

$$C_y - 9.81 \text{ m/s}^2 (5 \text{ kg} + 1.5 \text{ kg}) = 1.5 \text{ kg} (-43.64 \text{ r/s}^2) \left(0.08 \text{ m} + 0.06 \text{ m} \right)$$

$$C_y = 54.6 \text{ N}$$

5.3.2 final Fall 2014

EMA 202, Fall 2014
Final, closed book/notes, 120 min.

Name: _____

Question 1 (25 points)

The 4-kg rod AB is attached to a collar of negligible mass at A and to a flywheel at B. The flywheel has a mass of 16 kg and a radius of gyration of 180 mm. Knowing that in the position shown the angular velocity of the flywheel is 60 rpm clockwise, determine the angular velocity of the flywheel when Point B is directly below C.

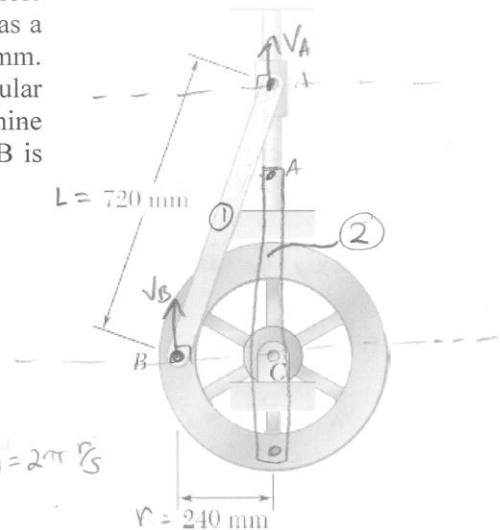

Find ω_2 given

$$m_A = 0$$

$$m_{AB} = 4 \text{ kg}$$

$$m_C = 16 \text{ kg}$$

$$k_C = 180 \text{ mm}$$

$$\omega_1 = 60 \text{ rpm} \left(\frac{2\pi}{60} \right) = 2\pi \text{ rad/s}$$

energy method

$$T_1 + V_1 + U_{12} = T_2 + V_2$$

0, by choice of datum \rightarrow 0, no external F, M

state 1

$$T_1 = T_{1C} + T_{1AB} + T_{1A}$$

disk rod collar

$$T_1 = \frac{1}{2} I_C \omega_{C1}^2 + \frac{1}{2} m_{AB} v_{B1}^2 + \frac{1}{2} I_{G/AB} \omega_{AB1}^2 + \frac{1}{2} m_A v_{A1}^2$$

0, from IC

from IC of AB $\Rightarrow \omega_{AB1} = 0$

$$\vec{v}_{G,AB1} = \vec{v}_{B1} + \vec{\omega}_{AB1} \times \vec{r}_{G/A} \Rightarrow \vec{v}_{G,AB1} = \vec{v}_{B1} = \vec{\omega}_{C1} \times \vec{r}_{BC}$$

$$\vec{v}_{G,AB1} = \omega_{C1} r \hat{j}$$

$$T_1 = \frac{1}{2} (m_C k_C^2) \omega_{C1}^2 + \frac{1}{2} m_{AB} (\omega_{C1} r)^2$$

$$T_1 = \frac{1}{2} (16 \text{ kg} \cdot 180^2 \text{ mm}^2) (2\pi)^2 + \frac{1}{2} (4 \text{ kg}) (2\pi \cdot 240 \text{ mm})^2$$

$$T_1 = 14.78 \text{ N}\cdot\text{m}$$

Q1 Page 4

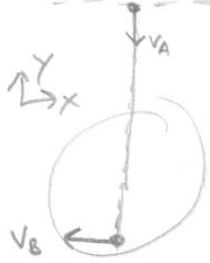
State 2 KE
IC pt A = IC

$$T_2 = \underbrace{\frac{1}{2} I_C \omega_{C2}^2}_{\text{disc}} + \underbrace{\frac{1}{2} m_{AB} v_{G,AB2}^2}_{\text{rod AB}} + \underbrace{\frac{1}{2} I_{G,AB} \omega_{AB2}^2}_{\text{collar A}} + \underbrace{\frac{1}{2} m_A v_{A2}^2}_0$$

IC @ pt A, so rod AB is in pure rotation about A

from AB ① $\vec{v}_B = \vec{v}_A + \vec{\omega}_{AB2} \times \vec{r}_{B/A}$

$$\vec{v}_B = \omega_{AB2} L \hat{i}$$

$$\vec{\omega}_{AB2} = \omega_{AB2} \hat{k}$$

$$\vec{r}_{B/A} = -L \hat{j}$$



from disc ② $\vec{v}_B = \vec{v}_C + \vec{\omega}_{C2} \times \vec{r}_{B/C}$

$$\vec{v}_B = \omega_{C2} r \hat{i}$$

$$\vec{\omega}_{C2} = \omega_{C2} \hat{k}$$

$$\vec{r}_{B/C} = -r \hat{j}$$

Set ①=② for \vec{v}_B

$$\omega_{AB2} L = \omega_{C2} r \rightarrow \boxed{\omega_{AB2} = \omega_{C2} \frac{r}{L}} *$$

find: $\vec{v}_{G,AB2} = \vec{v}_A + \vec{\omega}_{AB2} \times \vec{r}_{G/A}$

$$\vec{r}_{G,AB/A} = -\frac{L}{2} \hat{j}$$

$$\boxed{\vec{v}_{G,AB2} = \omega_{C2} \frac{r}{L} \left(\frac{L}{2}\right) \hat{i} = \omega_{C2} \frac{r}{2} \hat{i}} **$$

Sub * & ** into T_2

$$T_2 = \frac{1}{2} (m_C k_C^2) \omega_{C2}^2 + \frac{1}{2} m_{AB} \frac{r^2}{4} \omega_{C2}^2 + \frac{1}{2} \left(\frac{1}{2} m_{AB} L^2\right) \frac{r^2}{L^2} \omega_{C2}^2$$

$$T_2 = \frac{1}{2} (m_C k_C^2) \omega_{C2}^2 + \frac{1}{6} m_{AB} r^2 \omega_{C2}^2$$

$$\boxed{T_2 = .298 \omega_{C2}^2}$$

Q1 P.3

State 2: PE

$$V_2 = m_{AB} g \Delta h_{ABG}$$

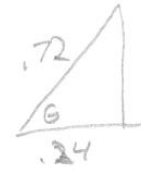
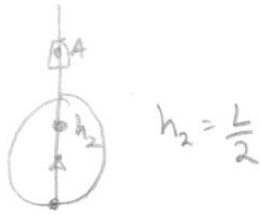
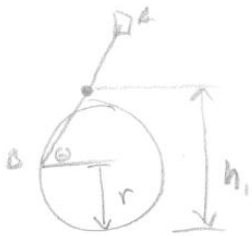

$$\cos \theta = \frac{1.24}{1.72}$$

$$\theta = 70.5^\circ$$

$$h_1 = r + \frac{L}{2} \sin \theta$$

$$\Delta h_{AB} = h_2 - h_1 = \frac{L}{2} - \left(r + \frac{L}{2} \sin \theta \right)$$

$$\Delta h_{AB} = -0.219 \text{ m}$$

$$V_2 = m_{AB} g \Delta h_{AB} = 4(9.81)(-0.219 \text{ m}) = -8.59 \text{ Nm}$$

$$T_1 = T_2 + V_2$$

$$14.78 \text{ Nm} = 0.298 \omega_{c2}^2 - 8.59 \text{ Nm}$$

$$\omega_{c2} = 8.86 \text{ r/s} \quad \curvearrowright$$

EMA 202, Fall 2014
Final, closed book/notes, 120 min.

Name: _____

Question 2 (25 points)

The crane's telescopic boom rotates with the angular velocity and angular acceleration shown. At the same instant, the boom is extending with a constant speed of 0.5 ft/s, measured relative to the boom. Determine the velocity and acceleration vectors of point B in the XY coordinate system given.

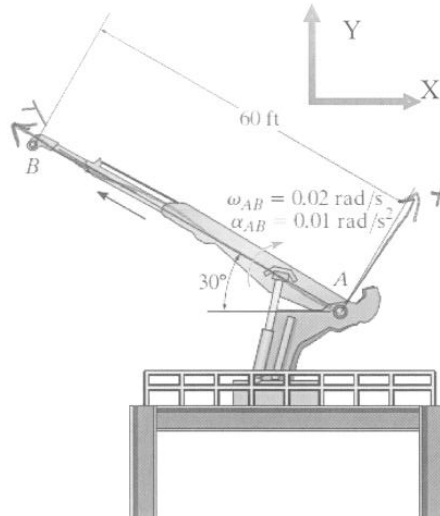

find \vec{v}_{BXY} & \vec{a}_{BXY}

fix rotating CS @ pt A

$$\vec{v}_B = \vec{v}_A + \vec{\omega}_{AB} \times \vec{r}_{BA} + \vec{v}_{Brel}$$

$$\vec{v}_B = \omega_{AB} r_{BA} \hat{i} + 0.5 \hat{j}$$

$$\vec{v}_B = (0.02)60 \text{ ft} \hat{i} + 0.5 \text{ ft/s} \hat{j}$$

$$xy \quad \vec{v}_B = 1.2 \hat{i} + 0.5 \hat{j} \text{ ft/s}$$

$$\vec{v}_{Brel} = 0.5 \text{ ft/s} \hat{j}$$

$$\vec{\omega}_{AB} = -0.02 \text{ rad/s} \hat{k}$$

$$\vec{r}_{BA} = 60 \text{ ft} \hat{i}$$



Convert back to XY coords

$$\hat{i} = \sin 30 \hat{I} + \cos 30 \hat{J}$$

$$\hat{j} = -\cos 30 \hat{I} + \sin 30 \hat{J}$$

$$XY \quad \vec{v}_B = 1.2 (\sin 30 \hat{I} + \cos 30 \hat{J}) + 0.5 (-\cos 30 \hat{I} + \sin 30 \hat{J}) \text{ ft/s}$$

$$\boxed{\vec{v}_B = 0.167 \hat{I} + 1.289 \hat{J} \text{ ft/s}}$$

Q2 page 2

$$\vec{a}_B = \underbrace{\vec{a}_A}_{O, \text{ pinned}} + \vec{\alpha}_{AB} \times \vec{r}_{B/A} + \underbrace{\vec{\omega}_{AB} \times (\vec{\omega}_{AB} \times \vec{r}_{B/A})}_{-\omega_{AB}^2 \vec{r}_{B/A}} + 2\vec{\omega}_{AB} \times \vec{v}_{B \text{ rel}} + \underbrace{\vec{a}_{B \text{ rel}}}_{O, \text{ constant } v_{B \text{ rel}}}$$

$$\vec{\alpha}_{AB} = \alpha_{AB} \hat{k} = -.01 \hat{k} \text{ } \uparrow / \text{s}^2$$

$$\vec{a}_B = -.01 \hat{k} \times 60 \text{ ft } \hat{j} - (.02)^2 60 \hat{j} + 2(.02 \hat{k}) \times .5 \hat{j}$$

$$\vec{a}_B = 60(.01) \uparrow - .02^2 \cdot 60 \hat{j} + 2(.02) \cdot .5 \uparrow$$

$$xy \quad \vec{a}_B = .62 \uparrow - .024 \hat{j} \text{ } \uparrow / \text{s}^2$$

in XY

$$\vec{a}_B = .62 (\sin 30 \hat{i} + \cos 30 \hat{j}) - .024 (-\cos 30 \hat{i} + \sin 30 \hat{j}) \text{ } \uparrow / \text{s}^2$$

$$\vec{a}_B = .331 \hat{i} + .525 \hat{j} \text{ } \uparrow / \text{s}^2$$

EMA 202, Fall 2014
Final, closed book/notes, 120 min.

Name: _____

Question 3 (25 points)

A merry go round with a rider ($m=20\text{kg}$) is initially rotating at a rate of 5 rad/s about point A. Someone pushes the merry go round with an average force of $F=100\text{N}$ for 5 seconds. During that time the rider moves from the edge of the merry go round to a position 0.5 meters from the center. The angular velocity after the push is 10 rad/s .

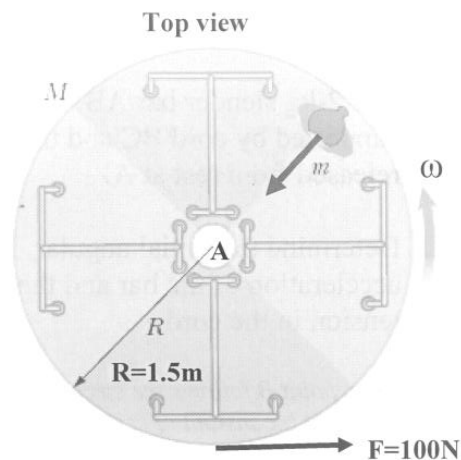

Determine the mass of the merry go round assuming it can be modeled as a circular disk.

Given

$$\vec{\omega}_1 = 5 \text{ rad/s } \hat{k}$$

$$\vec{\omega}_2 = 10 \text{ rad/s } \hat{k}$$

$$m_r = 20 \text{ kg}$$

$$F_{\text{ave}} = 100 \text{ N for } 5 \text{ seconds}$$

$$R = 1.5 \text{ m}$$

moment of inertia

$$I_{A1} = I_D + m_r R^2$$

$$I_{\text{disk}} = \frac{1}{2} m_D R^2$$

$$I_{A1} = \frac{1}{2} m_D R^2 + m_r R^2$$

$$I_{A2} = \frac{1}{2} m_D R^2 + m_r (0.5 \text{ m})^2$$

Angular momentum - Impulse

$$I_{A1} \vec{\omega}_1 + \int \vec{M} dt = I_{A2} \vec{\omega}_2$$

$$\vec{M} = \vec{r} \times \vec{F} = 1.5 \text{ m} (100 \text{ N}) \hat{k}$$

$$\left(\frac{1}{2} m_D (1.5)^2 + 20 \text{ kg} (1.5^2) \right) 5 \text{ rad/s } \hat{k} + \int_0^{5 \text{ sec}} 150 \text{ Nm} dt = \left(\frac{1}{2} m_D (1.5)^2 + 20 (0.5 \text{ m})^2 \right) 10 \text{ rad/s } \hat{k}$$

Q3 page 2

$$5.625 m_D + 225 \frac{\text{kg} \cdot \text{m}^2}{\text{s}} + 150 \text{Nm}(5 \text{sec}) = 11.25 \frac{\text{kg} \cdot \text{m}^2}{\text{s}} (m_D) + 50 \frac{\text{kg} \cdot \text{m}^2}{\text{s}}$$

$$225 + 50 + 750 = (11.25 - 5.625) m_D$$

$$m_D = 164.4 \text{ kg}$$

EMA 202, Fall 2014
Final, closed book/notes, 120 min.

Name: _____

Question 4 (25 points)

The 2-kg slender bar AB is supported by cord BC and then released from rest at A.

Determine the initial angular acceleration of the bar and the tension in the cord.

Hint: point B follows the circular path shown at the instant of release

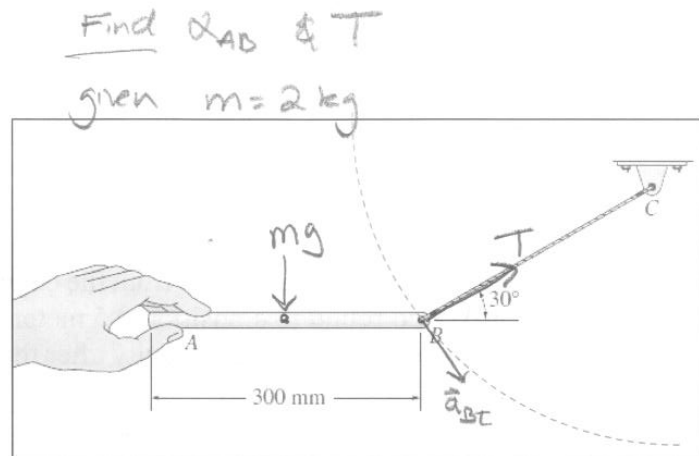

$$\underline{NT} \quad \vec{a}_B = a_{BN} \hat{u}_N + a_{Bt} \hat{u}_t$$

$$a_{BN} = \frac{v_B^2}{\rho}, \text{ with } v_B = 0 \text{ @ release}$$

$$\vec{a}_B = a_{Bt} \hat{u}_t \rightarrow \textcircled{1} \left[\vec{a}_B = a_B \sin \theta \hat{i} - a_B \cos \theta \hat{j} \right]$$

$$\rightarrow \sum F_x = T \cos 30^\circ = m a_{Gx}$$

$$+\uparrow \sum F_y = -mg + T \sin 30^\circ = m a_{Gy}$$

$$\curvearrowright \sum M_G = T \sin 30^\circ \left(\frac{L}{2} \right) = I_G \alpha_{AB}$$

3 eqns 4 unknowns

→ use what we know about \vec{a}_B to eliminate a variable

accel @ B

$$\vec{a}_B = \vec{a}_G + \vec{\alpha}_{AB} \times \vec{r}_{B/G} \quad \vec{r}_{B/G} = \frac{0.3}{2} \hat{i} \text{ (m)}$$

$$\textcircled{2} \quad \vec{a}_B = a_{Gx} \hat{i} + a_{Gy} \hat{j} + \frac{0.3}{2} \alpha \hat{j}$$

set i & j components from $\textcircled{1} = \textcircled{2}$

$$i) \quad a_B \sin \theta = a_{Gx}$$

$$j) \quad -a_B \cos \theta = a_{Gy} + \frac{0.3}{2} \alpha$$

Q4 page 2

i) $a_{Gx} = a_B \sin \theta$, $\theta = 30^\circ$

j) $a_{Gy} = -a_B \cos \theta - .15 \alpha$

back to ΣF & ΣM

X) $T \cos 30 = m(a_B \sin \theta)$ $a_B = \frac{T}{m \tan 30}$

Y) $T \sin 30 - mg = m(-a_B \cos \theta - .15 \alpha)$

$$\frac{T \sin 30 - mg}{m} = \frac{-T \cos 30}{m \tan 30} - .15 \alpha$$

$$\frac{T}{m} \left(\frac{\sin 30 + \frac{\cos^2 30}{\sin 30}}{\sin 30} \right) = g - .15 \alpha$$

$$\frac{\sin^2 30 + \cos^2 30}{\sin 30} = \frac{1}{\sin 30} = 2$$

$$\boxed{T = g - .15 \alpha}$$

M_G) $T \sin 30 \left(\frac{L}{2} \right) = \frac{1}{2} mL^2 \alpha_{AB}$ $\forall I_G = \frac{1}{2} mL^2$

$$(g - .15 \alpha) \frac{L}{4} = \frac{1}{2} mL^2 \alpha_{AB}$$

$$\frac{gL}{4} = \left(\frac{1}{12} mL^2 + \frac{.15L}{4} \right) \alpha_{AB}$$

$$\frac{(9.81 \text{ m/s}^2)(.3 \text{ m})}{4} = \left(\frac{1}{12} (2 \text{ kg})(.3 \text{ m})^2 + \frac{.15(.3 \text{ m})}{4} \right) \alpha_{AB}$$

$$\boxed{\alpha_{AB} = 28.03 \text{ r/s}^2}$$

$$T = g - .15 \alpha \Rightarrow \boxed{T = 5.61 \text{ N}}$$

5.3.3 PERP practice exam Fall 2017

Name: KEYPrEPS Practice Exam 2
Fall 2017

3. The pendulum consists of a disk of weight W_1 and a slender rod of weight W_2 .

$$W_1 = 15 \text{ lb}$$

$$W_2 = 10 \text{ lb}$$

$$a = 0.75 \text{ ft}$$

$$b = 3 \text{ ft}$$

$$\omega = 8 \frac{\text{rads}}{\text{s}}$$

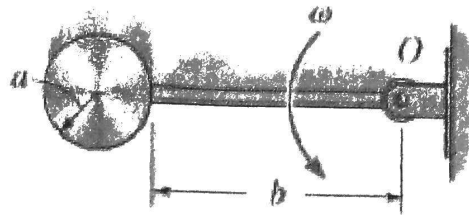

Determine:

- A) Knowing the disk and the rod are rigidly attached, find the mass moment of Inertia about point O .
- B) Determine the horizontal and vertical components of reaction that the pin O exerts on the rod just as it passes the horizontal position, at which time its angular velocity is ω .

$$a) \quad I_O = I_{O, \text{rod}} + I_{O, \text{disk}}$$

$$I_{O, \text{rod}} = I_{\text{rod, end}} = \frac{1}{3} m L^2 = \frac{1}{3g} W_2 b^2$$

$$I_{O, \text{disk}} = I_{\text{disk}} + m d^2 = \frac{1}{2} m r^2 + m d^2 = \frac{1}{2g} W_1 a^2 + \frac{W_1}{g} (a+b)^2$$

$$I_O = \frac{1}{g} \left[\frac{W_2 b^2}{3} + \frac{W_1 a^2}{2} + W_1 (a+b)^2 \right]$$

$$I_O = 7.613 \text{ slug} \cdot \text{ft}^2$$

b) FBD

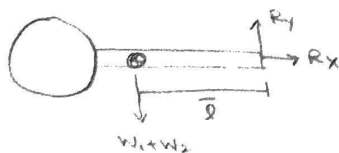

KBD

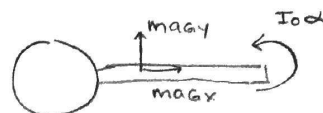

Name: KEYPrEPS Practice Exam 2
Fall 2017

$$(1) \Sigma F_x: R_x = m a_{Gx}$$

$$(2) \Sigma F_y: R_y - W_1 - W_2 = m a_{Gy}$$

$$(3) \Sigma M_o: (W_1 + W_2) \bar{l} = I_o \alpha$$

$$\bar{l} = \frac{\frac{W_2 b}{2} + W_1 (a+b)}{W_1 + W_2}$$

$$\bar{l} = 2.85 \text{ ft}$$

3 equations, 5 unknowns ($a_{Gx}, a_{Gy}, R_y, R_x, \alpha$)
Kinematics for last two equations

$$\vec{a}_G = \vec{\alpha} \times \vec{r}_{G/o} - \omega^2 \vec{r}_{G/o}$$

$$a_{Gx} \hat{i} + a_{Gy} \hat{j} = (\alpha \hat{k} \times -\bar{l} \hat{i}) - \omega^2 (-\bar{l} \hat{i})$$

$$a_{Gx} \hat{i} + a_{Gy} \hat{j} = -\alpha \bar{l} \hat{j} + \omega^2 \bar{l} \hat{i}$$



$$(4) \hat{i}: a_{Gx} = \omega^2 \bar{l}$$

$$(5) \hat{j}: a_{Gy} = -\alpha \bar{l}$$

From (1) and (4)

$$R_x = m \omega^2 \bar{l} = \left[\frac{W_1 + W_2}{g} \right] \omega^2 \bar{l}$$

$$R_x = 141.615 \text{ lbs}$$

Put (3) into (5) and then (5) into (2)

$$\alpha = \frac{(W_1 + W_2) \bar{l}}{I_o} \quad \alpha = 9.358 \text{ rad/s}^2$$

$$R_y = W_1 + W_2 + \left[\frac{W_1 + W_2}{g} \right] [-\alpha \bar{l}]$$

$$R_y = 4.291 \text{ lbs}$$

Name: KEYPrEPS Practice Exam 2
Fall 2017

2. The pendulum consists of 2-lb rod BA and a 6 lb disk. The spring is stretched 0.3 ft when the rod is horizontal as shown. When the pendulum is released, it rotates about bearing D . The roller at C allows the spring to remain vertical as the rod falls.

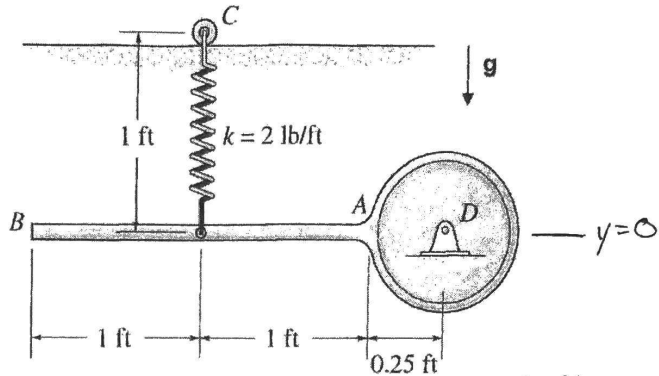

- (a) If released from rest, determine the pendulum's angular velocity at the instant the rod becomes vertical.

- (b) Suppose we now add a torsional spring of strength k_t to the bearing at D . The torsional spring provides a restoring moment in much the same way as a linear spring provides a restoring force. It has an associated potential function of $V_t = \frac{1}{2} k_t \theta^2$, where θ is the angular displacement of the rod from its horizontal position. What value should k_t have so that the pendulum comes to rest again after displacing 45° ?

$$W_{\text{rod}} = 2 \text{ lb} \quad L_0 = 0.7 \text{ ft} \quad R = 0.25 \text{ ft}$$

$$W_{\text{disk}} = 6 \text{ lb} \quad L_{AB} = 2 \text{ ft}$$

$$T_1 + V_1 = T_2 + V_2$$

$$T_1 = 0 \quad V_1 = \frac{1}{2} k \delta_1^2$$

$$T_2 = \frac{1}{2} m v_G^2 + \frac{1}{2} I_G \omega^2 = \frac{1}{2} I_D \omega^2$$

$$I_D = I_{\text{disk},G} + I_{\text{rod},G} + m_{\text{rod}} d_{G/B}^2$$

$$I_D = \frac{1}{2} m_{\text{disk}} R^2 + \frac{1}{12} m_{\text{rod}} L_{AB}^2 + m_{\text{rod}} \left(\frac{L_{AB}}{2} + R \right)^2$$

$$V_2 = \frac{1}{2} k \delta_2^2 + m_{\text{rod}} g \Delta H_{\text{rod},G}$$

$$\frac{1}{2} k \delta_1^2 = \frac{1}{2} \left[\frac{1}{2} \cdot \frac{W_{\text{disk}}}{g} \cdot R^2 + \frac{W_{\text{rod}}}{g} \left(\frac{1}{12} L_{AB}^2 + \left(\frac{L_{AB}}{2} + R \right)^2 \right) \right] \omega^2 + \frac{1}{2} k \delta_2^2 + \frac{W_{\text{rod}}}{g} g \Delta H_{\text{rod},G}$$

$$\delta_1 = 0.3 \text{ ft}$$

$$\delta_2 = \delta_1 + \frac{L_{AB}}{2} + R = 1.55 \text{ ft}$$

$$\Delta H_{\text{rod}} = - \left(\frac{L_{AB}}{2} + R \right) = -1.25 \text{ ft}$$

$$\frac{1}{2} (2 \frac{\text{lb}}{\text{ft}}) ((0.3 \text{ ft})^2 - (1.55 \text{ ft})^2) + (2 \text{ lb})(1.25 \text{ ft}) = \frac{1}{2} \left[\frac{1}{2} \cdot \frac{6 \text{ lb}}{32.2 \frac{\text{ft}}{\text{s}^2}} (.25 \text{ ft})^2 + \frac{2 \text{ lb}}{32.2 \frac{\text{ft}}{\text{s}^2}} \left(\frac{(2 \text{ ft})^2}{12} + \left(\frac{2 \text{ ft}}{2} + .25 \text{ ft} \right)^2 \right) \right] \omega^2$$

$$.1875 = .0618 \cdot \omega^2$$

$$\boxed{\omega = 1.742 \frac{\text{rad}}{\text{s}}}$$

Name: KEYPrEPS Practice Exam 2
Fall 2017

$$T_1 + V_1 = T_2 + V_2$$

$$T_1 = 0 \quad T_2 = 0$$

$$V_1 = \frac{1}{2} k \delta_1^2 \quad V_2 = \frac{1}{2} k \delta_2^2 + \frac{1}{2} k_t \theta^2 + m_{\text{rod}} g \Delta H_{\text{rod},6}$$

$$\delta_1 = 0.3 \text{ ft}$$

$$\delta_2 = 0.3 \text{ ft} + \left(\frac{L_{AB}}{2} + R \right) \sin 45^\circ = 1.184 \text{ ft}$$

$$\Delta H_{\text{rod},6} = - \left(\frac{L_{AB}}{2} + R \right) \sin 45^\circ = -0.8838 \text{ ft}$$

$$\frac{1}{2} k \delta_1^2 = \frac{1}{2} k \delta_2^2 + \frac{1}{2} k_t \theta^2 + W_{\text{rod}} \Delta H_{\text{rod},6}$$

$$\frac{\frac{1}{2} k (\delta_1^2 - \delta_2^2) - W_{\text{rod}} \Delta H_{\text{rod},6}}{\frac{1}{2} \theta^2} = k_t$$

$$k_t = \frac{(2 \frac{16}{\text{ft}}) ((0.3 \text{ ft})^2 - (1.184 \text{ ft})^2) - 2(2/16)(-0.8838 \text{ ft})}{(\pi/4 \text{ rad})^2}$$

$$k_t = 1.479 \text{ lb-ft}$$

Name: KEY

PrEPS Practice Exam 2
Fall 2017

3. The double pulley D has a mass of 15kg, center of mass G coinciding with its geometric center, radius of gyration $k_G = 10\text{cm}$, outer radius $r_o = 15\text{cm}$, and inner radius $r_i = 7.5\text{cm}$. It is connected to the pulley P with radius R via a cord of negligible mass that unwinds from the inner and outer spools of the double pulley D . The crate C , which has a mass of 20kg, is released from rest.

Assuming the pulley P has a mass of 1.5 kg and a radius of gyration $k_G = 3.5\text{cm}$, determine the speed of the crate C and the angular velocity of pulley D after the crate has dropped a distance $h = 2\text{m}$

$m_D = 15\text{ kg}$ $r_o = 15\text{ cm}$ $m_C = 20\text{ kg}$ $k_{G,P} = 3.5\text{ cm}$
 $k_{G,D} = 10\text{ cm}$ $r_i = 7.5\text{ cm}$ $m_P = 1.5\text{ kg}$ $h = 2\text{ m}$

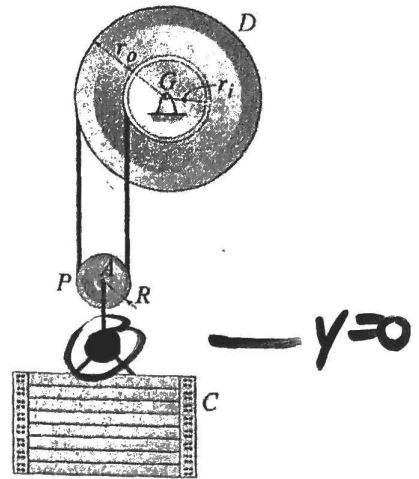

$$T_1 + V_1 = T_2 + V_2$$

$$T_1 = 0 \quad T_2 = \frac{1}{2} I_D \omega_D^2 + \frac{1}{2} m_P v_{G,P}^2 + \frac{1}{2} I_P \omega_P^2 + \frac{1}{2} m_C v_C^2$$

$$V_1 = 0 \quad V_2 = -(m_P + m_C) h g$$

$$I_D = m_D k_{G,D}^2$$

$$I_P = m_P k_{G,P}^2$$

find: ω_D ω_P v_P v_C

$$v_P = v_C \quad \checkmark$$

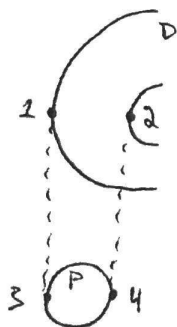

$$v_1 = \omega_D r_o = v_3 \quad v_2 = \omega_D r_i = v_4$$

$$v_P = \frac{1}{2} (v_3 + v_4)$$

$$v_P = v_3 + \omega_P \times \vec{r}_{P/3} = v_4 + \omega_P \times \vec{r}_{P/4} \stackrel{\pm}{=} \omega_D r_o + \omega_D \cdot \frac{1}{2} (r_o - r_i) = \omega_D (r_i + r_o) \cdot \frac{1}{2}$$

$$v_3 + \omega_P R = v_4 + \omega_P (-R)$$

$$2 \omega_P R = v_4 - v_3$$

$$\omega_P = \frac{v_4 - v_3}{2R} = \frac{\omega_D r_o - \omega_D r_i}{2(\frac{1}{2})(r_o - r_i)} = \frac{\omega_D (r_o - r_i)}{r_o - r_i} = \omega_D$$

Problem 3 Kinematics

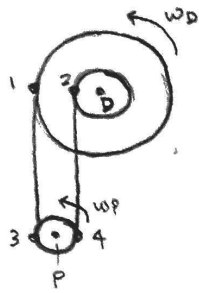

$$\vec{v}_1 = \vec{v}_D + \vec{\omega}_D \times \vec{r}_{1/D}$$

$$\vec{v}_1 = \omega_D \hat{k} \times -r_0 \hat{i}$$

$$\vec{v}_1 = -\omega_D r_0 \hat{j}$$

$$\vec{v}_2 = \vec{v}_D + \vec{\omega}_D \times \vec{r}_{2/D}$$

$$\vec{v}_2 = \omega_D \hat{k} \times -r_i \hat{i}$$

$$\vec{v}_2 = -\omega_D r_i \hat{j}$$

$$\vec{v}_1 = \vec{v}_3$$

$$\text{and } \vec{v}_2 = \vec{v}_4$$

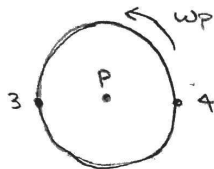

Let the distance between 3 and 4 be $r_0 - r_i$

$$\vec{v}_4 = \vec{v}_3 + \vec{\omega}_P \times \vec{r}_{4/3}$$

$$-\omega_D r_i \hat{j} = -\omega_D r_0 \hat{j} + \omega_P \hat{k} \times (r_0 - r_i) \hat{i}$$

$$-\omega_D r_i \hat{j} = -\omega_D r_0 \hat{j} + \omega_P (r_0 - r_i) \hat{j}$$

$$\omega_D (r_0 - r_i) = \omega_P (r_0 - r_i)$$

$$\therefore \boxed{\omega_D = \omega_P}$$

$$\vec{v}_P = \vec{v}_3 + \vec{\omega}_P \times \vec{r}_{P/3}$$

$$\vec{v}_P = -\omega_D r_0 \hat{j} + \omega_D \hat{k} \times \frac{(r_0 - r_i)}{2} \hat{i}$$

$$\vec{v}_P = \left[-\omega_D r_0 + \omega_D \frac{(r_0 - r_i)}{2} \right] \hat{j}$$

$$\vec{v}_P = \frac{-2\omega_D r_0 + \omega_D r_0 - \omega_D r_i}{2}$$

$$\boxed{\vec{v}_P = \frac{-\omega_D (r_0 + r_i)}{2}}$$

$$\vec{v}_P = \vec{v}_C$$

Knowing $\omega_D = \omega_P$ and $v_P = \frac{\omega_D (r_o + r_i)}{2}$ and $v_C = v_P$

$$0 = T_2 + V_2$$

$$0 = \frac{1}{2} I_D \omega_D^2 + \frac{1}{2} m_P v_P^2 + \frac{1}{2} I_P \omega_P^2 + \frac{1}{2} m_C v_C^2 - (m_P + m_C) h g$$

$$2(m_P + m_C) h g = m_D K_{G,D}^2 \omega_D^2 + m_P \frac{\omega_D^2 (r_o + r_i)^2}{4} + m_P K_{G,P}^2 \omega_D^2 + m_C \frac{\omega_D^2 (r_o + r_i)^2}{4}$$

$$2(m_P + m_C) h g = \omega_D^2 \left[m_D K_{G,D}^2 + m_P K_{G,P}^2 + \frac{(m_P + m_C) (r_o + r_i)^2}{4} \right]$$

$$\omega_D = \sqrt{\frac{2(m_P + m_C) h g}{m_D K_{G,D}^2 + m_P K_{G,P}^2 + \frac{(m_P + m_C) (r_o + r_i)^2}{4}}}$$

$$\omega_D = 44.61 \frac{\text{rad}}{\text{s}}$$

Since $v_C = v_P = \frac{\omega_D (r_o + r_i)}{2}$

$$v_C = 5.019 \text{ m/s}$$

Chapter 6

HWs

Local contents

6.1	HW 1	160
6.2	HW 2	163
6.3	HW 3	169
6.4	HW 4	174
6.5	HW 5	181
6.6	HW 6	187
6.7	HW 7	193
6.8	HW 8	198
6.9	HW 9	206
6.10	HW 10	212
6.11	HW 11	222
6.12	HW 12	229
6.13	HW 13	238

6.1 HW 1

Your response:

Do not round intermediate calculations, however for display purposes report intermediate steps rounded to four significant figures. Give your final answer(s) to three significant figures.

The position of a car traveling between two stop signs along a straight city block is given by $r = [8t - (45/2)\sin(2t/7)]$ m, where t denotes the time and $0 \text{ s} \leq t \leq 17.8 \text{ s}$. Compute the displacement of the car between 2.1 and 3.6 s, as well as between 11.1 and 12.6 s. For each of these time intervals, compute the average velocity of the car.



$$\Delta r_1 = \boxed{5.432} \checkmark \text{ m}$$

$$\Delta r_2 = \boxed{21.286} \checkmark \text{ m}$$

$$(v_{\text{avg}})_1 = \boxed{3.621} \checkmark \text{ m/s}$$

$$(v_{\text{avg}})_2 = \boxed{14.190} \checkmark \text{ m/s}$$

The motion of a stone thrown into a pond is described by

$$\vec{r}(t) = \left[\left(1.5 - 0.4e^{-13.5t} \right) \hat{i} + \left(0.096e^{-13.5t} - 0.096 - 0.75t \right) \hat{j} \right] \text{ m, where } t \text{ is time}$$

expressed in s, and $t = 0 \text{ s}$ is the time when the stone first hits the water. Determine the stone's velocity and acceleration. In addition, find the initial angle of impact θ of the stone with the water, i.e., the angle formed between the stone's trajectory and the x axis at $t = 0 \text{ s}$.

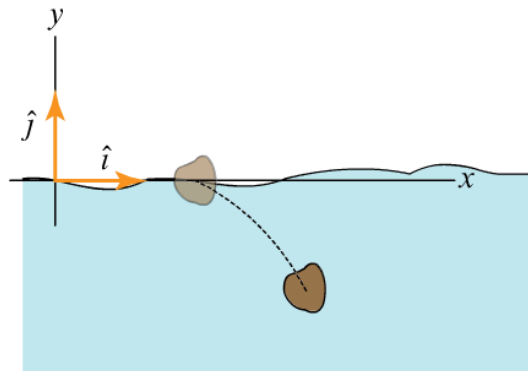

$$\mathbf{v}(t) = \dot{\mathbf{r}}(t) = \left[\left(\boxed{5.4} \checkmark e^{-13.5t} \right) \hat{i} + \left(\boxed{-0.75} \checkmark \boxed{1.296} \checkmark e^{-13.5t} \right) \hat{j} \right] \text{ m/s}$$

$$\mathbf{a}(t) = \dot{\mathbf{v}}(t) = \left[\left(\boxed{-72.9} \checkmark e^{-13.5t} \right) \hat{i} + \left(\boxed{17.496} \checkmark e^{-13.5t} \right) \hat{j} \right] \text{ m/s}^2$$

$$\theta = \boxed{20.776} \times$$

A 1.7 kg rock is released from rest at the surface of a calm lake. If the resistance offered by the water as the rock falls is directly proportional to the rock's velocity, the rock's acceleration is $a = g - C_d v/m$, where g is the acceleration of gravity, C_d is a constant drag coefficient, v is the rock's velocity, and m is the rock's mass. Letting $C_d = 4.1$ kg/s, determine the rock's velocity after 1.9 s.

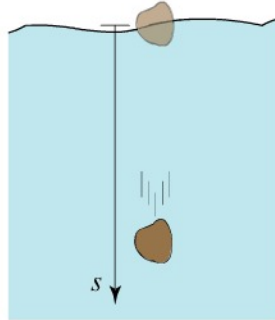

$$v_f = \boxed{4.026} \text{ m/s}$$

The acceleration of a particle of mass m suspended by a linear spring with spring constant k and unstretched length L_0 (when the spring length is equal to L_0 , the spring exerts no force on the particle) is given by $\ddot{x} = g - (k/m)(x - L_0)$. Let $k = 101$ N/m, $m = 0.8$ kg, and $L_0 = 0.78$ m. If the particle is released from rest at $x = 0$ m, determine the maximum length achieved by the spring.

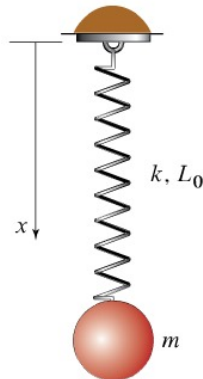

$$x_{\max} = \boxed{1.715} \text{ m}$$

The jaguar A leaps from O at speed $v_0 = 6.4$ m/s and angle $\beta = 38^\circ$ relative to the incline to try to intercept the panther B at C . Determine the distance R that the jaguar jumps from O to C (i.e. R is the distance between the two points of the trajectory that intersect the incline), given that the angle of the incline is $\theta = 20^\circ$.

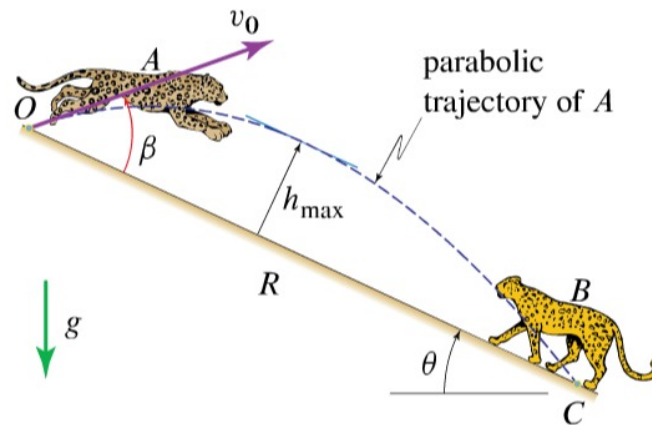

$$R = \boxed{5.537} \text{ m}$$

In a movie scene involving a car chase, a car goes over the top of a ramp at A and lands at B below. Determine the speed of the car at A if the car is to cover distance $d = 170$ ft for $\alpha = 23^\circ$ and $\beta = 32^\circ$. Neglect aerodynamic effects.

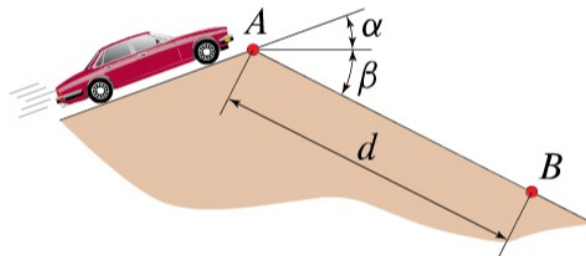

$$v_0 = \boxed{51.093} \text{ m/s}$$

6.2 HW 2

6.2.1 Problem 1

The radar station at O is tracking the meteor P as it moves through the atmosphere. At the instant shown, the station measures the following data for the motion of the meteor: $r = 21,000$ ft, $\theta = 38^\circ$, $\dot{r} = -22,490$ ft/s, and $\dot{\theta} = -2.933$ rad/s. Determine the magnitude and direction (relative to the x coordinate system shown) of the velocity vector at this instant.

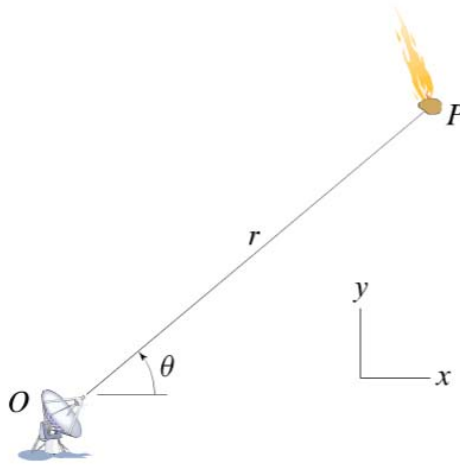

The magnitude of the velocity is ft/s.

Direction of the velocity relative to the x axis is °.

$$\bar{v} = \dot{r}\hat{u}_r + r\dot{\theta}\hat{u}_\theta$$

Hence

$$\begin{aligned} |\bar{v}| &= \sqrt{\dot{r}^2 + (r\dot{\theta})^2} \\ &= \sqrt{(-22490)^2 + (21000 \times (-2.933))^2} \\ &= 65571 \text{ ft/sec} \end{aligned}$$

Since

$$\begin{aligned} \hat{u}_r &= \hat{i} \cos \theta + \hat{j} \sin \theta \\ \hat{u}_\theta &= -\hat{i} \sin \theta + \hat{j} \cos \theta \end{aligned}$$

Then the velocity vector in Cartesian is

$$\begin{aligned} \bar{v} &= \dot{r}(\hat{i} \cos \theta + \hat{j} \sin \theta) + r\dot{\theta}(-\hat{i} \sin \theta + \hat{j} \cos \theta) \\ &= \hat{i}(\dot{r} \cos \theta - r\dot{\theta} \sin \theta) + \hat{j}(\dot{r} \sin \theta + r\dot{\theta} \cos \theta) \end{aligned}$$

Plug-in numerical values

$$\begin{aligned} \bar{v} &= \hat{i} \left(-22490 \cos \left(38 \left(\frac{\pi}{180} \right) \right) - (21000)(-2.933) \sin \left(38 \left(\frac{\pi}{180} \right) \right) \right) \\ &\quad + \hat{j} \left((-22490) \sin \left(38 \left(\frac{\pi}{180} \right) \right) + (21000)(-2.933) \cos \left(38 \left(\frac{\pi}{180} \right) \right) \right) \end{aligned}$$

Or

$$\bar{v} = (20198.08)\hat{i} - \hat{j}(62382.17)$$

To check, we find magnitude of \bar{v} in Cartesian

$$|\bar{v}| = \sqrt{(20198.08)^2 + (62382.17)^2} = 65571$$

Which is the same as before. Hence the velocity vector makes angle $\tan^{-1} \left(\frac{-62382}{20198} \right) = -1.2577$ rad or $-1.2577 \left(\frac{180}{\pi} \right) = -72.061$ degrees with the x -axis.

6.2.2 Problem 2

The radar station at O is tracking the meteor P as it moves through the atmosphere. At the instant shown, the station measures the following data for the motion of the meteor:

$r = 21,400$ ft, $\theta = 44^\circ$, $\dot{r} = -22,490$ ft/s, $\dot{\theta} = -2.944$ rad/s, $\ddot{r} = 187,300$ ft/s², and $\ddot{\theta} = -5.407$ rad/s². Determine the magnitude and direction (relative to the xy coordinate system shown) of the acceleration vector at this instant.

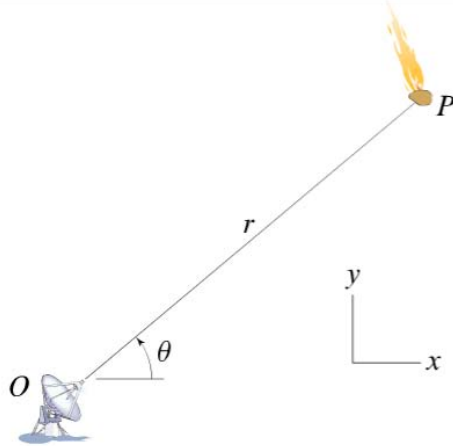

The magnitude of the acceleration is ft/s².

Direction of the acceleration relative to the x axis is ° CCW from the horizontal.

$$\bar{a} = (\ddot{r} - r\dot{\theta}^2) \hat{u}_r + (r\ddot{\theta} + 2\dot{r}\dot{\theta}) \hat{u}_\theta$$

Hence

$$\begin{aligned} |\bar{a}| &= \sqrt{(\ddot{r} - r\dot{\theta}^2)^2 + (r\ddot{\theta} + 2\dot{r}\dot{\theta})^2} \\ &= \sqrt{(187300 - (21400)(-2.944)^2)^2 + ((21400)(-5.407) + 2(-22490)(-2.944))^2} \\ &= 16810.49 \text{ ft/sec}^2 \end{aligned}$$

Since

$$\begin{aligned} \hat{u}_r &= \hat{i} \cos \theta + \hat{j} \sin \theta \\ \hat{u}_\theta &= -\hat{i} \sin \theta + \hat{j} \cos \theta \end{aligned}$$

Then the acceleration vector in Cartesian is

$$\begin{aligned} \bar{a} &= (\ddot{r} - r\dot{\theta}^2) (\hat{i} \cos \theta + \hat{j} \sin \theta) + (r\ddot{\theta} + 2\dot{r}\dot{\theta}) (-\hat{i} \sin \theta + \hat{j} \cos \theta) \\ &= \hat{i} ((\ddot{r} - r\dot{\theta}^2) \cos \theta - (r\ddot{\theta} + 2\dot{r}\dot{\theta}) \sin \theta) + \hat{j} ((\ddot{r} - r\dot{\theta}^2) \sin \theta + (r\ddot{\theta} + 2\dot{r}\dot{\theta}) \cos \theta) \end{aligned} \quad (1)$$

But

$$\begin{aligned} (\ddot{r} - r\dot{\theta}^2) &= (187300 - (21400)(-2.944)^2) = 1823.290 \\ (r\ddot{\theta} + 2\dot{r}\dot{\theta}) &= ((21400)(-5.407) + 2(-22490)(-2.944)) = 16711.32 \end{aligned}$$

Hence (1) becomes

$$\begin{aligned} \bar{a} &= \hat{i} \left(1823.290 \cos \left(44 \frac{\pi}{180} \right) - (16711.32) \sin \left(44 \frac{\pi}{180} \right) \right) \\ &\quad + \hat{j} \left(1823.290 \sin \left(44 \frac{\pi}{180} \right) + (16711.32) \cos \left(44 \frac{\pi}{180} \right) \right) \\ &= \hat{i}(-10297.09) + \hat{j}(13287.68) \end{aligned}$$

To verify things, we check the magnitude of \bar{a} is the same as found above (since the magnitude of vector does not depend on coordinates. We see that $|\bar{a}| = \sqrt{(-10297.09)^2 + (13287.68)^2} = 16810.49$ which is the same as before.

Hence the acceleration vector makes angle $\tan^{-1}\left(\frac{13287.68}{-10297.09}\right) = 127.7$ degrees with the x-axis.

6.2.3 Problem 3

A jet is flying at a constant speed $v_0 = 750$ mph while performing a constant speed circular turn. If the magnitude of the acceleration needs to remain constant and equal to $9g$, where g is the acceleration due to gravity, determine the radius of curvature of the turn.

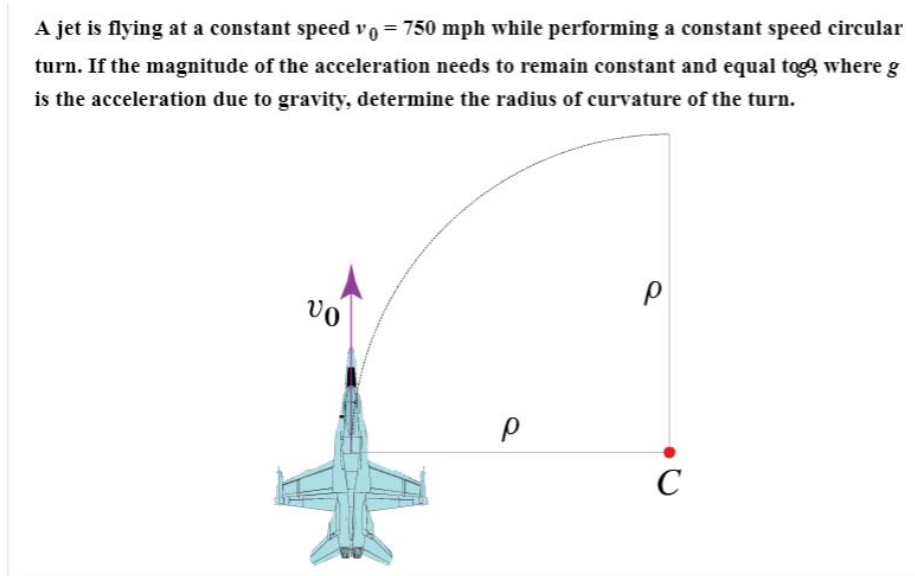

$$\bar{a} = \dot{V}\hat{u}_t + \frac{V^2}{\rho}\hat{u}_n$$

But $\dot{V} = 0$ since velocity is constant. Hence $|\bar{a}| = \frac{V^2}{\rho}$. Therefore

$$\begin{aligned} \frac{V^2}{\rho} &= 9g \\ \frac{\left(750\left(\frac{5280}{3600}\right)\right)^2}{9(32.2)} &= \rho \\ \rho &= 4175.3 \text{ ft} \end{aligned}$$

6.2.4 Problem 4

A race boat is traveling at a constant speed $v_0 = 85$ mph when it performs a turn with constant radius ρ to change its course by 90° as shown. The turn is performed while losing speed uniformly in time so that the boat's speed at the end of the turn is $v_f = 80$ mph. If the maximum allowed normal acceleration is equal to $3g$, where g is the acceleration due to gravity, determine the tightest radius of curvature possible and the time needed to complete the turn.

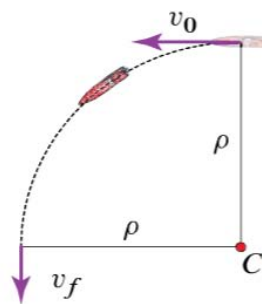

$$\begin{aligned} \rho_{\min} &= \boxed{} \text{ ft} \\ t_f &= \boxed{} \text{ s} \end{aligned}$$

$$\bar{a} = \dot{V}\hat{u}_t + \frac{V^2}{\rho}\hat{u}_n$$

Maximum normal acceleration is $\frac{V^2}{\rho}$. Hence it occurs when V is maximum, which is at start of turn. Then we want

$$\frac{V_{\max}^2}{\rho_{\min}} = 2g$$

$$\rho_{\min} = \frac{V_{\max}^2}{g} = \frac{\left(85\left(\frac{5280}{3600}\right)\right)^2}{2(32.2)} = 241.33 \text{ ft}$$

Now since

$$v_f^2 = v_o^2 + 2a_t s$$

Where a_t is tangential acceleration and s is distance travelled which is $\frac{1}{4}$ of circumference of circle or $\frac{1}{4}(2\pi\rho_{\min})$, therefore

$$a_t = \frac{v_f^2 - v_o^2}{2\left(\frac{1}{2}\pi\rho_{\min}\right)} = \frac{\left(80\left(\frac{5280}{3600}\right)\right)^2 - \left(85\left(\frac{5280}{3600}\right)\right)^2}{\pi(241.33)} = -2.341 \text{ ft/sec}^2$$

Therefore to find time of travel, since acceleration is constant

$$v_f = v_o + a_t t$$

$$t = \frac{v_f - v_o}{a_t} = \frac{80\left(\frac{5280}{3600}\right) - 85\left(\frac{5280}{3600}\right)}{-2.341} = 3.133 \text{ sec}$$

6.2.5 Problem 5

A radar station is tracking a plane flying at a constant altitude with a speed $v_0 = 560$ mph.

If, at a given instant $r = 6.9$ mi and $\theta = 31^\circ$, determine the corresponding values of \dot{r} , $\dot{\theta}$, \ddot{r} , $\ddot{\theta}$.

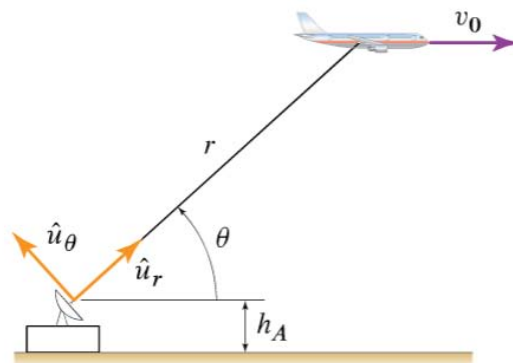

$$\begin{aligned} \dot{r} &= \boxed{} \text{ mph} \\ \dot{\theta} &= \boxed{} \text{ rad/h} \\ \ddot{r} &= \boxed{} \text{ mi/h}^2 \\ \ddot{\theta} &= \boxed{} \text{ rad/h}^2 \end{aligned}$$

Since velocity is horizontal, then

$$\bar{v} = v_0\hat{i}$$

But $\hat{i} = \cos\theta\hat{u}_r - \sin\theta\hat{u}_\theta$, hence

$$\begin{aligned} \bar{v} &= v_0 \cos\theta\hat{u}_r - v_0 \sin\theta\hat{u}_\theta \\ &= \dot{r}\hat{u}_r + r\dot{\theta}\hat{u}_\theta \end{aligned}$$

Therefore

$$\begin{aligned}\dot{r} &= v_0 \cos \theta \\ r\dot{\theta} &= -v_0 \sin \theta\end{aligned}$$

We are given that $v_0 = 560$ mph and $\theta = 31$, hence solving gives

$$\begin{aligned}\dot{r} &= 560 \cos \left(31 \frac{\pi}{180} \right) \\ (6.9) \dot{\theta} &= -(560) \sin \left(31 \frac{\pi}{180} \right)\end{aligned}$$

Or

$$\begin{aligned}\dot{r} &= 480.014 \text{ mph} \\ \dot{\theta} &= -41.8 \text{ rad/h}\end{aligned}$$

The acceleration vector is

$$\bar{a} = (\ddot{r} - r\dot{\theta}^2) \hat{u}_r + (r\ddot{\theta} + 2\dot{r}\dot{\theta}) \hat{u}_\theta$$

Since constant velocity, then acceleration is zero. This gives us two equations to solve for $\ddot{\theta}, \ddot{r}$

$$\begin{aligned}\ddot{r} - r\dot{\theta}^2 &= 0 \\ r\ddot{\theta} + 2\dot{r}\dot{\theta} &= 0\end{aligned}$$

Or

$$\begin{aligned}\ddot{r} - (6.9)(-41.8)^2 &= 0 \\ (6.9)\ddot{\theta} + 2(480.014)(-41.8) &= 0\end{aligned}$$

Solving gives

$$\begin{aligned}\ddot{r} &= 12054.23 \text{ mph} \\ \ddot{\theta} &= 5815.477 \text{ rad/h}^2\end{aligned}$$

6.2.6 Problem 6

During a given time interval, a radar station tracking an airplane records the readings

$$\dot{r}(t) = [448.1 \cos \theta(t) + 13.17 \sin \theta(t)] \text{ mph},$$

$$r(t)\dot{\theta}(t) = [13.17 \cos \theta(t) - 448.1 \sin \theta(t)] \text{ mph},$$

where t denotes time. Determine the speed of the plane. Furthermore, determine whether the plane being tracked is ascending or descending and the corresponding climbing rate (i.e., the rate of change of the plane's altitude) expressed in ft/s.

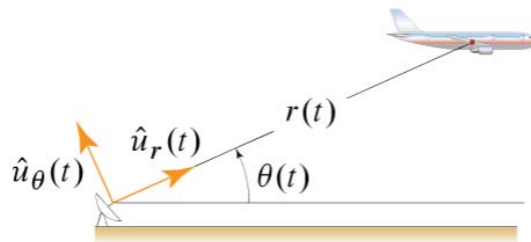

$v =$ mi/h

The airplane is (select) at a rate of ft/s.

$$\begin{aligned}\bar{v} &= \dot{r}\hat{u}_r + r\dot{\theta}\hat{u}_\theta \\ &= (448.1 \cos \theta + 13.17 \sin \theta) \hat{u}_r + (13.17 \cos \theta - 448.1 \sin \theta) \hat{u}_\theta\end{aligned}$$

Hence

$$\begin{aligned} |\bar{v}|^2 &= (448.1 \cos \theta + 13.17 \sin \theta)^2 + (13.17 \cos \theta - 448.1 \sin \theta)^2 \\ &= (448.1)^2 \cos^2 \theta + (13.17)^2 \sin^2 \theta + 2((448.1)(13.17) \cos \theta \sin \theta) \\ &\quad + (13.17)^2 \cos^2 \theta + (-448.1)^2 \sin^2 \theta - 2((448.1)(13.17) \cos \theta \sin \theta) \end{aligned}$$

Which simplifies to

$$\begin{aligned} |\bar{v}|^2 &= (448.1)^2 \cos^2 \theta + (13.17)^2 \sin^2 \theta + (13.17)^2 \cos^2 \theta + (-448.1)^2 \sin^2 \theta \\ &= (448.1)^2 (\cos^2 \theta + \sin^2 \theta) + (13.17)^2 (\cos^2 \theta + \sin^2 \theta) \\ &= (448.1)^2 + (13.17)^2 \\ &= 200967.1 \end{aligned}$$

Hence

$$|\bar{v}| = 448.294 \text{ mph}$$

Let y be vertical distance. Hence $y = r \sin \theta$ and

$$\begin{aligned} \dot{y} &= \dot{r} \sin \theta + r \dot{\theta} \cos \theta \\ &= (448.1 \cos \theta + 13.17 \sin \theta) \sin \theta + (13.17 \cos \theta - 448.1 \sin \theta) \cos \theta \\ &= 448.1 \cos \theta \sin \theta + 13.17 \sin^2 \theta + 13.17 \cos^2 \theta - 448.1 \sin \theta \cos \theta \\ &= 13.17 \text{ mph} \end{aligned}$$

Hence it is ascending. Convert to ft/sec

$$\begin{aligned} \dot{y} &= 13.17 \frac{5280 \text{ hr}}{\text{mile}} \frac{1}{3600} \\ &= 13.17 \frac{5280}{3600} \\ &= 19.316 \text{ ft/sec} \end{aligned}$$

6.3 HW 3

6.3.1 Problem 1

A remote control boat, capable of a maximum speed of 8 ft/s in still water, is made to cross a stream with a width $w = 37$ ft that is flowing with a speed $v_W = 7$ ft/s. If the boat starts from point O and keeps its orientation parallel to the cross-stream direction, find the location of point A at which the boat reaches the other bank while moving at its maximum speed. Furthermore, determine how long the crossing requires.

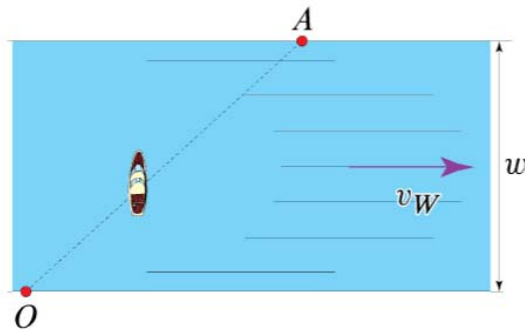

$$t = \boxed{} \text{ s}$$

$$x = \boxed{} \text{ ft}$$

The time to reach the top edge of the river is

$$t = \frac{37}{8} = 4.625 \text{ sec}$$

The distance travelled in horizontal direction is therefore

$$x = (7)(4.625) = 32.375 \text{ ft}$$

6.3.2 Problem 2

The object in the figure is called a *gun tackle*, and it used to be very common on sailboats to help in the operation of front-loaded guns. If the end A is pulled down at a speed of 1.5 m/s, determine the velocity of B . Neglect the fact that some portions of the rope are not vertically aligned.

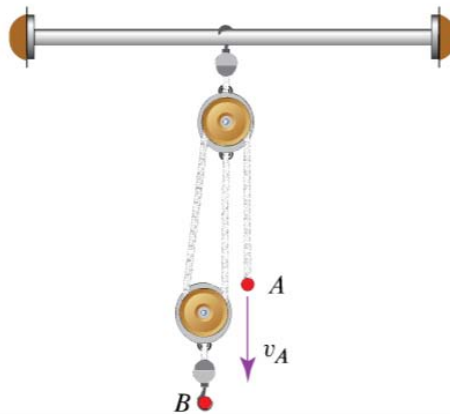

$$v_B = \boxed{} \text{ m/s}$$

Length of rope L is

$$L = 2x_B + x_A$$

Where x_B is distance from top to B and x_A is distance from top to A . Taking derivatives gives

$$0 = 2v_B + v_A$$

$$v_B = -\frac{v_A}{2} = -\frac{-1.5}{2} = 0.75 \text{ m/s}$$

6.3.3 Problem 3

The piston head at C is constrained to move along the y axis. Let the crank AB be rotating counterclockwise at a constant angular speed $\dot{\theta} = 1,950$ rpm, $R = 3.4$ in., and $L = 5.7$ in. Determine the velocity of C when $\theta = 40^\circ$.

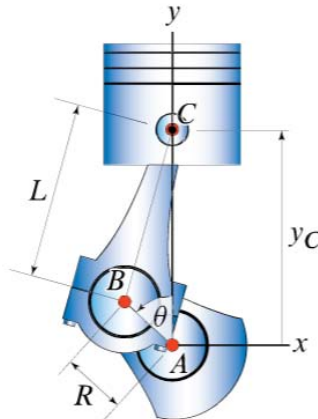

$\dot{y}_C =$ ft/s

$$\begin{aligned} \frac{d\theta}{dt} &= (1950) \left(\frac{2\pi}{\text{rotation}} \right) \left(\frac{\text{minute}}{60} \right) \\ &= (1950) \frac{2\pi}{60} \\ &= 204.2035 \text{ rad/sec} \end{aligned}$$

But

$$L^2 = R^2 + y_c^2 - 2(R)(y_c) \cos(\theta)$$

$$y_c^2 - 2Ry_c \cos(\theta) + (R^2 - L^2) = 0$$

Or

$$\begin{aligned} y_c &= \frac{-b}{2a} \pm \frac{\sqrt{b^2 - 4ac}}{2a} \\ &= R \cos \theta \pm \frac{1}{2} \sqrt{4R^2 \cos^2 \theta - 4(R^2 - L^2)} \\ &= R \cos \theta \pm \frac{1}{2} \sqrt{4R^2 \cos^2 \theta - 4R^2 + 4L^2} \\ &= R \cos \theta \pm \frac{1}{2} \sqrt{4R^2 (\cos^2 \theta - 1) + 4L^2} \\ &= R \cos \theta \pm \frac{1}{2} \sqrt{-4R^2 \sin^2 \theta + 4L^2} \\ &= R \cos \theta \pm \sqrt{L^2 - R^2 \sin^2 \theta} \end{aligned}$$

At $\theta = 0$, $y_c = R + L$, therefore we pick the plus sign

$$y_c = R \cos \theta + \sqrt{L^2 - R^2 \sin^2 \theta}$$

Taking derivative with time

$$\begin{aligned}\dot{y}_c &= -R\dot{\theta} \sin \theta + \frac{1}{2} \frac{1}{\sqrt{L^2 - R^2 \sin^2(\theta)}} (-2R^2 \sin \theta (\dot{\theta} \cos \theta)) \\ &= -R\dot{\theta} \sin \theta - \frac{R^2 \dot{\theta} \sin \theta \cos \theta}{\sqrt{L^2 - R^2 \sin^2(\theta)}}\end{aligned}$$

Plugging in values $R = \frac{3.4}{12}$ ft, $L = \frac{5.7}{12}$ ft and $\theta = 40^\circ$ and $\dot{\theta} = 204.2035$ gives

$$\begin{aligned}\dot{y}_c &= -\left(\frac{3.4}{12}\right)(204.2035) \sin\left(\frac{40}{180}\pi\right) - \frac{\left(\frac{3.4}{12}\right)^2 (204.2035) \sin\left(\frac{40}{180}\pi\right) \cos\left(\frac{40}{180}\pi\right)}{\sqrt{\left(\frac{5.7}{12}\right)^2 - \left(\frac{3.4}{12}\right)^2 \left(\sin\left(\frac{40}{180}\pi\right)\right)^2}} \\ &= -55.59 \text{ ft/sec}\end{aligned}$$

6.3.4 Problem 4

A horse is lifting a 550 lb crate by moving to the right at a constant speed $v_0 = 3.2$ ft/s. Observing that B is fixed and letting $h = 6.4$ ft and $\ell = 14.5$ ft, determine the tension in the rope when the horizontal distance d between B and point A on the horse is 9.5 ft.

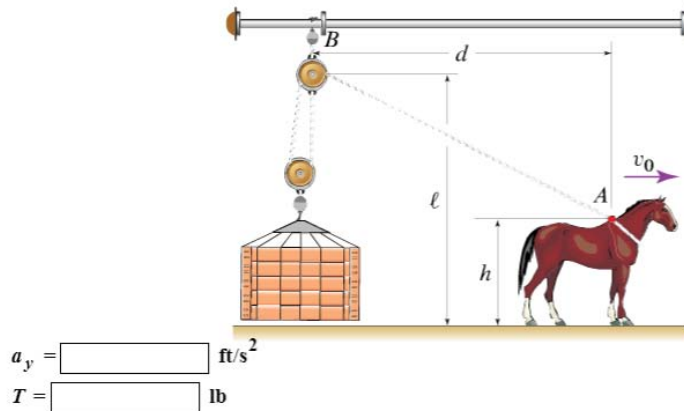

Resolving forces in vertical direction

$$mg - 2T = m\ddot{y} \quad (1)$$

To find y , since rope length is

$$L = 2y + \sqrt{x_A^2 + (l-h)^2}$$

Taking derivative gives

$$\begin{aligned}0 &= 2\dot{y} + \frac{x_A \dot{x}_A}{\sqrt{x_A^2 + (l-h)^2}} \\ \dot{y} &= \frac{-x_A \dot{x}_A}{\sqrt{x_A^2 + (l-h)^2}}\end{aligned}$$

Taking another derivative

$$\ddot{y} = \frac{-\dot{x}_A^2}{2\sqrt{x_A^2 + (l-h)^2}} + \frac{x_A^2 \dot{x}_A^2}{2(x_A^2 + (l-h)^2)^{\frac{3}{2}}}$$

But $\dot{x}_A = v_0 = 3.2$ ft/sec. Hence

$$\ddot{y} = \frac{-v_0^2}{2\sqrt{x_A^2 + (l-h)^2}} + \frac{x_A^2 v_0^2}{2(x_A^2 + (l-h)^2)^{\frac{3}{2}}}$$

When $l = 14.5, h = 6.4, x_A = 9.5$ then

$$\begin{aligned}\ddot{y} &= \frac{-(3.2)^2}{2\sqrt{9.5^2 + (14.5 - 6.4)^2}} + \frac{(9.5)^2 (3.2)^2}{2(9.5^2 + (14.5 - 6.4)^2)^{\frac{3}{2}}} \\ &= -0.17264 \text{ ft/sec}^2\end{aligned}$$

From (1) we solve for tension

$$\begin{aligned}T &= \frac{mg - m\ddot{y}}{2} \\ &= \frac{m(g - \ddot{y})}{2} \\ &= \frac{550(32.2 - (-0.17264))}{2} \\ &= 8902.476 \text{ lb force}\end{aligned}$$

Hence

$$\begin{aligned}T &= \frac{8902.476}{32.2} \\ &= 276.474 \text{ lb}\end{aligned}$$

6.3.5 Problem 5

Car bumpers are designed to limit the extent of damage to the car in the case of low-velocity collisions. Consider a 3,340 lb passenger car impacting a concrete barrier while traveling at a speed of 4.3 mph. Model the car as a particle, and consider two types of bumper: (1) a simple linear spring with constant k and (2) a linear spring of constant k in parallel with a shock absorbing unit generating a nearly constant force of 10 lb over 0.21 ft. If the bumper is of type 1, find the value of k necessary to stop the car in a distance of 0.21 ft.

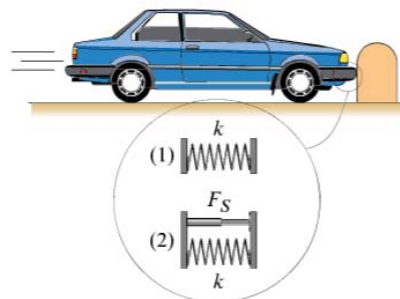

$$k = \boxed{} \times 10^4 \text{ lb/ft}$$

Resolving forces in the x direction gives equation of motion

$$\begin{aligned}m\ddot{x} + kx &= 0 \\ \ddot{x} &= -\frac{k}{m}x\end{aligned}$$

Let $\frac{d^2x}{dt^2} = \frac{dv}{dt} = \frac{dv}{dx} \frac{dx}{dt} = v \frac{dv}{dx}$ and the above becomes

$$v \frac{dv}{dx} = -\frac{k}{m}x$$

This is now separable

$$\int_{v_i}^{v_{stop}} v dv = -\int_0^{x_i} \frac{k}{m} x dx$$

But $v_{stop} = 0$ and the above becomes

$$v_i^2 = \frac{k}{m} x_i^2$$

For $v_i = 4.3$ mph and $x_i = 0.21$ ft, we solve for k from the above

$$\begin{aligned} k &= \frac{mv_i^2}{x_i^2} = \frac{\left(\frac{3340}{32.2}\right)\left(4.3\left(\frac{5280}{3600}\right)\right)^2}{(0.21)^2} \\ &= 93551.7 \text{ lb/ft} \\ &= 9.355 \times 10^{-4} \text{ lb/ft} \end{aligned}$$

Question, why had to divide by g in above to get correct answer? Problem said *lb* in statement?

6.3.6 Problem 6

A railcar with an overall mass of 74,000 kg traveling with a speed v_i is approaching a barrier equipped with a bumper consisting of a nonlinear spring whose force vs. compression law is given by $F_S = \beta x^3$, where $\beta = 650 \times 10^6 \text{ N/m}^3$ and x is the compression of the bumper. Treating the system as a particle, assuming that the contact between railcar and rails is frictionless, and letting $v_i = 3 \text{ km/h}$, determine the bumper compression necessary to bring the railcar to a stop.

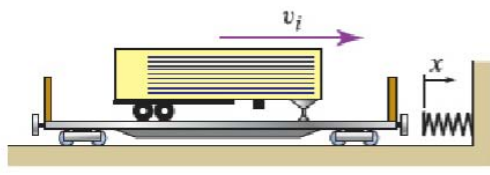

$x_{stop} = \boxed{} \text{ m}$

Resolving forces in the x direction gives equation of motion

$$\begin{aligned} m\ddot{x} + \beta x^3 &= 0 \\ \ddot{x} &= -\frac{\beta x^3}{m} \end{aligned}$$

Let $\frac{d^2x}{dt^2} = \frac{dv}{dt} = \frac{dv}{dx} \frac{dx}{dt} = v \frac{dv}{dx}$ and the above becomes

$$v \frac{dv}{dx} = -\frac{\beta x^3}{m}$$

This is now separable

$$\int_{v_i}^{v_{stop}} v dv = -\frac{\beta}{m} \int_0^{x_{stop}} x^3 dx$$

But $v_{stop} = 0$ and the above becomes

$$v_i^2 = \frac{1}{2} \frac{\beta}{m} x_{stop}^4$$

For $v_i = 3 \text{ km/h}$ and $\beta = 650 \times 10^6$ and $m = 75000 \text{ kg}$, we solve for x_{stop} from the above

$$\begin{aligned} x_{stop} &= \left(\frac{2mv_i^2}{\beta}\right)^{\frac{1}{4}} \\ &= \left(\frac{2(75000)\left(3\left(\frac{1000}{3600}\right)\right)^2}{650 \times 10^6}\right)^{\frac{1}{4}} \\ &= 0.11776 \text{ m} \end{aligned}$$

6.4 HW 4

6.4.1 Problem 1

A 970 kg aerobatics plane initiates the basic loop maneuver at the bottom of a loop with radius $\rho = 115$ m and a speed of 228 km/h. At this instant, determine the magnitude of the plane's acceleration, expressed in terms of g , the acceleration due to gravity, and the magnitude of the lift provided by the wings.

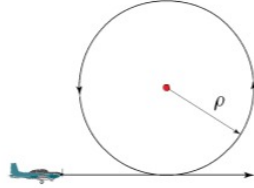

$$a = \boxed{} g$$

$$F_{\text{lift}} = \boxed{} \text{ N}$$

The velocity in meter per second is

$$\begin{aligned} v &= 228 \left(\frac{1000}{\text{km}} \right) \left(\frac{\text{h}}{3600} \right) \\ &= (228) \frac{1000}{3600} \\ &= 63.333 \text{ m/s} \end{aligned}$$

In normal direction, the acceleration is $a_n = \frac{v^2}{\rho} = \frac{(63.333)^2}{115} = 34.879 \text{ m/s}^2$ or in terms of g , it becomes $\frac{34.879}{9.81} = 3.555 g$.

Now, force balance in vertical direction gives

$$\begin{aligned} L - mg &= ma_n \\ L &= m(g + a_n) \\ &= 970(9.81 + 34.879) \\ &= 43348.33 \text{ N} \end{aligned}$$

6.4.2 Problem 2

A race car is traveling at a constant speed over a circular banked turn. Oil on the track has caused the static friction coefficient between the tires and the track to be $\mu_s = 0.2$. If the radius of the car's trajectory is $\rho = 324$ m and the bank angle is $\theta = 31^\circ$, determine the range of speeds within which the car must travel not to slide sideways.

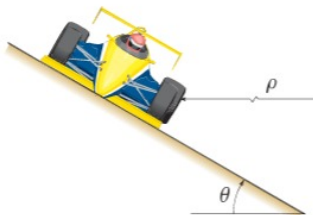

$$\boxed{} \text{ km/h} \leq v \leq \boxed{} \text{ km/h}$$

For maximum speed, friction acts downwards as car assumed to be just about to slide

upwards. Resolving forces in normal and tangential gives

$$\mu_s N \cos \theta + N \sin \theta = m \frac{v_{\max}^2}{\rho} \quad (1)$$

$$-mg + N \cos \theta - \mu_s N \sin \theta = 0 \quad (2)$$

From (2)

$$N = \frac{mg}{\cos \theta - \mu_s \sin \theta}$$

From (1)

$$\begin{aligned} v_{\max}^2 &= \frac{\rho}{m} (\mu_s N \cos \theta + N \sin \theta) \\ &= \frac{\rho}{m} \left(\mu_s \left(\frac{mg}{\cos \theta - \mu_s \sin \theta} \right) \cos \theta + \left(\frac{mg}{\cos \theta - \mu_s \sin \theta} \right) \sin \theta \right) \\ &= \rho \left(\mu_s \left(\frac{g}{\cos \theta - \mu_s \sin \theta} \right) \cos \theta + \left(\frac{g}{\cos \theta - \mu_s \sin \theta} \right) \sin \theta \right) \\ &= \rho g \left(\frac{\mu_s}{1 - \mu_s \tan \theta} + \frac{\tan \theta}{1 - \mu_s \tan \theta} \right) \\ &= \rho g \left(\frac{\mu_s + \tan \theta}{1 - \mu_s \tan \theta} \right) \\ &= 324 (9.81) \left(\frac{0.2 + \tan \left(31 \frac{\pi}{180} \right)}{1 - 0.2 \tan \left(31 \frac{\pi}{180} \right)} \right) \\ &= 2893.165 \text{ m/s} \end{aligned}$$

Hence

$$\begin{aligned} v_{\max} &= 53.788 \text{ m/s} \\ &= 53.788 (0.001) (3600) \\ &= 193.637 \text{ km/hr} \end{aligned}$$

For minimum speed, friction acts upwards as car assumed to be just about to slide downwards. Resolving forces in normal and tangential gives

$$-\mu_s N \cos \theta + N \sin \theta = m \frac{v_{\min}^2}{\rho} \quad (3)$$

$$-mg + N \cos \theta + \mu_s N \sin \theta = 0 \quad (4)$$

From (4)

$$N = \frac{mg}{\cos \theta + \mu_s \sin \theta}$$

From (3)

$$\begin{aligned} v_{\min}^2 &= \frac{\rho}{m} (-\mu_s N \cos \theta + N \sin \theta) \\ &= \frac{\rho}{m} \left(-\mu_s \left(\frac{mg}{\cos \theta + \mu_s \sin \theta} \right) \cos \theta + \left(\frac{mg}{\cos \theta + \mu_s \sin \theta} \right) \sin \theta \right) \\ &= \rho g \left(-\mu_s \left(\frac{1}{\cos \theta + \mu_s \sin \theta} \right) \cos \theta + \left(\frac{1}{\cos \theta + \mu_s \sin \theta} \right) \sin \theta \right) \\ &= \rho g \left(\frac{-\mu_s}{1 + \mu_s \tan \theta} + \frac{\tan \theta}{1 + \mu_s \tan \theta} \right) \\ &= \rho g \left(\frac{\tan \theta - \mu_s}{1 + \mu_s \tan \theta} \right) \\ &= 324 (9.81) \left(\frac{\tan \left(31 \frac{\pi}{180} \right) - 0.2}{1 + 0.2 \tan \left(31 \frac{\pi}{180} \right)} \right) \\ &= 1137.425 \text{ m/s} \end{aligned}$$

Hence

$$\begin{aligned} v_{\min} &= 33.726 \text{ m/s} \\ &= 33.726 (0.001) (3600) \\ &= 121.414 \text{ km/hr} \end{aligned}$$

Hence

$$121.414 \leq v \leq 193.637$$

6.4.3 Problem 3

The cutaway of the gun barrel shows a projectile moving through the barrel. If the projectile's exit speed is $v_s = 1,681 \text{ m/s}$ (relative to the barrel), the projectile's mass is 16.9 kg , the length of the barrel is $L = 4.2 \text{ m}$, the acceleration of the projectile down the gun barrel is constant, and θ is increasing at a constant rate of 0.18 rad/s , determine

- The acceleration of the projectile.
- The pressure force acting on the back of the projectile.
- The normal force on the gun barrel due to the projectile.

as the projectile leaves the gun, but while it is still in the barrel. Assume that the projectile exits the barrel when $\theta = 23^\circ$, and ignore the friction between the projectile and the barrel.

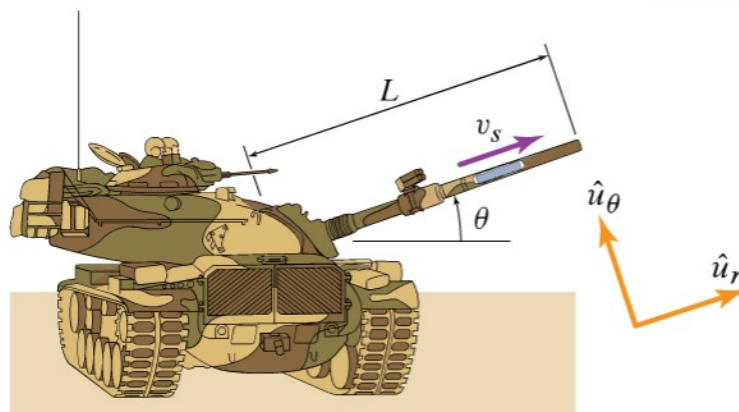

Part 1 out of 3

Part 1

(a) $\vec{a} = \boxed{336} \times 10^3 \hat{u}_r + \boxed{605} \hat{u}_\theta \text{ m/s}^2$

Part 2

(b) The pressure force is $\boxed{5.69} \times 10^6 \text{ N}$ in the r direction.

Part 3

(c) The normal force on the gun barrel due to the projectile is $\boxed{10.4} \times 10^3 \text{ N}$ in the positive θ direction.

6.4.3.1 part (1)

Since acceleration is constant along barrel, then using

$$v_f^2 = v_0^2 + 2\ddot{r}L$$

We will solve for \ddot{r} . Assuming $v_0 = 0$ then

$$1681^2 = 2\dot{r} \quad (4.2)$$

$$\dot{r} = \frac{1681^2}{2} \quad (4.2)$$

$$= 336400.1 \text{ m/s}^2$$

But

$$\bar{a} = (\ddot{r} - L\dot{\theta}^2)\hat{u}_r + (L\ddot{\theta} + 2\dot{r}\dot{\theta})\hat{u}_\theta$$

But $\ddot{\theta} = 0$, hence the above becomes

$$\begin{aligned} \bar{a} &= (336400.1 - (4.2)(0.18)^2)\hat{u}_r + (2(1681)(0.18))\hat{u}_\theta \\ &= 336400\hat{u}_r + 605.16\hat{u}_\theta \end{aligned}$$

6.4.3.2 part (2)

Free body diagram for bullet gives

$$P = ma_r + mg \sin \theta$$

but $a_r = 336400 \text{ m/s}^2$ and $m = 16.9 \text{ kg}$ and $\theta = 23^\circ$, hence

$$\begin{aligned} P &= (16.9)(336400) + (16.9)(9.81) \sin\left(23 \frac{\pi}{180}\right) \\ &= 5685225 \text{ N} \\ &= 5.685 \times 10^6 \text{ N} \end{aligned}$$

6.4.3.3 Part (3)

Free body diagram for bullet gives

$$\begin{aligned} N &= ma_\theta + mg \cos \theta \\ &= (16.9)(605.16) + (16.9)(9.81) \cos\left(23 \frac{\pi}{180}\right) \\ &= 10379.81 \text{ N} \\ &= 10.379 \times 10^3 \text{ N} \end{aligned}$$

6.4.4 Problem 4

A force F_0 of 438 lb is applied to block B . Letting the weights of A and B be 50 and 71 lb, respectively, and letting the static and kinetic friction coefficients between blocks A and B be $\mu_1 = 0.26$, and the static and kinetic friction coefficients between block B and the ground be $\mu_2 = 0.46$, determine the accelerations of both blocks.

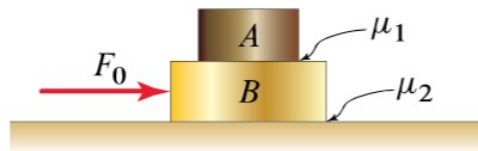

$$\vec{a}_A = (\text{[]})\hat{i} + (\text{[]})\hat{j} \text{ ft/s}^2 \begin{matrix} \uparrow j \\ \rightarrow i \end{matrix}$$

$$\vec{a}_B = (\text{[]})\hat{i} + (\text{[]})\hat{j} \text{ ft/s}^2 \begin{matrix} \uparrow j \\ \rightarrow i \end{matrix}$$

The free body diagram is

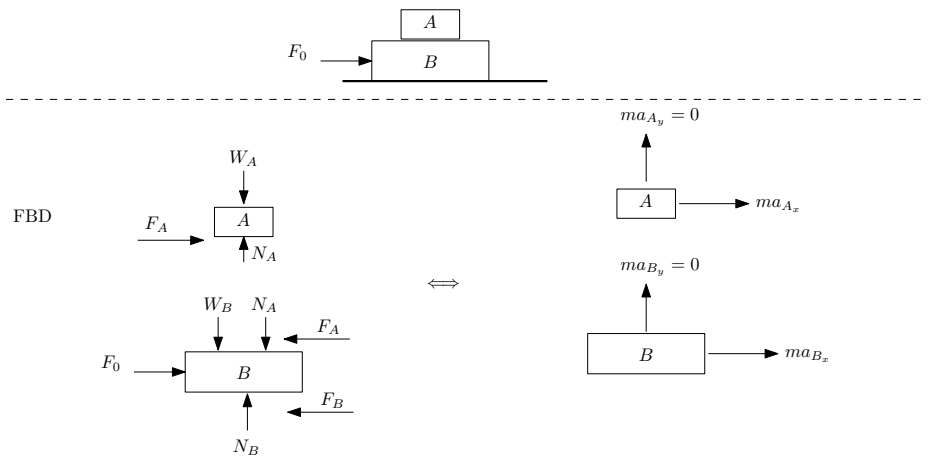

For A,

$$\begin{aligned}\sum F_x &= m_A a_{A_x} \\ F_A &= m_A a_{A_x}\end{aligned}\quad (2)$$

$$\begin{aligned}\sum F_y &= m_A a_{A_y} \\ N_A - W_A &= 0\end{aligned}\quad (3)$$

For B

$$\begin{aligned}\sum F_x &= m_B a_{B_x} \\ F_0 - F_A - F_B &= m_B a_{B_x}\end{aligned}\quad (4)$$

$$\begin{aligned}\sum F_y &= m_B a_{B_y} \\ N_B - W_B - N_A &= 0\end{aligned}\quad (5)$$

Hence (3) becomes

$$\begin{aligned}N_A &= W_A \\ &= m_A g\end{aligned}\quad (6A)$$

And (5) becomes

$$\begin{aligned}N_B &= W_B + N_A \\ &= m_B g + m_A g \\ &= (m_B + m_A) g\end{aligned}\quad (6B)$$

But $F_A = N_A \mu_1$ then (2) becomes

$$N_A \mu_1 = m_A a_{A_x}$$

But from (6) the above reduces to (since $N_A = m_A g$)

$$m_A g \mu_1 = m_A a_{A_x}$$

Hence

$$\begin{aligned}a_{A_x} &= g \mu_1 \\ &= (32.2)(0.26) \\ &= 8.372 \text{ ft/s}^2\end{aligned}$$

Similarly $F_B = N_B \mu_2$ hence (4) becomes

$$F_0 - N_A \mu_1 - N_B \mu_2 = m_B a_{B_x}$$

But $N_B = (m_A + m_B)g$, then above becomes

$$\begin{aligned}F_0 - m_A g \mu_1 - (m_A + m_B) g \mu_2 &= m_B a_{B_x} \\ a_{B_x} &= \frac{F_0 - m_A g \mu_1 - (m_A + m_B) g \mu_2}{m_B} \\ a_{B_x} &= \frac{438 - (50)(0.26) - (50 + 71)(0.46)}{\frac{71}{32.2}} \\ &= 167.504 \text{ ft/sec}^2\end{aligned}$$

6.4.5 Problem 5

Blocks A and B are connected by a pulley system. The coefficient of kinetic friction between the block A and the incline is $\mu_k = 0.3$ and static friction is insufficient to prevent slipping. The mass of A is $m_A = 7$ kg, the mass of B is $m_B = 20$ kg, and the angle between the incline and the horizontal is $\theta = 22^\circ$. Determine the acceleration of A , the acceleration of B , and the tension in the rope after the system is released.

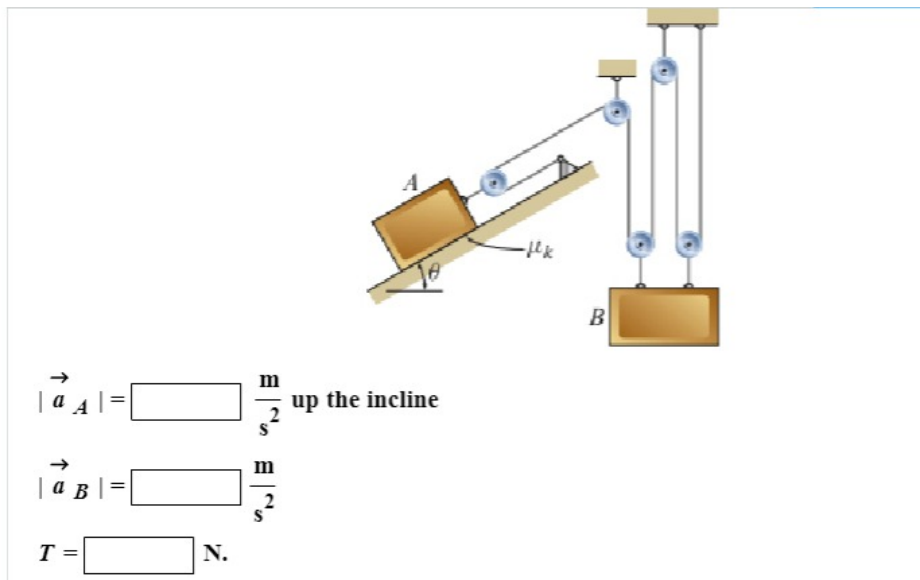

Free body diagram for block B results in

$$2g - \frac{8T}{m_B} = a_A$$

Free body diagram for block A results in

$$-m_A g \sin \theta - \mu m_A g \cos \theta + 2T = m_A a_A$$

In addition, since rope length is fixed, we find that $a_A = 2a_B$. The above are 3 equations in 3 unknowns T, a_A, a_B . Solving gives

$$a_A = 4.439 \text{ m/s}^2$$

$$a_B = 2.2197 \text{ m/s}^2$$

$$T = 37.95 \text{ N}$$

6.4.6 Problem 6

Two blocks A and B weighing 116 and 223 lb, respectively, are released from rest as shown. At the moment of release the spring is unstretched. In solving these problems, model A and B as particles, neglect air resistance, and assume that the cord is inextensible. *Hint:* If B hits the ground, then its maximum displacement is equal to the distance between the initial position of B and the ground. Determine the maximum displacement and the maximum speed of block B if $\alpha = 19^\circ$, the contact between A and the incline is frictionless, and the spring constant is $k = 28$ lb/ft.

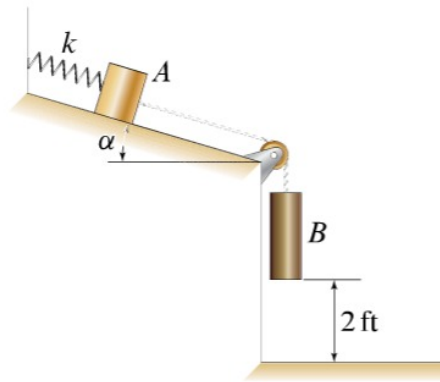

The maximum displacement of block B is ft and the maximum speed is ft/s.

maximum displacement is 2 ft. Maximum speed is 9.404 ft/sec.

6.5 HW 5

6.5.1 Problem 1

A 70 kg skydiver is falling at a speed of 241 km/h when the parachute is deployed, allowing the skydiver to land at a speed of 4 m/s. Modeling the skydiver as a particle, determine the total work done on the skydiver from the moment of parachute deployment until landing.

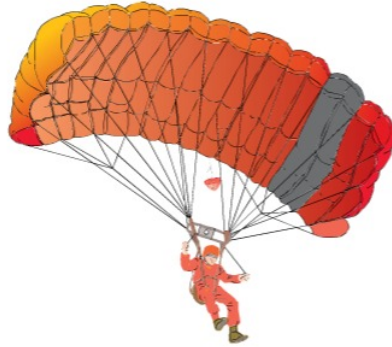

$U_{1-2} =$ kJ

Landing speed is $v_2 = 4 \text{ m/sec}$.

$$\begin{aligned}
 U_{12} &= T_2 - T_1 \\
 &= \frac{1}{2}mv_2^2 - \frac{1}{2}mv_1^2 \\
 &= \frac{1}{2}m \left(4^2 - \left(241 \frac{1000}{3600} \frac{\text{hr}}{\text{km}} \right)^2 \right) \\
 &= \frac{1}{2}70 \left((4)^2 - \left(241 \left(\frac{1000}{3600} \right) \right)^2 \right) \\
 &= -156294.6
 \end{aligned}$$

Hence work on person is -156.295 kJ

6.5.2 Problem 2

The crate A of weight $W = 32 \text{ lb}$ is being pulled to the right by the winch at B . The crate starts at $x = 0$ and is pulled a total distance of 15 ft over the rough surface for which the coefficient of kinetic friction is $\mu_k = 0.4$. The force P in the cable due to the winch varies according to the plot, where P is in lb, b is in $\text{lb}/\sqrt{\text{ft}}$, and x is in ft. The coefficient of static friction is insufficient to prevent slipping. Using the work-energy principle, determine the speed of the block when $b = 12 \text{ lb}/\sqrt{\text{ft}}$ and $x = 15 \text{ ft}$.

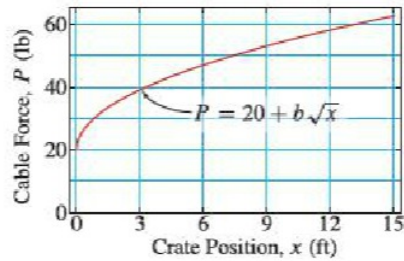
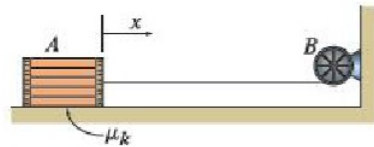

ft/s

Force in the x direction is

$$\begin{aligned} F &= F_p - F_{friction} \\ &= (20 + 12x) - \mu_k N \\ &= (20 + 12x) - (0.4)(32) \end{aligned}$$

Hence

$$\begin{aligned} U_{12} &= T_2 - T_1 \\ \int_0^{15} \vec{F} \cdot d\vec{r} &= \frac{1}{2}mv_2^2 - \frac{1}{2}mv_1^2 \\ \int_0^{15} \left((20 + 12x^{\frac{1}{2}}) - (0.4)(32) \right) dx &= \frac{1}{2} \frac{32}{32.2} v_2^2 \end{aligned}$$

Since $v_1 = 0$ then above becomes

$$\begin{aligned} \int_0^{15} \left((20 + 12x^{\frac{1}{2}}) - (0.4)(32) \right) dx &= \frac{1}{2} \left(\frac{32}{32.2} \right) v_2^2 \\ \int_0^{15} 12x^{\frac{1}{2}} + 7.2 dx &= 0.49689v_2^2 \\ \left(\frac{(12)(2)}{3} x^{\frac{3}{2}} + 7.2x \right) \Big|_0^{15} &= 0.49689v_2^2 \\ \frac{(12)(2)}{3} (15)^{\frac{3}{2}} + 7.2(15) &= 0.49689v_2^2 \\ 572.758 &= 0.49689v_2^2 \\ v_2^2 &= \frac{572.758}{0.49689} \\ &= 1152.686 \end{aligned}$$

Hence

$$\begin{aligned} v_2 &= \sqrt{1152.686} \\ &= 33.951 \text{ ft/sec} \end{aligned}$$

6.5.3 Problem 3

Car bumpers are designed to limit the extent of damage to the car in the case of low-velocity collisions. Consider a 1,324 kg passenger car impacting a concrete barrier while traveling at a speed of 5.5 km/h. Model the car as a particle and consider two bumper models: (1) a simple linear spring with constant k and (2) a linear spring of constant k in parallel with a shock absorbing unit generating a nearly constant force $F_S = 2,010$ N over 10 cm. If the bumper is of type (1) and if $k = 9.4 \times 10^4$ N/m, find the spring compression (distance) necessary to stop the car.

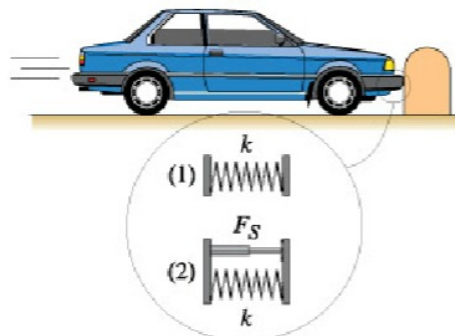

The spring compression necessary to stop the car is m.

Since all forces we can use conservation of energy $T_1 + V_1 = T_2 + V_2$ Where $V_1 = 0$ since spring is not compressed yet and $T_2 = 0$ since the car would be stopped by then. Hence

$$\begin{aligned}\frac{1}{2}mv_2^2 &= \frac{1}{2}k\Delta^2 \\ \Delta^2 &= \frac{mv_2^2}{k} \\ &= \frac{(1324) \left(5.5 \left(\frac{1000}{\text{km}}\right) \left(\frac{\text{hr}}{3600}\right)\right)^2}{9.4 \times 10^4} \\ &= \frac{(1324) \left(5.5 \left(\frac{1000}{3600}\right)\right)^2}{9.4 \times 10^4} \\ \Delta^2 &= 0.033\end{aligned}$$

Hence

$$\Delta = 0.182 \text{ meter}$$

We could also have solved this using work-energy. Force on car is $-kx$, hence $U_{12} = \int_0^x \vec{F} \cdot d\vec{r}$ and therefore

$$\begin{aligned}\int_0^x \vec{F} \cdot d\vec{r} &= \frac{1}{2}mv_2^2 - \frac{1}{2}mv_1^2 \\ \int_0^x -kx dx &= -\frac{1}{2}mv_1^2 \\ \frac{1}{2}k(x^2)_0^x &= \frac{1}{2}1324 \left(5.5 \left(\frac{1000}{3600}\right)\right)^2 \\ 9.4 \times 10^4 x^2 &= 1324 \left(5.5 \left(\frac{1000}{3600}\right)\right)^2 \\ x^2 &= \frac{1324 \left(5.5 \left(\frac{1000}{3600}\right)\right)^2}{9.4 \times 10^4} \\ x &= 0.182 \text{ meter}\end{aligned}$$

6.5.4 Problem 4

A classic car is driving down an incline at 58 km/h when its brakes are applied. Treating the car as a particle, neglecting all forces except gravity and friction, and assuming that the tires slip, determine the coefficient of kinetic friction if the car comes to a stop in 51 m and $\theta = 21^\circ$.

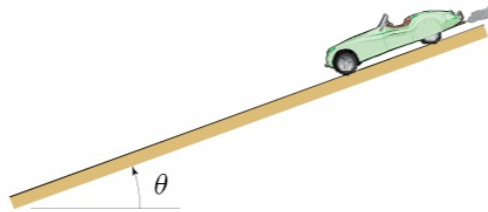

$$\mu_k = \boxed{}$$

Distance is $L = 51$ meter (not clear in problem image).

Taking zero PE at horizontal datum when car comes to a stop at the bottom of hill, then using

$$T_1 + V_1 + U_{12} = T_2 + V_2$$

Where T_1 is KE in state 1, when the car just hit the brakes, and V_1 is its gravitational PE and U_{12} is work by non-conservative forces, which is friction here. $T_2 = 0$ since car stops

in state 2 and V_2 is PE in state 2 which is zero. Hence we have

$$\begin{aligned}\frac{1}{2}mv_1^2 + mgL \sin \theta + \int_0^L -\mu N dx &= 0 \\ \frac{1}{2}mv_1^2 + mgL \sin \theta - \int_0^L \mu (mg \cos \theta) dx &= 0 \\ \frac{1}{2}mv_1^2 + mgL \sin \theta - L\mu mg \cos \theta &= 0 \\ \mu &= \frac{\frac{1}{2}v_1^2 + gL \sin \theta}{Lg \cos \theta}\end{aligned}$$

Hence

$$\begin{aligned}\mu &= \frac{\frac{1}{2} \left(58 \left(\frac{1000}{3600} \right) \right)^2 + 9.81 (51) \sin \left(21 \left(\frac{\pi}{180} \right) \right)}{(51) (9.81) \cos \left(21 \left(\frac{\pi}{180} \right) \right)} \\ &= \frac{129.7840 + 179.2951}{467.0796} \\ &= 0.662\end{aligned}$$

6.5.5 Problem 5

A pendulum with mass $m = 1.3$ kg and length $L = 1.86$ m is released from rest at an angle θ_i . Once the pendulum has swung to the vertical position (i.e., $\theta = 0$), its cord runs into a small fixed obstacle. In solving this problem, neglect the size of the obstacle, model the pendulum's bob as a particle, model the pendulum's cord as massless and inextensible, and let gravity and the tension in the cord be the only relevant forces. What is the maximum height, measured from its lowest point, reached by the pendulum if $\theta_i = 16^\circ$?

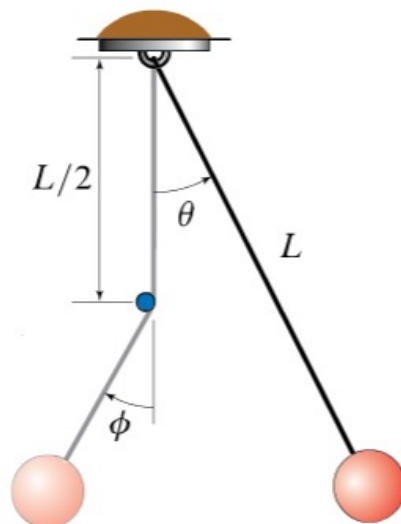

$$h_{\max} = \boxed{} \text{ m}$$

$$T_1 + V_1 = T_2 + V_2$$

Where state 1 is initial state, and state 2 is when bob at bottom. Datum is taken when bob

at bottom. Hence

$$0 + mg(L - L \cos \theta) = \frac{1}{2}mv_2^2 + 0$$

$$Lmg(1 - \cos \theta) = \frac{1}{2}mv_2^2$$

Now let state 3 be when bob is up again on the other side. Hence we have

$$T_2 + V_2 = T_3 + V_3$$

But $T_3 = 0$ and $V_3 = mgh_{\max}$, therefore

$$\frac{1}{2}mv_2^2 = mgh_{\max}$$

Or, since $\frac{1}{2}mv_2^2 = Lmg(1 - \cos \theta)$, then the above becomes

$$h_{\max} = L(1 - \cos \theta_i)$$

$$= 1.86 \left(1 - \cos \left(16 \left(\frac{\pi}{180} \right) \right) \right)$$

$$= 0.0721 \text{ m}$$

6.5.6 Problem 6

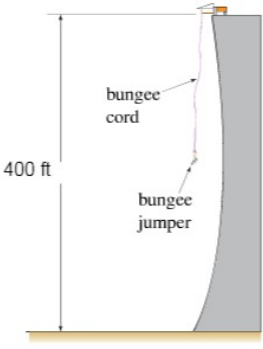

The diagram shows a bungee jumper hanging from a platform. A vertical dimension line on the left indicates a height of 400 ft from the platform to the jumper. Labels 'bungee cord' and 'bungee jumper' are present. The cord is shown as a curved line, indicating it is stretched.

While the stiffness of an elastic cord can be nearly constant (i.e., the force versus displacement curve is a straight line) over a large range of stretch, as a bungee cord is stretched, it softens; that is, the cord tends to get less stiff as it gets longer. Assuming a softening force–displacement relation of the form $k\delta - \beta\delta^3$, where $k = 2.60 \text{ lb/ft}$ and $\beta = 0.000014 \text{ lb/ft}^3$ and where δ (measured in ft) is the displacement of the cord from its unstretched length, and considering a bungee cord whose unstretched length is 150 ft,

Part 1 out of 3

(a) the expression of the cord's potential energy as a function of δ ;

$$V = \frac{\text{(select)} \text{ (select)}^2}{\text{ }} - \frac{\text{(select)} \text{ (select)}^4}{\text{ }}$$

6.5.6.1 Part (a)

$$V = \int^x k\delta - \beta\delta^3 d\delta$$

$$= \frac{kx^2}{2} - \frac{\beta x^4}{4}$$

6.5.6.2 Part (b)

Let datum be at top. Hence

$$\begin{aligned}
 T_1 + V_{1,gravity} + V_{1,rope} &= T_2 + V_{2,gravity} + V_{2,rope} \\
 0 + 0 + 0 &= \frac{1}{2}mv_2^2 - mgh + \left(\frac{k\delta^2}{2} - \frac{\beta\delta^4}{4}\right) \\
 v &= \sqrt{2gh - \frac{2}{m}\left(\frac{k\delta^2}{2} - \frac{\beta\delta^4}{4}\right)} \\
 &= \sqrt{\frac{\beta\delta^4 - 2k\delta^2 + 4mgh}{2m}} \\
 &= \sqrt{\frac{(0.000014)(150)^4 - 2(2.6)(150)^2 + 4(170)(150)}{2\left(\frac{170}{32.2}\right)}} \\
 &= \sqrt{-749.3603} \\
 &= \sqrt{\frac{(0.000013)(250)^4 - 2(2.58)(250)^2 + 4(170)(250)}{2\left(\frac{170}{32.2}\right)}}
 \end{aligned}$$

But $\delta = h - 150 = 400 - 150 = 250$, hence

$$\begin{aligned}
 v &= \sqrt{\frac{(0.000014)(250)^4 - 2(2.6)(250)^2 + 4(170)(400)}{2\left(\frac{170}{32.2}\right)}} \\
 &= 12.64184 \text{ ft/sec}
 \end{aligned}$$

6.5.6.3 Part (c)

$$\delta = \sqrt{\frac{k}{3\beta}} = \sqrt{\frac{2.6}{3(0.000014)}} = 248.8067$$

Hence

$$\begin{aligned}
 a &= \left|g\left(1 - \frac{k\delta - \beta\delta^3}{W}\right)\right| \\
 &= \left|32.2\left(1 - \frac{(2.6)(250) - (0.000014)(250)^3}{170}\right)\right| \\
 &= 49.48382 \text{ ft/s}^2 \\
 &= \frac{49.48382}{32.2} \\
 &= 1.537 \text{ g}
 \end{aligned}$$

6.6 HW 6

6.6.1 Problem 1

A 741 lb floating platform is at rest when a 210 lb crate is thrown onto it with a horizontal speed $v_0 = 15$ ft/s. Once the crate stops sliding relative to the platform, the platform and the crate move with a speed $v = 2.652$ ft/s. Neglecting the vertical motion of the system as well as any resistance due to the relative motion of the platform with respect to the water, determine the distance that the crate slides relative to the platform if the coefficient of kinetic friction between the platform and the crate is $\mu_k = 0.28$.

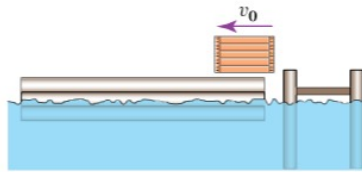

$d =$ ft

Let state 1 be when the crate is thrown at the platform. Let the crate be body A and the platform be body B . We will use work-energy to solve this.

$$T_1 + V_1 + U_{12}^{internal} + U_{12}^{external} = T_2 + V_2$$

Where $U_{12}^{internal}$ is work done due to internal forces between the two bodies, which is the friction. We will use notation v_{A_1} to mean velocity of A in state 1 and v_{A_2} to mean velocity of A in state 2 and the same for body B . Therefore the above equation becomes

$$\frac{1}{2}m_A v_{A_1}^2 + \frac{1}{2}m_B v_{B_1}^2 - \int_0^d \mu_k m_{AB} g dx = \frac{1}{2}m_A v_{A_2}^2 + \frac{1}{2}m_B v_{B_2}^2$$

Notice that $V_1 = V_2$ and hence they cancel. Also since in state 2 both body A and B move with same speed v , and also $v_{B_1} = 0$, then the above simplifies to

$$\frac{1}{2}m_A v_{A_1}^2 - \mu_k m_{AB} g d = \frac{1}{2}(m_A + m_B) v^2$$

We now solve for d , the distance that body A (the crate) slides. The above is one equation with one unknown.

$$\begin{aligned} d &= \frac{\frac{1}{2}m_A v_{A_1}^2 - \frac{1}{2}(m_A + m_B) v^2}{\mu_k m_{AB} g} \\ &= \frac{1}{2} \frac{(210)(15)^2 - (210 + 741)(2.652)^2}{(0.28)(210)(32.2)} \\ &= 10.712 \text{ ft} \end{aligned}$$

6.6.2 Problem 2

Blocks A and B are released from rest when the spring is unstretched. Block A has a mass $m_A = 4$ kg, and the linear spring has stiffness $k = 9$ N/m. If all sources of friction are negligible, determine the mass of block B such that B has a speed $v_B = 1.3$ m/s after moving 1.5 m downward, assuming that A never leaves the horizontal surface shown and the cord connecting A and B is inextensible.

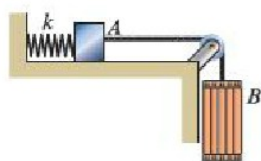

$m_B =$ kg.

Let state 1 be just before release and state 2 after it moves by 1.5 meter

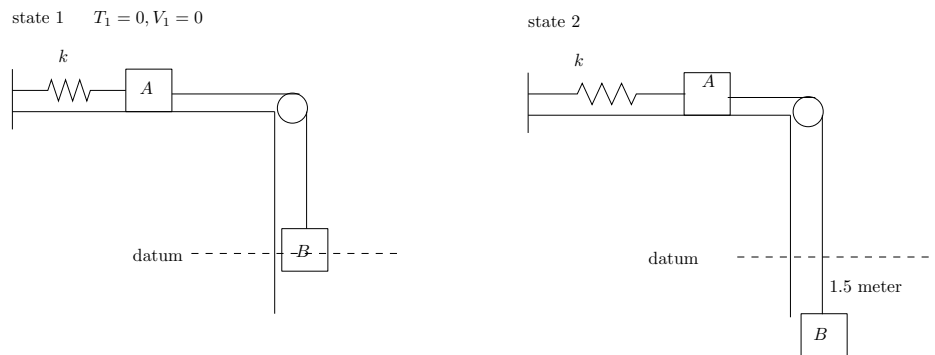

Therefore

$$T_1 + V_1 + U_{12}^{internal} + U_{12}^{external} = T_2 + V_2$$

$T_1 = 0, V_1 = 0$ and $U_{12} = 0$ since there is no friction and no external force. $T_2 = \frac{1}{2}(m_A + m_B)v^2$ since both bodies will have same speed. V_2 comes from spring and gravity. The distance $h = 1.5$ meter. Therefore $V_2 = \frac{1}{2}kh^2 - m_Bgh$ since spring extend by same amount m_B and m_A moves. The above becomes

$$0 = \frac{1}{2}(m_A + m_B)v^2 + \frac{1}{2}kh^2 - m_Bgh$$

Where v above is 1.3 since both bodies move with same speed. We want to solve for m_B the only unknown in this equation

$$\begin{aligned} 0 &= \frac{1}{2}m_A v^2 + \frac{1}{2}m_B v^2 + \frac{1}{2}kh^2 - m_Bgh \\ &= m_B \left(\frac{1}{2}v^2 - gh \right) + \frac{1}{2}m_A v^2 + \frac{1}{2}kh^2 \\ m_B &= \frac{m_A v^2 + kh^2}{2gh - v^2} \end{aligned}$$

Plug-in numerical values gives

$$\begin{aligned} m_B &= \frac{(4)(1.3)^2 + (9)(1.5)^2}{2(9.81)(1.5) - (1.3)^2} \\ &= 0.974 \text{ kg} \end{aligned}$$

6.6.3 Problem 3

Consider the simple catapult shown in the figure with an 814 lb counterweight A and a 129 lb projectile B . If the system is released from rest as shown, determine the speed of the projectile after the arm rotates (counterclockwise) through an angle of 110° . Model A and B as particles, neglect the mass of the catapult's arm, and assume that friction is negligible. The catapult's frame is fixed with respect to the ground, and the projectile does not separate from the arm during the motion considered.

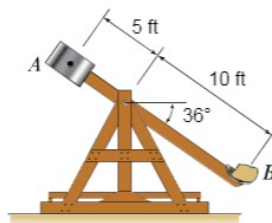

$v = \boxed{} \text{ ft/s}$

Let state 1 be just before release and state 2 after it rotation.

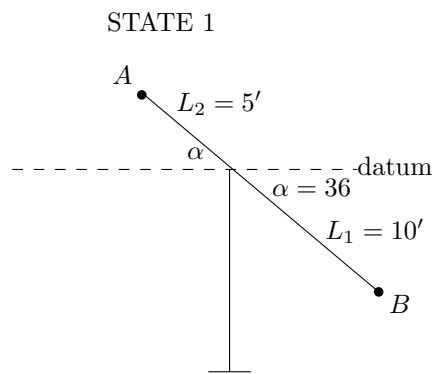

$$T_1 = 0$$

$$V_1 = -m_B g L_1 \sin \alpha + m_A g L_2 \sin \alpha$$

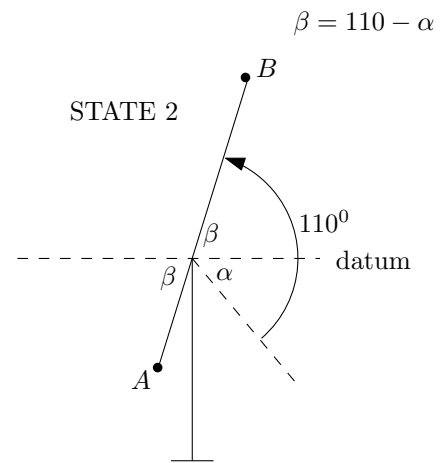

$$T_2 = \frac{1}{2} m_B (L_1 \omega)^2 + \frac{1}{2} m_A (L_2 \omega)^2$$

$$V_2 = m_B g L_1 \sin \beta - m_A g L_2 \sin \beta$$

$$T_1 + V_1 + U_{12}^{internal} + U_{12}^{external} = T_2 + V_2$$

But $U_{12} = 0$ since there is no friction and no external forces. Now $T_1 = 0$ since at rest. And

$$V_1 = -m_B g L_1 \sin \alpha + m_A g L_2 \sin \alpha$$

Where $\alpha = 36^\circ$. In state 2

$$T_2 = \frac{1}{2} m_B (L_1 \omega)^2 + \frac{1}{2} m_A (L_2 \omega)^2$$

Where ω is the angular velocity, which we do not know, but will solve for. And

$$V_2 = m_B g L_1 \sin \beta - m_A g L_2 \sin \beta$$

Therefore (1) becomes

$$\begin{aligned} -m_B g L_1 \sin \alpha + m_A g L_2 \sin \alpha &= \frac{1}{2} m_B (L_1 \omega)^2 + \frac{1}{2} m_A (L_2 \omega)^2 + m_B g L_1 \sin \beta - m_A g L_2 \sin \beta \\ -m_B g L_1 \sin \alpha + m_A g L_2 \sin \alpha - m_B g L_1 \sin \beta + m_A g L_2 \sin \beta &= \omega^2 \left(\frac{1}{2} m_B L_1^2 + \frac{1}{2} m_A L_2^2 \right) \\ \omega^2 &= \frac{m_A g L_2 (\sin \alpha + \sin \beta) - m_B g L_1 (\sin \alpha + \sin \beta)}{\frac{1}{2} m_B L_1^2 + \frac{1}{2} m_A L_2^2} \\ \omega &= \sqrt{\frac{2 (m_A g L_2 - m_B g L_1) (\sin \alpha + \sin \beta)}{m_B L_1^2 + m_A L_2^2}} \end{aligned}$$

Now we solve for ω and use it to find speed of B from $v_B = L_1 \omega$. Since $m_A = 814, m_B = 129, L_1 = 10, L_2 = 5, \alpha = 36, \beta = 110 - 36 = 74^\circ$ then

$$\begin{aligned} \omega &= \sqrt{2 \frac{((814)(32.2)(5) - (129)(32.2)(10)) \left(\sin \left(36 \left(\frac{\pi}{180} \right) \right) + \sin \left(74 \left(\frac{\pi}{180} \right) \right) \right)}{(129)10^2 + (814)5^2}} \\ &= 2.888 \text{ rad/sec} \end{aligned}$$

Hence

$$\begin{aligned} v_B &= L_1 \omega \\ &= 10(2.888) \\ &= 28.88 \text{ ft/sec} \end{aligned}$$

6.6.4 Problem 4

A cyclist is riding with a speed $v = 21$ mph over an inclined road with $\theta = 13^\circ$. Neglecting aerodynamic drag, if the cyclist were to keep his output power constant, what speed would he attain if θ were equal to 20° ?

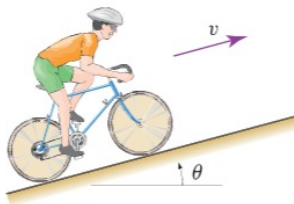

mph

Power P is

$$P = Fv$$

Where F is force generated by cyclist. From force balance we see that $F = mg \sin \theta$. Hence for constant power, we want

$$(mg \sin 13^\circ) v_1 = (mg \sin 20^\circ) v_2$$

Solving for v_2

$$\begin{aligned} v_2 &= \frac{(mg \sin 13^\circ) v_1}{(mg \sin 20^\circ)} \\ &= \frac{\sin\left(13\left(\frac{\pi}{180}\right)\right)}{\sin\left(20\left(\frac{\pi}{180}\right)\right)} 21 \\ &= 13.812 \text{ mph} \end{aligned}$$

6.6.5 Problem 5

The motor B is used to raise and lower the crate C via a pulley system. At the instant shown, the cable is being retracted by the motor with the constant speed $v_c = 4.5$ ft/s. The weight of the crate is $W_C = 460$ lb. If the power meter A shows a power input to the motor of 1.37 hp, determine the overall efficiency of the system.

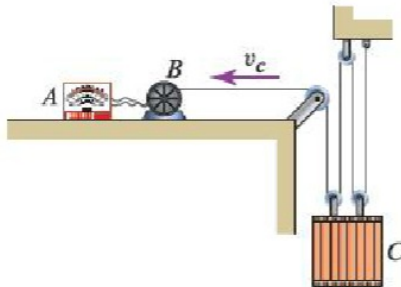

$\varepsilon =$

$$\varepsilon = \frac{P_{out}}{P_{in}}$$

Where ε is the efficiency and P_{out} is power out and P_{in} is power in. But $P_{out} = Fv_c$. So we just need to find force in the cable that the motor is pulling with. This force is $\frac{W}{4}$, since there are 4 cables and hence the weight is distributed over them, and then the tension in the one cable attached to the motor is $\frac{W}{4}$. Now we have all the information to find ε

$$\begin{aligned} P_{out} &= (4.5) \left(\frac{460}{4} \right) \\ &= 517.5 \text{ lb-ft/sec} \end{aligned}$$

But $hp = 550$ lb-ft/sec, therefore in hp the above is $\frac{517.5}{550} = 0.941$, hence

$$\varepsilon = \frac{0.941}{1.37} = 0.687$$

6.6.6 Problem 6

Assuming that the motor shown has an efficiency $\varepsilon = 0.78$, determine the power to be supplied to the motor if it is to pull $\mathbf{216\ lb}$ crate up the incline with a constant speed $v = 6.6\ \text{ft/s}$. Assume that the kinetic friction coefficient between the slide and the crate is $\mu_k = 0.24$ and that $\theta = 28^\circ$.

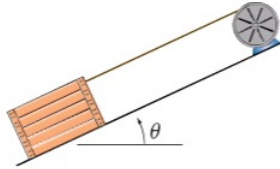

The power supplied to the motor is hp.

$$\varepsilon = \frac{P_{out}}{P_{in}}$$

Mass of crate is $\frac{216}{32.2}$ slug. (note, number given 216 is *weight*) These problem should make it more clear if *lb* given is meant to be weight or mass.

We need to find P_{in} . We are given ε . We now calculate P_{out} and then will be able to find P_{in} . But $P_{out} = Fv$, where F is force given by motor to pull the crate. From free body diagram, we see that this force is $F = \mu mg \cos \theta + mg \sin \theta$. Hence

$$\begin{aligned} P_{out} &= (\mu mg \cos \theta + mg \sin \theta) v \\ &= mg (\mu \cos \theta + \sin \theta) v \\ &= \left(\frac{216}{32.2} \right) (32.2) \left(0.24 \cos \left(28 \left(\frac{\pi}{180} \right) \right) + \sin \left(28 \left(\frac{\pi}{180} \right) \right) \right) (6.6) \\ &= 971.374\ \text{lb-ft/sec} \\ &= \frac{971.374}{550} = 1.766\ \text{hp} \end{aligned}$$

Hence

$$\begin{aligned} P_{in} &= \frac{P_{out}}{\varepsilon} \\ &= \frac{1.766}{0.78} \\ &= 2.264\ \text{hp} \end{aligned}$$

6.7 HW 7

6.7.1 Problem 1

A 181 gr (7,000 gr = 1 lb) bullet goes from rest to 3,347 ft/s in 0.0011 s. Determine the magnitude of the impulse imparted to the bullet during the given time interval. In addition, determine the magnitude of the average force acting on the bullet.



The magnitude of the impulse imparted to the bullet is lb·s and the magnitude of the average force acting on the bullet is lb.

Using impulse momentum

$$p_1 + \int_0^t F_{av}(t) dt = p_2$$

But $p_1 = mv_1 = 0$ since starting from rest and $p_2 = mv_2$, therefore

$$\begin{aligned} \int_0^t F_{av}(t) dt &= \left(\frac{181}{7000}\right) (3347) \\ &= 2.688 \text{ lb-sec} \end{aligned}$$

Therefore

$$\begin{aligned} F_{av}(0.0011) &= 2.688 \\ F_{av} &= \frac{2.688}{0.0011} \\ &= 2443.636 \text{ lb} \end{aligned}$$

6.7.2 Problem 2

The takeoff runway on carriers is much too short for a modern jetplane to take off on its own. For this reason, the takeoff of carrier planes is assisted by *hydraulic catapults* (Fig. A). The catapult system is housed below the deck except for a relatively small *shuttle* that slides along a rail in the middle of the runway (Fig. B). The front landing gear of carrier planes is equipped with a *tail hook* that, at takeoff, is attached to the catapult shuttle (Fig. C). When the catapult is activated, the shuttle pulls the airplane along the runway and helps the plane reach its takeoff speed. The takeoff runway is approximately 310 ft long, and most modern carriers have three or four catapults. If the carrier takeoff of a 45,500 lb plane subject to the 33,000 lb thrust of its engines were not assisted by a catapult, estimate how long it would take for a plane to safely take off, i.e., to reach a speed of 162 mph starting from rest. Also, how long a runway would be needed under these conditions?



Photo credit (A): U.S. Navy photo by Photographer's Mate 2nd Class H. Dwain Willis
Photo credit (B): PHAN James Farrally II, U.S. Navy

$$p_1 + \int_0^t T dt = p_2$$

Where T is the thrust. But $p_1 = 0$, therefore

$$\begin{aligned} Tt &= mv_2 \\ t &= \frac{mv_2}{T} \\ &= \frac{\left(\frac{45500}{32.2}\right)\left(162\left(\frac{5280}{3600}\right)\right)}{33000} \\ &= 10.174 \text{ sec} \end{aligned}$$

To find how long a runway is needed

$$x_f = x_1 + v_1t + \frac{1}{2}at^2$$

But $x_1 = 0$ and $a = \frac{v_2 - v_1}{t}$, and $v_1 = 0$ since starting from rest, hence

$$\begin{aligned} x_f &= \frac{1}{2}at^2 \\ &= \frac{1}{2}\left(\frac{v_2}{t}\right)t^2 \\ &= \frac{1}{2}v_2t \\ &= \left(\frac{1}{2}\right)162\left(\frac{5280}{3600}\right)(10.174) \\ &= 1208.671 \text{ ft} \end{aligned}$$

This is 4 times as long as without the catapults.

6.7.3 Problem 3



A $5\frac{1}{8}$ oz baseball traveling at 89 mph rebounds off a bat with a speed of 160 mph. The ball is in contact with the bat for roughly 10^{-3} s. The incoming velocity of the ball is horizontal, and the outgoing trajectory forms an angle $\alpha = 32^\circ$ with respect to the incoming trajectory.

Part 1

(a) Determine the impulse provided to the baseball by the bat. ✓

$$\text{Impulse} = (3.28 \hat{i} + 1.24 \hat{j}) \text{ lb} \cdot \text{s}$$

Part 2

(b) Determine the average force exerted by the bat on the ball. ✓

$$\vec{F}_{b \text{ avg}} = (3280 \hat{i} + 1240 \hat{j}) \text{ lb}$$

Part 3

(c) Determine how much the angle α would change (with respect to 32°) if we were to neglect the effects of the force of gravity on the ball. ✓

The angle α would change by $^\circ$ with respect to 32° .

$$\begin{aligned}\bar{p}_1 + \int_0^t \bar{F} dt &= \bar{p}_2 \\ -mv_1 \hat{i} + \int_0^t (F_x \hat{i} + F_y \hat{j}) dt &= mv_2 \cos \alpha \hat{i} + mv_2 \sin \alpha \hat{j} \\ \hat{i}(-mv_1 + F_x t) + \hat{j}(F_y t) &= mv_2 \cos \alpha \hat{i} + mv_2 \sin \alpha \hat{j}\end{aligned}$$

Hence we obtain two equations

$$\begin{aligned}-mv_1 + F_x t &= mv_2 \cos \alpha \\ F_y t &= mv_2 \sin \alpha\end{aligned}$$

Or

$$\begin{aligned}F_x t &= mv_2 \cos \alpha + mv_1 \\ F_y t &= mv_2 \sin \alpha\end{aligned}$$

Now $m = \frac{5.125}{32.2} = 0.00994$ slug, and $v_1 = 89 \left(\frac{5280}{3600} \right) = 130.533$ ft/sec and $v_2 = 160 \left(\frac{5280}{3600} \right) = 234.667$ ft/sec. Hence

$$\begin{aligned}F_x t &= (0.00994)(234.667) \cos \left(32 \left(\frac{\pi}{180} \right) \right) + (0.00994)(130.5333) \\ F_y t &= (0.00994)(234.667) \sin \left(32 \left(\frac{\pi}{180} \right) \right)\end{aligned}$$

Or

$$\begin{aligned}F_x t &= 1.978 + 1.298 = 3.276 \\ F_y &= 1.236\end{aligned}$$

Hence impulse is

$$\bar{I} = 3.276 \hat{i} + 1.236 \hat{j}$$

To find average force, we divide by time

$$\begin{aligned}\bar{F}_{av} &= \frac{3.276}{0.001} \hat{i} + \frac{1.236}{0.001} \hat{j} \\ &= 3276 \hat{i} + 1236 \hat{j}\end{aligned}$$

6.7.4 Problem 4

An 8,110 lb vehicle *A* traveling with a speed $v_A = 57$ mph collides head-on with a 2,070 lb vehicle *B* traveling in the opposite direction with a speed $v_B = 32$ mph. Determine the postimpact velocity of the two cars if the impact is perfectly plastic.

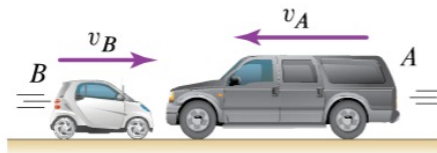

The postimpact velocity of car *A* is ft/s $\hat{i} + \text{} \hat{j}$ and the postimpact velocity of car *B* is ft/s $\hat{i} + \text{} \hat{j}$.

Since there is no external force, then $p_1 = p_2$ or

$$m_B v_B^- + m_A v_A^- = m_B v_B^+ + m_A v_A^+ \quad (1)$$

Where + means after impact and – means before impact. Therefore (using positive going

to the right)

$$v_A^- = -57 \left(\frac{5280}{3600} \right) = -83.6 \text{ ft/sec}$$

$$v_B^- = 32 \left(\frac{5280}{3600} \right) = 46.933 \text{ ft/sec}$$

$$m_A = \frac{8110}{32.2} = 251.8634 \text{ slug}$$

$$m_B = \frac{2070}{32.2} = 64.2857 \text{ slug}$$

Hence (1) becomes

$$\begin{aligned} (64.2857)(46.933) - (251.8634)(83.6) &= \frac{2070}{32.2}v_B^+ + \frac{8110}{32.2}v_A^+ \\ -18038.66 &= 64.286v_B^+ + 251.8634v_A^+ \end{aligned} \quad (2)$$

And since $e = 0$, then

$$\begin{aligned} e = 0 &= \frac{v_B^+ - v_A^+}{v_A^- - v_B^-} \\ v_B^+ &= v_A^+ \end{aligned} \quad (3)$$

Using (2,3) we solve for v_B^+, v_A^+ . Plug (3) into (2) gives

$$-18038.66 = 64.286v_A^+ + 251.8634v_A^+$$

$$-18038.66 = 316.1494v_A^+$$

$$\begin{aligned} v_A^+ &= \frac{-18038.66}{316.1494} \\ &= -57.05739 \text{ ft/sec} \end{aligned}$$

Hence

$$v_B^+ = -57.05739 \text{ ft/sec}$$

6.7.5 Problem 5

The ballistic pendulum used to be a common tool for the determination of the muzzle velocity of bullets as a measure of the performance of firearms and ammunition (nowadays, the ballistic pendulum has been replaced by the ballistic chronograph, an electronic device). The ballistic pendulum is a simple pendulum that allows one to record the maximum swing angle of the pendulum arm caused by the firing of a bullet into the pendulum bob. Let $L = 1.7$ m and $m_A = 5.8$ kg. For a certain historical pistol, which fired a roundball of mass $m_B = 90$ g, it is found that the maximum swing angle of the pendulum is $\theta_{\max} = 51^\circ$. Determine the preimpact speed of the bullet B .

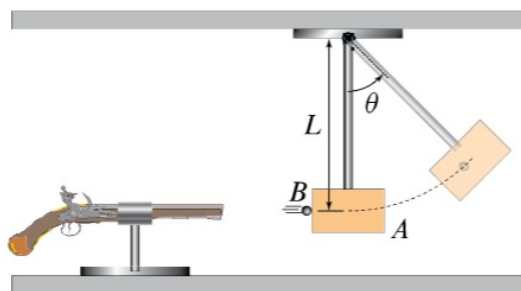

Let v_B^- be speed of bullet before impact. Assume that after impact bullet and mass A are stuck together with speed v^+ . Hence

$$m_B v_B^- = (m_B + m_A) v^+ \quad (1)$$

Now we apply work-energy. Hence

$$\frac{1}{2} (m_B + m_A) (v^+)^2 = (m_B + m_A) g (L - L \cos \theta) \quad (2)$$

Where datum is taken at the horizontal level. From (2) we solve for v^+ and use it in (1) to

find v_B^- . (2) becomes

$$\begin{aligned}\frac{1}{2}(0.09 + 5.8)(v^+)^2 &= (0.09 + 5.8)(9.81)(1.7)\left(1 - \cos\left(51\left(\frac{\pi}{180}\right)\right)\right) \\ 2.945(v^+)^2 &= 36.41094 \\ v^+ &= \sqrt{\frac{36.41094}{2.945}} \\ &= 3.516 \text{ m/sec}\end{aligned}$$

Then (1) becomes

$$\begin{aligned}0.09v_B^- &= (0.09 + 5.8)(3.516) \\ v_B^- &= \frac{(0.09 + 5.8)(3.516)}{0.09} \\ &= 230.103 \text{ m/sec}\end{aligned}$$

6.7.6 Problem 6

Car A , with $m_A = 1,524$ kg, is stopped at a red light. Car B , with $m_B = 1,860$ kg and a speed of 38 km/h, fails to stop before impacting car A . After impact, cars A and B slide over the pavement with a coefficient of friction $\mu_k = 0.67$. How far will the cars slide if the cars become entangled?

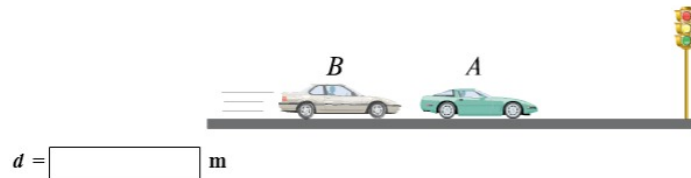

Applying impulse momentum

$$m_B v_B^- = (m_B + m_A) v^+$$

Solving for v^+

$$\begin{aligned}v^+ &= \frac{m_B v_B^-}{m_B + m_A} \\ &= \frac{(1860)\left(38\left(\frac{1000}{3600}\right)\right)}{1860 + 1524} \\ &= 5.802 \text{ m/sec}\end{aligned}$$

Now applying work-energy

$$T_1 + U^{12} = T_2$$

$$\frac{1}{2}(m_B + m_A)(v^+)^2 - \int_0^d \mu(m_B + m_A)g dx = 0$$

We now solve for d

$$\begin{aligned}\frac{1}{2}(1860 + 1524)(5.802)^2 - (0.67)(1860 + 1524)(9.81)d &= 0 \\ d &= \frac{\frac{1}{2}(1860 + 1524)(5.802)^2}{(0.67)(1860 + 1524)(9.81)} \\ &= 2.561 \text{ meter}\end{aligned}$$

6.8 HW 8

6.8.1 Problem 1

Ball B is stationary when it is hit by an identical ball A as shown, with $\beta = 45^\circ$. The preimpact speed of ball A is $v_0 = 9$ m/s.

Determine the postimpact velocity of ball B if the COR of the collision $e = 1$.

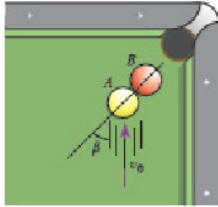

$$\vec{v}_B^+ = \boxed{} \hat{i} \text{ m/s. } \hat{j} - 45^\circ$$

The before and after impact diagram is

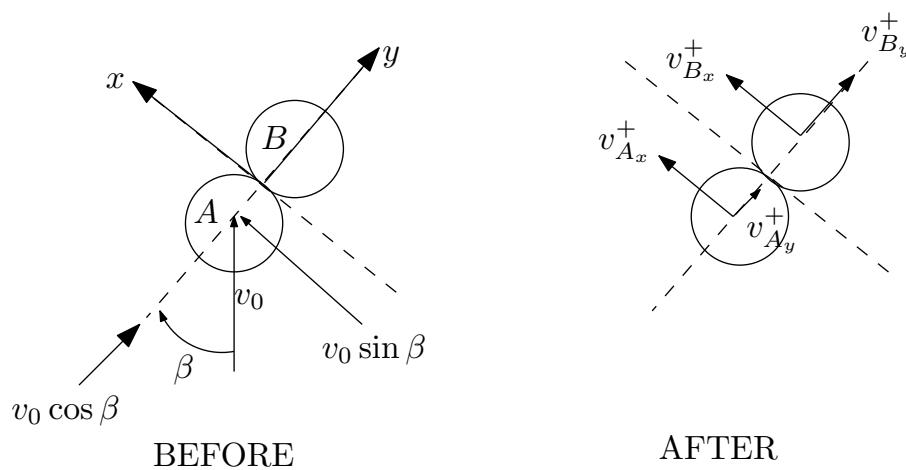

Along the y direction

$$m_A v_0 \cos \beta = m_A v_{A_y}^+ + m_B v_{B_y}^+$$

$$-e = -1 = \frac{v_{A_y}^+ - v_{B_y}^+}{v_{A_y}^- - v_{B_y}^-} = \frac{v_{A_y}^+ - v_{B_y}^+}{v_0 \cos \beta}$$

These are 2 equations with 2 unknowns $v_{A_y}^+, v_{B_y}^+$. From the second equation

$$-v_0 \cos \beta = v_{A_y}^+ - v_{B_y}^+ \quad (1)$$

Substituting this in the first equation (and canceling the mass since they are the same), gives

$$-v_{A_y}^+ + v_{B_y}^+ = v_{A_y}^+ + v_{B_y}^+$$

$$v_{A_y}^+ = 0$$

Therefore from (1)

$$v_{B_y}^+ = v_0 \cos \beta$$

$$= 9 \cos \left(45 \left(\frac{\pi}{180} \right) \right)$$

$$= 6.364 \text{ m/s}$$

Along the x direction, since this is perpendicular to the line of impact then we know that

$$v_{Ax}^+ = v_{Ax}^- = v_0 \sin \beta = 9 \sin \left(45 \left(\frac{\pi}{180} \right) \right) = 6.364 \text{ m/s}$$

$$v_{Bx}^+ = v_{Bx}^- = 0$$

Hence velocity of B is

$$\bar{v}_B = 0\hat{i} + 6.364\hat{j}$$

And velocity of A is

$$\bar{v}_A = 6.364\hat{i} + 0\hat{j}$$

6.8.2 Problem 2

Two spheres, A and B , with masses $m_A = 1.48 \text{ kg}$ and $m_B = 2.75 \text{ kg}$, respectively, collide with $v_A^- = 26.7 \text{ m/s}$, and $v_B^- = 22.6 \text{ m/s}$. Compute the postimpact velocities of A and B if $\alpha = 45^\circ, \beta = 15^\circ$, the COR is $e = 0.58$, and the contact between A and B is frictionless.

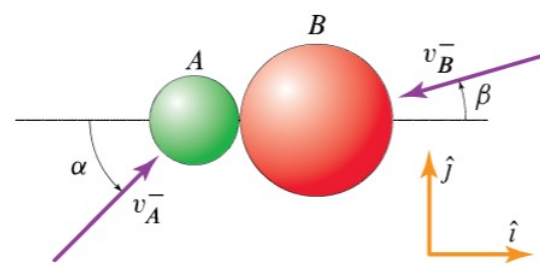

$\vec{v}_A^+ = (\text{ } \hat{i} + \text{ } \hat{j}) \text{ m/s}$
 $\vec{v}_B^+ = (\text{ } \hat{i} + \text{ } \hat{j}) \text{ m/s}$

The before and after impact diagram is

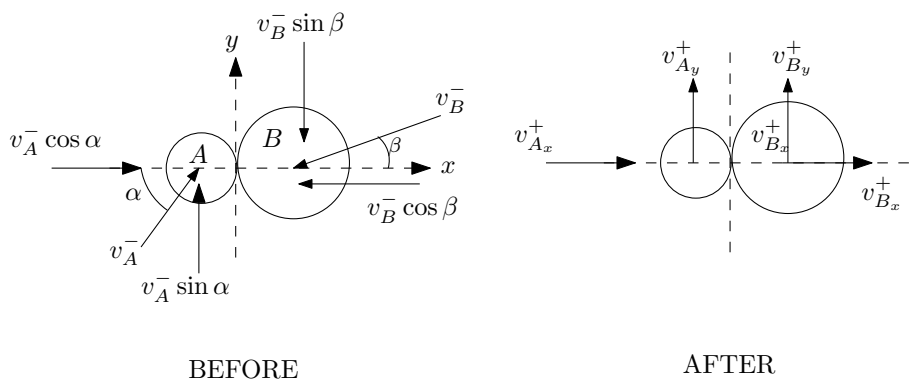

Along the x axis, the conservation of linear momentum gives

$$m_A v_A^- \cos \alpha - m_B v_B^- \cos \beta = m_A v_{Ax}^+ + m_B v_{Bx}^+$$

$$(1.48)(26.7) \cos \left(45 \left(\frac{\pi}{180} \right) \right) - (2.75)(22.6) \cos \left(15 \left(\frac{\pi}{180} \right) \right) = (1.48) v_{Ax}^+ + (2.75) v_{Bx}^+$$

$$-32.09 = (1.48) v_{Ax}^+ + (2.75) v_{Bx}^+ \quad (1)$$

And

$$\begin{aligned}
 -e &= \frac{v_{A_x}^+ - v_{B_x}^+}{v_{A_x}^- - v_{B_x}^-} \\
 -0.58 &= \frac{v_{A_x}^+ - v_{B_x}^+}{v_A^- \cos \alpha + v_B^- \cos \beta} \\
 -0.58 &= \frac{v_{A_x}^+ - v_{B_x}^+}{(26.7) \cos \left(45 \left(\frac{\pi}{180}\right)\right) + (22.6) \cos \left(15 \left(\frac{\pi}{180}\right)\right)} \\
 -0.58 &= \frac{v_{A_x}^+ - v_{B_x}^+}{40.71} \\
 -23.612 &= v_{A_x}^+ - v_{B_x}^+ \tag{2}
 \end{aligned}$$

Now $v_{A_x}^+, v_{B_x}^+$ is solved for using (1),(2). From (2) $v_{A_x}^+ = -23.612 + v_{B_x}^+$, substituting this in (1) gives

$$\begin{aligned}
 -32.09 &= (1.48) \left(-23.612 + v_{B_x}^+\right) + (2.75) v_{B_x}^+ \\
 -32.09 &= -34.945 + 4.23 v_{B_x}^+ \\
 v_{B_x}^+ &= \frac{-32.09 + 34.945}{4.23} \\
 &= 0.675 \text{ m/s}
 \end{aligned}$$

From (2)

$$\begin{aligned}
 v_{A_x}^+ &= -23.612 + 0.675 \\
 &= -22.937 \text{ m/s}
 \end{aligned}$$

Now we do the same for the y direction. But along this direction we know that

$$\begin{aligned}
 v_{A_y}^+ &= v_{A_y}^- \\
 &= v_A^- \sin \alpha \\
 &= (26.7) \sin \left(45 \left(\frac{\pi}{180}\right)\right) \\
 &= 18.88 \text{ m/s}
 \end{aligned}$$

And

$$\begin{aligned}
 v_{B_y}^+ &= v_{B_y}^- \\
 &= -v_B^- \sin \beta \\
 &= (-22.6) \sin \left(15 \left(\frac{\pi}{180}\right)\right) \\
 &= -5.849 \text{ m/s}
 \end{aligned}$$

Therefore, after impact

$$\begin{aligned}
 \bar{v}_A &= -22.938 \hat{i} + 18.879 \hat{j} \\
 \bar{v}_B &= 0.675 \hat{i} - 5.849 \hat{j}
 \end{aligned}$$

6.8.3 Problem 3

A rotor consists of four horizontal blades each of length $L = 4.5$ m and mass $m = 89$ kg cantilevered off of a vertical shaft. Assume that each blade can be modeled as having its mass concentrated at its midpoint. The rotor is initially at rest when it is subjected to a moment $M = \beta t$, with $\beta = 63$ N · m/s. Determine the angular speed of the rotor after 10 s.

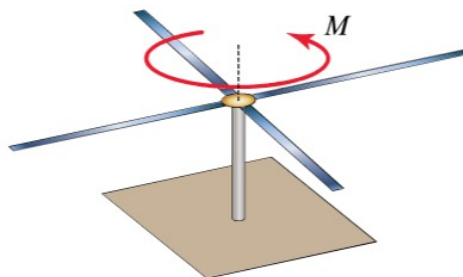

The angular speed is rad/s.

Using

$$\tau = 4I\ddot{\theta}$$

Where τ is applied torque and I is mass moment of inertia around the spin axis of one blade (we have 4). But $I = m\left(\frac{L}{2}\right)^2 = \frac{mL^2}{4}$, since blade is modeled as point mass. Therefore

$$\ddot{\theta} = \frac{\tau}{\frac{4mL^2}{4}} = \frac{\beta t}{mL^2}$$

But $\ddot{\theta} = \frac{d}{dt}\dot{\theta}$, then the above becomes

$$\begin{aligned} \frac{d}{dt}\dot{\theta} &= \frac{\beta t}{mL^2} \\ d\dot{\theta} &= \frac{\beta t}{mL^2} dt \\ \int_0^{\dot{\theta}_f} d\dot{\theta} &= \frac{\beta t}{mL^2} \int_0^{10} t dt \\ \dot{\theta}_f &= \frac{\beta}{mL^2} \left(\frac{t^2}{2}\right)_0^{10} \\ &= \frac{\beta}{2mL^2} 100 \\ &= \frac{(63)}{2(89)(4.5)^2} 100 \\ &= 1.748 \text{ rad/sec} \end{aligned}$$

6.8.4 Problem 4

The simple pendulum in the figure is released from rest as shown. Knowing that the bob's weight is $W = 1.8 \text{ lb}$, determine its angular momentum computed with respect to O as a function of the angle θ .

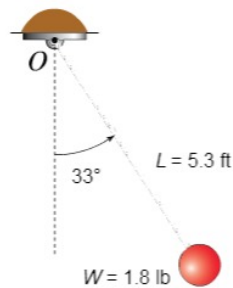

The angular momentum with respect to O is

$$\pm (\text{ } \text{lb} \cdot \text{ft} \cdot \text{s}) \sqrt{\cos \theta} - (\text{ } \text{ft} \cdot \text{s}) \hat{k} \cdot \hat{u}_\theta \hat{u}_r @ -57^\circ.$$

The angular momentum \bar{h} is the moment of the linear momentum. The linear momentum is $m\bar{v}$. Using radial and tangential coordinates, then

$$m\bar{v} = m(L\dot{\theta}\hat{u}_\theta + 0\hat{u}_r)$$

Therefore

$$\begin{aligned}
 \bar{h} &= \bar{r} \times m\bar{v} \\
 &= L\hat{u}_r \times mL\dot{\theta}\hat{u}_\theta \\
 &= \begin{vmatrix} \hat{u}_r & \hat{u}_\theta & \hat{k} \\ L & 0 & 0 \\ 0 & mL\dot{\theta} & 0 \end{vmatrix} \\
 &= \hat{k}mL^2\dot{\theta}
 \end{aligned} \tag{1}$$

The above is what we want. But we need to find $\dot{\theta}$. Taking time derivative of \bar{h} gives

$$\frac{d}{dt}\bar{h} = \hat{k}mL^2\ddot{\theta}$$

But $\frac{d}{dt}\bar{h}$ is the torque τ , which we can see to be

$$\tau = -mgL \sin \theta$$

The minus sign, since clockwise. Using the above 2 equations, then we write

$$\begin{aligned}
 -mgL \sin \theta &= mL^2\ddot{\theta} \\
 \ddot{\theta} &= -\frac{g}{L} \sin \theta
 \end{aligned} \tag{2}$$

To integrate this, we need a trick. Since

$$\begin{aligned}
 \ddot{\theta} &= \frac{d}{dt}\dot{\theta} \\
 &= \left(\frac{d}{d\theta} \frac{d\theta}{dt} \right) \dot{\theta} \\
 &= \left(\frac{d}{d\theta} \dot{\theta} \right) \dot{\theta} \\
 &= \dot{\theta} \frac{d\dot{\theta}}{d\theta}
 \end{aligned}$$

Then (2) becomes

$$\dot{\theta} \frac{d\dot{\theta}}{d\theta} = -\frac{g}{L} \sin \theta$$

Now it is separable.

$$\begin{aligned}
 \dot{\theta} d\dot{\theta} &= -\frac{g}{L} \sin \theta d\theta \\
 \int_0^{\dot{\theta}} \dot{\theta} d\dot{\theta} &= -\frac{g}{L} \int_{33^\circ}^{\theta} \sin \theta d\theta \\
 \frac{\dot{\theta}^2}{2} &= -\frac{g}{L} (-\cos \theta)_{33^\circ}^{\theta} \\
 \frac{\dot{\theta}^2}{2} &= \frac{g}{L} (\cos \theta - \cos 33^\circ) \\
 \dot{\theta} &= \pm \sqrt{\frac{2g}{L} (\cos \theta - \cos 33^\circ)}
 \end{aligned}$$

All this work was to find $\dot{\theta}$. Now we go back to (1) and find the angular momentum

$$\begin{aligned}
 \bar{h} &= \hat{k}mL^2\dot{\theta} \\
 &= \pm \hat{k} \sqrt{\frac{2g}{L} (\cos \theta - \cos 33^\circ)} mL^2 \\
 &= \pm \hat{k} \sqrt{2gL^3 (\cos \theta - \cos 33^\circ)} m \\
 &= \pm \hat{k} \sqrt{\frac{2L^3}{g} (\cos \theta - \cos 33^\circ)} W
 \end{aligned}$$

Substituting numerical values

$$\begin{aligned}\bar{h} &= \pm \hat{k} 1.8 \sqrt{\frac{2(5.3)^3}{(32.2)} \left(\cos \theta - \cos \left(33 \left(\frac{\pi}{180} \right) \right) \right)} \\ &= \pm \hat{k} 1.8 \sqrt{9.247 (\cos \theta - 0.839)} \\ &= \pm \hat{k} 1.8 \sqrt{9.247} \sqrt{(\cos \theta - 0.839)} \\ &= \pm 5.474 \sqrt{(\cos \theta - 0.839)} \hat{k}\end{aligned}$$

6.8.5 Problem 5

A collar with mass $m = 1.5$ kg is mounted on a rotating arm of negligible mass that is initially rotating with an angular velocity $\omega_0 = 1.6$ rad/s. The collar's initial distance from the z axis is $r_0 = 0.5$ m and $d = 1.9$ m. At some point, the restraint keeping the collar in place is removed so that the collar is allowed to slide. Assume that the friction between the arm and the collar is negligible. If no external forces and moments are applied to the system, with what speed will the collar impact the end of the arm?

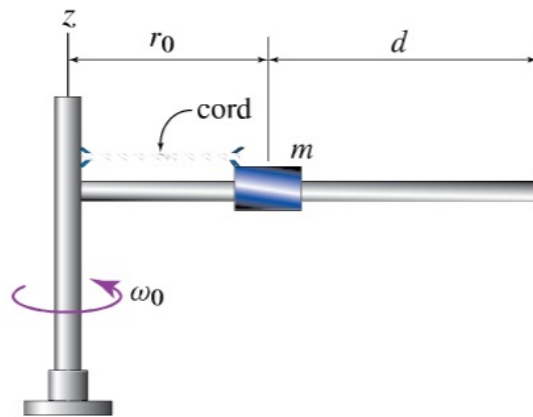

The collar will impact the end of the arm with a speed of m/s.

There is no external torque, hence angular momentum is conserved. Let \bar{h}_1 be the angular momentum initially and let \bar{h}_2 be angular momentum be at some instance of time later on. Therefore

$$\begin{aligned}\bar{h}_1 &= \bar{r}_1 \times m\bar{v}_1 \\ &= r_0 \hat{u}_r \times m(r_0 \omega_0 \hat{u}_\theta) \\ &= \begin{vmatrix} \hat{u}_r & \hat{u}_\theta & \hat{k} \\ r_0 & 0 & 0 \\ 0 & mr_0 \omega_0 & 0 \end{vmatrix} \\ &= mr_0^2 \omega_0 \hat{k}\end{aligned}$$

And at some later instance

$$\begin{aligned}\bar{h}_2 &= \bar{r}_2 \times m\bar{v}_2 \\ &= r \hat{u}_r \times m(\dot{r} \hat{u}_r + r\omega \hat{u}_\theta) \\ &= \begin{vmatrix} \hat{u}_r & \hat{u}_\theta & \hat{k} \\ r & 0 & 0 \\ m\dot{r} & mr\omega & 0 \end{vmatrix} \\ &= mr^2 \omega \hat{k}\end{aligned}$$

Equating the last two results gives

$$\begin{aligned} mr_0^2\omega_0 &= mr^2\omega \\ \omega &= \left(\frac{r_0}{r}\right)^2 \omega_0 \end{aligned} \quad (1)$$

Now the equation of motion in radial direction is $F = ma_r$, but $F = 0$, since there is no force on the collar. Therefore

$$\begin{aligned} ma_r &= 0 \\ m(\ddot{r} - r\omega^2) &= 0 \\ \ddot{r} &= r\omega^2 \end{aligned}$$

Using (1) in the above

$$\begin{aligned} \ddot{r} &= r \left[\left(\frac{r_0}{r}\right)^2 \right]^2 \omega_0^2 \\ \ddot{r} &= \frac{r_0^4}{r^3} \omega_0^2 \end{aligned}$$

But $\dot{r} = r \frac{dr}{dr}$, hence the above becomes

$$r \dot{r} = \frac{r_0^4}{r^3} \omega_0^2 dr$$

Now we can integrate

$$\begin{aligned} \int_0^{\dot{r}} r \dot{r} &= \int_{r_0}^r \frac{r_0^4}{r^3} \omega_0^2 dr \\ \frac{\dot{r}^2}{2} &= \frac{1}{2} \omega_0^2 r_0^4 \left(\frac{-1}{r^2} \right)_{r_0}^r \\ &= \frac{1}{2} \omega_0^2 r_0^4 \left(\frac{1}{r_0^2} - \frac{1}{r^2} \right) \end{aligned}$$

Therefore

$$\dot{r} = \omega_0 r_0^2 \sqrt{\left(\frac{1}{r_0^2} - \frac{1}{r^2} \right)}$$

To find \dot{r} when it hits the end, we just need to replace r by $r_0 + d$ in the above

$$\dot{r}_{end} = \omega_0 r_0^2 \sqrt{\frac{1}{r_0^2} - \frac{1}{(r_0 + d)^2}}$$

Numerically the above is

$$\begin{aligned} \dot{r}_{end} &= (1.6)(0.5)^2 \sqrt{\left(\frac{1}{(0.5)^2} - \frac{1}{(0.5 + 1.9)^2} \right)} \\ &= 0.782 \text{ m/s} \end{aligned}$$

6.8.6 Problem 6

The body of the satellite shown has a weight that is negligible with respect to the two spheres A and B that are rigidly attached to it, which weigh 172 lb each. The distance from the spin axis of the satellite to A and B is $R = 3.7$ ft. Inside the satellite there are two spheres C and D weighing 4.3 lb mounted on a motor that allows them to spin about the axis of the cylinder at a distance $r = 0.75$ ft from the spin axis. Suppose that the satellite is released from rest and that the internal motor is made to spin up the internal masses at a constant angular acceleration of 4.7 rad/s^2 for a total of 12 s. Treating the system as isolated, determine the angular speed of the satellite at the end of spin-up.

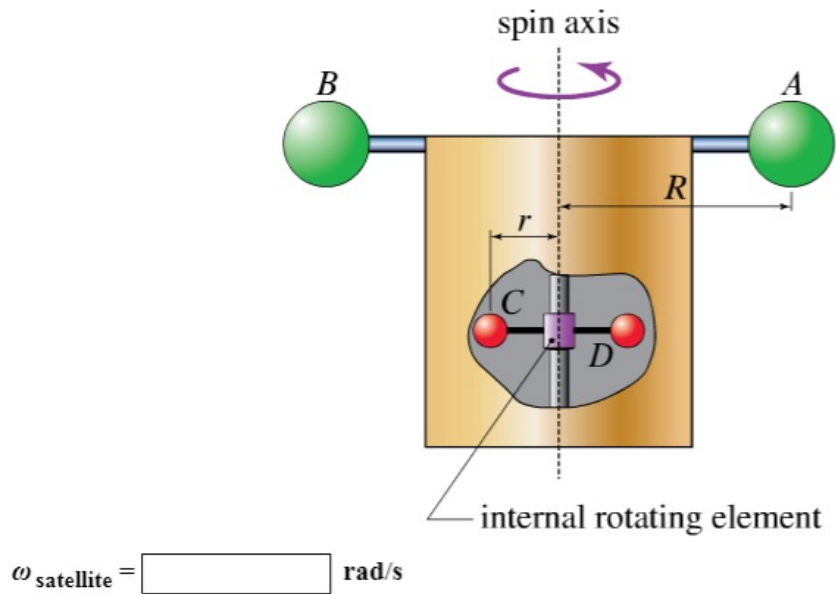

Using

$$\bar{h}_1 + \int_0^t \tau dt = \bar{h}_2$$

Where \bar{h}_1 is initial angular momentum which is zero, and \bar{h}_2 is final angular momentum which is $I\omega_f$ where $I = 2MR^2$ where M is mass of large ball and I is the mass moment of inertial of the large ball about the spin axis.

But torque $\tau = I_2\ddot{\theta}$ where $I_2 = 2(mr^2)$ where m is mass of each small ball and I_2 is the mass moment of inertial of the small ball about the spin axis. Hence the above becomes

$$\int_0^t \tau dt = \bar{h}_2$$

$$2(mr^2)\ddot{\theta} \int_0^t dt = \bar{h}_2$$

Since $\ddot{\theta}$ is constant. Hence

$$2(mr^2)\ddot{\theta}t = 2MR^2\omega_f$$

Solving for final angular velocity

$$\omega_f = \frac{2(mr^2)\ddot{\theta}t}{2MR^2}$$

$$= \frac{2\left(\frac{4.3}{32.2}\right)(0.75)^2(4.7)(12)}{2\left(\frac{172}{32.2}\right)(3.7)^2}$$

$$= 0.05793 \text{ rad/sec}$$

6.9 HW 9

6.9.1 Problem 1

Letting $R_A = 201$ mm, $R_B = 114$ mm, $R_C = 162$ mm, and $R_D = 133$ mm, determine the angular acceleration of gears B , C , and D when gear A has an angular acceleration with magnitude $|\alpha_A| = 51$ rad/s² in the direction shown. Note that gears B and C are mounted on the same shaft and they rotate as a unit.

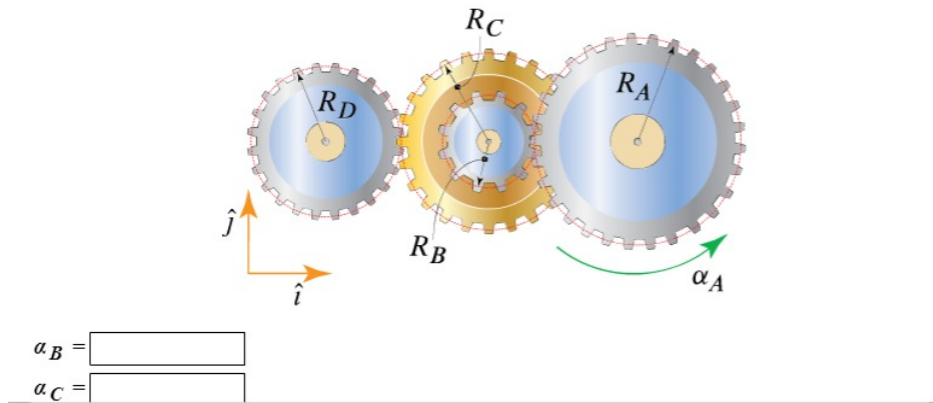

The tangential acceleration at the point where disk A and disk B meet is $R_A\alpha_A$. But this is also must be the same as $R_B\alpha_B$ since the gears assumed not to slip against each others. Therefore

$$\alpha_B = -\frac{R_A}{R_B}\alpha_A$$

The minus sign, is because gear A moves anti-clockwise, but B moves clockwise, hence in negative direction. Therefore

$$\begin{aligned}\alpha_B &= -\frac{201}{114}(51) \\ &= -89.921 \text{ rad/sec}^2\end{aligned}$$

Since C moves with B as one body, then $\alpha_B = \alpha_C$ and then

$$\alpha_C = -89.921 \text{ rad/sec}^2$$

Similarly

$$\begin{aligned}\alpha_D &= -\frac{R_C}{R_D}\alpha_C \\ &= -\frac{162}{133}(-89.921) \\ &= 109.528 \text{ rad/sec}^2\end{aligned}$$

6.9.2 Problem 2

At the instant shown the paper is being unrolled with a speed $v_p = 9.2$ m/s and an acceleration $a_p = 1$ m/s². If at this instant the outer radius of the roll is $r = 1.31$ m, determine the angular velocity ω_s and acceleration α_s of the roll.

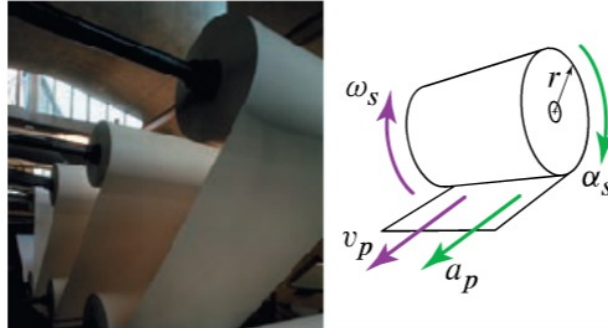

Since $a_p = r\alpha_s$ then

$$\alpha_s = -\frac{a_p}{r} = -\frac{1}{1.31} = -0.763 \text{ rad/sec}^2$$

Since $v_p = r\omega_s$ then

$$\omega_s = -\frac{v_p}{r} = -\frac{9.2}{1.31} = -7.023 \text{ rad/sec}$$

6.9.3 Problem 3

A bicycle has wheels 720 mm in diameter and a gear set with the dimensions given in the table below.

Crank			
Sprocket	C1	C2	C3
No. of Cogs	26	36	48
Radius (mm)	57.1	79.1	105.5

Cassette (9 speeds)									
Sprocket	S1	S2	S3	S4	S5	S6	S7	S8	S9
No. of Cogs	11	12	14	16	18	21	24	28	34
Radius (mm)	24.2	26.4	30.8	35.2	39.6	46.2	52.7	61.5	74.7

If a cyclist has a cadence of 1 Hz, determine the angular speed of the rear wheel in rpm when using the combination of C3 and S2. In addition, knowing that the speed of the cyclist is equal to the speed of a point on the tire relative to the wheel's center, determine the cyclist's speed in m/s.

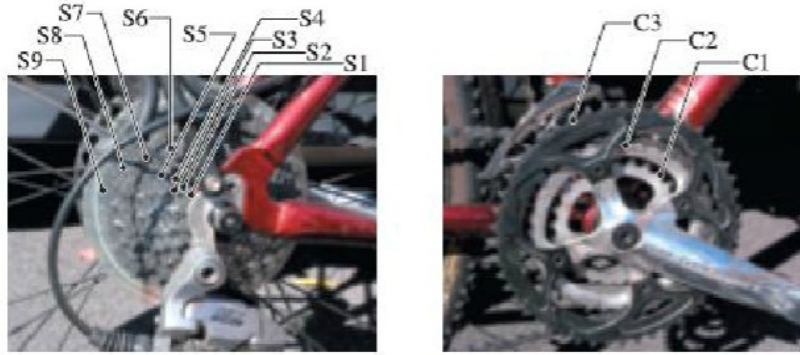

$$\omega_w = \boxed{} \text{ rpm}$$

$$v_{cyclist} = \boxed{} \text{ m/s}$$

$$RC = 105.5 \text{ mm}$$

$$RS = 26.4 \text{ mm}$$

$$RW = \frac{720}{2} = 360 \text{ mm}$$

$$\omega_C = 2\pi$$

Hence

$$\begin{aligned} \omega_{wheel} &= \frac{RC}{RS} \omega_C \\ &= \frac{105.5}{26.4} 2\pi \\ &= 25.109 \text{ rad/sec} \end{aligned}$$

Or

$$\begin{aligned} \omega_{wheel} &= \frac{25.109}{0.104719775} \\ &= 239.773 \text{ RPM} \end{aligned}$$

Hence

$$\begin{aligned} V &= \omega_{wheel} (RW) \\ &= 25.109 (360 (10^{-3})) \\ &= 9.039 \text{ m/s} \end{aligned}$$

6.9.4 Problem 4

A carrier is maneuvering so that, at the instant shown, $|\vec{v}_A| = 30$ knots (1 kn is exactly equal to 1.852 km/h) and $\phi = 34^\circ$. Letting the distance between A and B be 231 m and $\theta = 20^\circ$, determine \vec{v}_B at the given instant if the ship's turning rate at this instant is $\dot{\theta} = 2^\circ/\text{s}$ clockwise.

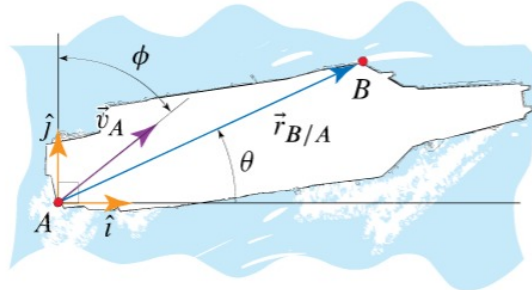

$$\vec{v}_B = (\text{ } \hat{i} + \text{ } \hat{j}) \text{ m/s}$$

$$\begin{aligned} \vec{v}_B &= \vec{v}_A + \vec{\omega} \times \vec{r}_{B/A} \\ &= v_A (\sin \phi \hat{i} + \cos \phi \hat{j}) + \vec{\omega} \times \vec{r}_{B/A} \end{aligned} \quad (1)$$

And

$$\vec{\omega} = -2^\circ \hat{k} = -0.03491 \hat{k}$$

And

$$\vec{r}_{B/A} = d \cos \theta \hat{i} + d \sin \theta \hat{j}$$

Hence (1) becomes

$$\begin{aligned} \vec{v}_B &= v_A (\sin \phi \hat{i} + \cos \phi \hat{j}) + \omega \hat{k} \times (d \cos \theta \hat{i} + d \sin \theta \hat{j}) \\ &= v_A (\sin \phi \hat{i} + \cos \phi \hat{j}) + \begin{vmatrix} \hat{i} & \hat{j} & \hat{k} \\ 0 & 0 & \omega \\ d \cos \theta & d \sin \theta & 0 \end{vmatrix} \\ &= v_A (\sin \phi \hat{i} + \cos \phi \hat{j}) + (-\omega d \sin \theta \hat{i} - \hat{j}(-\omega d \cos \theta)) \\ &= \hat{i}(v_A \sin \phi - \omega d \sin \theta) + \hat{j}(v_A \cos \phi + \omega d \cos \theta) \end{aligned} \quad (2)$$

But

$$\begin{aligned} v_A &= 30 (1.852) \left(\frac{1000}{\text{km}} \right) \left(\frac{\text{hr}}{3600} \right) \\ &= 30 (1.852) \left(\frac{1000}{3600} \right) \\ &= 15.433 \text{ m/s} \end{aligned}$$

And $d = 231$, hence (2) becomes

$$\begin{aligned} \vec{v}_B &= \hat{i} \left((15.433) \sin \left(34 \left(\frac{\pi}{180} \right) \right) - (-0.0349) (231) \sin \left(20 \left(\frac{\pi}{180} \right) \right) \right) \\ &\quad + \hat{j} \left((15.433) \cos \left(34 \left(\frac{\pi}{180} \right) \right) + (-0.0349) (231) \cos \left(20 \left(\frac{\pi}{180} \right) \right) \right) \end{aligned}$$

Or

$$\vec{v}_B = 11.388 \hat{i} + 5.217 \hat{j}$$

6.9.5 Problem 5

At the instant shown the lower rack is moving to the right with a speed of $v_L = 5$ ft/s, while the upper rack is fixed. If the nominal radius of the pinion is $R = 2.3$ in, determine ω_P , the angular velocity of the pinion, as well as the velocity of point O , i.e., the center of the pinion.

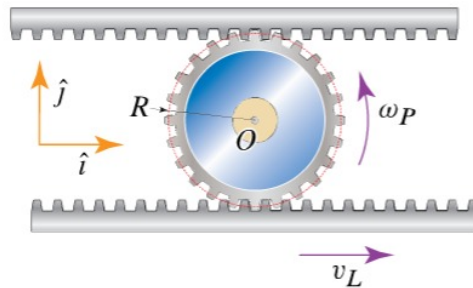

$$\vec{\omega}_P = \boxed{} \hat{k} \text{ rad/s.}$$

$$\vec{v}_O = \boxed{} \hat{i} \text{ ft/s.}$$

$$\begin{aligned} \omega_p(2R) &= v_L \\ \omega_p &= \frac{v_L}{2R} \\ &= \frac{5}{2\left(\frac{2.3}{12}\right)} = 13.043 \text{ rad/sec} \end{aligned}$$

And

$$\begin{aligned} v_o &= \omega_p R \\ &= 13.04348 \left(\frac{2.3}{12}\right) \\ &= 2.5 \text{ m/s} \end{aligned}$$

6.9.6 Problem 6

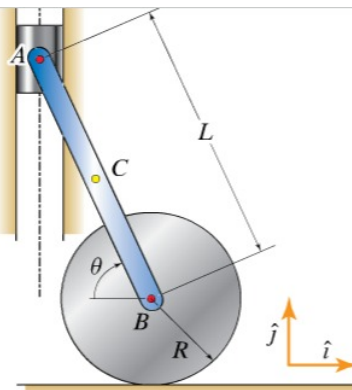

The system shown consists of a wheel of radius $R = 12$ in. rolling on a horizontal surface. A bar AB of length $L = 35$ in. is pin-connected to the center of the wheel and to a slider A that is constrained to move along a vertical guide. Point C is the bar's midpoint. If, when $\theta = 77^\circ$, the wheel is moving to the right so that $v_B = 5$ ft/s, determine the angular velocity of the bar as well as the velocity of the slider A .

$$\begin{aligned}\vec{\omega}_{AB} &= \boxed{} \hat{k} \text{ rad/s} \\ \vec{v}_A &= \boxed{} \hat{j} \text{ ft/s}\end{aligned}$$

Since

$$\omega L \sin \theta = v_B$$

Then

$$\begin{aligned}\omega &= \frac{v_B}{L \sin \theta} \\ &= \frac{5}{\left(\frac{35}{12}\right) \sin\left(77\left(\frac{\pi}{180}\right)\right)} \\ &= 1.759 \text{ rad/sec}\end{aligned}$$

And

$$\omega L \cos \theta = v_A$$

Then

$$\begin{aligned}v_A &= -(1.759) \left(\frac{35}{12}\right) \cos\left(77\frac{\pi}{180}\right) \\ &= -1.154 \text{ m/s}\end{aligned}$$

The minus sign since A moves down.

This can also be solved using vector method as follows

$$\vec{v}_A = \vec{v}_B + \vec{\omega}_{AB} \times \vec{r}_{A/B}$$

Where $\vec{r}_{A/B} = -L \cos \theta \hat{i} + L \sin \theta \hat{j}$ and $\vec{v}_B = 5 \hat{i}$ is given. Hence the above becomes

$$\begin{aligned}\vec{v}_A &= 5 \hat{i} + \omega_{AB} \hat{k} \times (-L \cos \theta \hat{i} + L \sin \theta \hat{j}) \\ &= 5 \hat{i} + (-\omega_{AB} L \cos \theta \hat{j} - \omega_{AB} L \sin \theta \hat{i}) \\ &= \hat{i}(5 - \omega_{AB} L \sin \theta) + \hat{j}(-\omega_{AB} L \cos \theta)\end{aligned}\tag{1}$$

And now comes the main point. We argue that A can only move in vertical direction, hence the \hat{i} component above must be zero. Therefore

$$5 - \omega_{AB} L \sin \theta = 0$$

There is only one unknown in the above. Solving for ω_{AB} gives

$$\omega_{AB} = 1.759 \text{ rad/sec}$$

Now we go back to (1) and find \vec{v}_A

$$\begin{aligned}\vec{v}_A &= \hat{i}(0) - \hat{j}\left(1.759 \left(\frac{35}{12}\right) \cos\left(77\frac{\pi}{180}\right)\right) \\ &= \hat{i}(0) - \hat{j}(1.154)\end{aligned}$$

Which is the same as method earlier. Notice we did not need to use R , the radius of the disk.

6.10 HW 10

6.10.1 Problem 1

The system shown consists of a wheel of radius $R = 5$ in. rolling on a horizontal surface. A bar AB of length $R = 33$ in. is pin-connected to the center of the wheel and to a slider A that is constrained to move along a vertical guide. Point C is the bar's midpoint. If the wheel rolls without slip with a constant counterclockwise angular velocity of 15 rad/s, determine the velocity of the slider A when $\theta = 48^\circ$.

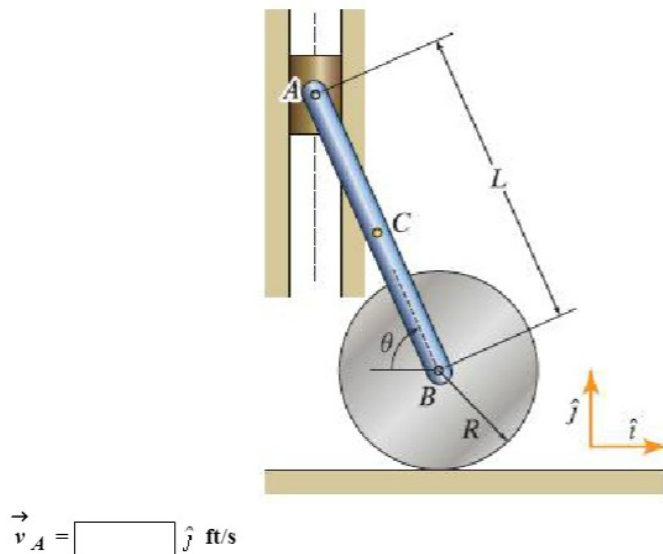

Since the wheel rolls without slip with angular velocity $\omega_{disk} = 15$ rad/sec and its radius is $r = \frac{5}{12}$ ft, then the center of the wheel moves to the left (since disk is rolling with counter clock wise) with velocity

$$\begin{aligned} V_B &= r\omega_{disk} \\ &= \left(\frac{5}{12}\right)(15) \\ &= 6.25 \text{ ft/sec} \end{aligned}$$

In vector format

$$\vec{V}_B = -6.25\hat{i} + 0\hat{j}$$

For the point A

$$\begin{aligned} \vec{V}_A &= \vec{V}_B + \vec{\omega}_{AB} \times \vec{r}_{A/B} \\ &= (-6.25\hat{i} + 0\hat{j}) + \omega_{AB}\hat{k} \times (-L \cos \theta \hat{i} + L \sin \theta \hat{j}) \\ &= -6.25\hat{i} - \omega_{AB}L \cos \theta \hat{j} - \omega_{AB}L \sin \theta \hat{i} \\ &= \hat{i}(-6.25 - \omega_{AB}L \sin \theta) + \hat{j}(-\omega_{AB}L \cos \theta) \end{aligned} \quad (1)$$

Since point A can only move in vertical direction, then its \hat{i} component above must be zero. Therefore

$$\begin{aligned} -6.25 - \omega_{AB}L \sin \theta &= 0 \\ \omega_{AB} &= \frac{-6.25}{L \sin \theta} \end{aligned}$$

Numerically $\omega_{AB} = \frac{-6.25}{\left(\frac{33}{12}\right) \sin\left(48\left(\frac{\pi}{180}\right)\right)} = -3.058$ rad/sec.

Now from (1) we find \vec{V}_A since now we know ω_{AB}

$$\begin{aligned}\vec{V}_A &= \hat{j}(-\omega_{AB}L \cos \theta) \\ &= \hat{j}\left(\frac{6.25}{L \sin \theta}L \cos \theta\right) \\ &= \hat{j}\left(\frac{6.25}{\tan \theta}\right)\end{aligned}$$

Since $\theta = 48^\circ$ then the above becomes

$$\begin{aligned}\vec{V}_A &= \frac{6.25}{\tan\left(48\left(\frac{\pi}{180}\right)\right)}\hat{j} \\ &= 5.627525\hat{j} \\ &= 5.628\hat{j} \text{ ft/sec}\end{aligned}$$

6.10.2 Problem 2

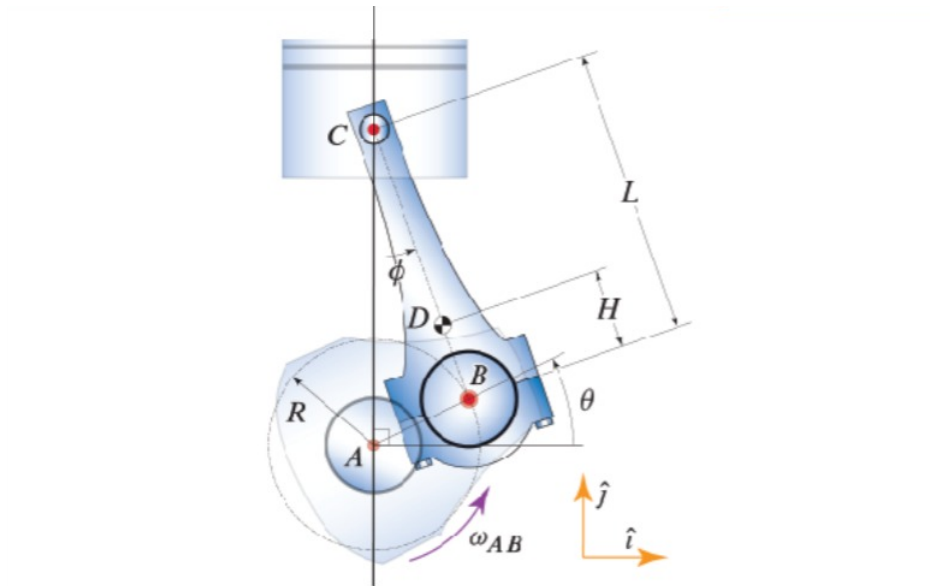

For the slider-crank mechanism shown, let $R = 2.3$ in., $L = 5.3$ in., and $H = 1.5$ in. Also, at the instant shown, let $\theta = 26^\circ$ and $\omega_{AB} = 4,890$ rpm.

Determine the velocity of the piston at the instant shown.

$$v_C = \boxed{} \hat{j} \text{ ft/s}$$

The first step is to find the vector velocities of point B and C and then resolve them along the x, y directions as follows

In vector form

$$\vec{V}_C = 106.441\hat{j}$$

6.10.3 Problem 3

At the instant shown, an overhead garage door is being shut with point B moving to the left within the horizontal part of the door guide at a speed of 6 ft/s, while point A is moving vertically downward. Determine the angular velocity of the door and the velocity of the counterweight C at this instant if $L = 6$ ft and $d = 1.8$ ft.

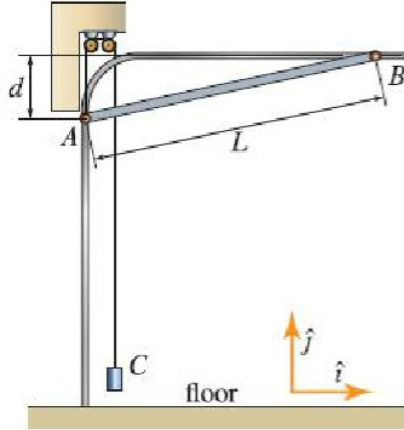

$$\vec{\omega}_{AB} = \boxed{} \hat{k} \text{ rad/s}$$

$$\vec{v}_C = \boxed{} \hat{j} \text{ ft/s}$$

The first step is to find the vector velocities of point A and B and then resolve them along the x, y directions as follows

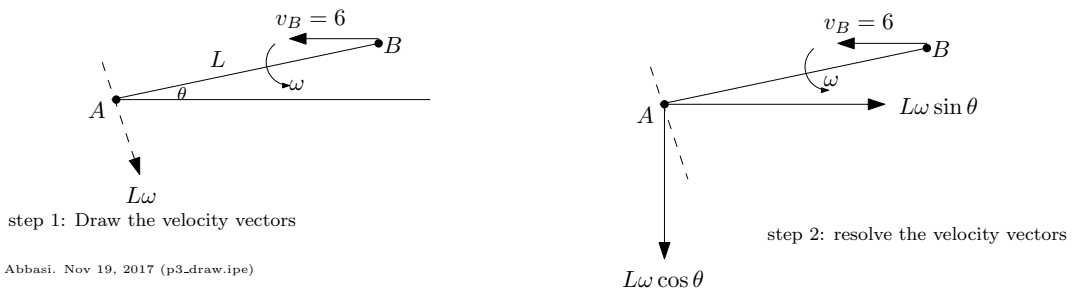

Point A will have velocity in x direction of

$$V_{A,x} = L\omega \sin \theta - V_{Bx}$$

But $\sin \theta = \frac{d}{L} = \frac{1.8}{6} = 0.3$, hence $\theta = \arcsin(0.3) = 17.458^\circ$. Since A can only move in vertical direction, then the above is zero. We use this to find ω

$$L\omega \sin \theta - V_{Bx} = 0$$

$$\omega = \frac{V_{Bx}}{L \sin \theta}$$

$$= \frac{6}{6 \sin \left(17.458 \left(\frac{\pi}{180} \right) \right)}$$

$$= 3.333 \text{ rad/sec}$$

In vector format $\vec{\omega} = 3.333\hat{k}$ rad/sec. Hence the velocity of A in vertical direction is

$$\begin{aligned} V_{Ay} &= -L\omega \cos \theta \\ &= -6(3.333) \cos 17.458 \left(\frac{\pi}{180} \right) \\ &= -19.07683 \text{ ft/sec} \end{aligned}$$

In vector format

$$\vec{V}_A = -19.077\hat{j}$$

This is the same velocity as weight C but C will be going up. Hence

$$\vec{V}_C = 19.077\hat{j}$$

6.10.4 Problem 4

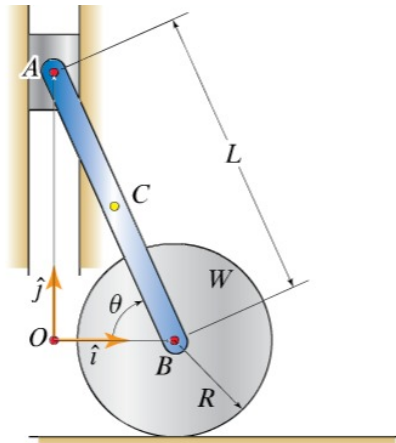

The system shown consists of a wheel of radius $R = 1.58$ m rolling without slip on a horizontal surface. A bar, AB , of length $L = 3.43$ m is pin-connected to the center of the wheel and to a slider, A , constrained to move along a vertical guide. Point C is the bar's midpoint.

If the wheel is rolling clockwise with a constant angular speed of 2.1 rad/s, determine the angular acceleration of the bar when $\theta = 69^\circ$.

$$\vec{\alpha} = \boxed{} \hat{i} + \boxed{} \hat{j} \frac{\text{rad}}{\text{s}^2}$$

The first step is to find the acceleration vectors of point A and B and then resolve them along the x, y directions as follows

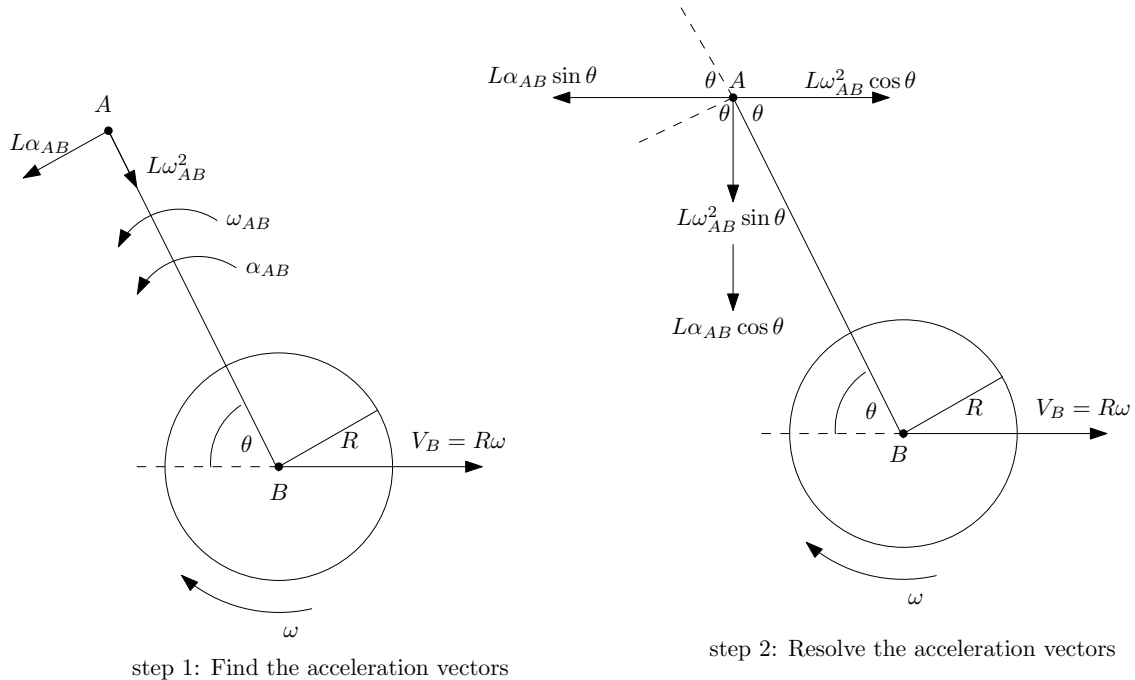

p4_draw.ipeNasser M. Abbasi Nov 19, 2017

step 2: Resolve along x and y directions

To find ω_{AB} we need to resolve velocity vectors and set the x component of the velocity of A to zero to solve for ω_{AB} . If we do that as before, we get

$$V_{B_x} - L\omega_{AB} \sin \theta = 0 \quad (1)$$

The above is just the x component of \vec{V}_A . We know V_B which is velocity of center of wheel. It is

$$\begin{aligned} V_{B_x} &= R\omega_{disk} \\ &= 1.58 \text{ (2.1)} \\ &= 3.318 \text{ m/s} \end{aligned}$$

And to the right. Hence $\vec{V}_B = 3.318\hat{i}$. Now we use (1) to solve for ω_{AB}

$$\begin{aligned} \omega_{AB} &= \frac{V_{B_x}}{L \sin \theta} = \frac{3.318}{(3.43) \sin\left(69\frac{\pi}{180}\right)} \\ &= 1.0362 \text{ rad/sec} \end{aligned}$$

Hence $\vec{\omega}_{AB} = 1.0362\hat{k}$. Now we have all the information to solve for α_{AB} . The x component of \vec{a}_A is zero, since A does not move in x direction. Hence from the figure, we see that

$$L\omega_{AB}^2 \cos \theta - L\alpha_{AB} \sin \theta = 0$$

There is no acceleration to transfer from point B since B is not accelerating. Solving the above for α_{AB} gives

$$\begin{aligned} \alpha_{AB} &= \frac{L\omega_{AB}^2 \cos \theta}{L \sin \theta} \\ &= \frac{\omega_{AB}^2}{\tan \theta} \\ &= \frac{1.0362^2}{\tan\left(69\frac{\pi}{180}\right)} \\ &= 0.41216 \text{ rad/sec}^2 \end{aligned}$$

In vector format $\vec{\alpha}_{AB} = 0.41216\hat{k}$. Hence the vertical component of the acceleration \vec{a}_A is

(from the diagram)

$$\begin{aligned} a_{Ay} &= -L\omega_{AB}^2 \sin \theta - L\alpha_{AB} \cos \theta \\ &= -(3.43) \left(1.0362^2\right) \sin \left(69\frac{\pi}{180}\right) - (3.43) (0.41216) \cos \left(69\frac{\pi}{180}\right) \\ &= -3.945 \text{ m/s}^2 \end{aligned}$$

In vector format

$$\vec{a}_A = 0\hat{i} - 3.945\hat{j}$$

6.10.5 Problem 5

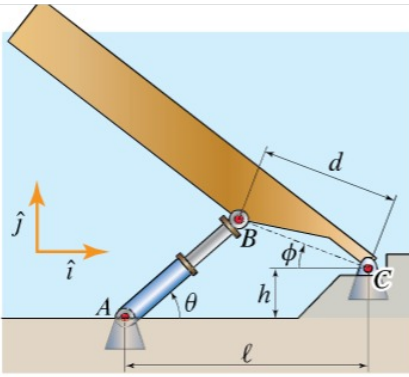

A flood gate is controlled via the hydraulic cylinder AB . If the length of the cylinder is increased with a constant time rate of 2.4 ft/s , determine the angular acceleration of the gate when $\phi = 0^\circ$. Let $\ell = 10.0 \text{ ft}$, $h = 2.2 \text{ ft}$, and $d = 4.7 \text{ ft}$.

$\vec{a}_{\text{gate}} =$ rad/s^2

$$\vec{\alpha}_{BC} = 7.507\hat{k} \text{ rad/sec}^2$$

Need to type the solution. This uses constraints method.

6.10.6 Problem 6

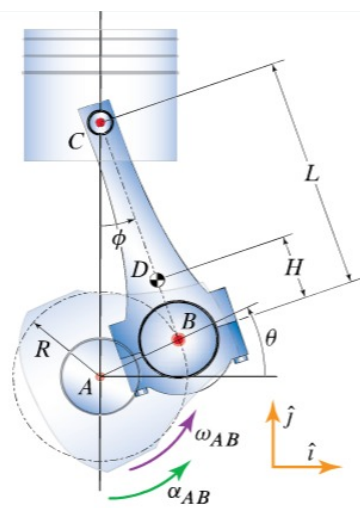

For the slider-crank mechanism shown above, let $R = 2.1 \text{ in.}$, $L = 5.8 \text{ in.}$, and $H = 1.3 \text{ in.}$ Assuming that $\omega_{AB} = 5,030 \text{ rpm}$ and is constant, determine the angular acceleration of the

connecting rod, BC , and the acceleration of point C at the instant when $\theta = 28^\circ$.

$$\vec{a}_C = \boxed{} \boxed{} \text{ ft/s}^2$$

$$\vec{\alpha}_{BC} = \boxed{} \boxed{} \text{ rad/s}^2$$

We need to first find ω_{BC} . This follows similar approach to problem 2. The first step is to find the vector velocities of point B and C and then resolve them along the x, y directions as follows

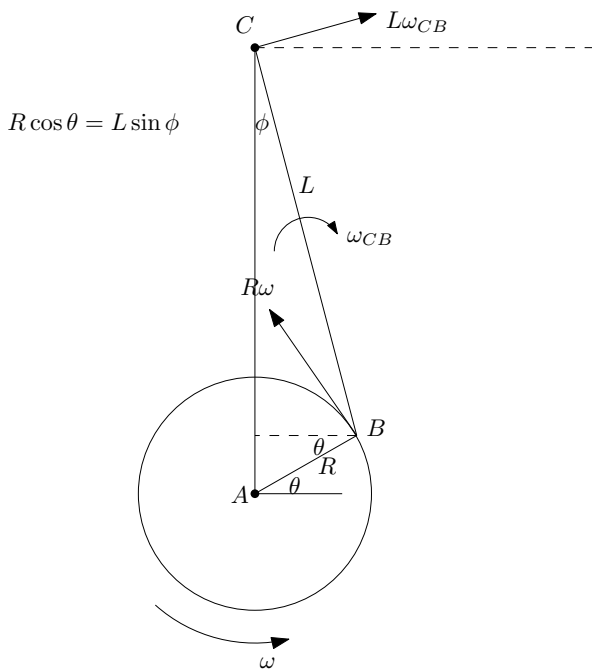

step 1: Find the vector velocities

p2_draw_1.ipe Nasser M. Abbasi Nov 19, 2017

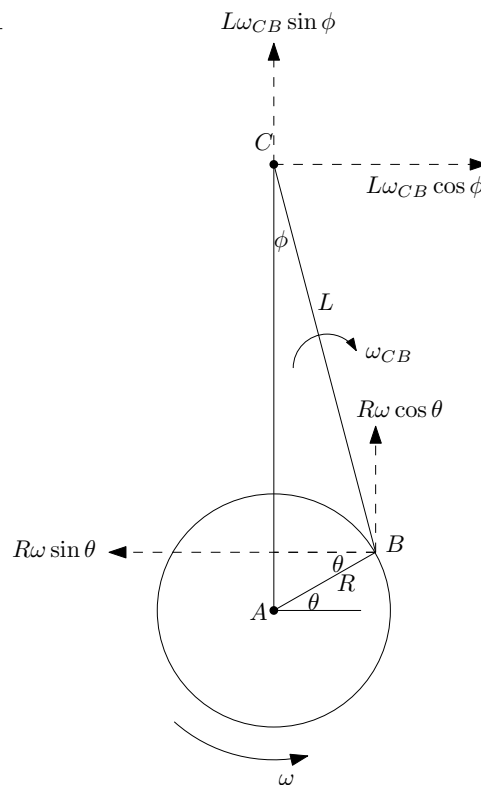

step 2: Resolve along x and y directions

Now we look at point C . We see that its x component of the velocity is

$$V_{C_x} = L\omega_{CB} \cos \phi - R\omega \sin \theta$$

This is just read from the diagram. In other words, the x component of the velocity of B is added. Since C can only move in the vertical direction, then $V_{C_x} = 0$. We use this to solve for ω_{CB}

$$\omega_{CB} = \frac{R\omega \sin \theta}{L \cos \phi} \tag{1}$$

Everything on the right above is known. We find ϕ using $R \cos \theta = L \sin \phi$, hence

$$\begin{aligned} \phi &= \arcsin\left(\frac{R \cos \theta}{L}\right) \\ &= \arcsin\left(\frac{(2.1) \cos\left(28 \frac{\pi}{180}\right)}{5.8}\right) \\ &= 0.3254 \text{ radians} \\ &= 18.6441^\circ \end{aligned}$$

And $\omega = 5030 \left(\frac{2\pi}{60} \right) = 526.7404 \text{ rad/sec}$. Hence from (1)

$$\begin{aligned}\omega_{CB} &= \frac{(2.1) (526.7404) \sin \left(28 \frac{\pi}{180} \right)}{(5.8) \cos (0.3254)} \\ &= 94.495 \text{ rad/sec}\end{aligned}$$

In vector form

$$\vec{\omega}_{CB} = 94.495 \hat{k}$$

Now we draw the acceleration vectors and resolve them

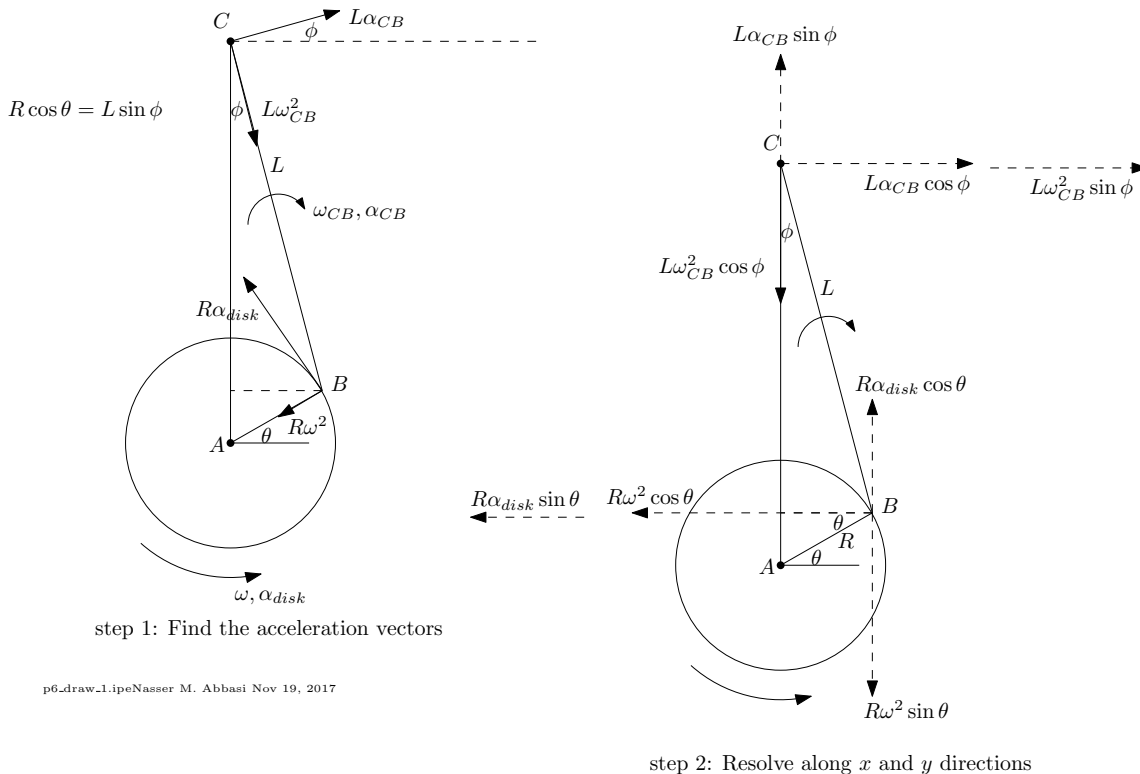

The x component of the acceleration of point C is zero. Hence from the diagram

$$L\alpha_{CB} \cos \phi + L\omega_{CB}^2 \sin \phi - R\alpha_{disk} \sin \theta - R\omega^2 \cos \theta = 0$$

Solving for α_{CB}

$$\alpha_{CB} = \frac{R\alpha_{disk} \sin \theta + R\omega^2 \cos \theta - L\omega_{CB}^2 \sin \phi}{L \cos \phi}$$

Since $\alpha_{disk} = 0$ since we are told ω is constant, then the above simplifies to

$$\alpha_{CB} = \frac{R\omega^2 \cos \theta - L\omega_{CB}^2 \sin \phi}{L \cos \phi}$$

Using numerical values gives

$$\begin{aligned}\alpha_{CB} &= \frac{(2.1) (526.7404)^2 \cos \left(28 \frac{\pi}{180} \right) - (5.8) (94.49471)^2 \sin (0.3254)}{(5.8) \cos (0.3254)} \\ &= 90598.94 \text{ rad/sec}^2\end{aligned}$$

In vector form

$$\vec{\alpha}_{CB} = -90598.94 \hat{k}$$

The acceleration of point C is only in vertical direction. From diagram

$$\begin{aligned}a_{C,y} &= L\alpha_{CB} \sin \phi - L\omega_{CB}^2 \cos \phi - R\omega^2 \sin \theta \\ &= (5.8) (90598.95) \sin (0.3254) - (5.8) (94.495)^2 \cos (0.3254) - (2.1) (526.7404)^2 \sin \left(28 \frac{\pi}{180} \right) \\ &= -154624.9 \text{ in/sec}^2 \\ &= -12885.41 \text{ ft/sec}^2\end{aligned}$$

Hence in vector form

$$\vec{a}_C = -12885.37\hat{j} \text{ ft/sec}^2$$

6.11 HW 11

6.11.1 Problem 1

The uniform slender bar AB has a weight $W_{AB} = 128$ lb while the crate's weight is $W_C = 462$ lb. The bar AB is rigidly attached to the cage containing the crate. Neglect the mass of the cage, and assume that the mass of the crate is uniformly distributed. Furthermore, let $L = 8.8$ ft, $d = 2.6$ ft, $h = 3.9$ ft, and $w = 6.3$ ft. If the trolley is accelerating with $a_0 = 9 \text{ ft/s}^2$, determine θ so that the bar-crate system translates with the trolley.

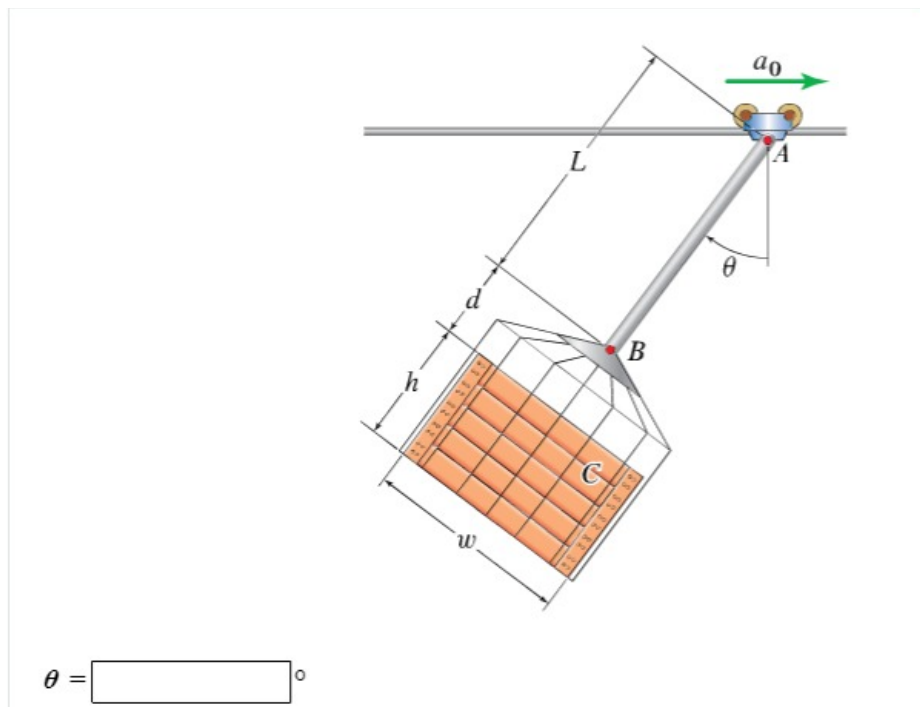

Let us assume the center of mass of the overall system is at some distance z from point A somewhere between A and C . It does not matter where it is. Therefore the rotational equation of motion for the hanging system is

$$M_{cg} = I_A \alpha$$

Where M is the moment of external forces around this center of mass and I_A is the mass moment of inertia around A . But since we want the system to be translating, then $\alpha = 0$. Therefore

$$M = 0$$

$$F_y z \sin \theta - F_x z \cos \theta = 0 \quad (1)$$

Notice the weights do not come into play, since we are taking moments about center of mass of the overall system.

So we just need to find F_x, F_y . These forces are the reactions on point A where it is connected. These can be found by resolving forces in the horizontal and vertical direction. In horizontal direction

$$F_x = (m_{AB} + m_C) a_0 \quad (2)$$

In vertical direction (where there is no acceleration)

$$F_y - W_{AB} - W_C = 0$$

$$F_y = W_{AB} + W_C \quad (3)$$

Plugging (2,3) into (1) and canceling z (as we see, we really did not need to find where z is), gives

$$(W_{AB} + W_C) \sin \theta - (m_{AB} + m_C) a_0 \cos \theta = 0$$

$$\tan \theta = \frac{(m_{AB} + m_C) a_0}{(W_{AB} + W_C)}$$

Plugging the numerical values

$$\tan \theta = \frac{\left(\frac{128}{32.2} + \frac{462}{32.2}\right) 9}{(128 + 462)}$$

$$= 0.279$$

Hence

$$\theta = \arctan(0.279)$$

$$= 0.272$$

$$= 15.616^\circ$$

6.11.2 Problem 2

A person is pushing a lawn mower of mass $m = 37 \text{ kg}$ and with $h = 0.71 \text{ m}$, $d = 0.22 \text{ m}$, $\ell_A = 0.29 \text{ m}$, and $\ell_B = 0.35 \text{ m}$. Assuming that the force exerted on the lawn mower by the person is completely horizontal, the mass center of the lawn mower is G , and neglecting the rotational inertia of the wheels, determine the minimum value of this force that causes the rear wheels (labeled A) to lift off the ground. In addition, determine the corresponding acceleration of the mower.

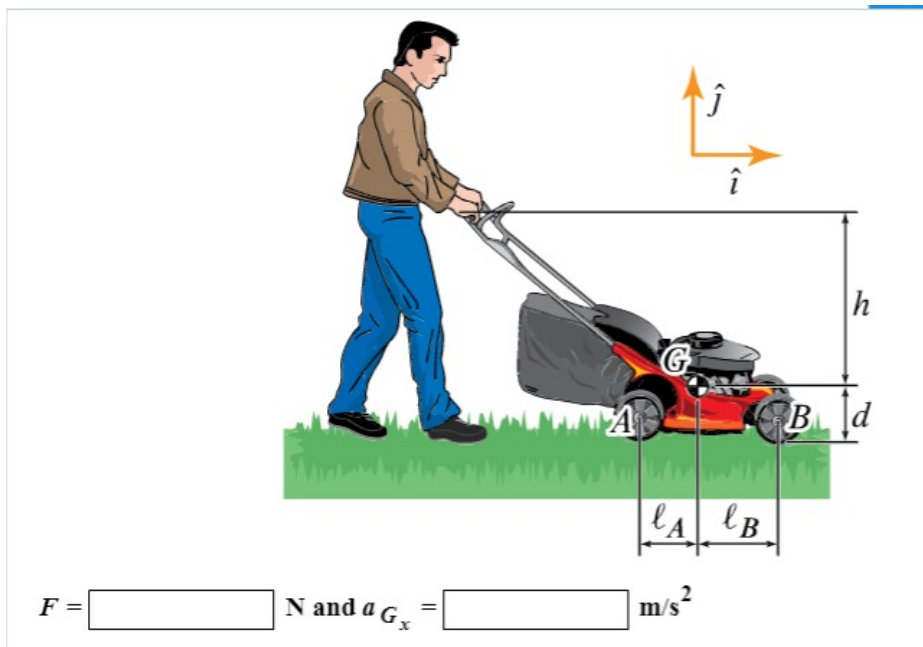

Taking moments about G (and assuming no friction from the ground as problems says to neglect rotational inertia of wheels, which seems to imply this).

$$-Fh + N_B L_B - N_A L_A = I \alpha$$

For $\alpha = 0$

$$-Fh + N_B L_B - N_A L_A = 0$$

And when $N_A = 0$

$$F = \frac{N_B L_B}{h}$$

But $N_A + N_B = mg$ or since $N_A = 0$ then $N_B = mg$ and the above becomes

$$\begin{aligned} F_{\min} &= \frac{mgL_B}{h} \\ &= \frac{(37)(9.81)(0.35)}{(0.71)} \\ &= 178.929 \text{ N} \end{aligned}$$

And the acceleration is

$$\begin{aligned} F &= ma \\ 178.929 &= 37a \\ a &= \frac{178.929}{37} \\ &= 4.836 \text{ m/s}^2 \end{aligned}$$

6.11.3 Problem 3

A conveyor belt must accelerate the cans from rest to $v = 18.2 \text{ ft/s}$ as quickly as possible. Treating each can as a uniform circular cylinder weighing 1.4 lb , find the minimum possible time to reach v so that the cans do not tip or slip on the conveyor. Assume that acceleration is uniform and use $w = 4.9 \text{ in.}$, $h = 5.1 \text{ in.}$, and $\mu_s = 0.51$.

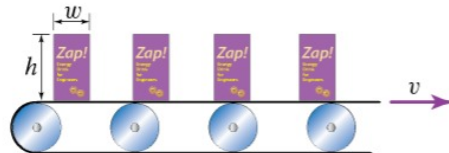

$$t_{\min} = \boxed{} \text{ s}$$

$$\begin{aligned} F &= ma \\ \mu N &= ma \\ a &= \frac{\mu N}{m} \\ &= \frac{(0.51)(mg)}{m} \\ &= (0.51)(32.2) \\ &= 16.422 \text{ ft/s}^2 \end{aligned}$$

Hence

$$\begin{aligned} v &= at \\ t &= \frac{v}{a} \\ &= \frac{18.2}{16.422} \\ &= 1.108 \text{ sec} \end{aligned}$$

6.11.4 Problem 4

The spool is pinned at its center at O , about which it can spin freely. The radius of the spool is $R = 0.18$ m, its radius of gyration is $k_O = 0.11$ m, and the mass of the spool is $m_S = 4$ kg.

The mass B is suspended from the periphery of the spool by a chain of negligible mass that moves over the spool without slip. The mass of B is $m_B = 6$ kg.

If the system is released from rest, determine the angular acceleration of the spool and the tension in the chain.

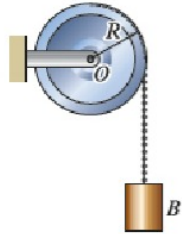

$$T = \boxed{} \text{ N}$$

$$\vec{a}_S = \boxed{} \hat{k} \text{ rad/s}^2$$

Resolve forces in vertical direction for hanging mass

$$T - m_B g = m_B a_y$$

But $a_y = R\alpha$ where α is angular acceleration of spool. Hence

$$T - m_B g = m_B R \alpha \quad (1)$$

For the spool, the equation of motion is $M = I\alpha$ or

$$-TR = mr_G^2 \alpha \quad (2)$$

Where r_G is radius of gyration. We have two equations and two unknowns α, T , solving gives

$$\alpha = \frac{-m_B g R}{mr_G^2 + m_B R^2}$$

$$T = m_B R \alpha + m_B g$$

Hence

$$\alpha = \frac{-(6)(9.81)(0.18)}{(4)(0.11)^2 + (6)(0.18)^2} = -43.636 \text{ rad/sec}^2$$

And

$$T = (6)(0.18)(-43.636) + (6)(9.81)$$

$$= 11.733 \text{ N}$$

6.11.5 Problem 5

The driveway gate is hinged at its right end and can swing freely in the horizontal plane. The gate is pushed open by the force P that always acts perpendicular to the plane of the gate at point A , which is a horizontal distance d from the gate hinge. The weight of the gate is $W = 213$ lb, and its mass center is at G , which is a distance $w/2$ from each end of the gate, where $w = 14$ ft. Assume that the gate is initially at rest and model the gate as a uniform thin bar as shown below in the photo. Given that a force $P = 21$ lb is applied at the center of mass of the gate (i.e., $d = w/2$), determine the reaction at the hinge O after the force P has been continuously applied for 2.2 s.

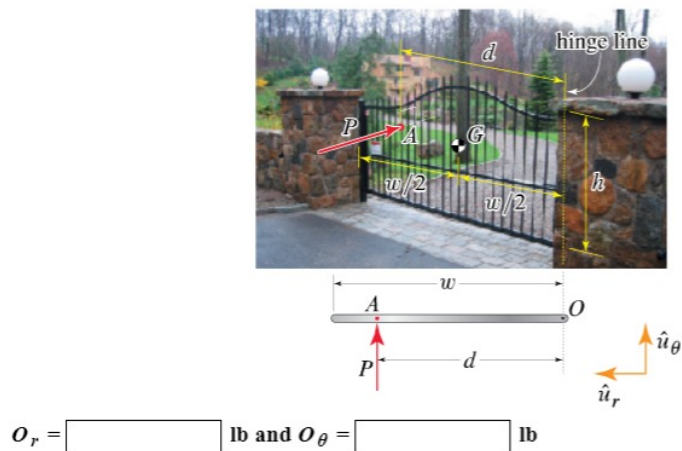

I will use L for w so not to confuse it with ω . Resolving forces in x direction

$$-O_x = ma_{Gx}$$

in the y direction

$$P + O_y = ma_{Gy}$$

But $a_{Gx} = \frac{L}{2}\omega^2$ and $a_{Gy} = -\frac{L}{2}\alpha$ where α is angular acceleration of gate. Hence the above becomes

$$-O_x = m\frac{L}{2}\omega^2 \quad (1)$$

$$P + O_y = -m\frac{L}{2}\alpha \quad (2)$$

Now the angular acceleration equation for the gate is, taking moments around center of mass

$$\begin{aligned} O_y \frac{L}{2} &= I_{cg} \alpha \\ &= \frac{mL^2}{12} \alpha \end{aligned} \quad (3)$$

From (2) $O_y = -m\frac{L}{2}\alpha - P$, plug this in (3) gives

$$\begin{aligned} \left(-m\frac{L}{2}\alpha - P\right) \frac{L}{2} &= \frac{mL^2}{12} \alpha \\ -P \frac{L}{2} &= \frac{mL^2}{12} \alpha + m\frac{L^2}{4} \alpha \\ -P \frac{L}{2} &= \alpha \left(\frac{mL^2}{12} + \frac{mL^2}{4} \right) \\ \alpha &= -\frac{P \frac{L}{2}}{\frac{1}{3}L^2 m} \\ &= -\frac{3}{2} \frac{P}{Lm} \end{aligned}$$

Plug-in numerical values

$$\alpha = -\frac{3}{2} \frac{(21)}{(14) \left(\frac{213}{32.2} \right)} = -0.340$$

From (3)

$$\begin{aligned} O_y &= \frac{mL}{6} \alpha \\ &= \frac{213}{32.2} (14) \\ &= \frac{(-0.3408)}{6} \\ &= -5.25 \text{ N} \end{aligned}$$

To find ω , from $\omega = \alpha t = -0.340 (2.2) = -0.748 \text{ rad/sec}$, hence from (1)

$$\begin{aligned} -O_x &= m \frac{L}{2} \omega^2 \\ &= \frac{213}{32.2} \left(\frac{14}{2} \right) (-0.748)^2 \\ O_x &= -25.929 \text{ N} \end{aligned}$$

6.11.6 Problem 6

The T bar consists of two thin rods, OA and BD , each of length $L = 1.88 \text{ m}$ and mass $m = 10 \text{ kg}$, that are connected to the frictionless pin at O . The rods are welded together at A and lie in the vertical plane. If, at the instant shown, the system is rotating clockwise with angular velocity $\omega_0 = 6.9 \text{ rad/s}$, determine the force on the pin at O as well as the angular acceleration of the rods.

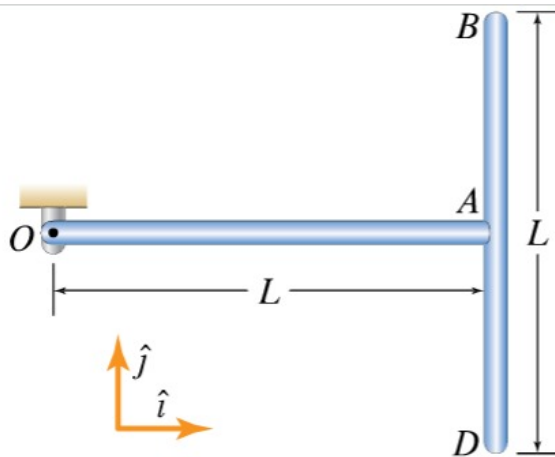

The force on pin O is $(\quad) \hat{i} + (\quad) \hat{j}$ N.

The angular acceleration of the rods is $(\quad) \text{ rad/s}^2 \hat{k}$.

Resolving forces in x direction, where F_x, F_y are forces in hinge

$$F_x = -m \left(\frac{3}{2} L \right) \omega^2 \quad (1)$$

In y direction

$$F_y - 2mg = m \left(\frac{3}{2} L \right) \alpha \quad (2)$$

Taking moments about the hinge O

$$\left(-mg \frac{L}{2} - mgL \right) = \left(\left(m \frac{L^2}{3} \right) + \left(\frac{1}{12} mL^2 + mL^2 \right) \right) \alpha \quad (3)$$

Solving (2,3) for F_y, α gives

$$\begin{aligned} F_y &= 40.394 \text{ N} \\ \alpha &= -5.52503 \text{ rad/sec}^2 \end{aligned}$$

We are given $\omega = 6.9$ rad/sec., hence from (1)

$$F_x = -1342.6 \text{ N}$$

6.12 HW 12

6.12.1 Problem 1

A bowling ball is thrown onto a lane with a backspin ω_0 and forward velocity v_0 . The mass of the ball is m , its radius is r , its radius of gyration is k_G , and the coefficient of kinetic friction between the ball and the lane is μ_k . Assume the mass center G is at the geometric center. For a 15 lb ball with $r = 4.25$ in., $k_G = 2.4$ in., $\omega_0 = 9$ rad/s, and $v_0 = 17$ mph, determine the time it takes for the ball to start rolling without slip and its speed when it does so. In addition, determine the distance it travels before it starts rolling without slip. Use $\mu_k = 0.11$.

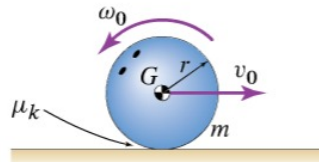

$$t = \boxed{} \text{ s}$$

$$d = \boxed{} \text{ ft}$$

A ball will roll with slip when the linear velocity v of its center of mass is different from $r\omega$ where r is the radius and ω is the spin angular velocity. Therefore, to find when the ball will roll without slipping, we need to find when $v = r\omega$. Let the initial state be such that $v_1 = v_0$ (given) and $\omega_1 = \omega_0$ (given). So we need to find the time t to get to new state, such that $v_2 = r\omega_2$

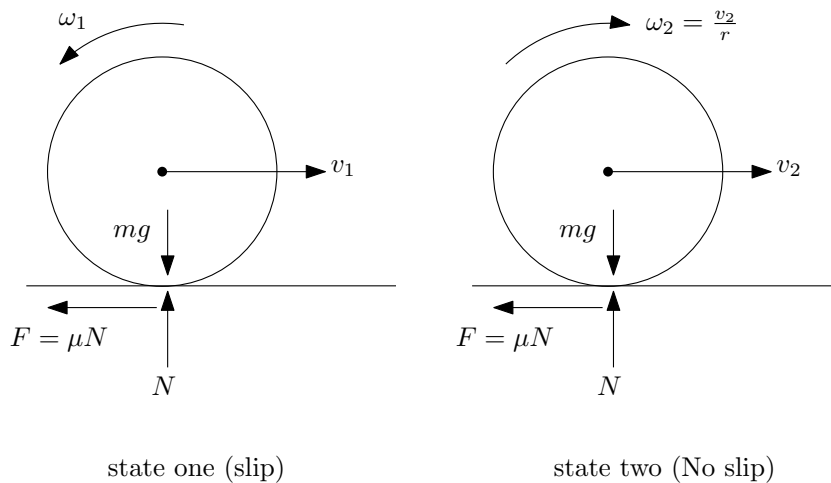

Nasser M Abbasi, Nov 23, 2017. p1_ball.ipe

Using linear momentum

$$mv_1 + \int_0^{t_{final}} F_{friction} dt = mv_2$$

But $F_{friction} = -\mu N = -\mu mg$ and the above becomes

$$mv_1 - \mu mgt = mv_2 \quad (1)$$

Using the angular momentum gives

$$I\omega_1 + \int_0^{t_{final}} F_{friction} r dt = I\omega_2$$

$$mr_G^2 \omega_1 - \mu mgt r = -mr_G^2 \left(\frac{v_2}{r} \right) \quad (2)$$

Where in (2), r_G is radius of gyration, and we replaced ω_2 by $\frac{v_2}{r}$. Notice the sign in RHS of (2) is negative, since we assume v_2 is moving to the right, so in state 2, the ball will be spinning clock wise, which is negative,. Now we have two equations (1,2) with two unknowns t , which is the time to get to the state such that center of mass moves with same speed as $r\omega$ (i.e. no slip) and the second unknown is v_2 which is the speed at which the ball will be rolling at that time. We now solve (1,2) for t, v_2

(1) becomes

$$\left(\frac{15}{32.2}\right)\left(17\left(\frac{5280}{3600}\right)\right) - (0.11)\left(\frac{15}{32.2}\right)(32.2)t = \left(\frac{15}{32.2}\right)v_2 \quad (1A)$$

$$\left(\frac{15}{32.2}\right)\left(\frac{2.4}{12}\right)^2(9) - (0.11)\left(\frac{15}{32.2}\right)(32.2)\left(\frac{4.25}{12}\right)t = -\left(\frac{15}{32.2}\right)\left(\frac{2.4}{12}\right)^2\left(\frac{v_2}{\left(\frac{4.25}{12}\right)}\right) \quad (2A)$$

Or

$$11.615 - 1.65t = 0.466v_2 \quad (1A)$$

$$0.168 - 0.584t = -0.0526v_2 \quad (2A)$$

Solution is:

$$t = 1.9196 \text{ sec}$$

$$v_2 = 18.134 \text{ ft/sec}$$

Now that we know the time and the final velocity, we can find the acceleration of the ball

$$\begin{aligned} v_2 &= v_1 + at \\ a &= \frac{v_2 - v_1}{t} \\ &= \frac{18.134 - 17\left(\frac{5280}{3600}\right)}{1.9196} \\ &= -3.542 \text{ ft/s}^2 \end{aligned}$$

Hence the distance travelled is

$$\begin{aligned} s &= v_0t + \frac{1}{2}at^2 \\ &= 17\left(\frac{5280}{3600}\right)(1.9196) + \frac{1}{2}(-3.542)(1.9196)^2 \\ &= 41.3361 \text{ ft} \end{aligned}$$

6.12.2 Problem 2

A spool of mass $m = 213 \text{ kg}$, inner and outer radii $\rho = 1.74 \text{ m}$ and $R = 2.24 \text{ m}$, respectively, and radius of gyration $k_G = 2 \text{ m}$, is being lowered down an incline with $\theta = 27^\circ$. If the static and kinetic friction coefficients between the incline and the spool are $\mu_s = 0.45$ and $\mu_k = 0.31$, respectively, determine the acceleration of G , the angular acceleration of the spool, and the tension in the cable.

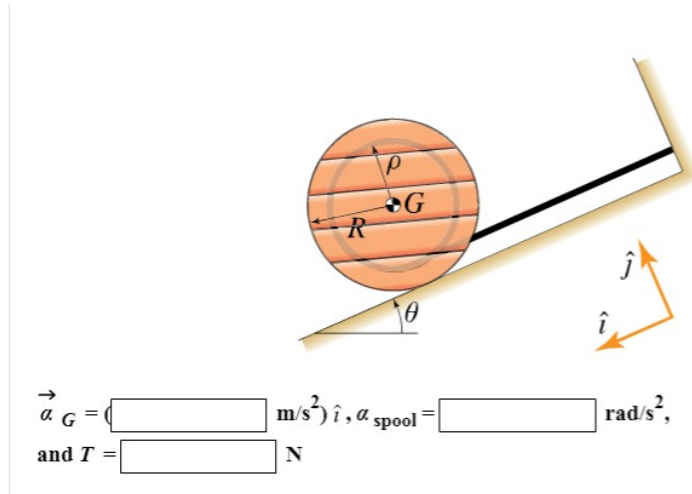

Using the following FBD

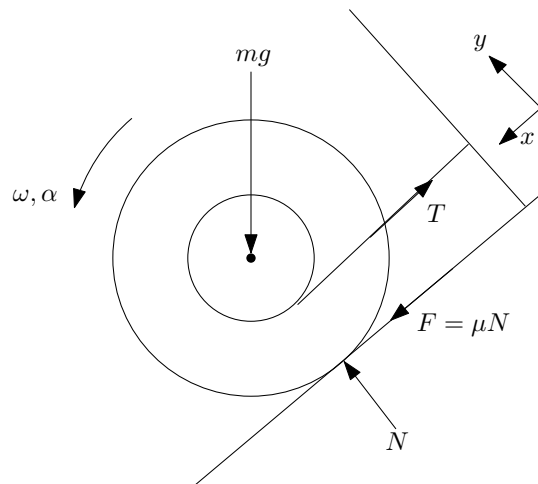

Nasser M Abbasi, Nov 23, 2017. p2.ball.ipe

Notice that the Friction force F is pointing downwards since the spool is spinning counter clockwise. Resolving forces along x gives

$$F - T + mg \sin \theta = m\ddot{x} \quad (1)$$

Taking moment about CG, using clockwise as positive now, since we changed x positive direction from normal

$$FR - T\rho = I_{cg}\alpha \quad (2)$$

Where α is angular acceleration of spool. But $\ddot{x} = -\rho\alpha$ then (1) becomes

$$F - T + mg \sin \theta = -m\rho\alpha \quad (3)$$

But

$$\begin{aligned} F &= \mu_k N \\ &= \mu_k mg \cos \theta \end{aligned}$$

Therefore (2) and (3) become

$$\mu_k mg \cos \theta R - T\rho = I_{cg}\alpha \quad (2A)$$

$$\mu_k mg \cos \theta - T + mg \sin \theta = -m\rho\alpha \quad (3A)$$

In (2A) and (3A) there are 2 unknowns, α and T . Plugging numerical values gives

$$(0.31)(213)(9.81) \cos\left(27\left(\frac{\pi}{180}\right)\right)(2.24) - T(1.74) = (213)(2)^2 \alpha$$

$$(0.31)(213)(9.81) \cos\left(27\left(\frac{\pi}{180}\right)\right) - T + (213)(9.81) \sin\left(27\left(\frac{\pi}{180}\right)\right) = -(213)(1.74) \alpha$$

Or

$$1292.823 - 1.74T = 852.0\alpha \quad (2A)$$

$$1525.78 - 1.0T = -370.62\alpha \quad (3A)$$

Solution is:

$$T = 1188.547 \text{ N}$$

$$\alpha = -0.9099 \text{ rad/s}^2$$

Now since $\ddot{x} = -\rho\alpha$ then

$$\ddot{x} = -(1.74)(-0.9099)$$

$$= 1.583 \text{ m/s}^2$$

6.12.3 Problem 3

The uniform ball of radius ρ and mass m is gently placed in the bowl B with inner radius R and is released. The angle ϕ measures the position of the center of the ball at G with respect to a vertical line, and the angle θ measures the rotation of the ball with respect to a vertical line. Assume that the system lies in the vertical plane. Assuming that the ball rolls without slip that it weighs 2.9 lb, is at the position $\phi = 40^\circ$, and is moving clockwise at 9.1 ft/s, determine the acceleration of the center of the ball \mathbf{a}_G and the normal and friction force between the ball and the bowl. Use $R = 4.2$ ft and $\rho = 1.2$ ft. *Hint:* In working the following problem, we recommend using the ϕ coordinate system shown.

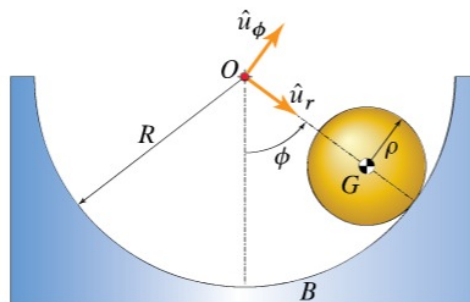

$$\vec{a}_G = (\text{ } \text{ft/s}^2) \hat{u}_r + (\text{ } \text{ft/s}^2) \hat{u}_\phi$$

$$N = \text{ } \text{lb (magnitude)}$$

$$F = \text{ } \text{lb (magnitude)}$$

The forces in play are

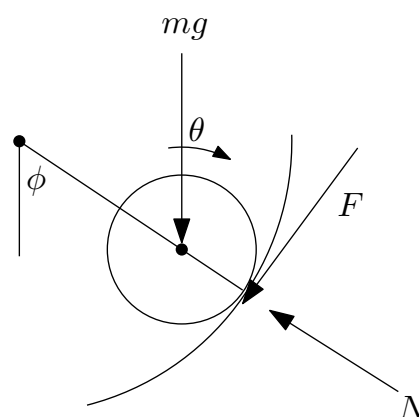

Resolving forces along \hat{u}_ϕ

$$-F - mg \sin \phi = m(R - \rho) \ddot{\phi} \quad (1)$$

Taking moment around C.G. of ball

$$-F\rho = I_{cg} \ddot{\theta} \quad (2)$$

The above are 2 equations in 3 unknowns ($F, \ddot{\theta}, \ddot{\phi}$). So we need one more equation. Resolving along \hat{u}_r will not give us an equation in any of these unknowns so it will not be useful for this. Here we must notice that acceleration of point D , where the ball touches the bottom of the bowl will be zero. This is because the ball rolls without slip. We can use this to come up with the third equation. The acceleration of this point in the \hat{u}_ϕ direction is zero, and given by

$$a_{D,\phi} = (R - \rho) \ddot{\phi} + \rho \ddot{\theta} = 0 \quad (3)$$

Now we have three equations with three unknowns. Plug-in numerical values, using $I_{cg} = \frac{2}{5}m\rho^2$

$$-F - (2.9) \sin\left(40\left(\frac{\pi}{180}\right)\right) = \left(\frac{2.9}{32.2}\right)(4.2 - 1.2) \ddot{\phi} \quad (1A)$$

$$-F(1.2) = \left(\frac{2}{5}\left(\frac{2.9}{32.2}\right)(1.2^2)\right) \ddot{\theta} \quad (2A)$$

$$0 = (4.2 - 1.2) \ddot{\phi} + (1.2) \ddot{\theta} \quad (3A)$$

Or

$$-F - 1.864 = 0.27 \ddot{\phi} \quad (1A)$$

$$-1.2F = 0.0519 \ddot{\theta} \quad (2A)$$

$$0 = 1.2 \ddot{\theta} + 3 \ddot{\phi} \quad (3A)$$

Solving gives

$$F = -0.5326 \text{ N}$$

$$\ddot{\theta} = 12.32 \text{ rad/s}^2$$

$$\ddot{\phi} = -4.928 \text{ rad/s}^2$$

To find N , we resolve forces along \hat{u}_r

$$-N + mg \cos \phi = -m(R - \rho) \dot{\theta}^2$$

But $\dot{\theta} = \frac{v}{(R-\rho)}$, where $v = 9 \text{ ft/sec}$ in this problem. Hence the above becomes

$$-N + mg \cos \phi = -m \left(\frac{v^2}{R - \rho} \right)$$

$$N = mg \cos \phi + m \left(\frac{v^2}{R - \rho} \right)$$

$$= (2.9) \cos\left(40\frac{\pi}{180}\right) + \frac{2.9}{32.2} \left(\frac{(9.1)^2}{(4.2 - 1.2)} \right)$$

$$= 4.708 \text{ N}$$

Now to find \vec{a}_G . Since

$$\vec{a}_G = (R - \rho) \ddot{\phi} \hat{u}_\phi - \frac{v^2}{R - \rho} \hat{u}_r$$

Then

$$\begin{aligned} \vec{a}_G &= -(4.1 - 1.2) 4.928 \hat{u}_\phi - \frac{(9.1)^2}{(4.2 - 1.2)} \hat{u}_r \\ &= -14.291 \hat{u}_\phi - 27.603 \hat{u}_r \end{aligned}$$

6.12.4 Problem 4

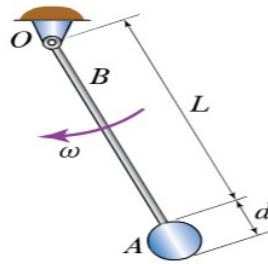

A pendulum consists of a uniform disk A of diameter $d = 0.16$ m and mass $m_A = 0.37$ kg attached at the end of a uniform bar AB of length $L = 0.75$ m and mass $m_B = 0.7$ kg. At the instant shown, the pendulum is swinging with an angular velocity $\omega = 0.23$ rad/s clockwise.

Determine the kinetic energy of the pendulum at this instant, using $T = \frac{1}{2} m v_G^2 + \frac{1}{2} I_G \omega^2$.

$$T = \boxed{} \text{ J}$$

Let r be radius of disk. Then, about joint O at top,

$$\begin{aligned} I_{disk} &= m_{disk} \frac{r^2}{2} + m_{disk} (L + r)^2 \\ &= (0.37) \frac{(0.08)^2}{2} + 0.37 (0.75 + 0.08)^2 \\ &= 0.256077 \end{aligned}$$

And

$$\begin{aligned} I_{bar} &= m_{bar} \frac{L^2}{3} \\ &= (0.7) \frac{(0.75)^2}{3} \\ &= 0.131 \end{aligned}$$

Hence overall

$$\begin{aligned} I_o &= I_{disk} + I_{bar} \\ &= 0.256 + 0.131 \\ &= 0.387 \end{aligned}$$

Therefore

$$\begin{aligned} KE &= \frac{1}{2} I_o \omega^2 \\ &= \frac{1}{2} (0.387) (0.23)^2 \\ &= 0.01024 \text{ J} \end{aligned}$$

6.12.5 Problem 5

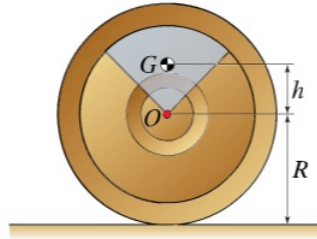

An eccentric wheel with weight $W = 260$ lb, mass center G , and radius of gyration $k_G = 1.32$ ft is initially at rest in the position shown. Letting $R = 1.76$ ft and $h = 0.6$ ft, and assuming that the wheel is gently nudged to the right and rolls without slip, determine the speed of O when G is closest to the ground.

$v_O =$ ft/s

Since wheel rolls without slip, then friction on the ground against the wheel does no work. Therefore we can use work-energy to find v_{final} since we do not need to find friction force and this gives us one equation with one unknown to solve for.

$$\begin{aligned} T_1 + U_1 &= T_2 + U_2 \\ 0 + mgh &= \frac{1}{2}mv_{cg}^2 + \frac{1}{2}I_{cg}\omega^2 - mgh \end{aligned} \quad (1)$$

Where in the above, the datum is taken as horizontal line passing through the middle of the wheel. But

$$I_{cg} = mr_G^2$$

Where r_G is radius of gyration. And

$$v_{cg} = v_o \frac{(R-h)}{R}$$

And $\omega = \frac{v_o}{R}$ since rolls with no slip. Now we have all the terms needed to evaluate (1) and solve for v_o . Here

$$m = \frac{260}{32.2} = 8.075 \text{ slug}$$

Hence (1)

$$\begin{aligned} mgh &= \frac{1}{2}m \left(v_o \frac{(R-h)}{R} \right)^2 + \frac{1}{2}mr_G^2 \left(\frac{v_o}{R} \right)^2 - mgh \\ 260(0.6) &= \frac{1}{2} \left(\frac{260}{32.2} \right) \left(v_o \frac{(1.76-0.6)}{1.76} \right)^2 + \frac{1}{2} \left(\frac{260}{32.2} \right) (1.32)^2 \left(\frac{v_o}{1.76} \right)^2 - 260(0.6) \\ 156 &= 4.025v_o^2 - 156 \end{aligned}$$

Therefore

$$v_o = 8.805 \text{ ft/s}$$

Where the positive root is used since it is moving to the right.

6.12.6 Problem 6

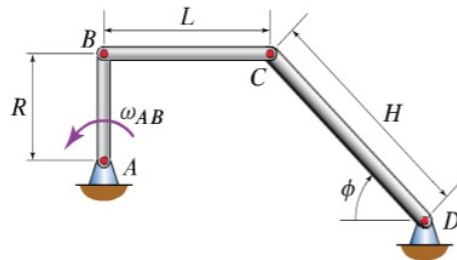

The weights of the uniform thin pin-connected bars AB , BC , and CD are $W_{AB} = 3$ lb, $W_{BC} = 6.5$ lb, and $W_{CD} = 11$ lb, respectively. Letting $\phi = 49^\circ$, $R = 4$ ft, $L = 5.5$ ft, and $H = 6.5$ ft, and knowing that bar AB rotates at an angular velocity $\omega_{AB} = 3$ rad/s, compute the kinetic energy T of the system at the instant shown.

$T = \boxed{} \text{ ft} \cdot \text{lb}$

The velocities at each point are given by

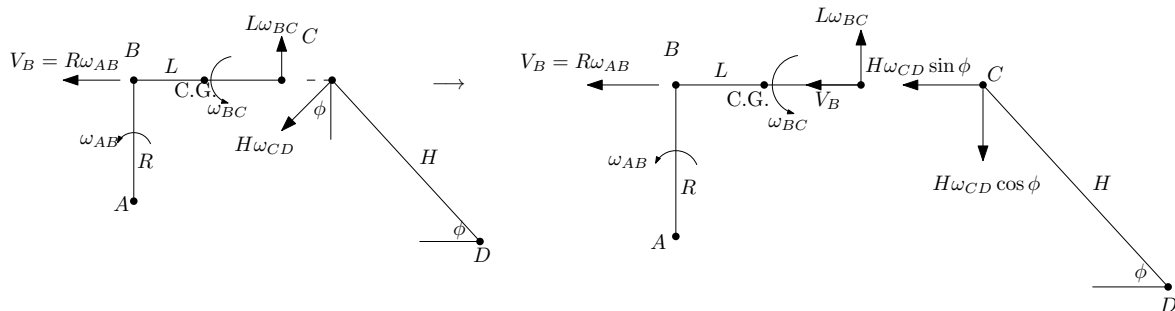

$$\begin{aligned} V_B &= R\omega_{AB} \\ &= 4(3) \\ &= 12 \text{ ft/s} \end{aligned}$$

Looking at point C , we obtain two equations

$$\begin{aligned} L\omega_{BC} &= -H\omega_{CD} \cos \phi \\ -V_B &= -H\omega_{CD} \sin \phi \end{aligned}$$

Or

$$\begin{aligned} (5.5)\omega_{BC} &= -(6.5)\omega_{CD} \cos\left(49\left(\frac{\pi}{180}\right)\right) \\ -12 &= -(6.5)\omega_{CD} \sin\left(49\left(\frac{\pi}{180}\right)\right) \end{aligned}$$

Solving gives

$$\begin{aligned} \omega_{BC} &= -1.897 \text{ rad/sec} \\ \omega_{CD} &= 2.446 \text{ rad/sec} \end{aligned}$$

We now need to find velocity of center of mass of bar BC . We see from diagram that it is given by

$$\begin{aligned} \vec{v}_{CG} &= -V_B \hat{i} - \frac{L}{2} \omega_{BC} \hat{j} \\ &= -12 \hat{i} - \frac{5.5}{2} (-1.897) \hat{j} \\ &= -12 \hat{i} + 5.217 \hat{j} \end{aligned}$$

Hence

$$\begin{aligned} |\vec{v}_{CG}| &= \sqrt{12^2 + 5.217^2} \\ &= 13.085 \text{ ft/sec} \end{aligned}$$

Now we have all the velocities needed. The K.E. of bar AB is

$$\begin{aligned} T_{AB} &= \frac{1}{2} I_{AB} \frac{1}{2} \omega_{AB}^2 \\ &= \frac{1}{2} \left(\frac{1}{3} m_{AB} R^2 \right) \omega_{AB}^2 \\ &= \frac{1}{2} \left(\frac{1}{3} \left(\frac{3}{32.2} \right) (4)^2 \right) (3)^2 \\ &= 2.236 \end{aligned}$$

For bar BC it has both translation and rotation KE

$$\begin{aligned} T_{BC} &= \frac{1}{2} I_{BC} \frac{1}{2} \omega_{BC}^2 + \frac{1}{2} m_{BC} v_{CG}^2 \\ &= \frac{1}{2} \left(\frac{1}{12} m_{BC} L^2 \right) \omega_{BC}^2 + \frac{1}{2} m_{BC} v_{CG}^2 \\ &= \frac{1}{2} \left(\frac{1}{12} \left(\frac{6.5}{32.2} \right) (5.5)^2 \right) (-1.897)^2 + \frac{1}{2} \left(\frac{6.5}{32.2} \right) (13.085)^2 \\ &= 18.197 \end{aligned}$$

And for bar CD it has only rotation KE

$$\begin{aligned} T_{CD} &= \frac{1}{2} I_{CD} \frac{1}{2} \omega_{CD}^2 \\ &= \frac{1}{2} \left(\frac{1}{3} m_{CD} H^2 \right) \omega_{CD}^2 \\ &= \frac{1}{2} \left(\frac{1}{3} \left(\frac{11}{32.2} \right) (6.5)^2 \right) (2.446)^2 \\ &= 14.392 \end{aligned}$$

Therefore the total KE is

$$\begin{aligned} KE &= T_{AB} + T_{BC} + T_{CD} \\ &= 2.236 + 18.197 + 14.392 \\ &= 34.825 \text{ J} \end{aligned}$$

6.13 HW 13

6.13.1 Problem 1

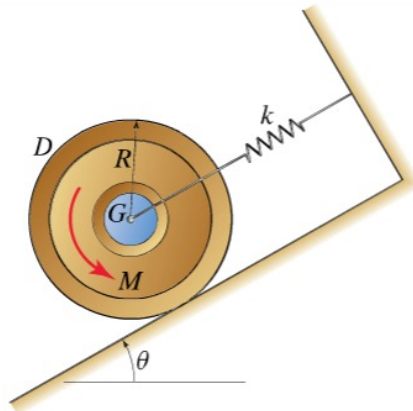

The disk D , which has weight W , mass center G coinciding with the disk's geometric center, and radius of gyration k_G , is at rest on an incline when the constant moment M is applied to it. The disk is attached at its center to a wall by a linear elastic spring of constant k . The spring is unstretched when the system is at rest. Assuming that the disk rolls without slipping and that it has not yet come to a stop, determine the angular velocity of the disk after its center G has moved a distance d down the incline. After doing so, using $k = 4$ lb/ft, $R = 1.4$ ft, $W = 10$ lb, and $\theta = 28^\circ$, determine the value of the moment M for the disk to stop after rolling $d_s = 4$ ft down the incline.

- $\omega_d =$ A. $\sqrt{\frac{g}{W(R^2 + k_G^2)}} \sqrt{d[(M/R) + W\sin\theta - dk]}$
- B. $\sqrt{\frac{g}{W(R^2 + k_G^2)}} \sqrt{d[(2M/R) + 2W\sin\theta - dk]}$
- C. $\sqrt{\frac{g}{W(R^2 + k_G^2)}} \sqrt{d[(2M/R) + 2W\cos\theta + dk]}$
- D. $\sqrt{\frac{2g}{W(R^2 - k_G^2)}} \sqrt{d[(2M/R) + 2W\sin\theta - dk]}$
- $M =$ ft · lb

Free body diagram is

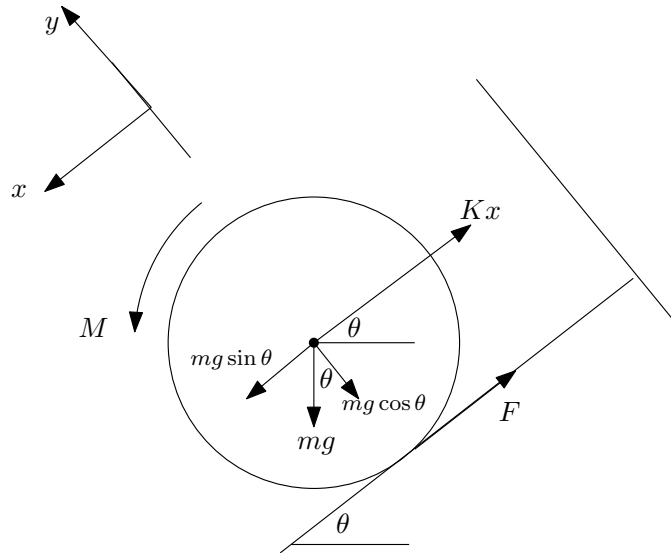

Method one, using work-energy

Applying work energy

$$T_1 + U_1 + \int_0^{\theta_{final}} M d\theta = T_2 + U_2 \quad (1)$$

But $T_1 = 0$ and $U_1 = 0$ (using initial position as datum).

$$\int_0^{\theta_{final}} M d\theta = M\theta_{final} = M\frac{d}{R}$$

Where d is distance travelled (since no slip, we use $d = R\theta$).

$$\begin{aligned} T_2 &= \frac{1}{2}mv_{cg}^2 + \frac{1}{2}I_{cg}\omega^2 \\ &= \frac{1}{2}m(R\omega)^2 + \frac{1}{2}(mk_G^2)\omega^2 \end{aligned}$$

And

$$U_2 = \frac{1}{2}kd^2 - Wd \sin \theta$$

Hence (1) becomes

$$\begin{aligned} M\frac{d}{R} &= \frac{1}{2}m(R\omega)^2 + \frac{1}{2}(mk_G^2)\omega^2 + \frac{1}{2}kd^2 - Wd \sin \theta \\ M\frac{d}{R} - \frac{1}{2}kd^2 + Wd \sin \theta &= \omega^2 \left(\frac{1}{2}mR^2 + \frac{1}{2}mk_G^2 \right) \\ \omega^2 &= \frac{M\frac{d}{R} - \frac{1}{2}kd^2 + Wd \sin \theta}{\frac{1}{2}mR^2 + \frac{1}{2}mk_G^2} \\ &= \frac{2 \left(M\frac{d}{R} - \frac{1}{2}kd^2 + Wd \sin \theta \right)}{\frac{W}{g} (R^2 + k_G^2)} \\ &= \frac{g}{W(R^2 + k_G^2)} \left(2M\frac{d}{R} - kd^2 + 2Wd \sin \theta \right) \end{aligned}$$

Or

$$\omega = \sqrt{\frac{g}{W(R^2 + k_G^2)}} \sqrt{d \left(2\frac{M}{R} + 2W \sin \theta - kd \right)} \quad (2)$$

Hence choice B. Plug-in numerical values gives $k = 4, R = 1.4, W = 10, \theta = 28^\circ$, and since

$I_{disk} = \frac{1}{2}mR^2 = mk_G^2$ then $k_G^2 = \frac{R^2}{2} = \frac{1.4^2}{2} = 0.98$, then (2) becomes for $\omega = 0$

$$0 = \sqrt{\frac{32.2}{10(1.4^2 + 0.98)}} \sqrt{(4) \left(2 \frac{M}{1.4} + 2(10) \sin \left(28 \left(\frac{\pi}{180} \right) \right) - (4)(4) \right)}$$

$$0 = 1.047 \sqrt{5.714M - 26.442}$$

Solving for moment M gives

$$M = 4.627 \text{ ft-lb}$$

Method two, using Newton methods

ΣF_x gives (where positive x is as shown in diagram, going down the slope).

$$W \sin \theta - kx - F = m\dot{x} = mR\ddot{\theta} \quad (1)$$

Taking moment about CG of disk. But note that now anti-clock wise is negative and not positive, due to right-hand rule)

$$-M - FR = -I_{cg}\ddot{\theta} \quad (2)$$

From (2) we solve for F and use (1) to find $\ddot{\theta}$. From (2)

$$F = \frac{I_{cg}\ddot{\theta} - M}{R}$$

Plug the above into (1)

$$W \sin \theta - kx - \frac{I_{cg}\ddot{\theta} - M}{R} = mR\ddot{\theta}$$

$$W \sin \theta - kx = mR\ddot{\theta} + \left(\frac{I_{cg}\ddot{\theta} - M}{R} \right)$$

$$W \sin \theta - kx = mR\ddot{\theta} + \frac{I_{cg}\ddot{\theta}}{R} - \frac{M}{R}$$

$$W \sin \theta - kx = \ddot{\theta} \left(mR + \frac{I_{cg}}{R} \right) - \frac{M}{R}$$

$$\frac{M}{R} + mg \sin \theta - kx = \ddot{\theta} \left(mR + \frac{mk_G^2}{R} \right)$$

Hence

$$\ddot{\theta} = \frac{\frac{M}{R} + W \sin \theta - kx}{mR + \frac{mk_G^2}{R}}$$

$$= \frac{M + WR \sin \theta - kRx}{\frac{W}{g} (R^2 + k_G^2)}$$

$$= \frac{g}{W(R^2 + k_G^2)} (M + WR \sin \theta - kRx)$$

The above shows that $\ddot{\theta}$ is not constant. To find ω we need to integrate both sides. Since

$\ddot{\theta} = \frac{d\omega}{dt} = \frac{d\omega}{dx} \frac{dx}{dt} = \frac{d\omega}{dx} R\omega$ then the above can be written as

$$R\omega d\omega = \frac{g}{W(R^2 + k_G^2)} (M + WR \sin \theta - kRx) dx$$

Integrating

$$\frac{R}{2}\omega^2 = \frac{g}{W(R^2 + k_G^2)} \left(Mx + WRx \sin \theta - kR \frac{x^2}{2} \right)$$

When $x = d$, the above becomes

$$\frac{R}{2}\omega^2 = \frac{g}{W(R^2 + k_G^2)} \left(Md + WRd \sin \theta - kR \frac{d^2}{2} \right) \quad (3)$$

Hence

$$\begin{aligned}\omega^2 &= 2 \left(\frac{g}{W(R^2 + k_G^2)} \left(\frac{Md}{R} + Wd \sin \theta - k \frac{d^2}{2} \right) \right) \\ &= \frac{g}{W(R^2 + k_G^2)} d \left(\frac{2M}{R} + 2W \sin \theta - kd \right)\end{aligned}\quad (4)$$

Compare (4) to (2) in first method, we see they are the same.

6.13.2 Problem 2

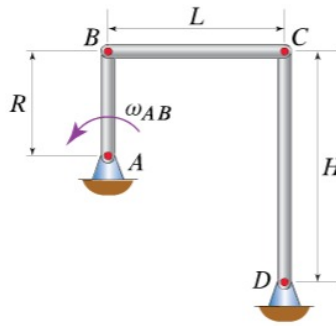

The uniform thin pin-connected bars AB , BC , and CD have masses $m_{AB} = 2.2$ kg, $m_{BC} = 3.4$ kg, and $m_{CD} = 5.2$ kg, respectively. Letting $R = 0.76$ m, $L = 1.2$ m, and $H = 1.54$ m, and knowing that bar AB rotates at a constant angular velocity $\omega_{AB} = 5$ rad/s, compute the angular momentum of bar AB about A , of bar BC about A , and bar CD about D at the instant shown.

$$\begin{aligned}\vec{h}_{(A)AB} &= (\text{ } \text{kg}\cdot\text{m}^2/\text{s}) \hat{k} \begin{matrix} \uparrow j \\ \rightarrow i \end{matrix} \\ \vec{h}_{(A)BC} &= (\text{ } \text{kg}\cdot\text{m}^2/\text{s}) \hat{k} \begin{matrix} \uparrow j \\ \rightarrow i \end{matrix} \\ \vec{h}_{(D)CD} &= (\text{ } \text{kg}\cdot\text{m}^2/\text{s}) \hat{k} \begin{matrix} \uparrow j \\ \rightarrow i \end{matrix}\end{aligned}$$

$$\begin{aligned}h_{AB} &= I_A \omega_{AB} \\ &= \left(\frac{1}{3} m_{AB} R^2 \right) \omega_{AB} \\ &= \frac{1}{3} (2.2) (0.76)^2 (5) \\ &= 2.119 \text{ kg m}^2/\text{s}\end{aligned}$$

For bar BC , it has zero ω_{BC} at this instance. Therefore the only angular momentum comes from translation. Which is

$$h_{BC} = m_{BC} v_{cg} R$$

But v_{cg} for bar BC is $R\omega_{AB}$, hence

$$\begin{aligned}
 h_{BC} &= m_{BC}R^2\omega_{AB} \\
 &= (3.4)(0.76)^2(5) \\
 &= 9.819 \text{ kg m}^2/\text{s}
 \end{aligned}$$

Finally, for bar DC , since its point C moves with speed $v = R\omega_{AB}$, then

$$\begin{aligned}
 R\omega_{AB} &= H\omega_{CD} \\
 \omega_{CD} &= \frac{R}{H}\omega_{AB}
 \end{aligned}$$

Therefore

$$\begin{aligned}
 h_{CD} &= I_{CD}\omega_{CD} \\
 &= \frac{1}{3}m_{CD}H^2\frac{R}{H}\omega_{AB} \\
 &= \frac{1}{3}m_{CD}HR\omega_{AB} \\
 &= \frac{1}{3}(5.2)(1.54)(0.76)(5) \\
 &= 10.143 \text{ kg m}^2/\text{s}
 \end{aligned}$$

6.13.3 Problem 3

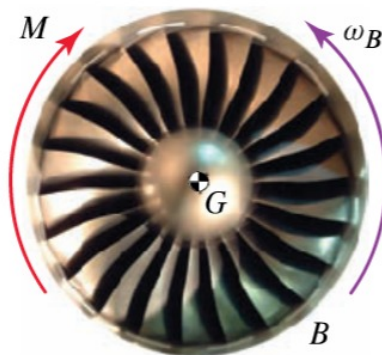

A rotor, B , with center of mass G , weight $W = 3,400$ lb, and radius of gyration $k_G = 15.1$ ft is spinning with an angular speed of $\omega_B = 1,150$ rpm when a braking system is applied to it, providing a time-dependent torque $M = M_0(1 + ct)$, with $M_0 = 3,400$ ft·lb and $c = 0.012 \text{ s}^{-1}$. If G is also the geometric center of the rotor and is a fixed point, determine the time, t_s , that it takes to bring the rotor to a stop.

$$\begin{aligned}
 \text{torque} &= I_{c_g}\ddot{\theta} \\
 -M_0(1 + ct) &= mk_G^2\ddot{\theta} \\
 \frac{d\dot{\theta}}{dt} &= -\frac{M_0}{mk_G^2}(1 + ct) \\
 \int_{\omega_{AB}}^0 d\dot{\theta} &= -\frac{M_0}{mk_G^2} \int_0^{t_s} (1 + ct) dt \\
 -\omega_{AB} &= -\frac{M_0}{mk_G^2} \left(t_s + \frac{c}{2}t_s^2 \right) \\
 \omega_{AB} &= \frac{M_0}{mk_G^2} \left(t_s + \frac{c}{2}t_s^2 \right) \tag{1}
 \end{aligned}$$

Hence

$$(1150) \frac{2\pi}{60} = \frac{3400}{\frac{3400}{32.2} (15.1)^2} \left(t_s + \frac{0.012}{2} t_s^2 \right)$$

$$120.428 = 0.141 \left(t_s + 0.006 t_s^2 \right)$$

Solving

$$t_s = 302.763 \text{ seconds}$$

Another way to solve this is to use conservation of angular momentum.

$$h_1 + \int \tau dt = h_2$$

$$I_{CG} \omega_B + \int_0^{t_s} (-M) dt = 0$$

$$(mk_G^2) \omega_B - \int_0^{t_s} M_0 (1 + ct) dt = 0$$

$$(mk_G^2) \omega_B - M_0 \left(t_s + \frac{c}{2} t_s^2 \right) = 0$$

$$\omega_B = \frac{M_0}{mk_G^2} \left(t_s + \frac{c}{2} t_s^2 \right)$$

Which is the same as (1).

6.13.4 Problem 4

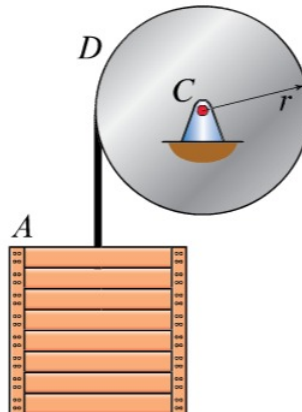

A crate, A , with weight $W_A = 325$ lb is hanging from a rope wound around a uniform drum, D , of radius $r = 1.2$ ft, weight $W_D = 117$ lb, and center C . The systems is initially at rest when the restraining system holding the drum stationary fails, thus causing the drum to rotate, the rope to unwind, and, consequently, the crate to fall. Assuming that the rope does not stretch or slip relative to the drum and neglecting the inertia of the rope, determine the speed of the crate 2.5 s after the system starts to move.

$v =$ ft/s downward

It is easier to solve this using conservation of angular and linear momentum. There are two bodies in this problem. One has angular momentum and the second (cart) has linear momentum. So we need to apply

$$p_1 + \int_0^t f dt = p_1 \quad (1)$$

Where $p = mv$, the linear momentum. The above is applied to the cart. And also apply

$$h_1 + \int_0^t \tau dt = h_1 \quad (2)$$

Where $h = I\omega$, the angular momentum, and this is applied to the drum. Using the above two equations we will find final velocity of cart. We break the system to 2 bodies, using free body diagram. Let tension in cable be T . And since in state (1), $v_A = 0$, then equation (1) becomes

$$\begin{aligned} \int_0^t (T - W_A) dt &= m_A v_A \\ \int_0^t T dt &= W_A t + \frac{W_A}{g} v_A \end{aligned} \quad (3)$$

In the above, $\int_0^t (T - W_A) dt$ is the impulse, and v_A is the final speed we want to find. We do not know the tension T .

Equation (2) becomes ($h_1 = 0$, since drum is not spinning then)

$$\int_0^t Tr dt = I_{cg} \omega_D$$

Where Tr is the torque, caused by the tension T in cable. But $v_A = -r\omega_D$, where the minus sign since it is moving downwards. Hence the above becomes

$$\begin{aligned} \int_0^t T dt &= -\left(\frac{W_D}{g} \frac{r^2}{2}\right) \frac{v_A}{r^2} \\ &= -\left(\frac{W_D}{2g}\right) v_A \end{aligned} \quad (4)$$

Comparing (3,4) we see that

$$\begin{aligned} -\left(\frac{W_D}{2g}\right) v_A &= W_A t + \frac{W_A}{g} v_A \\ W_A t + \frac{W_A}{g} v_A + \left(\frac{W_D}{2g}\right) v_A &= 0 \\ v_A \left(\frac{W_A}{g} + \frac{W_D}{2g}\right) + W_A t &= 0 \\ v_A &= \frac{-2W_A g t}{2W_A + W_D} \end{aligned}$$

Therefore

$$\begin{aligned} v_A &= \frac{-2(325)(32.2)(2.5)}{2(325) + (117)} \\ &= -68.22 \text{ ft/sec} \end{aligned}$$

6.13.5 Problem 5

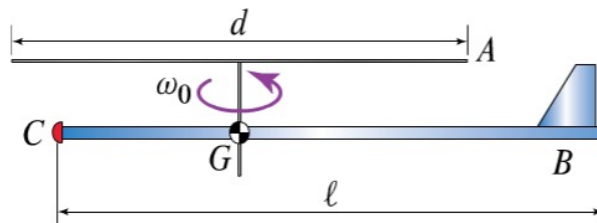

A toy helicopter consists of a rotor, A , with diameter $d = 11.7$ in. and weight $W_A = 0.090 \times 10^{-3}$ oz, a thin body, B , of length $l = 14.3$ in. and weight $W_B = 0.139 \times 10^{-3}$ oz, and a small ballast, C , placed at the front end of the body with weight $W_C = 0.0683 \times 10^{-3}$ oz. The ballast's weight is such that the axis of rotation of the rotor goes through G , which is the center of mass of the body and ballast. While holding the body (and ballast) fixed, the rotor is spun as shown with $\omega_0 = 170$ rpm. Neglecting aerodynamic effects, the weights of the rotor's shaft and the body's tail, and assuming there is friction between the helicopter's body and the rotor's shaft, determine the angular velocity of the body once the toy is released and the angular velocity of the rotor decreases to 45 rpm. Model the body as a uniform thin rod and the ballast as a particle. Assume that the rotor and the body remain horizontal after release.

$$\omega_{Bf} = \boxed{} \text{ rpm}$$

Chapter 7

Quizzes

Local contents

7.1	Quiz 1	248
7.2	Quiz 2	250
7.3	Quiz 3	251
7.4	Quiz 4	252
7.5	Quiz 5	254
7.6	Quiz 6	256
7.7	Quiz 7	258
7.8	Quiz 8	261
7.9	Quiz 9	264
7.10	Quiz 10	266
7.11	Quiz 11	269

7.1 Quiz 1

Score for this attempt: 5 out of 5

Submitted Sep 13 at 7:08pm

This attempt took 12 minutes.

Question 1

2 / 2 pts

A particle is traveling in the x-direction with the acceleration and initial conditions given below.

$$a_x = 20.9 \cos(\pi t) \text{ (m/s}^2\text{) (use radians, not degrees)}$$

The initial velocity is:

$$v_x = 9.4 \text{ m/s}$$

and the initial position is:

$$s_x = 6.0 \text{ m}$$

What is the position in the x-direction in meters after 5 seconds?

Answer to one decimal place.

(hint: be careful with the initial conditions as $\cos(0) = 1$, not 0)

57.2350

Question 2

1 / 1 pts

compute the x-component of the cross product between vectors A and B

$$A = -8i + -9j + 7k$$

$$B = -9i + -8j + 3k$$

29.0000

Question 3

1 / 1 pts

compute the dot product between vectors A and B

$$A = 3i + 0j + -10k$$

$$B = 0i + 7j + -6k$$

Question 4

1 / 1 pts

Compute the angle between vectors A and B in degrees

$$A = 5i + 6j$$

$$B = -3i + 4j$$

7.2 Quizz 2

Question 1

2.5 / 2.5 pts

A particle undergoing rectilinear motion has an acceleration of

$$a = 2.1t^2 \text{ (m/s}^2\text{)}$$

Given

$$v(t=2\text{sec}) = 8.8 \text{ (m/s)} \text{ and } s(t=2\text{sec}) = 13.5 \text{ (m)}$$

Find the position s in meters at $t=5$ seconds

Question 2

2.5 / 2.5 pts

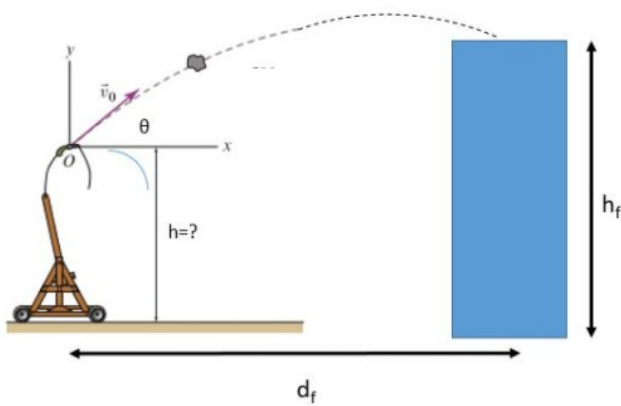

A 2kg rock is being thrown from a catapult to the top of a building. The building is $h_f = 3.0$ meters tall and $d_f = 5.7$ meters from the catapult. Given that the rock is launched with an initial velocity of $v_0 = 8.2$ (m/s) and an angle of $\theta = \frac{\pi}{5}$ radians.

Determine the height of the rock at the moment it is launched from the catapult.

7.3 Quiz 3

Question 1

3 / 3 pts

The hand on a robotic arm is programmed to travel in a path described by

$$r = 1 - 0.7\cos(2\pi t) \text{ (m)}$$

$$\theta = 0.5 - 0.5\sin(2\pi t) \text{ (radians)}$$

What is the magnitude of the acceleration at the hand when $t = 0.8$ sec?

Question 2

1 / 1 pts

For a point traveling on a circular path in the counter-clockwise direction, how are unit vectors for the normal direction and radial direction related?

- they point in the opposite direction
- they point in same directions
- they are orthogonal

Question 3

1 / 1 pts

For a point traveling on an elliptical path in the counter-clockwise direction. How are the unit vectors in the theta direction and tangential direction related?

- There is no relationship for an elliptical path
- They point in the same direction
- They are orthogonal

7.4 Quiz 4

> Question 1 1 pts

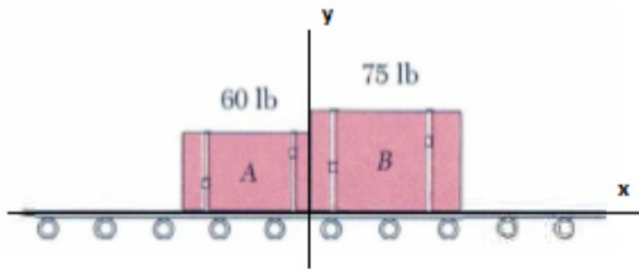

Two packages are placed on a conveyor belt which is at rest as seen in the image above. The packages are initially in contact. The coefficient of kinetic friction is 0.20 between the belt and package A, and 0.1 between the belt and package B. The weights of the packages are shown in the image above.

If the belt suddenly starts moving to the LEFT and slips relative to both packages, what is the acceleration of A in the positive x-direction (in ft/s^2).

Be aware of the sign and units of the answer. Report answers to 2 decimal places.

> Question 2 1 pts

Same situation as the previous question.

If the belt suddenly starts moving to the LEFT and slips relative to both packages, what is the acceleration of B in the positive x-direction (in ft/s^2).

Be aware of the sign and units of the answer. Report answers to 2 decimal places.

> Question 3 1 pts

Same situation as the previous question.

If the belt suddenly starts moving to the RIGHT and slips relative to both packages, what is the acceleration of A in the positive x-direction (in ft/s^2).

Be aware of the sign and units of the answer. Report answers to 2 decimal places.

Question 4 1 pts

Same situation as the previous question.

If the belt suddenly starts moving to the RIGHT and slips relative to both packages, what is the acceleration of B in the positive x-direction (in ft/s^2).

Be aware of the sign and units of the answer. Report answers to 2 decimal places.

Question 5 1 pts

In one of the two scenarios previously described (belt moves left or belt moves right), the packages will stay in contact.

In the scenario where the packages stay in contact, what is the magnitude of the force exerted from one box to the other (in lb)?

Be aware of the sign and units of the answer. Report answers to 2 decimal places.

7.5 Quiz 5

7.5.1 Problems

Question 1 2.5 pts

Estimate the distance between the earth and the sun (don't google the answer. I changed some numbers). Assume that the Earth is on a circular orbit around the sun, which takes 364 days to complete one revolution. Additionally, assume that the sun's position is fixed.

According to Newton's universal gravitational law, the force between the Earth and the Sun is $F = \frac{G m_{\text{sun}} m_{\text{earth}}}{r^2}$

where the universal gravitational constant $G = 6.674 \times 10^{-11} \frac{\text{m}^3}{\text{kg s}^2}$, $m_{\text{sun}} = 1.989 \times 10^{30} \text{ kg}$, $m_{\text{earth}} = 5.972 \times 10^{24} \text{ kg}$, and r is the distance between the earth and the sun.

Calculate the distance r between the earth and sun, and enter your solution for r in **billions of meters**

Question 2 2.5 pts

A 2 kg toy car is driving over rolling hills defined by $y = 8.0 \sin(\pi x)$ meters (use radians for the sine function)

Assuming that the car begins to lose contact with the ground at the top of the hill, what is the velocity of the car at this point?

Calculate the velocity in meters per second and answer to 2 decimal places.

7.5.2 Problem 1 solution

Angular speed of earth around sun is

$$\dot{\theta} = \frac{2\pi}{(364)(24)(60)(60)}$$

Force on earth is therefore $mr\dot{\theta}^2$. Equating this to $F = G \frac{m_e m_s}{r^2}$ and solving for r gives

$$r\dot{\theta}^2 = G \frac{m_s}{r^2}$$

One equation with one unknown r . Solving gives (taking the positive root)

$$r = 149.26 \times 10^9 \text{ meter}$$

7.5.3 Problem 2 solution

$$y(x) = 8 \sin(\pi x)$$

We want to solve for v in

$$\frac{v^2}{\rho} = g$$

But $\rho = \frac{(1+y'(x)^2)^{\frac{3}{2}}}{|y''(x)|}$. To find what x to use, since at top of hill, then we want $\sin(\pi x) = 1$ or $x = \frac{1}{2}$. Plugging this into ρ gives

$$\rho = 0.0126651$$

Hence

$$\frac{v^2}{0.0126651} = 9.81$$

Or

$$v = 0.3525 \text{ m/s}$$

7.6 Quiz 6

7.6.1 Problem 1

Question 1	4 pts
<p>A 30 kg child runs 4.0 m/s and hops onto a sled at the top of a 15.0 meter tall hill. The hill has a 30 degree incline with respect to the horizontal axis, and the kinetic friction coefficient between the sled and the snow is 0.05.</p> <p>Determine the velocity (m/s) of the child at the bottom of the hill. Neglect the mass of the sled.</p>	
<input style="width: 150px; height: 20px;" type="text"/>	

This diagrams shows the setup.

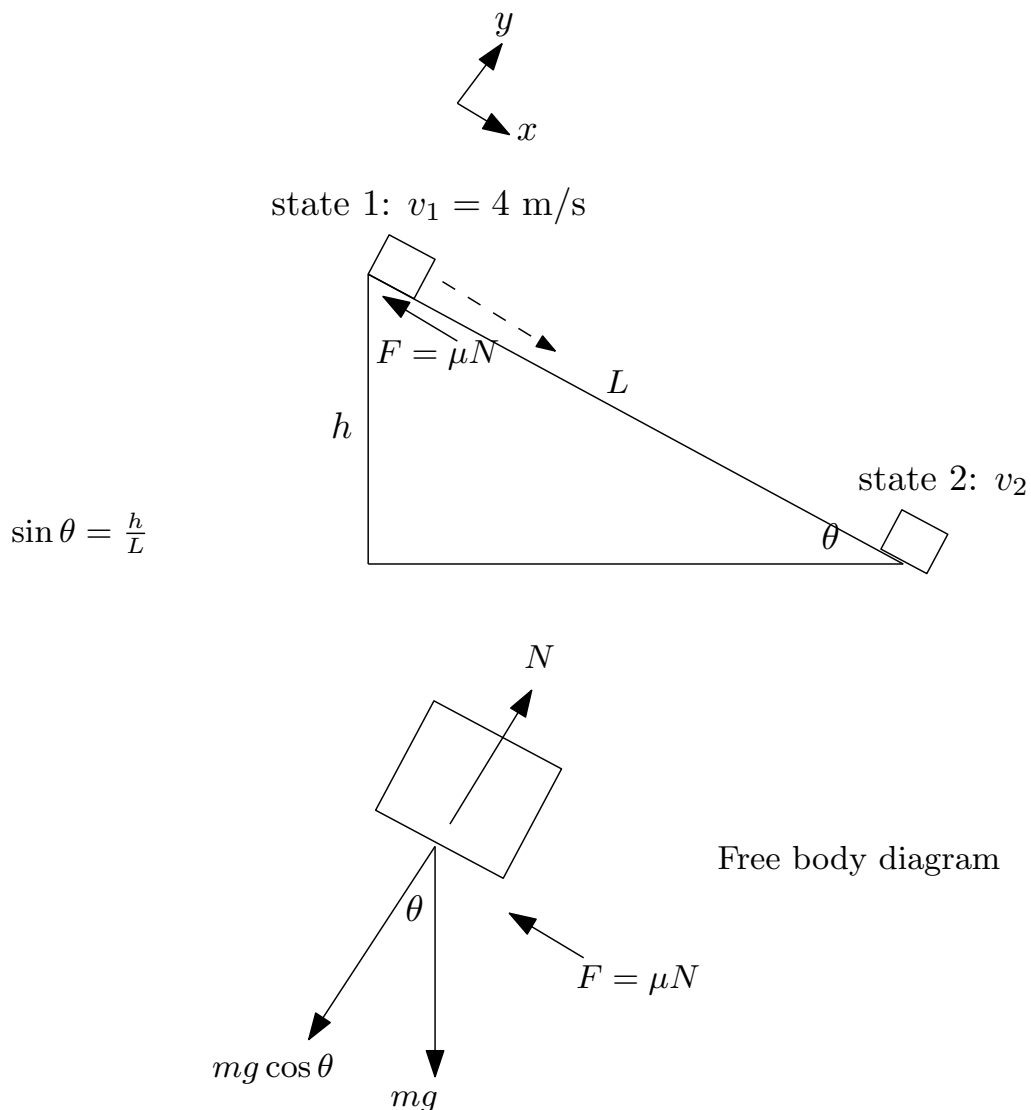

Work-energy is used. There are two states. First state is at the top and the second state is when child reaches the bottom of the hill. Zero datum for gravity potential energy is taken at the bottom of the hill.

We now apply work-energy

$$T_1 + V_1 + U_{12}^{\text{internal}} + U_{12}^{\text{external}} = T_2 + V_2 \quad (1)$$

Where U_{12}^{internal} is work due to internal non-conservative forces. In this case, this is the friction only. And U_{12}^{external} is work due to external applied forces, which is zero in this case,

as there are no external applied forces. Hence

$$U_{12}^{internal} = - \int_0^L F dx$$

Where dx is taken as shown in the diagram. But F which is friction force is $F = \mu N = \mu mg \cos \theta$. Therefore

$$\begin{aligned} U_{12}^{internal} &= - \int_0^L \mu mg \cos \theta dx \\ &= -\mu mg \cos \theta L \end{aligned}$$

But $L = \frac{h}{\sin \theta}$ therefore

$$U_{12}^{internal} = -\mu h m g \frac{\cos \theta}{\sin \theta}$$

Now, $T_1 = \frac{1}{2} m v_1^2$ and $V_1 = mgh$ and $V_2 = 0$ since we assume datum at bottom and $T_2 = \frac{1}{2} m v_2^2$ where v_2 is what we want to solve for. Putting all this in (1) gives

$$\begin{aligned} \frac{1}{2} m v_1^2 + mgh - \mu h m g \frac{\cos \theta}{\sin \theta} &= \frac{1}{2} m v_2^2 \\ v_2^2 &= \frac{2}{m} \left(\frac{1}{2} m v_1^2 + mgh - \mu h m g \frac{\cos \theta}{\sin \theta} \right) \\ v_2 &= \sqrt{v_1^2 + 2gh - 2\mu h g \frac{\cos \theta}{\sin \theta}} \end{aligned} \quad (2)$$

We notice something important here. The velocity at the bottom do not depend on mass m . This is the answer for problem 2. We now just plug-in the numerical values given to find v_2

$$\begin{aligned} v_2 &= \sqrt{4^2 + 2(9.81)(15) - 2(0.05)(15)(9.81) \frac{\cos\left(30\left(\frac{\pi}{180}\right)\right)}{\sin\left(30\left(\frac{\pi}{180}\right)\right)}} \\ &= 16.876 \text{ m/s} \end{aligned}$$

7.6.2 Problem 2

Question 2	1 pts
How would the final velocity of the child change if her mass was doubled?	
<input type="radio"/> No change	
<input type="radio"/> 2 times faster	
<input type="radio"/> 4 times faster	
<input type="radio"/> 1/2 as fast	

Velocity at the bottom do not change if the mass doubles. We see from (2) in problem 1 that v_2 do not depend on mass.

7.7 Quiz 7

7.7.1 Problem 1

Question 1	1 pts
<p>The drone hovers for 41 seconds at a height of 40 meters above the ground while taking a picture of a crowd.</p> <p>What is the vertical impulse by the lift force (combined force of the four rotors) during this time (in <u>Newton-seconds</u>)?</p> <p>Report your answer to the nearest whole number</p> <div style="border: 1px solid #ccc; width: 150px; height: 20px; margin: 10px auto;"></div>	

$$\begin{aligned}
 I &= \int_0^t F dt \\
 &= \int_0^t mg dt \\
 &= mgt \\
 &= (1)(9.81)(41) \\
 &= 402.21 \text{ N-s}
 \end{aligned}$$

7.7.2 Problem 2

Question 2	1 pts
<p>A sudden gust of wind propels the drone against the side of a nearby building at 4.48 m/s. Inertial sensors onboard the drone determine that it bounces back from the building with a speed of 1.10 m/s. Assume this event is a direct central impact.</p> <p>What is the coefficient of restitution between the drone and the building during this collision?</p> <p>Report your answer to three decimal places.</p> <div style="border: 1px solid #ccc; width: 150px; height: 20px; margin: 10px auto;"></div>	

$$-e = \frac{V_B^+ - V_A^+}{V_B^- - V_A^-}$$

Where B is the wall. Hence $V_B^+ = V_B^- = 0$ since wall do not move. Therefore

$$\begin{aligned}
 -e &= \frac{-V_A^+}{-V_A^-} \\
 &= \frac{-(-1.10)}{-(+4.48)} \\
 &= \frac{1.10}{-4.48} \\
 &= -0.24554
 \end{aligned}$$

Hence

$$e = 0.24554$$

7.7.3 Problem 3

Question 3	1 pts
<p>Another gust of wind blows the drone against the building a second time. This time, the impact speed is 5.13 m/s and the rebound speed is 1.47 m/s. It collision takes 0.29 seconds to complete.</p> <p>What is the magnitude of the average force applied by the building to the drone during this collision (in Newtons)?</p> <p>Report your answer to one decimal place.</p> <div style="border: 1px solid #ccc; width: 150px; height: 20px; margin: 10px auto;"></div>	

$$mv_A^- + \int_0^{0.29} F_{av} dt = mv_A^+$$

But $m = 1$ then

$$\begin{aligned} \int_0^{0.29} F_{av} dt &= v_A^+ - v_A^- \\ &= -1.47 - 5.13 \\ &= -6.6 \end{aligned}$$

Hence

$$\begin{aligned} F_{av}(0.29) &= -6.6 \\ F_{av} &= -\frac{6.6}{0.29} \\ &= -22.759 \end{aligned}$$

The magnitude is 22.759 N. The negative sign, since force is in negative x direction.

7.7.4 Problem 4

Question 4	1 pts
<p>A third gust of wind blows the drone against the building a third time. This time the impact speed is 6.4 m/s and the rebound speed is 0.12 m/s.</p> <p>What is the magnitude of the energy dissipated in this collision (in Joules)?</p> <p>Report your answer to one decimal place.</p> <div style="border: 1px solid #ccc; width: 150px; height: 20px; margin: 10px auto;"></div>	

Energy lost is

$$\begin{aligned}\Delta &= \frac{1}{2}m(v_A^-)^2 - \frac{1}{2}m(v_A^+)^2 \\ &= \frac{1}{2}(6.4)^2 - \frac{1}{2}(0.12)^2 \\ &= 20.473 \text{ J}\end{aligned}$$

7.7.5 Problem 5

When blown against the building repeatedly, the drone came dangerously close to a nest of peregrine falcons. It therefore drew the attention of the mother falcon, with mass 1.023 kg, circling above. The falcon, diving at 107 m/s straight down, collides with the drone, which is hovering at a stationary position prior to impact. After they collide the falcon becomes entangled with the drone.

What is the post-impact speed of the drone-plus-falcon system (in m/s)?

Report your answer to one decimal place.

Let A be the falcon and B be the drone. Hence

$$\begin{aligned}m_A v_A^- + m_B v_B^- &= (m_A + m_B) v^+ \\ (1.023)(107) + 0 &= (1.023 + 1) v^+ \\ v^+ &= \frac{(1.023)(107)}{2.023} \\ &= 54.108 \text{ m/s}\end{aligned}$$

7.8 Quizz 8

7.8.1 Problem 1

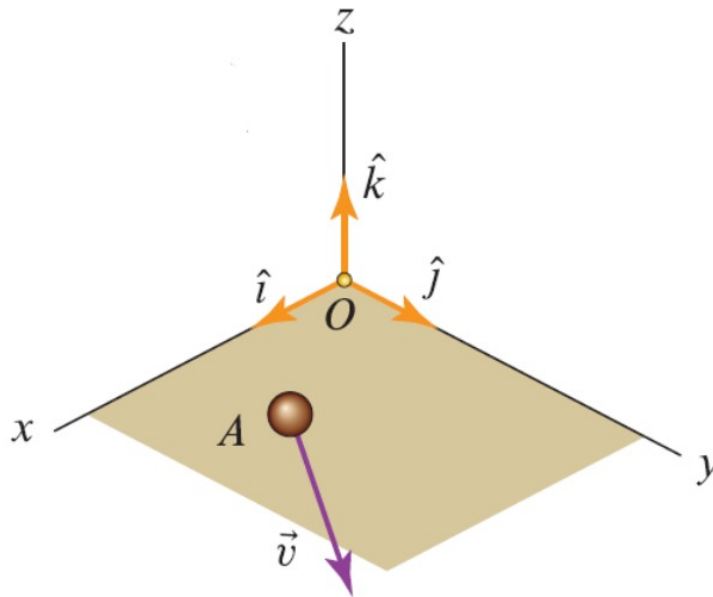

The particle A, which has mass 3 kg, is moving in the coordinate system shown above. A is currently at position $X=1.5$, $Y=5.8$, $Z=-1.2$ m relative to the origin O, and is moving with velocity $\vec{v}=4.1\hat{i}+4.4\hat{j}+5.3\hat{k}$ m/s.

What is the magnitude of the angular momentum of particle A about the origin O ($\text{kg}\cdot\text{m}^2/\text{s}$)?

Report your answer to the nearest whole number.

Let \vec{h}_O be the angular momentum of A w.r.t to O. Therefore apply the definition

$$\begin{aligned}\vec{h}_O &= \vec{r}_{A/O} \times m\vec{v}_A \\ &= 3 \begin{vmatrix} \hat{i} & \hat{j} & \hat{k} \\ 1.5 & 5.8 & -1.2 \\ 4.1 & 4.4 & 5.3 \end{vmatrix} \\ &= 3(36.02\hat{i} - 12.87\hat{j} - 17.18\hat{k}) \\ &= 108.06\hat{i} - 38.61\hat{j} - 51.54\hat{k}\end{aligned}$$

Hence

$$\begin{aligned}|\vec{h}_O| &= \sqrt{108^2 + 38.61^2 + 51.54^2} \\ &= 125.794 \text{ kg}\cdot\text{m}^2/\text{sec}\end{aligned}$$

7.8.2 Problem 2

Question 2 2 pts

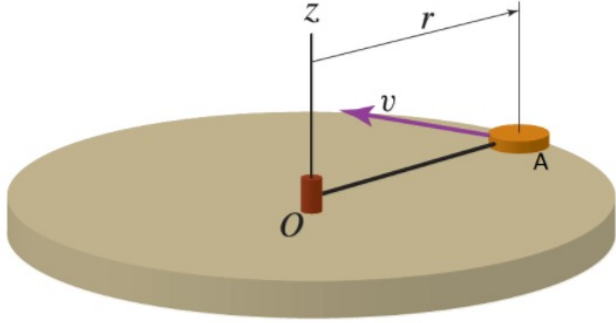

Particle A with mass 3.6 kg is attached to the origin O by a string of viscoelastic putty (silly putty) that slowly stretches. Initially A travels at speed $V=9.87$ m/s and at radius $r = r_0$ m.

What is the speed of A (m/s) when the radius is $r = 2.29r_0$

Report your answer to two decimal places.

By conservation of angular momentum

$$r_0 m v_A = 2.29 r_0 m v_2$$

$$\begin{aligned} v_2 &= \frac{v_A}{2.29} \\ &= \frac{9.87}{2.29} \\ &= 4.31 \text{ m/s} \end{aligned}$$

7.8.3 Problem 3



Particles A (mass 9.8 kg) and B (mass 8.3 kg) are on a massless rod with length $L=5.0$ meters which spins about the origin O. There is a linear motor at the origin that can move the bar back and forth relative to the origin, without applying a moment to the system. Initially particle B is at the origin O and particle A is traveling with a speed of $V_A=3.70$ m/s (shown above).

The linear motor at O slowly moves the rod, so that A moves toward O and B moves away from O. There are no other forces or moments.

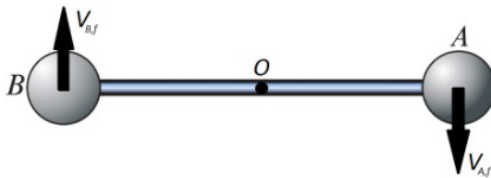

When the rod is centered at O (as seen above), what is the velocity of B (m/s)?

Report your answer to two decimal places.

Angular momentum initially

$$\begin{aligned}\bar{h}_1 &= \bar{r}_{A/O} \times m_A \bar{v}_A \\ &= 9.8 \begin{vmatrix} \hat{i} & \hat{j} & \hat{k} \\ 5 & 0 & 0 \\ 0 & -3.7 & 0 \end{vmatrix} \\ &= -181.3 \hat{k} \end{aligned} \quad (1)$$

In new state, we first note that $|\bar{v}_{A_2}| = |\bar{v}_B|$ since both are the same radius from origin. This means $|v_{A_y}| = |v_{B_y}|$ since they move only in y direction. Then

$$\begin{aligned}\bar{h}_2 &= \bar{r}_{A/O} \times m_A \bar{v}_{A_2} + \bar{r}_{B/O} \times m_B \bar{v}_B \\ &= 9.8 \begin{vmatrix} \hat{i} & \hat{j} & \hat{k} \\ 2.5 & 0 & 0 \\ 0 & -v_{A_y} & 0 \end{vmatrix} + 8.3 \begin{vmatrix} \hat{i} & \hat{j} & \hat{k} \\ -2.5 & 0 & 0 \\ 0 & v_{B_y} & 0 \end{vmatrix} \\ &= 9.8 \begin{vmatrix} \hat{i} & \hat{j} & \hat{k} \\ 2.5 & 0 & 0 \\ 0 & -v_{B_y} & 0 \end{vmatrix} + 8.3 \begin{vmatrix} \hat{i} & \hat{j} & \hat{k} \\ -2.5 & 0 & 0 \\ 0 & v_{B_y} & 0 \end{vmatrix} \\ &= -46.5 v_{B_y} \hat{k} \end{aligned} \quad (2)$$

Since (1) and (2) are equal (conservation of angular momentum) then

$$v_{B_y} = \frac{-181.3}{-46.5} = 3.899 \text{ m/s}$$

7.9 Quiz 9

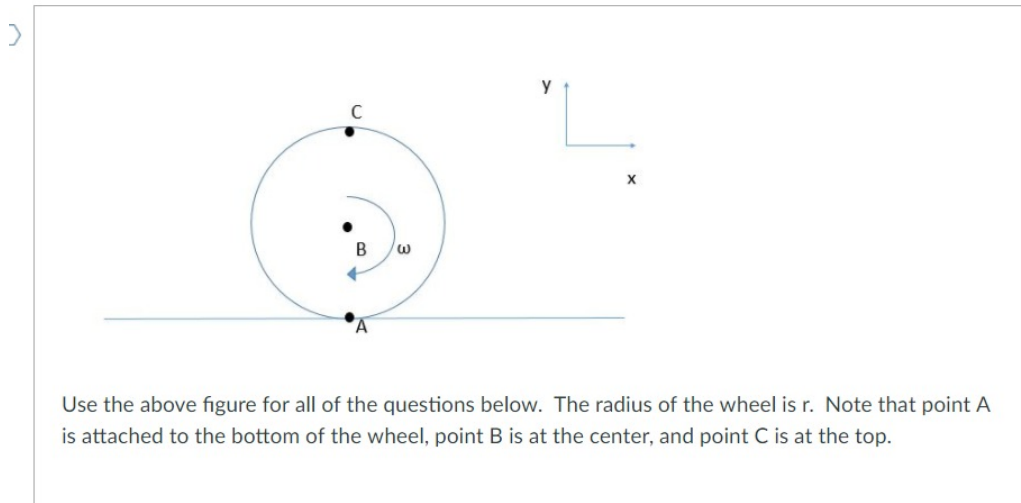

7.9.1 Problem 1

Question 1	1 pts
Assume the wheel is traveling to the right and rolling without slip. What is the velocity at point C?	
<input type="radio"/> $2r\omega$	
<input type="radio"/> $r\omega^2$	
<input type="radio"/> $r\omega$	
<input type="radio"/> not enough information	

$2r\omega$

7.9.2 Problem 2

Question 2	1 pts
Assume the wheel is slipping such that the velocity of point B is zero. Where is the instantaneous center of velocity of the wheel located?	
<input type="radio"/> point B	
<input type="radio"/> point A	
<input type="radio"/> No instantaneous center exists	
<input type="radio"/> none of the above	

Point B

7.9.3 Problem 3

Question 3	1 pts
For a wheel that is slipping such that the velocity of B is zero. How are the velocities of point A and C related?	
<input type="radio"/> Equal magnitude opposite direction	
<input type="radio"/> Equal magnitude and same direction	
<input type="radio"/> no relationship	
<input type="radio"/> none of the above	

Equal and opposit

7.9.4 Problem 4

Question 4	1 pts
Assume the wheel is traveling to the right and rolling with slip. The angular velocity of the wheel points in direction shown in the figure.	
Where is the instantaneous center of velocity for the wheel located?	
<input type="radio"/> Between points A and B	
<input type="radio"/> Point A	
<input type="radio"/> Point B	
<input type="radio"/> Point C	
<input type="radio"/> Not enough information	

Between A and B

7.10 Quiz 10

7.10.1 Problem 1

Question 1

1 / 1 pts

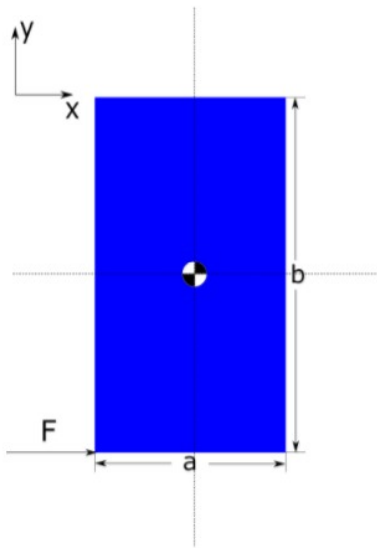

A rectangular body with mass 3 kg, width $a=0.3$ m and height $b=0.7$ m as seen above is acted upon by a force $F=30$ N in the bottom corner in the x-direction as seen above. The body lies on a horizontal plane. The center of gravity is at the geometric center of the object.

What is the acceleration of the body's center of mass in the x-direction (in m/s^2)?

Report your answer to two decimal places

7.10.2 Problem 2

Question 2

1 / 1 pts

Same situation as the previous question.

What is the angular acceleration of the object (in radians/s^2)?

Report your answer to two decimal places.

7.10.3 Problem 3

Question 3 1 / 1 pts

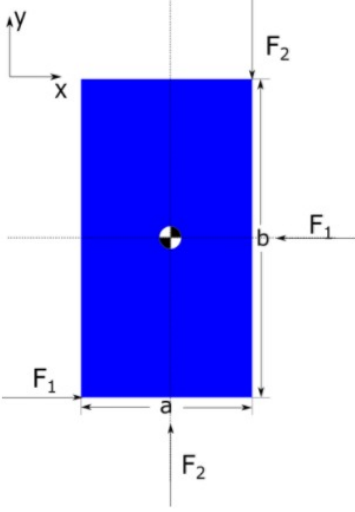

The same rectangular body now has four thrusters attached to it. These thrusters will exert the forces shown above, and will move and rotate with the body if it begins to move or rotate. The forces are $F_1=6$ N, and $F_2=4$ N.

If the thrusters are turned on when the object is at rest, what is the displacement in the x-direction (in m) in 2 seconds?

Report your answer to two decimal place.

7.10.4 Problem 4

Question 4 1 pts

Same situation as the previous question.

How many radians does the object rotate 2 seconds after the thrusters are turned on from rest?

Report your answer to one decimal place.

20.69 rad/sec

7.10.5 Problem 5

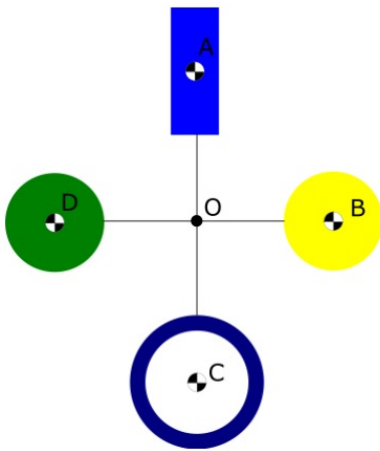

An windmill art project consists of four objects welded together. The art project will be mounted such that it spins about point O. Object A is a thin rectangular plate with mass 2.3 kg, width 0.02 m and height 0.08 m whose center of mass is 0.30 m from O. Object B is a thin disk with mass 2.6 kg, radius 0.06 m, and whose center of mass is 0.22 m from O. Object C is a thin ring with mass 2.9 kg, radius 0.05 m, and whose center of mass is 0.49 m from O. Object D is a sphere with mass 2.7 kg, radius 0.09 m whose center of mass is 0.26 m from O. Objects A-D are connected by mass-less thin rods.

What is the moment of inertia about point O (in $\text{kg}\cdot\text{m}^2$)?

Report your answer to three decimal places.

1.24

Calculation is below

```

ma=2.3;
b=0.02;
h=0.08;
oA=0.3;
IAo=1/12 ma (b^2+h^2) + ma * oA^2
Out [140]= 0.20830333333333333
mb=2.6;
rb=0.06;
oB=0.22;
IBo=mb * rb^2/2 + mb * oB^2
Out [144]= 0.13052
mc=2.9
rc=0.05
oC=0.49;
ICo=mc *rc^2 + mc * oC^2
Out [148]= 0.70353999999999999
md=2.7;
rd=0.09;
oD=0.26;
IDo=2/5 md rd^2 + md * oD^2
Out [152]= 0.19126800000000001
total=IAo+IBo+ICo+IDo
Out [153]= 1.2336313333333333

```

7.11 Quiz 11

7.11.1 Problem 1

Question 1	2.5 pts
<p>A bicycle wheel is spun up to an angular velocity of 13.3 rad/s, then the tire is pressed against the ground until the wheel stops rotating. Assume that the bicycle's horizontal and vertical positions remain fixed.</p> <p>Knowing that the kinetic friction coefficient is 0.3 and the wheel rotated 3 complete revolutions before stopping, determine the average vertical force in (N) used to press the tire onto the ground. (assume the vertical force is a combination of the wheel's weight and the person's holding force)</p> <p>The wheel can be modeled as a 1.1 kg ring with radius 0.3 m.</p> <div style="border: 1px solid #ccc; height: 20px; width: 150px; margin-top: 10px;"></div>	

Applying work energy for rigid bodies

$$T_1 + V_1 + \int_0^{\theta_2} M d\theta = T_2 + V_2$$

But $V_1 = V_2$, and let $F = \mu_k P$, where P is the force pushing down and F is the friction force, then

$$\begin{aligned} \frac{1}{2} I_{cg} \omega_1^2 + \int_0^{\theta_2} M d\theta &= 0 \\ \frac{1}{2} (mr^2) \omega_1^2 + \int_0^{\theta_2} -F r d\theta &= 0 \\ \frac{1}{2} (mr^2) \omega_1^2 + P \mu_k r \theta_2 &= 0 \end{aligned}$$

But $\theta_2 = 6\pi$ since 3 revolutions, then

$$\frac{1}{2} (mr^2) \omega_1^2 - P \mu_k r (6\pi) = 0$$

Solving for P

$$\begin{aligned} P &= \frac{\frac{1}{2} (mr^2) \omega_1^2}{\mu_k r (6\pi)} \\ &= \frac{\frac{1}{2} (1.1) (0.3)^2 (13.3)^2}{(0.3) (0.3) (6\pi)} \\ &= 5.161 \text{ N} \end{aligned}$$

7.11.2 Problem 2

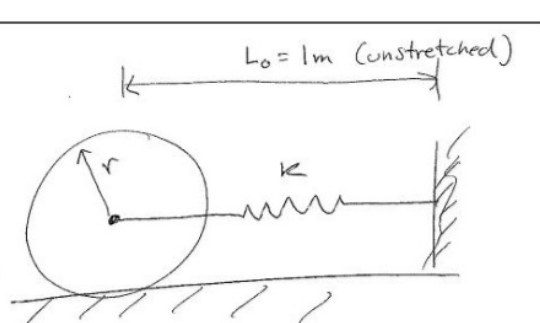
Question 2	2.5 pts
	
<p>A 14.0 kg thin disc of radius 0.5 m is attached to a spring with initial length 1m. The spring constant $k = 20 \text{ N/m}$</p> <p>The disc is rolled backwards until the spring is stretched to 2.7 m, then the disc is released from rest. Assuming roll without slip, determine the velocity in (m/s) at the center of the disc when the spring length reaches 1m.</p>	
<input style="width: 150px; height: 20px; border: 1px solid black;" type="text"/>	

When the disk is pulled, it gains potential energy $V_1 = \frac{1}{2}kx^2$ where x is amount of spring extension from equilibrium, which is 1.7 meter in this example. When released, all this energy will be converted to kinetic energy when the disk reaches its original equilibrium position. The final kinetic energy is $T_2 = \frac{1}{2}mv_g^2 + \frac{1}{2}I_{cg}\omega^2$. But since the disk rolls without slip, then $v_{cg} = r\omega$ and

$$T_2 = \frac{1}{2}mv_g^2 + \frac{1}{2}I_{cg}\frac{v_{cg}^2}{r^2}$$

But $I_{cg} = \frac{1}{2}mr^2$ and the above becomes

$$\begin{aligned} T_2 &= \frac{1}{2}mv_g^2 + \frac{1}{4}mr^2\frac{v_{cg}^2}{r^2} \\ &= \frac{1}{2}mv_g^2 + \frac{1}{4}mv_{cg}^2 \\ &= \frac{3}{4}mv_{cg}^2 \end{aligned}$$

Hence equating the initial potential energy to the final kinetic energy we obtain

$$\frac{1}{2}kx^2 = \frac{3}{4}mv_g^2$$

Solving for v_g gives

$$\begin{aligned} v_{cg}^2 &= \frac{\frac{1}{2}kx^2}{\frac{3}{4}m} \\ &= \frac{2}{3}\frac{kx^2}{m} \\ &= \frac{2}{3}\frac{(20)(1.7)^2}{14} \\ &= 2.7524 \end{aligned}$$

Therefore

$$\begin{aligned} v_{cg} &= \sqrt{2.7524} \\ &= 1.659 \text{ m/s} \end{aligned}$$