

**University Course**

**EMA 542  
Advanced Dynamics**

**University of Wisconsin, Madison  
Fall 2013**

My Class Notes

**Nasser M. Abbasi**

Fall 2013



# Contents

<b>1</b>	<b>Introduction</b>	<b>1</b>
1.1	Class grading . . . . .	3
1.2	Homework solution method . . . . .	4
1.3	Team evaluation form . . . . .	8
<b>2</b>	<b>Project</b>	<b>9</b>
2.1	Initial proposal . . . . .	11
2.2	Report . . . . .	23
<b>3</b>	<b>cheat sheets</b>	<b>53</b>
3.1	First exam . . . . .	54
3.2	Second exam . . . . .	55
3.3	Final exam . . . . .	56
<b>4</b>	<b>Hws</b>	<b>57</b>
4.1	HW 1 . . . . .	58
4.2	HW 2 . . . . .	87
4.3	HW 3 . . . . .	103
4.4	HW 3 different solution . . . . .	116
4.5	HW 4 . . . . .	126
4.6	HW 5 . . . . .	140
4.7	HW 6 . . . . .	160
4.8	HW 7 . . . . .	173
4.9	HW 8 . . . . .	192
4.10	HW 9 . . . . .	209
4.11	HW 10 . . . . .	231
4.12	HW 11 . . . . .	244



# Chapter 1

## Introduction

### Local contents

1.1	Class grading . . . . .	3
1.2	Homework solution method . . . . .	4
1.3	Team evaluation form . . . . .	8

Fall 2013. Part of MSc. in Engineering Mechanics.

Instructor: professor Daniel Kammer

school course description

Textbook: Instructor own book.

## 1.1 Class grading

EMA 542 - Advanced Dynamics

Semester I, 2013-2014

<b>Basis for Final Grade:</b>	<b>Percentage of Grade</b>
1) Homework -	15
2) Two In-Class Hour Exams - Exam 1 - Friday, October 11 <sup>th</sup> Exam 2 - Friday, November 22 <sup>nd</sup>	40
3) Project	20
4) Cumulative Final Exam -	25

## 1.2 Homework solution method

### Suggested Problem Solving Procedure for EMA 542

The following is a suggested format for writing up homework problems in EMA 542. While it is not required that the student follow the format completely, the following steps prove to be useful to both the grader and the student. (Some more useful than others.) These steps assist in developing an organized approach to problem solving for the student. Furthermore, the steps are intended to delineate the intentions of the student in his/her solution, preventing confusion on the part of the grader. Note that the steps 7-9 are to be performed at the same time as needed.

Each problem should (ideally) contain the following:

1. Your name
2. Problem number
3. Read problem statement
4. Write problem statement:
  - Identify the given information: dimensions, constants, forces, etc.
  - Write down the quantity that the problem is asking for.
5. Provide a general diagram:
  - Diagram should portray the physical components of the structure that is being analyzed.
  - All points, dimensions, and angles that are referred to in the solution of the problem should be included in the diagram or subsequent diagrams.





- Try not to change the notation of the problem statement, unless you really need to. (Get used to adapting to someone else's notation.)

(Note: Steps 3, 4 and 5 are intended to give the student a physical sense of the problem, as well as a sense for what is involved in the solution process.)

6. State the governing laws that define the mathematical model of the physical problem:

- Provide the equations of motion and equations that define the kinematics of the problem.
- List all the assumptions that make the equations valid for this physical problem. (ex. Assume that all members are rigid bodies, point P is the mass center of bar C-D, bar A-C will be idealized as a thin rod, etc.)

(Note: Assumptions that need to be made as the problem progresses can be stated as they are used. One large section of assumptions is not needed. The point here is to prove to yourself and to the grader that your methods are valid.)

7. Draw diagrams or partial diagrams of the system:

- Free body diagrams of all of the components that require force analysis should be included.
- A diagram of the coordinate system is **essential** along with a description of its placement and angular velocity components. (ex. "The rotating coordinate system with base vectors  $x'$ ,  $y'$ ,  $z'$  is fixed w.r.t. the platform. Therefore it rotates with the same angular velocity as the platform. This can be expressed in either the fixed coordinate system or the rotating coordinate system,"

$$\vec{\omega}_{cs} = \Omega \vec{e}_K = \Omega \vec{e}_{z'}$$

$$\dot{\vec{R}}_P = -\Omega b \hat{e}_{r'}$$

if (b) is the radius of the platform.

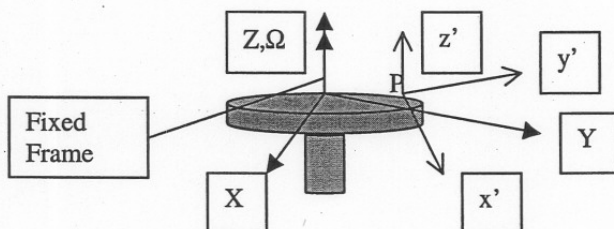

- All vectors (position, velocity, acceleration, force, moment, etc.) that are given in the problem statement should be drawn in a general configuration with respect to the coordinate system of choice. Include angles between vectors and base vectors (unit vectors in the directions of the coordinate axes). Vectors that are derived may or may not need to be shown in a diagram.
  - It is important that diagrams show a **general** configuration of the structure with all angles and position vectors labeled. (This is important because the novice analyst might forget to break up a vector into components in any general position of the coordinate system chosen to analyze the problem. Remember that a vector must be expressed in general in order to take its derivative.)
8. Clearly write out all of the vectors used in all equations. Make sure that the vector is expressed in terms of the base vectors in the coordinate system of choice. (ex.

“expressing the angular velocity of the rotating coordinate system  $x', y', z'$  in terms of the base vectors in the rotating coordinate system  $e_i, e_j, e_k$ :

$$\vec{\omega}_{cs} = 0\hat{e}_i + 0\hat{e}_j + \Omega\hat{e}_k.”$$

9. Derive the quantity (velocity, acceleration, equation of motion, etc.) that was asked for in the problem statement:
- Do this for any general configuration (symbolically) if possible. This technique becomes cumbersome with complicated problems though.
  - Tell a story as you proceed with the calculations. Use diagrams with labels every time that a new symbol is used in the calculations. Use phrases like: “From FBD”, “Taking moments about A”, “Substituting from equation 1.”, “noting that pt. B is a fixed point”, “the coordinate system translates with velocity  $\Omega r$  and rotates...” etc.
  - Break up a large expression (such as that for acceleration) into logical components. Calculate the components and then substitute into the large expression. (ex.  $\vec{a} = \ddot{R}_o + \vec{\omega}_{cs} \times (\vec{\omega}_{cs} \times \vec{\rho}) + \dot{\vec{\omega}}_{cs} \times \vec{\rho} + \ddot{\rho}_r + 2\omega_{cs} \times \dot{\rho}_r$  can be broken up into the following components:  
 $\ddot{R}_o, \vec{\omega}_{cs} \times (\vec{\omega}_{cs} \times \vec{\rho}), \dot{\vec{\omega}}_{cs} \times \vec{\rho}, \ddot{\rho}_r, 2\omega_{cs} \times \dot{\rho}_r.$
  - Carrying over units is always a good practice. Having units that work out to the expected unit of the answer is a necessary condition for having your answer correct.
10. Check to see if the answer makes sense physically:
- Are the components in the direction that was anticipated?
  - Do the signs of vector components make sense?
  - Does the relationship between coordinates (degrees of freedom) and other quantities make sense?
  - If not, try to point out where the mistake is.

**It is not intended that the steps should be rigorously followed for each problem. The point is that the student should have an organized plan of attack for each problem that he/she is able to justify and clearly relate to a colleague. Missing steps will certainly not result in a deduction of points. But if the student’s work is not understandable by the grader, points will be taken off and it will be up to the student to see the grader and reconcile their differences.**

### Advice and Things to Remember

1. Read the section in the notes **before** lecture.
2. Understand the derivations of the fundamental equations.  
 These suggestions will allow the student to get the most out of lectures. Instead of trying to keep up with the deluge of new information presented in lectures, the student will learn about the mathematical representations of physical quantities at his/her own pace. Derivations will be studied in order to see how the final equation has evolved from basic physical principles, and gain insight into the limitations of the equations. Lecture is then an opportunity for reinforcement of

- ideas and clarification of misunderstandings. The student will be able to ask the right questions in lecture.
3. Understand derivations and equations on a mathematical and physical level. This skill will enable the student to use equations as a powerful tool, instead of just attempting to repeat a procedure learned in class.
4. Derivatives of vectors can only be taken when the vectors are expressed in the most general form.
5. Vectors such as acceleration and velocity represent physical quantities that are independent of the coordinate system that they are expressed in. Thus the velocity of a particle expressed in one frame is the same as the velocity of a particle expressed in any other frame. The vector is just written in terms of components along different base vectors. Thus the components will be different.
6. Because of 5, it may be useful to calculate the acceleration of, say, the center of a rotating frame using a fixed coordinate system. Then the acceleration vector (which is originally expressed in terms of fixed base vectors) can be written in terms of the base vectors of the rotating coordinate system by using a coordinate transformation.
7. Remember the conditions under which equations are valid. This goes hand in hand with understanding derivations.
8. Take the work you do in this class personally. As an engineer, it is up to you to be able to analyze a system correctly with the proper assumptions. Every mistake can cost lives. Take pride in the power of the material you are learning and know that some day the knowledge gained in this course will elevate the human existence.

## 1.3 Team evaluation form

**EMA 542**  
**Confidential Team Evaluation**  
**Due: end of semester.**

Please carefully consider the amount of effort and the performance that you and your teammates put into the design project. Divide up the effort and performance according to your honest evaluation by assigning “points” to yourself and each of your teammates. If everyone contributed equally, then each person should be awarded the same number of points, totaling 100. **This evaluation will be kept confidential.**

The results from all team members will be considered when awarding grades to each person.

Your name: \_\_\_\_\_ Points: \_\_\_\_\_

Your teammates' names:

1. \_\_\_\_\_ Points: \_\_\_\_\_

2. \_\_\_\_\_ Points: \_\_\_\_\_

3. \_\_\_\_\_ Points: \_\_\_\_\_

4. \_\_\_\_\_ Points: \_\_\_\_\_

Total: \_\_\_\_\_ Total: 100 points.

**Comments. If points are divided up unequally, please provide an explanation.**

Signature: \_\_\_\_\_ Date: \_\_\_\_\_

I hereby attest that this evaluation represents a fair and honest allocation of points based on my own and my teammates true efforts.

# Chapter 2

## Project

### Local contents

2.1	Initial proposal . . . . .	11
2.2	Report . . . . .	23

Project simulation moved to my Mathematica demo web page here

## 2.1 Initial proposal

### Structural Dynamics Research Corporation (SDRC) Disneyland project proposal

Daniel Belongia    Adam Mayer    Donny Kuettel    Nasser M. Abbasi

December 25, 2015

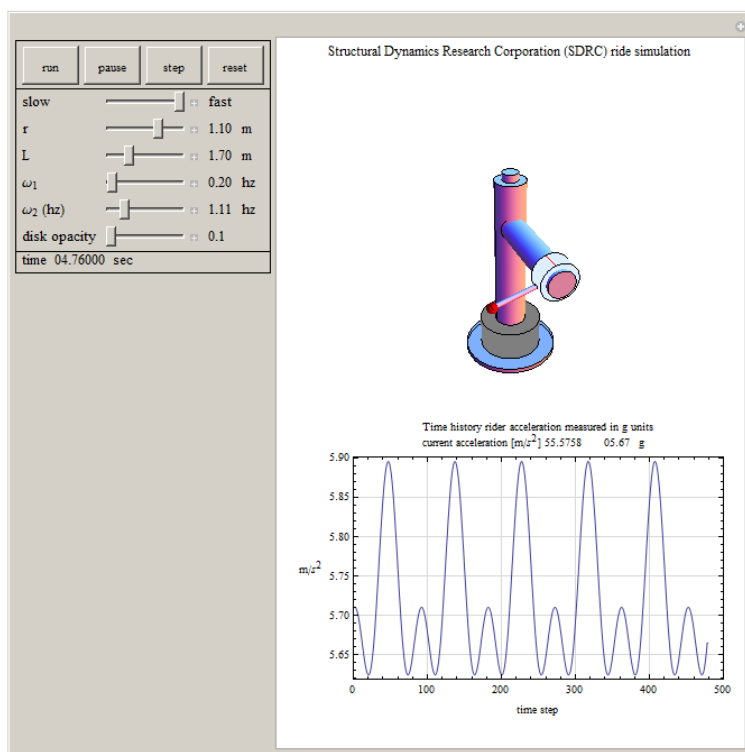

## Contents

<b>1</b>	<b>Introduction</b>	<b>3</b>
<b>2</b>	<b>Safety considerations</b>	<b>3</b>
<b>3</b>	<b>Mathematical model of system dynamics</b>	<b>5</b>
<b>4</b>	<b>Conclusion</b>	<b>7</b>
<b>5</b>	<b>Appendix</b>	<b>8</b>
5.1	Ride velocity and acceleration derivation . . . . .	8
5.2	Design renderings of final ride construction . . . . .	9
5.3	Parameters used in design . . . . .	10
5.4	Customer feedback . . . . .	10
<b>6</b>	<b>References</b>	<b>11</b>



## List of Figures

1	Gantt Chart showing project progress timeline . . . . .	4
2	Showing main dimensions of ride design . . . . .	5
3	Time history plot for absolute acceleration of ride object for first 5 seconds . . . . .	6
4	Ride description showing rotating coordinate system . . . . .	8
5	View of ride object in rotating coordinates system . . . . .	8
6	Showing ride seating mechanism . . . . .	10
7	Customer feedback from the project proposal . . . . .	11

## List of Tables

1	Gantt chart explanation . . . . .	4
2	ride configuration used in design . . . . .	6
3	Material parameters . . . . .	10

## 1 Introduction

A four-member team at Structural Dynamics Research Corporation (SDRC) has completed the preliminary design for a new spinning ride for Disneyland.

The team includes one graduate student and three undergraduate students in Engineering Mechanics and Astronautics, whose experience in advanced and structural dynamics will contribute to the creation of a world-class ride. Additional skills that the team will bring to the table include extensive programming experience in Matlab and Mathematica, as well as finite element modeling in Ansys.

The ride features two non-collinear components of angular velocity, and the head of each of the two passengers will experience a maximum of  $6g$  of acceleration. The ride is specifically designed to be light, safe, affordable, and fun.

The team at SDRC would like to perform a more detailed design and analysis of the ride, so the following pages provide contractors at Disneyland with an overview of what they can expect from the ride. Safety considerations and acceleration calculations are highlighted, and some information on team members and a project management plan are also included.

The next step after this initial proposal will be a detailed structural and failure analysis on the system, which Disneyland can expect in December.

## 2 Safety considerations

The Flight Simulator will be equipped with multiple safety measures to ensure that the pilots have a fun and exciting ride. In order to ride the Flight Simulator, each passenger must be at least 5 feet tall. This insures that the riders can be securely fastened into the seat. Assuming an average rider weight of 175 pounds, one single rider cannot weigh more than 350 pounds.

Any more weight will induce a moment on the main arm that might be considered unsafe. A factor of safety will be factored into the building of the arm in case two riders combined weight to be more than 350 pounds.

This is because with the extended arm and accelerations the main arm will be subject to, it is believed to be the first membrane to fail. In order to start the ride, it must be certain that the arm will not break during the ride. While riding, each rider will be harnessed into his or her seat via a 3-point harness.

The harness will let the passengers fly upside-down while still secured in the cockpit. Since the Flight Simulator will be subject to  $6g$  acceleration, complementary sick bags will be provided upon starting.

In case of a medical emergency of a passenger or if it has been determined that it is unsafe to ride mid-flight, an emergency stop will be activated which will bring the ride to an end. When activated, the ride will right itself upwards while bringing itself to a stop about the center of the ride. This is so when the ride stops, the passengers are not hanging upside down which would be unsafe.

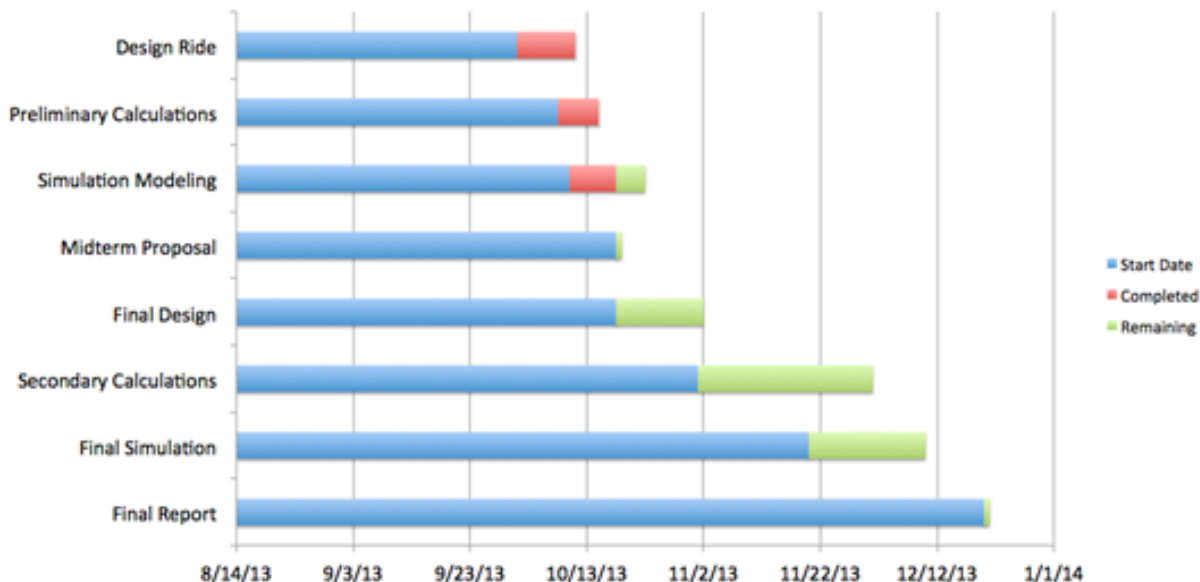

Figure 1: Gantt Chart showing project progress timeline

The following table describes the activities shown on the Gantt chart above.

Activity	Description
Design ride	Coming up with a ride that would be functional and meets all expectations.
Preliminary calculations	With ride chosen, calculations showing the velocity and acceleration of the rider’s head symbolically.
Simulation modeling	Modeling the ride with a simulator with sliders to estimate the angular velocities.
Midterm proposal	When the midterm proposal of the ride is requested by the company.
Final design	Finalizing how the ride will work.
Secondary calculations	After finalizing how ride will work, will compute secondary calculations to know which velocities will work to add up to give the desired acceleration for each passenger.
Final modeling	Once the angular velocities are known, make a model to show how the ride will work when everything comes together.
Final report	When the customer wants the final report to know if they would like to purchase the ride that we have created.

Table 1: Gantt chart explanation

### 3 Mathematical model of system dynamics

The velocity and acceleration of the ride object was derived such that it is valid for all time. The derived equations are used in a simulation program written for this proposal in order to generate the acceleration time history and be able to modify the ride parameters more easily to find the optimal combination to meet the given specifications of maximum  $6g$  customer requirements.

The simulation was done assuming the ride is at steady state, hence angular accelerations are set to zero. The following diagram illustrates the four design parameters used in the simulation and the expressions found for the velocity and acceleration. The appendix contains the detailed derivation.

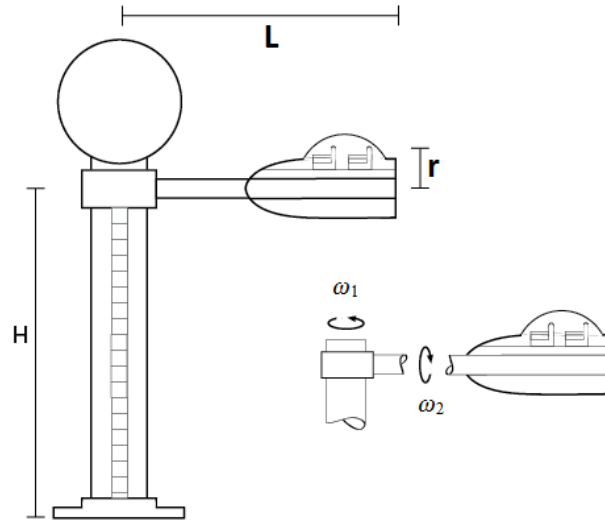

**Figure 2:** Showing main dimensions of ride design

The absolute velocity of the ride was found to be

$$\vec{V} (r\omega_2 \cos \omega_2 t - \omega_1 L) \vec{i} + \omega_1 r \sin \omega_2 t \vec{j} - r\omega_2 \sin \omega_2 t \vec{k}$$

And the absolute acceleration is

$$\begin{aligned} \vec{a} = & \vec{i} \left( r\dot{\omega}_2 \cos \omega_2 t - r\omega_2^2 \sin \omega_2 t + \dot{\omega}_1 L - \omega_1^2 r \sin \omega_2 t \right) \\ & + \vec{j} \left( 2r\omega_1 \omega_2 \cos \omega_2 t + \dot{\omega}_1 r \sin \omega_2 t - \omega_1^2 L \right) \\ & + \vec{k} \left( -r\dot{\omega}_2 \sin \omega_2 t - r\omega_2^2 \cos \omega_2 t \right) \end{aligned}$$

The following diagram gives the acceleration time history for the ride. This plot was generated for the first 5 seconds of the ride in steady state. It shows that the maximum acceleration did not exceed  $6g$  during the simulation which included more than 5 complete cycles. The following table shows the ride configuration used to achieve the above time history. These values are the anticipated design parameters to use to complete the structural analysis, but these could change based on results of the structural design.

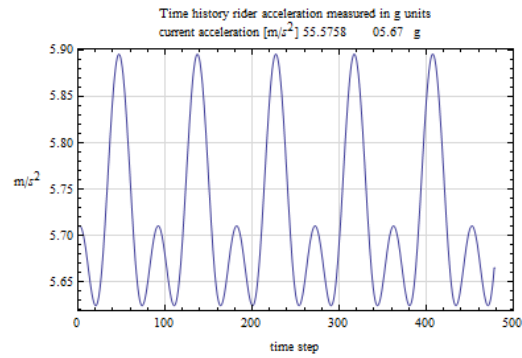

**Figure 3:** Time history plot for absolute acceleration of ride object for first 5 seconds

**Table 2:** ride configuration used in design

Length of beam ( $L$ )	1.7 meter
Height of person head above beam ( $r$ )	1.1 meter
Angular velocity of ride cabinet ( $\omega_2$ )	0.2 Hz
Angular velocity of main vertical support column ( $\omega_1$ )	1.11 Hz

## 4 Conclusion

The preliminary design for this two-passenger ride features two components of non-collinear angular velocity, and the head of each passenger experiences a maximum of  $6g$  of acceleration.

The design and calculations indicate that this will be a fun and light ride. Safety considerations were highlighted, and a management plan and team qualifications underscore the team's commitment to excellence and sound engineering. A more detailed stress analysis of the system will be delivered in December.

## 5 Appendix

### 5.1 Ride velocity and acceleration derivation

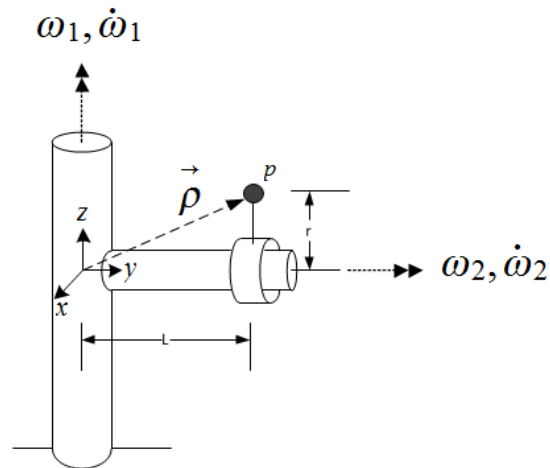

**Figure 4:** Ride description showing rotating coordinate system

The rotating coordinates system has its origin as shown in the above diagram. The coordinates system is attached to the column and therefore rotates with the column. The following calculation determines the absolute velocity of the ride object head, shown above as the circle  $p$  at distance  $r$  from the center of beam. All calculations are expressed using unit vectors of the rotating coordinates system and will be valid for all time. In the rotating coordinates system, the ride object appears as shown in the following diagram Using the above diagrams, the absolute velocity vector is found as follows

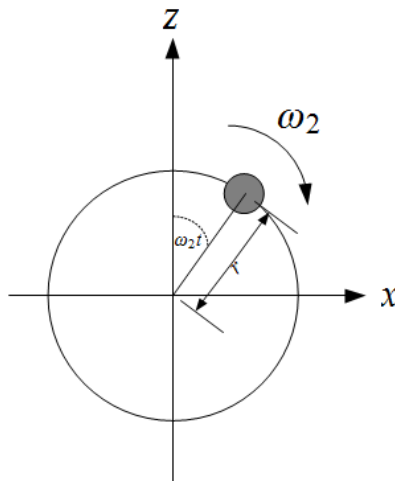

**Figure 5:** View of ride object in rotating coordinates system

$$\begin{aligned}
\vec{\rho} &= L\vec{j} + r \sin \omega_2 t \vec{i} + r \cos \omega_2 t \vec{k} \\
\dot{\vec{\rho}}_r &= r\omega_2 \cos \omega_2 t \vec{i} - r\omega_2 \sin \omega_2 t \vec{k} \\
\dot{\vec{R}} &= 0 \\
\vec{\omega} &= \omega_1 \vec{k} \\
\vec{\omega} \times \vec{\rho} &= -\omega_1 L \vec{i} + \omega_1 r \sin \omega_2 t \vec{j}
\end{aligned}$$

Hence

$$\begin{aligned}
\vec{V} &= \dot{\vec{R}} + \dot{\vec{\rho}}_r + \vec{\omega} \times \vec{\rho} \\
&= r\omega_2 \cos \omega_2 t \vec{i} - r\omega_2 \sin \omega_2 t \vec{k} - \omega_1 L \vec{i} + \omega_1 r \sin \omega_2 t \vec{j} \\
&= (r\omega_2 \cos \omega_2 t - \omega_1 L) \vec{i} + \omega_1 r \sin \omega_2 t \vec{j} - r\omega_2 \sin \omega_2 t \vec{k}
\end{aligned} \tag{1}$$

Now the absolute acceleration of the passengers is found

$$\begin{aligned}
\ddot{\vec{\rho}}_r &= \left( r\dot{\omega}_2 \cos \omega_2 t - r\omega_2^2 \sin \omega_2 t \right) \vec{i} + \left( -r\dot{\omega}_2 \sin \omega_2 t - r\omega_2^2 \cos \omega_2 t \right) \vec{k} \\
\ddot{\vec{R}} &= 0 \\
\dot{\vec{\omega}} &= \dot{\omega}_1 \vec{k} \\
\vec{\omega} \times \left( \vec{\omega} \times \vec{\rho} \right) &= \omega_1 \vec{k} \times \left( -\omega_1 L \vec{i} + \omega_1 r \sin \omega_2 t \vec{j} \right) = -\omega_1^2 L \vec{j} - \omega_1^2 r \sin \omega_2 t \vec{i} \\
\vec{\omega} \times \dot{\vec{\rho}}_r &= \omega_1 \vec{k} \times \left( r\omega_2 \cos \omega_2 t \vec{i} - r\omega_2 \sin \omega_2 t \vec{k} \right) = r\omega_1 \omega_2 \cos \omega_2 t \vec{j} \\
\dot{\vec{\omega}} \times \vec{\rho} &= \dot{\omega}_1 \vec{k} \times \left( L\vec{j} + r \sin \omega_2 t \vec{i} + r \cos \omega_2 t \vec{k} \right) = \dot{\omega}_1 L \vec{i} + \dot{\omega}_1 r \sin \omega_2 t \vec{j}
\end{aligned}$$

Hence, the absolute acceleration of the ride object head is

$$\begin{aligned}
\vec{a} &= \ddot{\vec{R}} + \ddot{\vec{\rho}}_r + 2 \left( \vec{\omega} \times \dot{\vec{\rho}}_r \right) + \left( \dot{\vec{\omega}} \times \vec{\rho} \right) + \vec{\omega} \times \left( \vec{\omega} \times \vec{\rho} \right) \\
&= \left( r\dot{\omega}_2 \cos \omega_2 t - r\omega_2^2 \sin \omega_2 t \right) \vec{i} + \left( -r\dot{\omega}_2 \sin \omega_2 t - r\omega_2^2 \cos \omega_2 t \right) \vec{k} \\
&\quad + 2r\omega_1 \omega_2 \cos \omega_2 t \vec{j} + \dot{\omega}_1 L \vec{i} + \dot{\omega}_1 r \sin \omega_2 t \vec{j} - \omega_1^2 L \vec{j} - \omega_1^2 r \sin \omega_2 t \vec{i}
\end{aligned}$$

Simplifying gives

$$\begin{aligned}
\vec{a} &= \vec{i} \left( r\dot{\omega}_2 \cos \omega_2 t - r\omega_2^2 \sin \omega_2 t + \dot{\omega}_1 L - \omega_1^2 r \sin \omega_2 t \right) \\
&\quad + \vec{j} \left( 2r\omega_1 \omega_2 \cos \omega_2 t + \dot{\omega}_1 r \sin \omega_2 t - \omega_1^2 L \right) \\
&\quad + \vec{k} \left( -r\dot{\omega}_2 \sin \omega_2 t - r\omega_2^2 \cos \omega_2 t \right)
\end{aligned} \tag{2}$$

## 5.2 Design renderings of final ride construction

The following two diagrams illustrate the completed ride construction in place, showing the main dimensions and major components



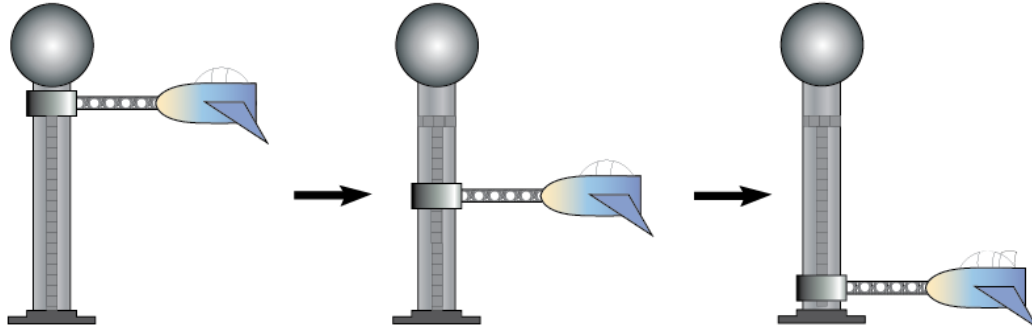

**Figure 6:** Showing ride seating mechanism

### 5.3 Parameters used in design

Material parameters used are given in the following table

**Table 3:** Material parameters

Material used for beam	Aluminium
$E$ (Young's modulus)	70 GPa
Shear modulus	26 GPa
Bulk modulus	76 GPa
Poisson ratio	0.35
Density	$2700 \text{ kg/m}^3$

### 5.4 Customer feedback

### Project Team 3 Proposal Comments

1. Next time, please use only one side of the page.
2. The Introduction is good, but you don't make any reference to the name of the ride or a figure of it. You have a figure on the cover page, but never say that it shows your ride. You need lots of figures within the text of the proposal to show the ride, and how it works to the customer.
3. You have a nice Gantt chart, but you never reference or discuss it within the proposal. You need a section that contains the discussion of your project timeline.
4. You should add a bit more detail to your analysis procedure within the text of the report, and not leave all of it for the appendix. Equations should be numbered in the right hand margin.
5. What about startup and shutdown? Are loads during these events important?
6. Figures in Section 5.2 would be good to include in the text of the report to illustrate how the ride works to the customer.
5. The Conclusion is very weak. You should summarize everything you just told the customer. This is your last chance to sell the customer on your ride. Give more details on just what you are going to deliver to the customer if the select your ride for funding.

Otherwise, pretty good!

**Figure 7:** Customer feedback from the project proposal

## 6 References

1. Aluminium page at Wikipedia <http://en.wikipedia.org/wiki/Aluminium>
2. Moments of inertia page at Wikipedia [http://en.wikipedia.org/wiki/List\\_of\\_moments\\_of\\_inertia](http://en.wikipedia.org/wiki/List_of_moments_of_inertia)
3. Density of materials page <http://physics.info/density/>
4. Beam design formulas with shear and moment diagrams book, AWC council, 2007, Washington, DC.

## 2.2 Report

### Disneyland ride final design report

Structural Dynamics Research Corporation (SDRC)

Daniel Belongia  
Adam Mayer  
Donny Kuettel  
Nasser M. Abbasi

EMA 542 Advanced dynamics  
University Of Wisconsin, Madison  
Fall 2013

**Abstract**

Dynamic analysis was completed for a new spinning ride as requested by Walt Disney Corporation. Detailed derivation of model was completed for the main structural elements using rigid body dynamics.

Critical section was identified and maximum stress calculated to insure that the member does not fail during operations and passengers acceleration does not exceed 6g.

Large software simulation program was completed to verify the model used and to allow selection of optimal design parameters.

Prepared by:

Dynamic design team  
Structural Dynamics Research Corporation (SDRC)

## Contents

<b>1</b>	<b>Introduction</b>	<b>5</b>
1.1	Gantt chart and history of design project . . . . .	6
<b>2</b>	<b>Safety considerations</b>	<b>6</b>
2.1	Locations of possible failure in the structure . . . . .	6
<b>3</b>	<b>Mathematical model of system dynamics</b>	<b>7</b>
3.1	Review of the model structure used in the design . . . . .	7
3.2	Setting up the mathematical model . . . . .	8
3.2.1	Summary of design input and design output . . . . .	11
3.2.2	System dynamic loads and free body diagram . . . . .	12
3.3	Beam to column analysis . . . . .	12
3.3.1	Finding $M_{beam}$ (beam dynamic moment) . . . . .	12
3.3.2	Finding $M_{col}$ (column dynamic moment) . . . . .	14
3.3.3	Finding $M_{cabinet}$ (cabinet dynamic moment) . . . . .	15
3.3.4	Finding $F_{cabinet}$ (cabinet dynamic linear force) . . . . .	16
3.3.5	Finding $F_{beam}$ (beam dynamic translational force) . . . . .	18
3.3.6	Using free body diagram and solving for constraint forces . . . . .	19
3.4	Column dynamic analysis . . . . .	21
<b>4</b>	<b>Simulation of the dynamic equations found</b>	<b>23</b>
4.1	Review of the simulation . . . . .	23
4.2	Simulation output, time histories and discussion of results . . . . .	24
4.3	Discussion and analysis of results . . . . .	27
4.4	Cost analysis . . . . .	28
<b>5</b>	<b>Conclusions of results and future work</b>	<b>29</b>
5.1	Future work and possible design improvement . . . . .	29
<b>6</b>	<b>Appendix</b>	<b>30</b>
6.1	Use of simulator to validate different design parameters . . . . .	30
6.2	References . . . . .	30

## List of Figures

1	Artist rendering of ride after construction . . . . .	5
2	Illustrating typical dynamic movement over four time instances for one revolution . . . . .	5
3	Time line used by the design team in the development of the final project report . . . . .	6
4	Identification of critical sections in the structure . . . . .	7
5	Main parts of the ride structure . . . . .	8
6	Main dimensions of ride structure . . . . .	8
7	relation between rotating coordinates system, body fixed coordinates system, and body principal axes. . . . .	10
8	Beam dynamics. Balancing dynamic forces to external forces and reactions . . . . .	12
9	Column dynamics. Balance with and external loads and beam transferred loads. . . . .	13
10	Configuration used for finding torque and force at beam/column joint . . . . .	13
11	Rotating coordinates system $xyz$ used to find passenger acceleration . . . . .	16
12	View of passenger head in the rotating coordinates system $xyz$ . . . . .	17
13	Rotating coordinates system $xyz$ used to find beam center of mass acceleration . . . . .	18
14	Finding the bending moment at different locations along the span of the beam . . . . .	20
15	Dynamic load balance between column and external loads . . . . .	21
16	overview of simulator user interface . . . . .	23
17	dynamic loads at the end of ride using optimal design values . . . . .	24
18	critical section current and maximum moments and stresses . . . . .	24
19	optimal set of parameters obtained from simulation. . . . .	24
20	simulator keeps track of maximum $g$ felt by passenger to insure it does not exceed $6g$ . . . . .	24
21	acceleration and velocity of passenger time history and angular velocity time history of beam and column . . . . .	25
22	time histories using the ramp down option used after reaching $6g$ goal . . . . .	26
23	Changing the structure dimensions to select optimal design using simulation . . . . .	30

## List of Tables

1	design input parameters . . . . .	11
2	design output . . . . .	11
3	design output for loading and forces using optimal parameters found . . . . .	27
4	cost estimate . . . . .	28
5	ride statistics based on optimal design parameters . . . . .	29

## 1 Introduction

A four-member team at Structural Dynamics Research Corporation (SDRC) has completed the final design for a new spinning ride for Disneyland.

The ride features two non-collinear components of angular velocity. The head of each passenger will experience a maximum of  $6g$  acceleration. Just before this acceleration is reached, the ride will enter steady state. During steady state, passengers will experience a small periodic fluctuation of acceleration that ranges between  $4.8g$  and  $6g$  but will not exceed  $6g$ . The ride can then enter the ramp down phase and starts to decelerate until it stops with smooth landing. All three phases of the ride have been simulated to insure the passengers will not exceed  $6g$  during any of the phases. The ride is specifically designed to be light, safe, affordable, and fun. The following is an artist rendering showing loading the passengers in the cabinet before starting the ride. Once the cabinet has reached the top of the support column, the ride will

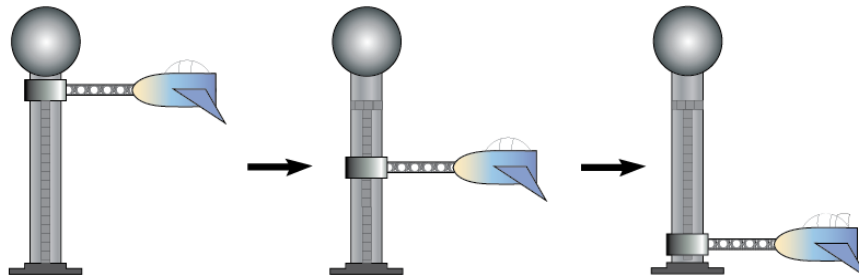

Figure 1: Artist rendering of ride after construction

start. Extensive simulation of the mathematical model of the dynamics of the model was performed to achieve an optimal set of design parameters in order to meet the design goals as specified in the customer requirements of a minimum weight and cost and at the same time insuring the structural members do not fail and that the passengers will safely achieve the  $6g$  acceleration in reasonable amount of time. The conclusion section outlines the final design parameters found. The following diagram illustrates typical one revolution ride for illustrations that was generated by the simulator developed specifically for this design contract

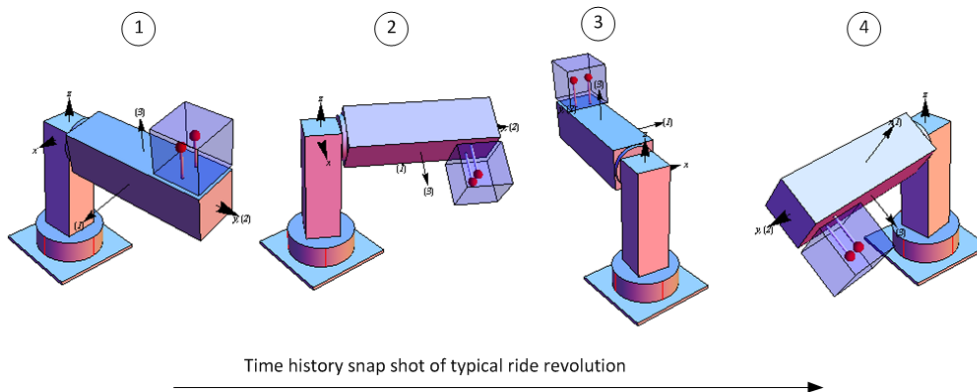

Figure 2: Illustrating typical dynamic movement over four time instances for one revolution

### 1.1 Gantt chart and history of design project

The design team followed the following timeline in the development of the report and the design. This is illustrated below using Gantt chart

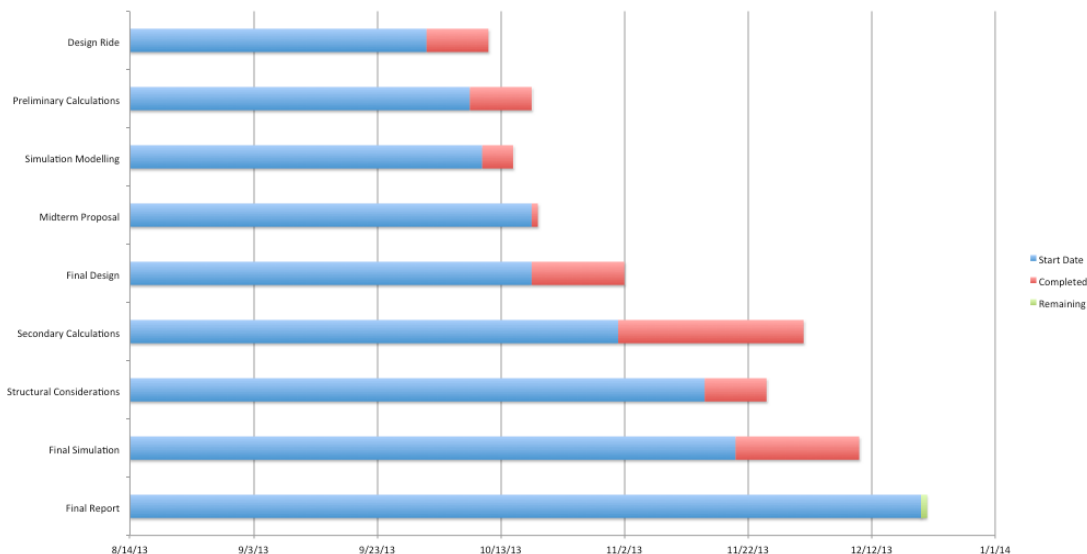

Figure 3: Time line used by the design team in the development of the final project report

## 2 Safety considerations

The flight simulator will be equipped with multiple safety measures to ensure that passengers will have a fun and exciting ride. In order to ride the flight simulator, each passenger must be at least 5 feet tall. This insures that the riders can be securely fastened into the seat. Assuming an average rider weight of 175 pounds, one single rider cannot weigh more than 350 pounds.

Any more weight will induce a moment on the main arm that might be considered unsafe. A factor of safety was factored into the building of the arm in case two riders combined weight to be more than 350 pounds. This additional weight accounts for the seating weight and the frame of the cabinet as well.

While the ride is in motion, each passenger will be harnessed into his or her seat via a 3-point harness. The harness will let the passengers fly upside-down while still secured in the cockpit. Since the flight simulator will be subject to  $6g$  acceleration, complementary sick bags will be provided upon starting.

In case of a medical emergency of a passenger or if it has been determined that it is unsafe to ride mid-flight, an emergency stop will be activated which will bring the ride to an end. When activated, the ride will right itself upwards while bringing itself to a stop about the center of the ride. This is so when the ride stops, the passengers are not hanging upside down which would be unsafe.

### 2.1 Locations of possible failure in the structure

Four critical sections in the structure were identified as possible failure sections. These are shown in the following diagram. They ranked from 1 to 4 in order of possible first to fail. Hence section 1 is the one expected to fail first.

From bending moment diagram generated during initial runs of simulation it was clear that the bending moment at section 1 was much larger than section 3. This agrees with typical cantilever beam model which the above have very close similarity when considering the cabinet as additional distributed load on the beam. However, this is a dynamic design and not static, hence time dependent bending moment and shear force diagrams are used to validate this. These diagrams were not included in the final



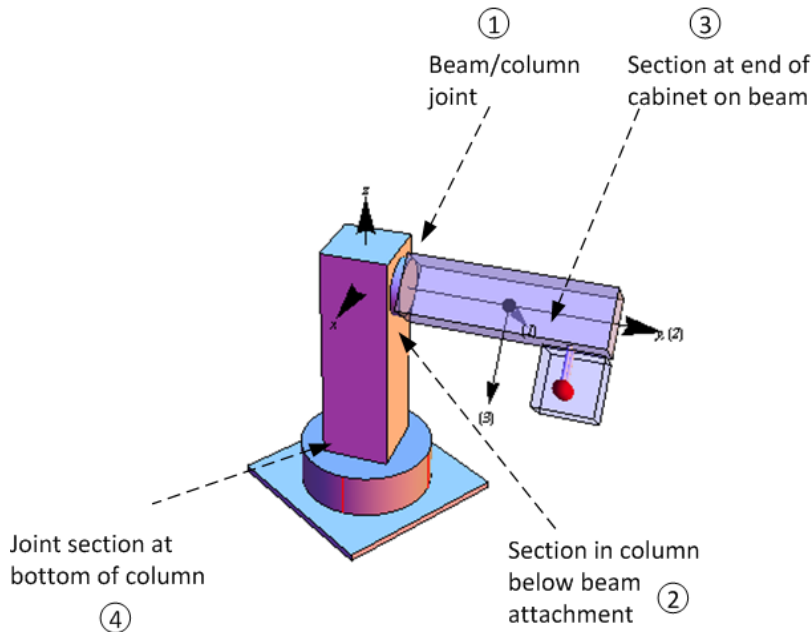

Figure 4: Identification of critical sections in the structure

simulation software due to time limitation to fully implement them in an acceptable manner. Due to also time limitations analysis for section 2 and 4 were not completed. The design team felt that protecting against failure in section 1 was the most important part at this design stage as this is the most likely failure section. If awarded the design, the team will include full analysis of all sections using finite element methods for most accurate results.

### 3 Mathematical model of system dynamics

This section explains and shows the derivation of the mathematical model and dynamic equations. These equations are used in the implementation of the software simulator in order to test and validate the design and select the final optimal design parameters.

#### 3.1 Review of the model structure used in the design

There are two rigid bodies: the beam and the supporting column. The cabinet is part of the beam but was analyzed as a rigid body on its own in order to simplify the design by avoiding the determination of moments of inertia for a composite shaped body. The following architectural drawing shows the ride structure. The ride consists of the main support vertical column attached to a spinning base. Attached to one side of the column is an aluminum beam connected to the column using a drive shaft coupling that allow the beam to spin while attached to the column. A motor supplies the power needed to spin the shaft.

The cabinet is mounted and welded on the beam. The location of the cabinet on the beam is a configurable parameter in the design, and was adjusted during simulation to find an optimal location for the seating cabinet. In final design the cabinet was located at the far end of the beam to achieve maximum passenger felt acceleration.

The passengers are modeled as one rigid body of an equal side solid cube of a mass that represents the total mass of the passengers (maximum of 2 persons) with additional mass to account for the seating weight and a factor of safety. The factor of safety was also an adjustable parameter in the simulation. The following diagram shows the main dimensions of the structure used in the design.

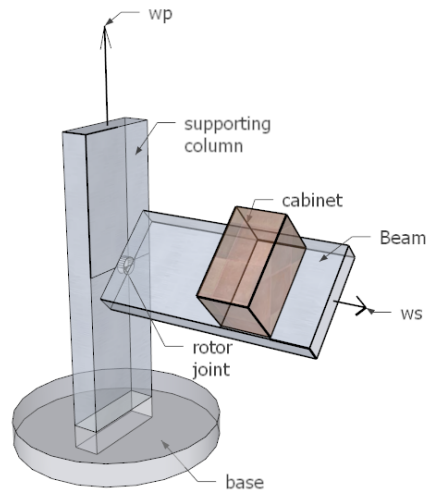

**Figure 5:** Main parts of the ride structure

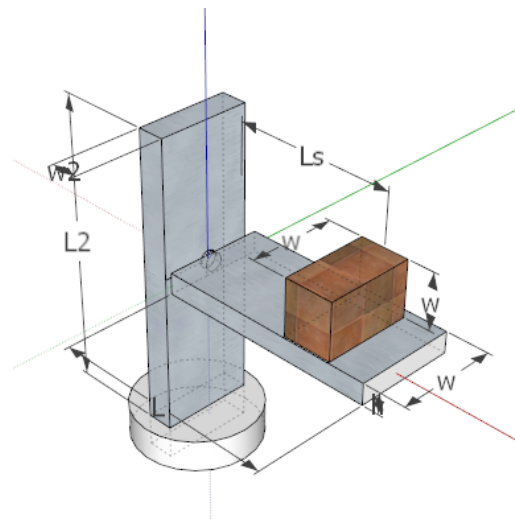

**Figure 6:** Main dimensions of ride structure

### 3.2 Setting up the mathematical model

Euler rigid body dynamic equations of motion are used to determine the dynamic moments due to the rotational motion of the rigid bodies. Principal Body axes, with its origin at the center of mass of each rigid body was used as the local body fixed coordinates system. Newton method is used to obtain the dynamics forces due to translation motion of the beam center of mass and also the center of mass of the cabinet. The column has rotational motion only and no translation motion.

After finding the dynamic forces, the unknown reaction forces at the joint between the beam and the column are solved for. Since these forces are functions of time, simulation was required to check that they remain below yield strength of Aluminium during the ride duration. Analytical solution is difficult due to the nonlinearity of the equations of motion, but a numerical solution of the equations of motion would

have been possible.

From beam bending moment diagrams generated for this design, the cross section at the beam/column joint was determined to be the critical section. This is the section which will have the maximum bending moment as well maximum shear force.

During simulation, the current values of the bending moment and shear force at the joint were tracked for each time step taken. The maximum values of these are used to determine the corresponding maximum stress concentration on the section to insure they do not reach 0.55 of yield strength of Aluminum. 0.55 was used to protect against failure in shear which can occur before failure in tension.

In order to minimize the number of parameters to vary in the design, the width of the cabinet was set to be the same as the beam width. The stresses in the beam are calculated based on simple beam theory and not plate theory. Due to time limitation, finite element analysis would not be performed. Finite element analysis would give more accurate stress calculations which would have allowed the design to be free to use less material by using thin plate for the platform and not thick beam as was used.

The following is a summary of the main steps used in the dynamic analysis process

1. Break the system into 3 separate rigid bodies
2. Use Euler and Newton methods to determine dynamic loads on each body. Principal body fixed axes are used with the reference point being the center of mass. (called case one analysis or  $\omega = \Omega$ ).
3. Draw free body diagram for each body and balance the dynamic loading found in the above step in order to solve for unknown reaction forces.
4. Apply these reaction forces to the second rigid body connected to the first body by reversing the sign on all vector. These new vectors now act as external loads on the second rigid body.
5. Perform Euler and Newton analysis on the second body to find its dynamic loads needed to cause it motion.
6. Make free body diagram for the second body to balance the external forces with the dynamic loads and remembering to use the loads found in step 3 as external loads to this second body.

This diagram below illustrates the different coordinate axes used. The rotating coordinate system that all forces are resolved for is the  $xyz$ . This has its origin at the joint between the beam and the column. This coordinate system is attached to the column and rotates with the column at an absolute angular velocity  $\omega_p$ . Each rigid body has its own local body fixed coordinate system  $x'y'z'$ . In this design,  $x'y'z'$  have the origin at the center of mass of each rigid body and are aligned with the body principal axes. Hence  $x'y'z'$  is the same as the  $e_1, e_2, e_3$  axes commonly used to mean the principal axes. Therefore  $\omega = \Omega$  in all cases. Once dynamic loads are found using  $x'y'z'$  the results are transformed back to the  $xyz$  coordinate system. This way all the results from different rigid bodies are resolved with respect to a common coordinate system  $xyz$  (which is itself a rotating coordinate system).

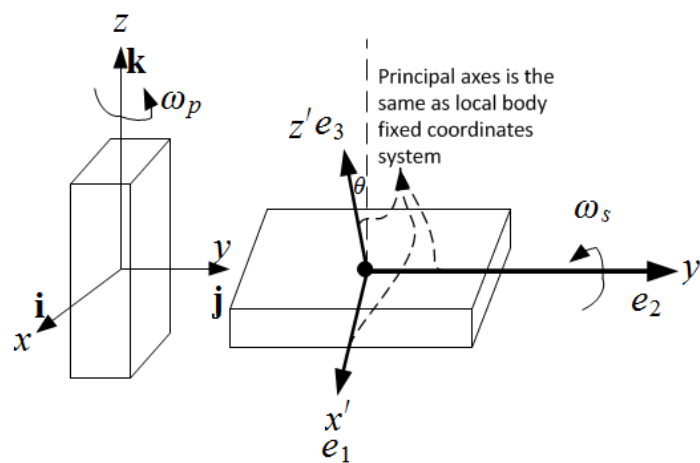

$$\Omega_{body} = \omega_p \cos \theta \mathbf{e}_3 - \omega_p \sin \theta \mathbf{e}_1 + \omega_s \mathbf{e}_2$$

The body angular velocity is the same as its coordinates system angular velocity  $x'y'z'$  and is expressed as the body absolute angular velocity but using body fixed coordinates system

**Figure 7:** relation between rotating coordinates system, body fixed coordinates system, and body principal axes.

### 3.2.1 Summary of design input and design output

The following tables summarize the input and the output of the overall design. The tables list all the design parameters and the meaning and usage of each. They show what is known at the start of the design and the output from the design and simulation

Parameter name	Meaning and usage
$\rho$	Density of Aluminum 2700 $\frac{kg}{m^3}$ , $E = 69$ GPa, Max tensile 125 MPa, Max yield strength 55 MPa
$q$	Mass per unit length of the beam
$L$	Length of the beam
$L_s$	Distance to the center of cabinet from the left edge of the beam
$h$	Thickness of the beam (rectangular cross section beam)
$b$	Width of the beam and cabinet
$\dot{\omega}_p$	Angular acceleration of vertical column (zero at steady state)
$\dot{\omega}_s$	Angular acceleration of platform and cabinet (zero at steady state)
$m$	Total mass of cabinet. 175 lbs per person, total of two persons including additional 200 lbs for seats
$M$	Mass of main support column. Fixed in design
$gLimit$	Maximum acceleration felt by rider. Must not exceed 6 g
$\sigma_{yield}$	Yield tensile stress for Aluminum. 55 MPa

**Table 1:** design input parameters

The following table shows the output of the design based on the above input. Simulation was used to find an optimal set of input parameters in order to achieve the customer specifications

Parameter name	Meaning and usage
$\mathbf{a}_m$	Acceleration time history experienced by passenger. Not to exceed 6g
$\mathbf{F}_{weld}$	Reaction forces at joint connecting the beam with the column
$\mathbf{M}_{weld}$	Reaction moment at joint connecting the beam with the column
$\omega_p$	Column angular velocity time history
$\omega_s$	Beam angular velocity time history
$\sigma$	Direct stress tensor at critical section (joint between beam and column)
$\tau$	Shear stress tensor at critical section (joint between beam and column)
$\sigma_{max}$	Maximum direct stress recorded, must remain below yield stress for Aluminium
$\tau_{max}$	Maximum shear stress recorded, must remain below 0.55 of tensile yield stress
$a_{max}$	Maximum acceleration reached by riders. Must be as close as possible to 6g
$v_{max}$	Maximum velocity reached by riders. Typical value from simulation was 180 m.p.h.

**Table 2:** design output

### 3.2.2 System dynamic loads and free body diagram

Before starting the derivation, the following two diagrams are given to show the dynamic loads to be balanced with constraint forces. Two free body diagrams used. One for the beam and one for the column.

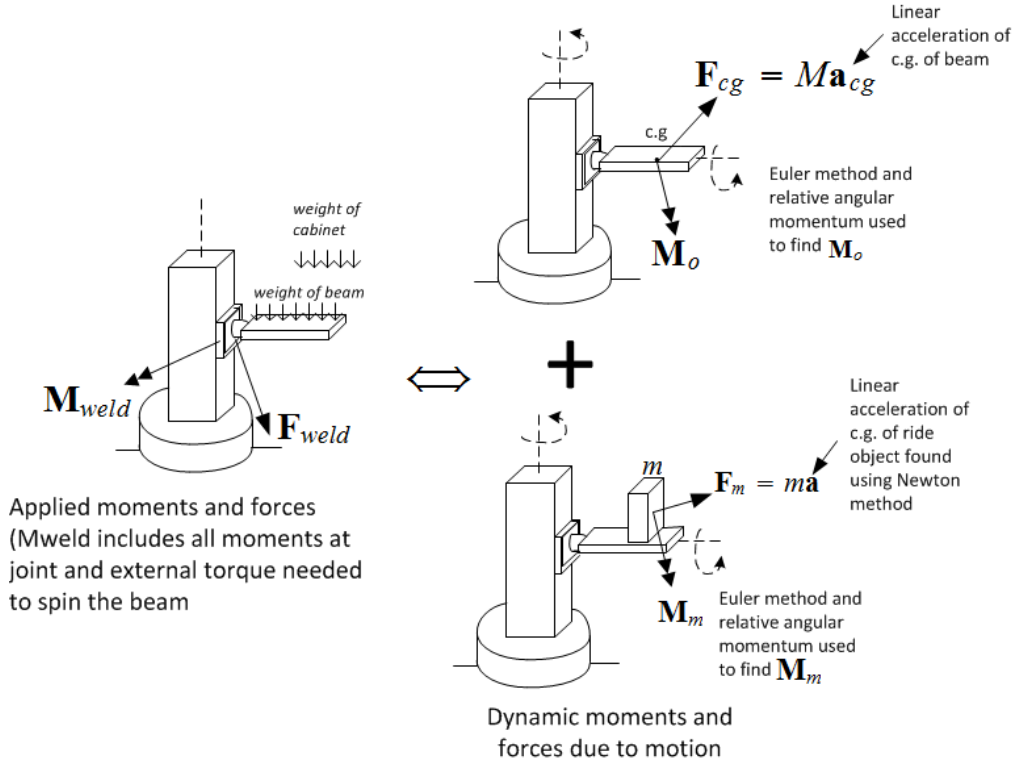

Figure 8: Beam dynamics. Balancing dynamic forces to external forces and reactions

After  $M_{weld}$  and  $F_{weld}$  are solved for, they are used (with negative signs) as known constraint forces on the column in order to solve for the column's own constraint forces and any external loads. The free body diagram for the column is given below. The analysis below shows all five derivations. The first obtains  $\mathbf{M}_{Beam}$  (dynamic moment to rotate the beam) using Euler method. The second finds  $\mathbf{M}_{cabinet}$  (dynamic moment to rotate the cabinet) using Euler method, the third uses Newton method to find linear acceleration of center of mass  $\mathbf{F}_{cabinet}$  (dynamic force to translate the cabinet), the fourth finds the linear acceleration of the center of the beam and  $\mathbf{F}_{Beam}$  and the final derivation finds  $\mathbf{M}_{column}$  (dynamic moment to rotate the column).

### 3.3 Beam to column analysis

#### 3.3.1 Finding $\mathbf{M}_{beam}$ (beam dynamic moment)

The platform is modeled as a rectangular beam. Its principal moments of inertia are given below. Let  $\omega$  be the absolute angular velocity of the local body rotating coordinates  $x'y'z'$ . Let  $\Omega$  be the beam (the body) absolute angular velocity. Hence

$$\omega_{cs} = \omega_p \mathbf{k} + \omega_s \mathbf{j}$$

But  $\omega_{cs} = \Omega_{body}$ , therefore

$$\Omega_{body} = \omega_p \mathbf{k} + \omega_s \mathbf{j}$$

$$\Omega_{body} = \omega_p \cos \theta \mathbf{e}_3 - \omega_p \sin \theta \mathbf{e}_1 + \omega_s \mathbf{e}_2$$

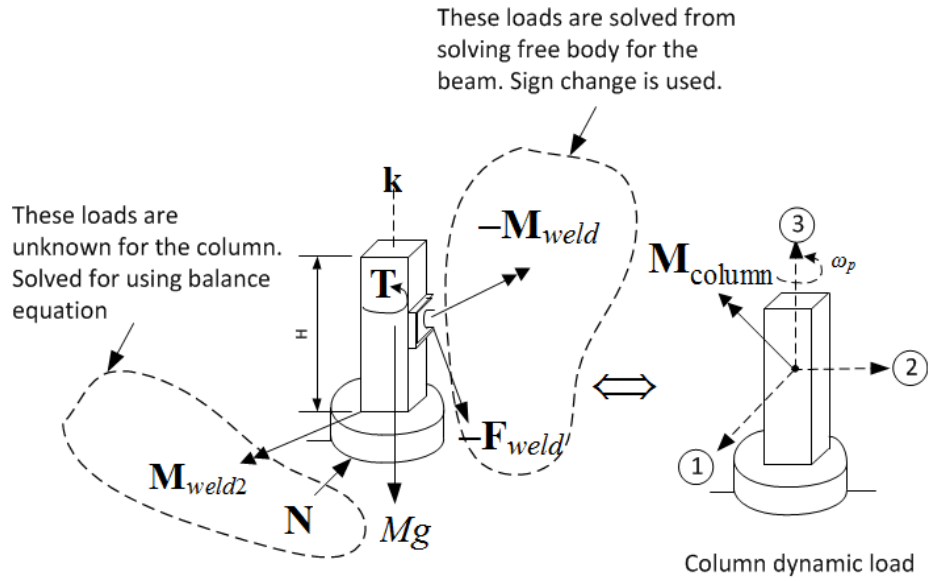

Figure 9: Column dynamics. Balance with and external loads and beam transferred loads.

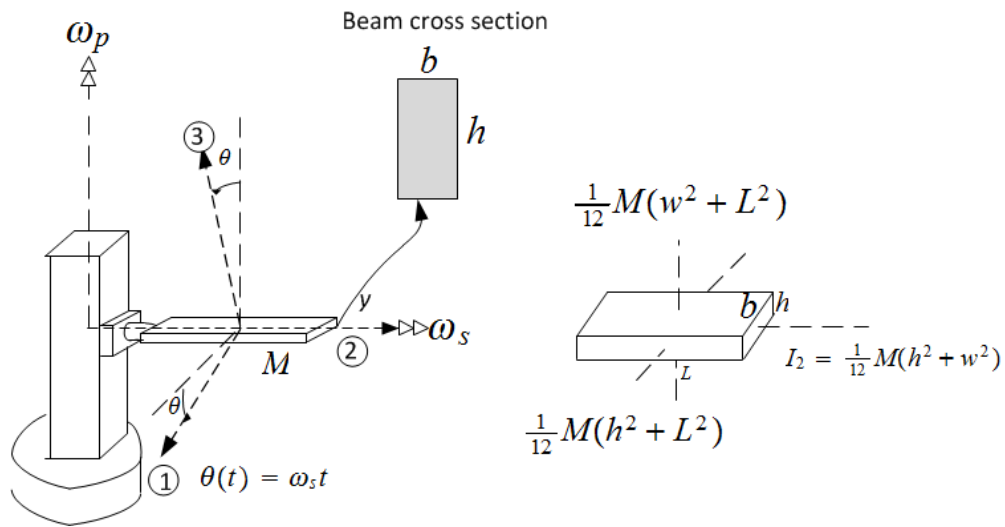

Figure 10: Configuration used for finding torque and force at beam/column joint

In component form

$$\Omega_1 = -\omega_p \sin \theta$$

$$\Omega_2 = \omega_s$$

$$\Omega_3 = \omega_p \cos \theta$$

Taking time derivative

$$\begin{aligned}\dot{\boldsymbol{\Omega}} &= \left(\dot{\boldsymbol{\Omega}}\right)_r \\ &= -(\dot{\omega}_p \sin \theta + \omega_p \omega_s \cos \theta) \mathbf{e}_1 + \dot{\omega}_s \mathbf{e}_2 + (\dot{\omega}_p \cos \theta - \omega_p \omega_s \sin \theta) \mathbf{e}_3\end{aligned}$$

In component form

$$\begin{aligned}\dot{\Omega}_1 &= -\dot{\omega}_p \sin \theta - \omega_p \omega_s \cos \theta \\ \dot{\Omega}_2 &= \dot{\omega}_s \\ \dot{\Omega}_3 &= \dot{\omega}_p \cos \theta - \omega_p \omega_s \sin \theta\end{aligned}$$

The moments of inertia of the beam using its principal axes at the center or mass are

$$\begin{aligned}I_1 &= \frac{1}{12} M (h^2 + L^2) \\ I_2 &= \frac{1}{12} M (h^2 + b^2) \\ I_3 &= \frac{1}{12} M (b^2 + L^2)\end{aligned}$$

Since  $\rho_c = 0$  (center of mass is used as reference point) then

$$M \rho_c \times \ddot{\mathbf{r}}_p = 0$$

Moments of inertia cross products are all zero since principal axes is used. The relative angular momentum of the beam becomes

$$\mathbf{h}_p = \begin{pmatrix} I_1 & 0 & 0 \\ 0 & I_2 & 0 \\ 0 & 0 & I_3 \end{pmatrix} \begin{pmatrix} \Omega_1 \\ \Omega_2 \\ \Omega_3 \end{pmatrix}$$

The rate of change of the relative angular momentum of the beam using Euler equations is

$$\dot{\mathbf{h}}_p = \begin{pmatrix} \dot{h}_1 \\ \dot{h}_2 \\ \dot{h}_3 \end{pmatrix} = \begin{pmatrix} I_1 \dot{\Omega}_1 + \Omega_2 \Omega_3 (I_3 - I_2) \\ I_2 \dot{\Omega}_2 + \Omega_1 \Omega_3 (I_1 - I_3) \\ I_3 \dot{\Omega}_3 + \Omega_1 \Omega_2 (I_2 - I_1) \end{pmatrix}$$

Therefore, the moment needed to rotate the beam with the angular velocity specified is

$$\mathbf{M}_p = \dot{\mathbf{h}}_p$$

The above components are expressed using in the beam body fixed coordinates system  $x'y'z'$  (which is the same as  $e_1, e_2, e_3$  in this case). These are converted back to the  $xyz$  coordinates system using the following transformation

$$\begin{aligned}\mathbf{M}_x &= \mathbf{M}_{p1} \cos \theta + \mathbf{M}_{p3} \sin \theta \\ \mathbf{M}_y &= \mathbf{M}_{p2} \\ \mathbf{M}_z &= -\mathbf{M}_{p1} \sin \theta + \mathbf{M}_{p3} \cos \theta\end{aligned}$$

### 3.3.2 Finding $\mathbf{M}_{\text{col}}$ (column dynamic moment)

The main support column has one degree of freedom as it only spins around its  $z$  axes with angular velocity  $\omega_p$ . Its center of mass does not translate in space. The column has a square cross section. Its height and sectional area were fixed in the design to allow changing the beam and cabinet parameters freely and see the effect on the joint stresses between the beam and the column as the failure point in the design was considered to be the the joint between the beam and the column This is a case of one body rotating around its own axes. Therefore,

$$\mathbf{M}_z = I_3 \dot{\omega}_p$$



$$I_3 = \frac{1}{12} m_{\text{col}}(2r^2)$$

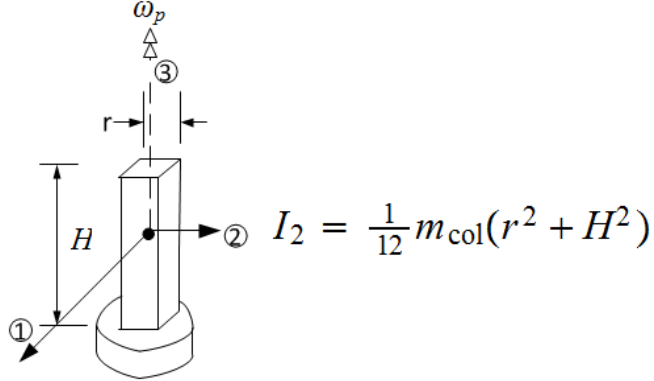

$$I_1 = \frac{1}{12} m_{\text{col}}(r^2 + H^2)$$

Where

$$\begin{aligned} I_3 &= \frac{1}{12} m_{\text{col}}(2r^2) \\ &= \frac{1}{6} m_{\text{col}} r^2 \end{aligned}$$

Where  $m_{\text{col}}$  is the mass of the column. Hence

$$M_{\text{column}} = \frac{1}{6} M r^2 \dot{\omega}_p$$

### 3.3.3 Finding $M_{\text{cabinet}}$ (cabinet dynamic moment)

The passengers including the cabinet are modeled as solid cube rigid body. The cabinet and the beam rotate with the same absolute angular velocity and act as one solid body. They were analyzed separately as it is easier to find the moment of inertias of each body separately than if both were combined.

The center of mass of the cabinet is at a distance  $\frac{h}{2}$  above the beam where  $h$  is the width of cube which is the same as the beam width. Since the cabinet is attached to the platform and is a rigid body as well, the same exact analysis that was made to the beam above can be used for the cabinet. The only difference is that the moments of inertia  $I_1, I_2, I_3$  are different. In this case they are

$$I_1 = I_2 = I_3 = \frac{1}{12} m (b^2 + h^2)$$

Therefore, the body dynamic moments are

$$\mathbf{M}_1 = I_1 \dot{\Omega}_1 + \Omega_2 \Omega_3 (I_3 - I_2)$$

$$\mathbf{M}_2 = I_2 \dot{\Omega}_2 + \Omega_1 \Omega_3 (I_1 - I_3)$$

$$\mathbf{M}_3 = I_3 \dot{\Omega}_3 + \Omega_1 \Omega_2 (I_3 - I_2)$$

The above components are expressed using the cabinet own principal axes coordinates system  $x'y'z'$  (local body coordinate systems) which is its principal axes in this case. These are converted back to the  $xyz$  coordinates using the same transformation used for the beam

$$\mathbf{M}_x = \mathbf{M}_1 \cos \theta + \mathbf{M}_3 \sin \theta$$

$$\mathbf{M}_y = \mathbf{M}_2$$

$$\mathbf{M}_z = -\mathbf{M}_1 \sin \theta + \mathbf{M}_3 \cos \theta$$

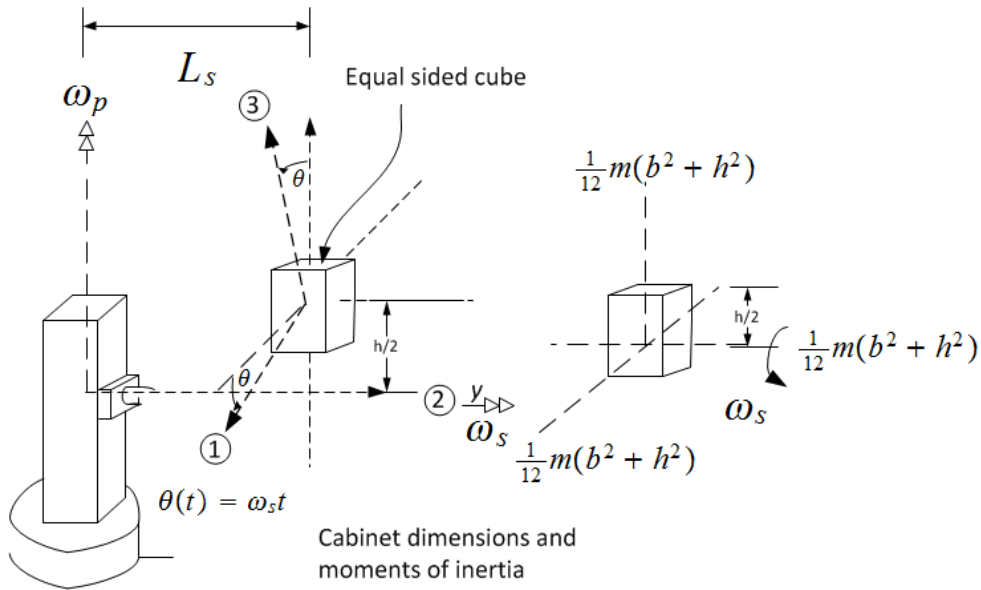

**3.3.4 Finding  $F_{cabinet}$  (cabinet dynamic linear force)**

To find  $F_m = ma$  for the cabinet, Newton method is used as follows The rotating coordinates system  $xyz$

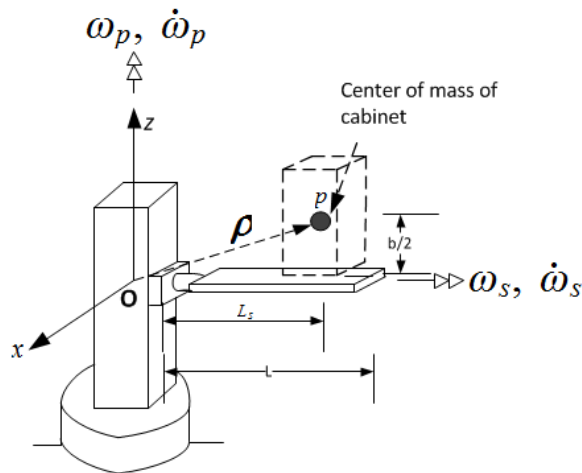

**Figure 11:** Rotating coordinates system  $xyz$  used to find passenger acceleration

has its origin at the beam column joint.  $xyz$  is attached to the column and rotates with the column with angular velocity  $\omega_p \mathbf{k}$ . The center of mass of the cabinet shown above as the circle  $p$ , is at distance  $L_s$  from the origin  $O$ .

All calculations are expressed using unit vectors of the rotating coordinates system and are valid for all time. In the rotating coordinates system, point  $p$ , the center of mass of cabinet, appears as shown in the following diagram. In this diagram  $\theta$  is the angle  $p$  makes with the  $z$  axes, where  $\theta = \omega_s t$  and  $\dot{\theta} = \omega_s$ . Using the above diagrams, the absolute velocity of  $p$  is found as follows

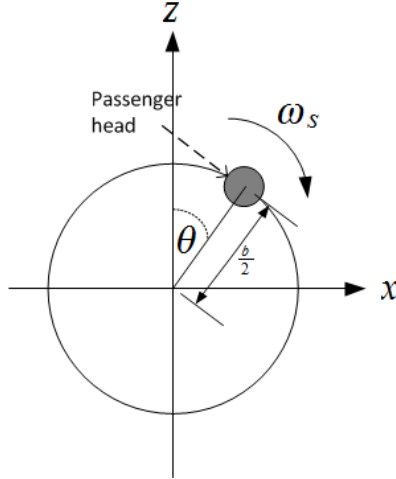

**Figure 12:** View of passenger head in the rotating coordinates system  $xyz$

$$\begin{aligned}\rho &= L_s \mathbf{j} + \frac{b}{2} \sin \theta \mathbf{i} + \frac{b}{2} \cos \theta \mathbf{k} \\ \dot{\rho}_r &= \frac{b}{2} \omega_s \cos \theta \mathbf{i} - \frac{b}{2} \omega_s \sin \theta \mathbf{k} \\ \dot{\mathbf{R}} &= 0 \\ \omega &= \omega_p \mathbf{k} \\ \omega \times \rho &= -\omega_p L_s \mathbf{i} + \omega_p \frac{b}{2} \sin \theta \mathbf{j}\end{aligned}$$

Hence the absolute velocity of  $p$  is

$$\begin{aligned}\mathbf{V} &= \dot{\mathbf{R}} + \dot{\rho}_r + \omega \times \rho \\ &= \left( \frac{b}{2} \omega_s \cos \theta \mathbf{i} - \frac{b}{2} \omega_s \sin \theta \mathbf{k} \right) - \omega_p L_s \mathbf{i} + \omega_p \frac{b}{2} \sin \theta \mathbf{j} \\ &= \left( \frac{b}{2} \omega_s \cos \theta - \omega_p L_s \right) \mathbf{i} + \omega_p \frac{b}{2} \sin \theta \mathbf{j} - \frac{b}{2} \omega_s \sin \theta \mathbf{k}\end{aligned}$$

The absolute acceleration of  $p$  is found from

$$\begin{aligned}\ddot{\rho}_r &= \left( \frac{b}{2} \dot{\omega}_s \cos \theta - \frac{b}{2} \omega_s^2 \sin \theta \right) \mathbf{i} - \left( \frac{b}{2} \dot{\omega}_s \sin \theta + \frac{b}{2} \omega_s^2 \cos \theta \right) \mathbf{k} \\ \ddot{\mathbf{R}} &= 0 \\ \dot{\omega} &= \dot{\omega}_p \mathbf{k} \\ \omega \times (\omega \times \rho) &= \omega_p \mathbf{k} \times \left( -\omega_p L_s \mathbf{i} + \omega_p \frac{b}{2} \sin \theta \mathbf{j} \right) = -\omega_p^2 L_s \mathbf{j} - \omega_p^2 \frac{b}{2} \sin \theta \mathbf{i} \\ \omega \times \dot{\rho}_r &= \omega_p \mathbf{k} \times \left( \frac{b}{2} \omega_s \cos \theta \mathbf{i} - \frac{b}{2} \omega_s \sin \theta \mathbf{k} \right) = \frac{b}{2} \omega_p \omega_s \cos \theta \mathbf{j} \\ \dot{\omega} \times \rho &= \dot{\omega}_p \mathbf{k} \times \left( L_s \mathbf{j} + \frac{b}{2} \sin \theta \mathbf{i} + \frac{b}{2} \cos \theta \mathbf{k} \right) = -\dot{\omega}_p L_s \mathbf{i} + \dot{\omega}_p \frac{b}{2} \sin \theta \mathbf{j}\end{aligned}$$

Therefore the absolute acceleration of the passenger is

$$\begin{aligned}\mathbf{a} &= \ddot{\mathbf{R}} + \ddot{\boldsymbol{\rho}}_r + 2(\boldsymbol{\omega} \times \dot{\boldsymbol{\rho}}_r) + (\dot{\boldsymbol{\omega}} \times \boldsymbol{\rho}) + \boldsymbol{\omega} \times (\boldsymbol{\omega} \times \boldsymbol{\rho}) \\ &= \left(\frac{b}{2}\dot{\omega}_s \cos \theta - \frac{b}{2}\omega_s^2 \sin \theta\right) \mathbf{i} - \left(\frac{b}{2}\dot{\omega}_s \sin \theta + \frac{b}{2}\omega_s^2 \cos \theta\right) \mathbf{k} \\ &\quad + \left(2\frac{b}{2}\omega_p\omega_s \cos \theta \mathbf{j}\right) + \left(-\dot{\omega}_p L_s \mathbf{i} + \dot{\omega}_p \frac{b}{2} \sin \theta \mathbf{j}\right) - \left(\omega_p^2 L_s \mathbf{j} + \omega_p^2 \frac{b}{2} \sin \theta \mathbf{i}\right)\end{aligned}$$

Simplifying gives

$$\begin{aligned}\mathbf{F}_{cabinet} &= m\mathbf{a} \\ &= \mathbf{i} \left(\frac{b}{2}\dot{\omega}_s \cos \theta - \frac{b}{2}\omega_s^2 \sin \theta - \dot{\omega}_p L_s - \omega_p^2 \frac{b}{2} \sin \theta\right) m \\ &\quad + \mathbf{j} \left(b\omega_p\omega_s \cos \theta + \dot{\omega}_p \frac{b}{2} \sin \theta - \omega_p^2 L_s\right) m \\ &\quad - \mathbf{k} \left(\frac{b}{2}\dot{\omega}_s \sin \theta + \frac{b}{2}\omega_s^2 \cos \theta\right) m\end{aligned}$$

The above is expressed using the common  $xyz$  rotating coordinate system

### 3.3.5 Finding $\mathbf{F}_{beam}$ (beam dynamic translational force)

The linear acceleration of the center of mass of platform, which is located at distance  $\frac{L}{2}$  from the origin  $o$  of the  $xyz$  rotating coordinates system. Therefore

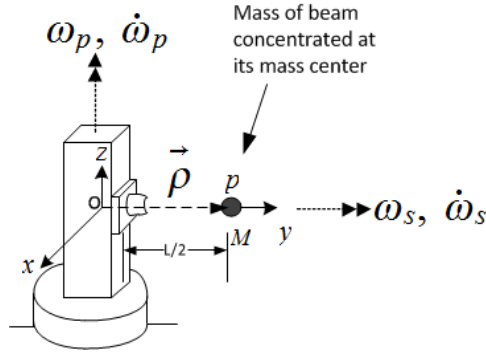

Figure 13: Rotating coordinates system  $xyz$  used to find beam center of mass acceleration

$$\begin{aligned}\boldsymbol{\rho} &= \frac{L}{2}\mathbf{j} \\ \boldsymbol{\omega} &= \omega_p\mathbf{k} \\ \boldsymbol{\omega} \times \boldsymbol{\rho} &= -\omega_p \frac{L}{2}\mathbf{i} \\ \dot{\boldsymbol{\rho}}_r &= 0 \\ \ddot{\mathbf{R}} &= 0 \\ \dot{\boldsymbol{\omega}} &= \dot{\omega}_p\mathbf{k} \\ \dot{\boldsymbol{\omega}} \times \boldsymbol{\rho} &= \dot{\omega}_p\mathbf{k} \times \frac{L}{2}\mathbf{j} = -\dot{\omega}_p \frac{L}{2}\mathbf{i} \\ \boldsymbol{\omega} \times (\boldsymbol{\omega} \times \boldsymbol{\rho}) &= \omega_p\mathbf{k} \times \left(-\omega_p \frac{L}{2}\mathbf{i}\right) = -\omega_p^2 \frac{L}{2}\mathbf{j}\end{aligned}$$

Hence

$$\begin{aligned}\mathbf{a}_{cg} &= \ddot{\mathbf{R}} + \ddot{\rho}_r + 2(\boldsymbol{\omega} \times \dot{\rho}_r) + (\dot{\boldsymbol{\omega}} \times \boldsymbol{\rho}) + \boldsymbol{\omega} \times (\boldsymbol{\omega} \times \boldsymbol{\rho}) \\ &= -\dot{\omega}_p \frac{L}{2} \mathbf{i} - \omega_p^2 \frac{L}{2} \mathbf{j}\end{aligned}$$

Therefore

$$\begin{aligned}\mathbf{F}_{beam} &= M\mathbf{a}_{cg} \\ &= -M\frac{L}{2}\dot{\omega}_p\mathbf{i} - M\frac{L}{2}\omega_p^2\mathbf{j}\end{aligned}$$

The above is expressed using the  $xyz$  rotating coordinates system.

### 3.3.6 Using free body diagram and solving for constraint forces

The dynamic forces have been found from above. They are balanced with constraint forces and any external loads using free body diagram. The following diagram shows the balance between dynamic forces and moments and external forces.  $\mathbf{M}_{weld}$  below is used to represent all constraint moments at the joint between the beam and the column, including the extra torque needed to rotate the beam. Taking moments at

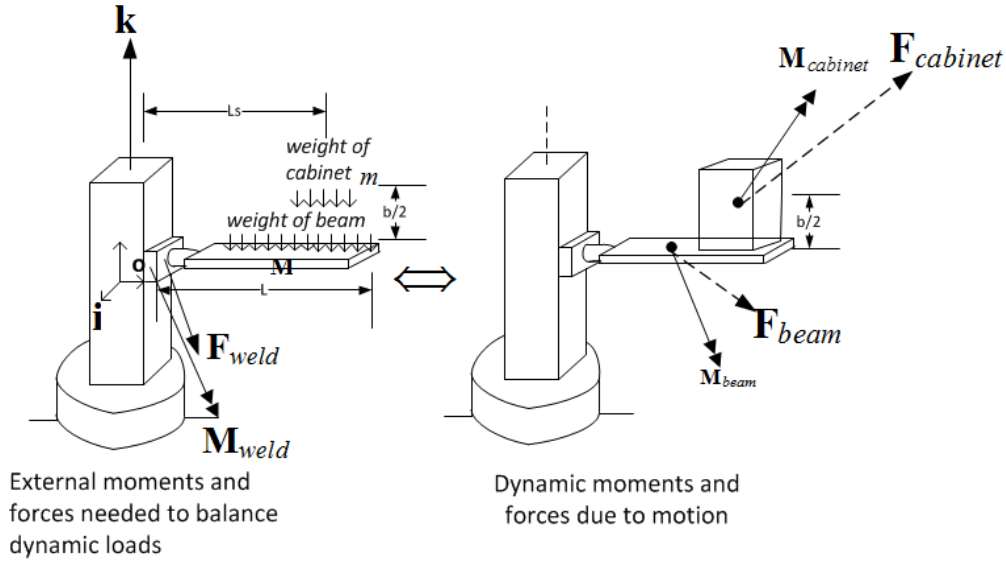

point  $o$ , the left end of the beam which is the origin of the rotating coordinates system  $xyz$

$$\begin{aligned}\mathbf{M}_{weld} + \left(\frac{L}{2}\mathbf{j} \times -Mg\mathbf{k}\right) + \left(\left(L_s\mathbf{j} + \frac{b}{2}\mathbf{k}\right) \times -mg\mathbf{k}\right) &= \mathbf{M}_{beam} + \mathbf{M}_{cabinet} + \left(\frac{L}{2}\mathbf{j} \times \mathbf{F}_{beam}\right) + \left(L_s\mathbf{j} + \frac{b}{2}\mathbf{k}\right) \times \mathbf{F}_{cabinet} \\ \mathbf{M}_{weld} - \frac{L}{2}Mg\mathbf{i} - L_smg\mathbf{i} &= \mathbf{M}_{beam} + \mathbf{M}_{cabinet} + \left(\frac{L}{2}\mathbf{j} \times \mathbf{F}_{beam}\right) + \left(L_s\mathbf{j} + \frac{b}{2}\mathbf{k}\right) \times \mathbf{F}_{cabinet}\end{aligned}$$

Hence

$$\mathbf{M}_{weld} = \left(\frac{L}{2}Mg + L_smg\right)\mathbf{i} + \mathbf{M}_{beam} + \mathbf{M}_{cabinet} + \left(\frac{L}{2}\mathbf{j} \times \mathbf{F}_{beam}\right) + \left(L_s\mathbf{j} + \frac{b}{2}\mathbf{k}\right) \times \mathbf{F}_{cabinet}$$

The force vector at the joint is

$$\begin{aligned}\mathbf{F}_{weld} - Mg\mathbf{k} - mg\mathbf{k} &= \mathbf{F}_{beam} + \mathbf{F}_{cabinet} \\ \mathbf{F}_{weld} &= (Mg + mg)\mathbf{k} + \mathbf{F}_{beam} + \mathbf{F}_{cabinet}\end{aligned}$$

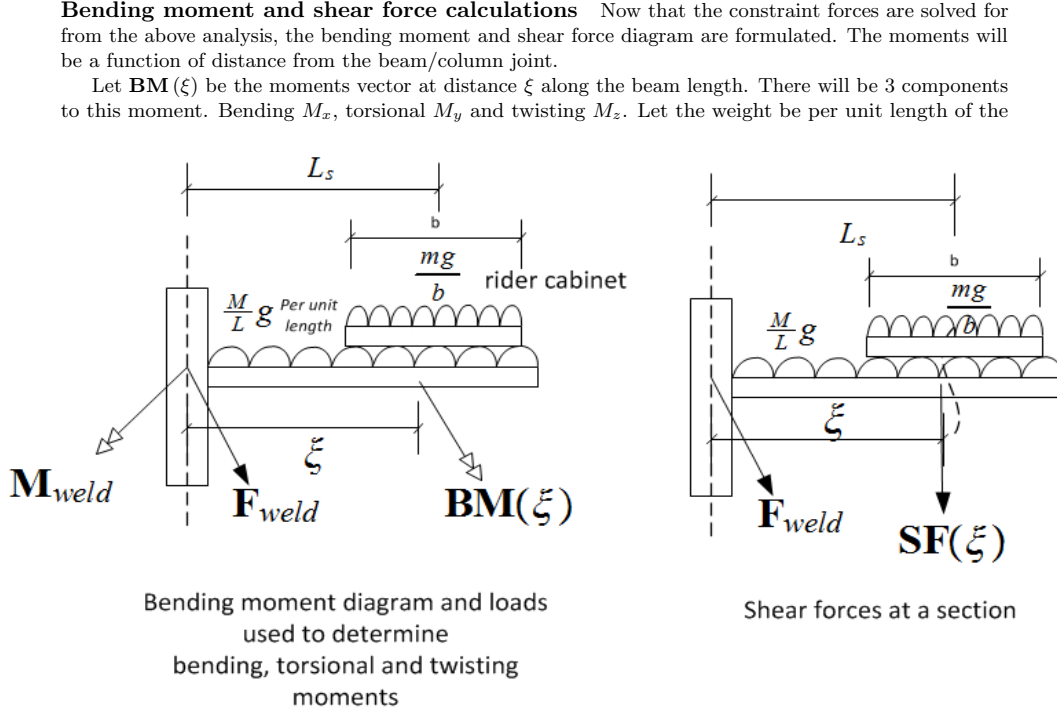

**Figure 14:** Finding the bending moment at different locations along the span of the beam

beam which is  $\frac{M}{L}g$  be  $q$ . In the following, the notation  $\langle \xi - x \rangle$  is used to indicate that the term is effective only when  $\langle \xi - x \rangle$  is positive. Let the distance to start of the cabinet be

$$\alpha = L_s - \frac{b}{2}$$

Where  $b$  is the width of the cabinet.

$$\mathbf{BM}(\xi) = \mathbf{M}_{weld} + (\xi \mathbf{j} \times \mathbf{F}_{weld}) + \left( \frac{\xi}{2} \mathbf{j} \times -q\xi \mathbf{k} \right) + \left( \frac{\xi - \alpha}{2} \mathbf{j} \times -\frac{mg}{b} (\xi - \alpha) \mathbf{k} \right) \langle \xi - \alpha \rangle$$

In component form, the bending moment will be  $\mathbf{BM}_x(\xi)$  and The torsion moment will be  $\mathbf{BM}_y(\xi)$  and the twisting moment will be  $\mathbf{BM}_z(\xi)$ .

Let  $\mathbf{SF}(\xi)$  be the shear force vector at distance  $\xi$ . Hence

$$\mathbf{SF}(\xi) = \mathbf{F}_{weld} - q\xi \mathbf{k} - \frac{mg}{b} (\xi - \alpha) \langle \xi - \alpha \rangle \mathbf{k}$$

The above completes the mathematical derivation of the dynamics of the system. The next step is to implement this model and use simulation to validate it and design for an optimal set of parameters.

**Finding shear and direct stress from bending and shear forces** The result of the above calculations is the moments and forces at the joint between the beam and the column and using  $\mathbf{BM}(\xi)$  and  $\mathbf{SF}(\xi)$  at any other section in the beam.

The next step is to use these to obtain complete description of stress state at the section. Due to lack of time finite element analysis was not performed. Therefore, basic beam theory equations were used for stress calculation. Care was taken to insure that the beam cross section selected had thickness not less than its width. Having a thin beam would require analysis using plate theory making it much more complicated. The disadvantages of this method is that the beam was much heavier than needed if thin beam was used, but the advantage is that the stress equations used are known to be valid in this case.

Given the moments  $M_x, M_y, M_z$  and the forces  $F_x, F_y, F_z$  all the cross section, the following equations were used. These equations assume a rectangle beam cross section of thickness  $h$  and width  $b$  and that  $h \geq b$

$$\sigma_{\max} = \frac{M_x c}{I_{area}} = \frac{M_x \frac{h}{2}}{\frac{1}{12} b h^3}$$

$$\tau_{\max} = \frac{3V_{\max}}{2A}$$

Torsional stress was not fully developed in this design since it is a rectangular cross section and would require finite element analysis. The beam is expected to fail due to bending moment  $M_x$  and this is what the rest of the analysis address. Future analysis of stress concentration will use finite element analysis and will take torsion stress into account.

### 3.4 Column dynamic analysis

In the above section the constraint forces in the beam/column joints were found. These are now used as external forces on the column with an opposite sign. Free body diagram is used for the column in order to find the constraint forces and external loads acting on the column. The following diagram shows the free body diagram used

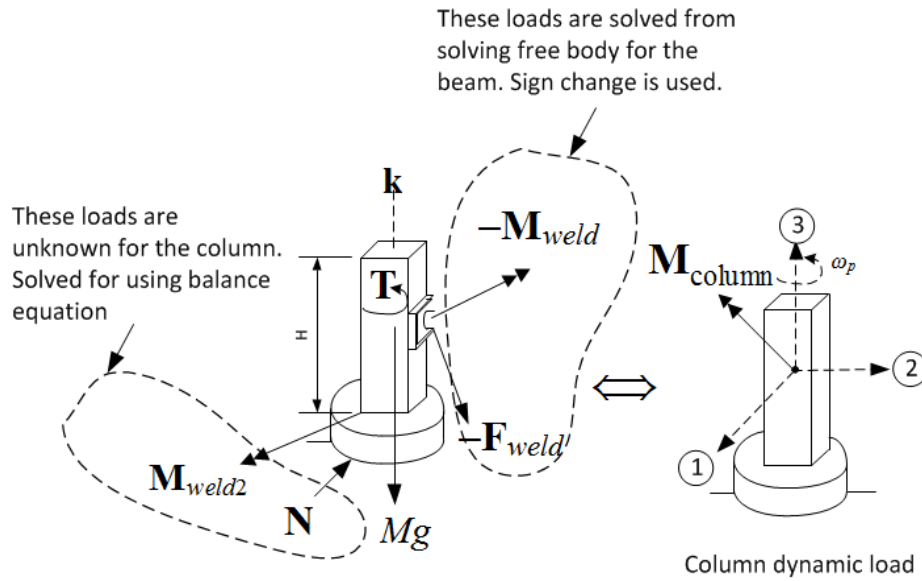

**Figure 15:** Dynamic load balance between column and external loads

Taking moments at the joint between the column and the ground

$$\mathbf{T} + \mathbf{M}_{weld2} - \mathbf{M}_{weld} + \left( -\frac{H}{2} \mathbf{k} \times -\mathbf{F}_{weld} \right) = \mathbf{M}_{column}$$

Solving for the unknown constraint force  $\mathbf{N}$  and the external torque  $\mathbf{T}$

$$\mathbf{M}_{weld2} + \mathbf{T} = \mathbf{M}_{column} - \left( \frac{H}{2} \mathbf{k} \times \mathbf{F}_{weld} \right) + \mathbf{M}_{weld}$$

The torque  $\mathbf{T}$  is unknown at this stage and has to be determined by other means to obtain complete solution. This is the external torque needed to accelerate the column during ramp up and to decelerate it during ramp down phases. Combining all the unknowns into one term called  $\mathbf{M}_{weld3}$ , the above reduces to

$$\mathbf{M}_{weld3} = \mathbf{M}_{column} - \left( \frac{H}{2} \mathbf{k} \times \mathbf{F}_{weld} \right) + \mathbf{M}_{weld}$$

The balance equation for forces gives

$$\mathbf{N} - Mg\mathbf{k} - \mathbf{F}_{weld} = 0$$
$$\mathbf{N} = Mg\mathbf{k} + \mathbf{F}_{weld}$$

Now that all loads acting on the column are found, bending moment and shear force diagrams can be also be made or finite element analysis used in order to determine the stress state inside the column at every section.



## 4 Simulation of the dynamic equations found

### 4.1 Review of the simulation

The simulation accepts as input all the parameters shown in table 1 on page 11. The goal of the simulation is to verify visually the dynamics and to allow the selection of correct sizes for the structure and to insure that the acceleration does not exceed  $6g$  using the selected parameters. Based on the simulation, one optimal set of values was selected and given in the conclusion section. The simulator displays tables showing all the current values for stress and moments found at the beam/column joint. It keeps track of the maximum stress values reached and uses these to determine the maximum stress using the equations shown above.

This diagram shows an overview of the user interface. This software can be run from the project web site located at [http://12000.org/my\\_notes/mma\\_demos/EMA542\\_project/index.htm](http://12000.org/my_notes/mma_demos/EMA542_project/index.htm)

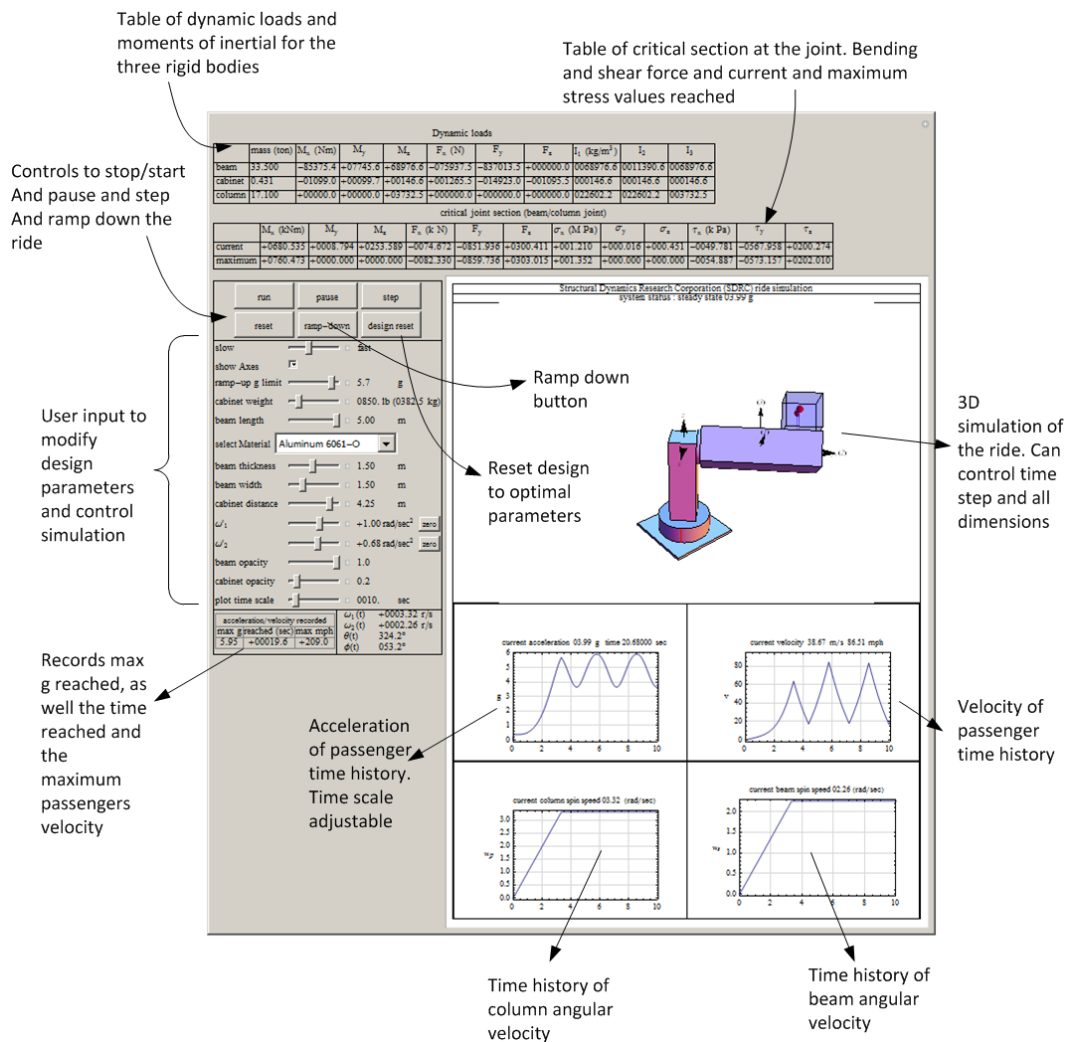

Figure 16: overview of simulator user interface

### 4.2 Simulation output, time histories and discussion of results

All these tables and results below are generated from the final design using the selected final optimal parameters.

Dynamic loads

	mass (ton)	$M_x$ (Nm)	$M_y$	$M_z$	$F_x$ (N)	$F_y$	$F_z$	$I_1$ (kg/m <sup>3</sup> )	$I_2$	$I_3$
beam	10.400	-32963.4	+01417.5	+02086.9	-003307.5	-076914.6	+000000.0	0010434.4	0001575.0	0010434.4
cabinet	0.279	-00882.5	+00038.0	+00008.4	-000616.9	+001760.5	-011906.4	000042.2	000042.2	000042.2
column	17.100	+00000.0	+00000.0	+00746.5	+000000.0	+000000.0	+000000.0	022602.2	022602.2	003732.5

Figure 17: dynamic loads at the end of ride using optimal design values

critical joint section (beam/column joint)

	$M_x$ (kNm)	$M_y$	$M_z$	$F_x$ (k N)	$F_y$	$F_z$	$\sigma_x$ (M Pa)	$\sigma_y$	$\sigma_z$	$\tau_x$ (k Pa)	$\tau_y$	$\tau_z$
current	+0099.060	+0001.147	+0009.734	-0003.924	-0075.154	+0083.183	+000.594	+000.007	+000.058	-0005.887	-0112.731	+0124.774
maximum	+0175.814	+0007.630	+0009.734	-0015.955	-0085.740	+0107.003	+001.055	+000.046	+000.058	-0023.932	-0128.610	+0160.505

Maximum direct stress was due to pending moment. Remained Well below the yield stress for Aluminum

Figure 18: critical section current and maximum moments and stresses

Guard limit found by trial used to stop the acceleration at. (passenger acceleration will reach the 6g using this but not exceed)

Optimal parameters found by simulation

Figure 19: optimal set of parameters obtained from simulation.

acceleration/velocity recorded		
max g	reached (sec)	max mph
5.98	+00012.1	+187.0

Figure 20: simulator keeps track of maximum  $g$  felt by passenger to insure it does not exceed  $6g$

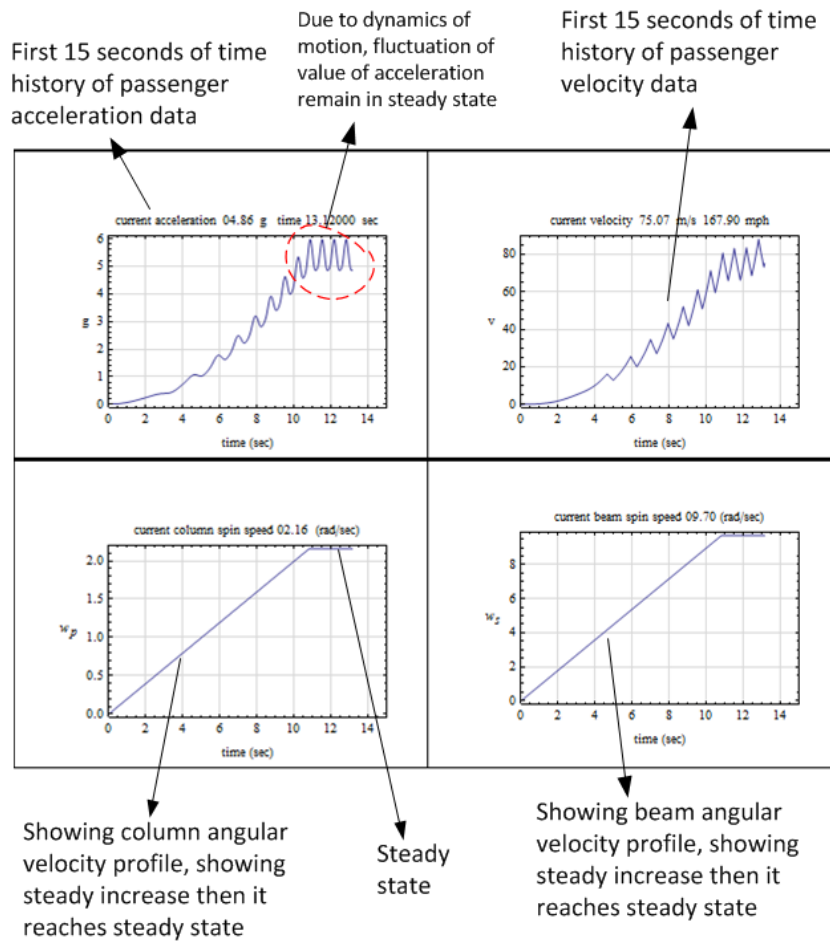
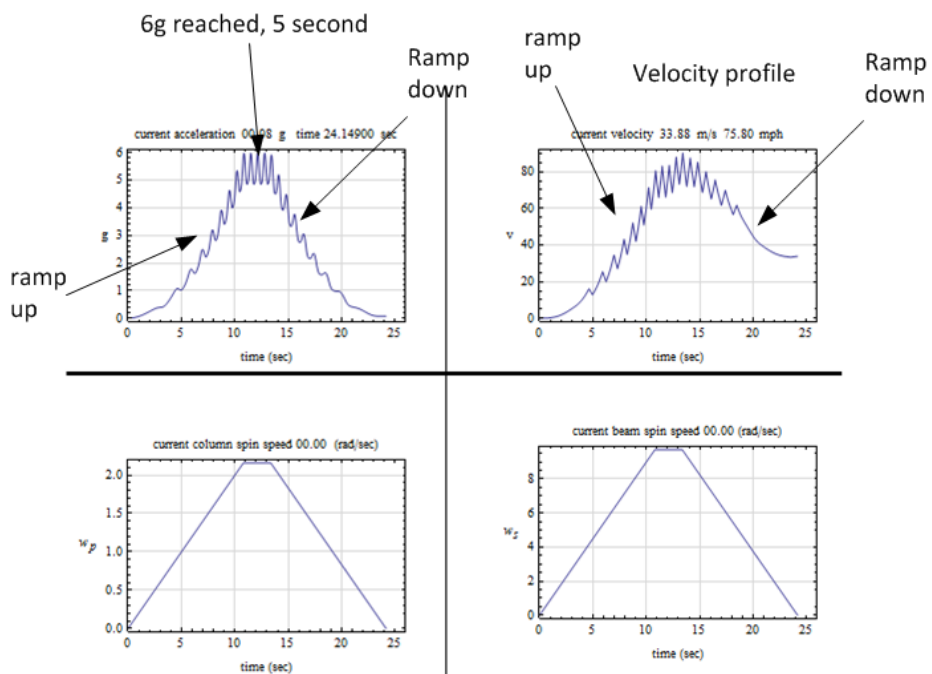

Figure 21: acceleration and velocity of passenger time history and angular velocity time history of beam and column



Column and beam angular velocities time histories shown effect of ramp down

Figure 22: time histories using the ramp down option used after reaching 6g goal

### 4.3 Discussion and analysis of results

The following table gives the optimal design parameters found by simulation of the derived model in order to achieve the customer requirements.

parameter	value	description
beam mass	10.4 ton	one ton is 2000 lbs
beam width	1 meters	
beam thickness	1 meters	
beam length	3.5 meters	
cabinet mass	560 lbs	includes 2 passengers, seating, frame and factor of safety
cabinet height	1 meters	
cabinet width	1 meters	
column mass	17.1 ton	
column cross section	3 by 3 meters	
maximum bending moment $M_x$	175 KNm	
maximum torsion moment $M_y$	7.6 KNm	
maximum twisting moment $M_z$	28 KNm	
maximum shear force $F_x$	-15.96 KN	
maximum shear force $F_y$	-85 KN	
maximum shear force $F_z$	107 KN	
maximum direct stress $\sigma_x$	1.055 MPa	Below tensile yield. Pure Aluminium has 10 MPa. and
maximum direct stress $\sigma_y$	0.046 MPa	Aluminium 6061-O yields at 200 MPa.
maximum direct stress $\sigma_z$	0.172 MPa	
maximum shear stress $\tau_x$	-23.94 KPa	
maximum shear stress $\tau_y$	-128.6 KPa	
maximum shear stress $\tau_z$	150.5 KPa	

**Table 3:** design output for loading and forces using optimal parameters found

It was found that in order to be able to achieve the 6g limit and not exceed it, the acceleration have to put turned off well before the 6g is detected. This can be seen by examining the passenger acceleration expression from above, which is

$$\begin{aligned} \mathbf{a} = & \mathbf{i} \left( \frac{b}{2} \dot{\omega}_s \cos \theta - \frac{b}{2} \omega_s^2 \sin \theta - \dot{\omega}_p L_s - \omega_p^2 \frac{b}{2} \sin \theta \right) \\ & + \mathbf{j} \left( 2 \frac{b}{2} \omega_p \omega_s \cos \theta + \dot{\omega}_p \frac{b}{2} \sin \theta - \omega_p^2 L_s \right) \\ & + \mathbf{k} \left( -\frac{b}{2} \dot{\omega}_s \sin \theta - \frac{b}{2} \omega_s^2 \cos \theta \right) \end{aligned}$$



We can see that, by letting  $\dot{\omega}_s$  and  $\dot{\omega}_p$  then the acceleration becomes

$$\mathbf{a} = \mathbf{i} \left( -\frac{b}{2} \omega_s^2 \sin \theta - \omega_p^2 \frac{b}{2} \sin \theta \right) + \mathbf{j} \left( 2 \frac{b}{2} \omega_p \omega_s \cos \theta - \omega_p^2 L_s \right) - \mathbf{k} \frac{b}{2} \omega_s^2 \cos \theta$$

Even though from now on the angular velocities  $\omega_s$  and  $\omega_p$  are constant, this does not imply that  $\mathbf{a}$  will become constant. Since  $\theta$  is still changing in time, then  $\mathbf{a}$  will still fluctuate in periodic fashion from now on. Hence the passenger acceleration can still exceed 6g if we were to turn off the ramp up acceleration too close to 6g. For this reason the value the acceleration was turned off at 5.8g in order to final value of 5.98g as felt by the passengers.

#### 4.4 Cost analysis

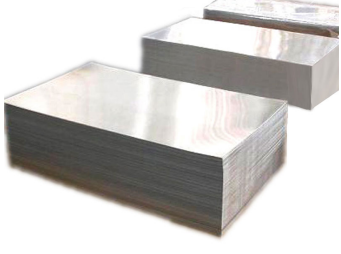
Based on the above result and using the mass needed, the following table gives a summary of cost for construction of the ride

item	cost	description
cost of Aluminum alloy 6061-O	\$0.8 per lb.	can depend on market conditions
beam material cost (10.4 ton)	\$16,000	(10.4) (2000) (0.8)
column material cost (17.1 ton)	\$27,360	(17.1) (2000) (0.8)
		
cabinet material cost (500 lb.)	\$446.5	
Labor cost for construction	\$12,000	300 labor hrs @ 40 per hr.
Equipment and labor insurance	\$10,000	
Management cost (one manager)	\$4,000	50 hrs @ \$80 per hr.
		
Electric spindle motors for column and beam	\$10,000	2 @ \$5,000
Total cost	<b>\$79,806</b>	

**Table 4:** cost estimate

The major part of the cost is for material. This is due to the use of thick beam and column. This allowed the use of basic beam theory stress analysis. This cost however can be reduced by the use of plate theory or numerical finite elements methods in order to be able to safely used less material and reduce the thickness of the beam and column while insuring accurate stress calculations.

## 5 Conclusions of results and future work

The final design given above meets the requirement specification that the customer provided. Using simulation, it was possible to validate the equations found and to confirm that the beam/column section is safe for the selected optimal parameters.

The selected parameters allow the passengers to reach almost  $6g$  in 12 seconds using a ride that consist of two noncollinear angular velocities. There are many different profiles that could have been selected to achieve this goal. The set selected reached the closest to  $6g$  without crossing over and that is why it was selected. The following is the final design used

parameter	value	description
maximum $g$ reached	5.98 g	After many simulations this was selected.
time to reach maximum $g$	5.8 sec.	
maximum passenger velocity reached	180 m.p.h.	calculated using finite difference from acceleration data
steady state $\omega_p$ reached	2.16 rad/sec.	This is the column angular velocity in steady state
steady state $\omega_s$ reached	9.7 rad/sec.	This is the beam angular velocity in steady state
initial ramp up $\dot{\omega}_p$	0.2 rad/sec. <sup>2</sup>	column supplied ramp up angular acceleration
initial ramp up $\dot{\omega}_s$	0.9 rad/sec. <sup>2</sup>	beam supplied ramp up angular acceleration
ramp down $\dot{\omega}_p$	0.2 rad/sec. <sup>2</sup>	symmetrical shape to ramp-up as seen in above plot.
ramp down $\dot{\omega}_s$	-0.9 rad/sec. <sup>2</sup>	symmetrical shape to ramp-up as seen in above plot.

**Table 5:** ride statistics based on optimal design parameters

The cost estimate is \$79,800. The material cost was the major part of this cost. This was due to the use of simple beam theory for stress analysis equations which required the use of a thick beam in order for the stress equations to be valid. The maximum stress of  $\sigma_{\max} = 1.055$  MPa reached is well below the yield strength of Aluminum. Therefore, the use of finite element stress analysis or advanced plate theory would have allowed the reduction of the size of the beam while at the same time using accurate stress calculations. This would have resulted in lower cost in material. If awarded this contract, finite element would be used in order to lower the cost of material.

### 5.1 Future work and possible design improvement

The following are items that can be improved in the current design given additional time to perform

1. The beam and column weight can be reduced significantly by using plate shell stress analysis. This should reduce the material cost. This design used simple beam theory stress analysis which required the use of thick beam. This caused the beam to become too thick. It will be possible to have thinner beam and still not reach the yield strength. Using finite element method will allow this investigation.
2. There are additional possible cross sections to consider for failure analysis. This design concentrated on the most likely section based on beam theory. Using finite element software will allow one to more easily analyze the full structure more easily than was done in current design based on simple beam theory.
3. Torsional and twisting stress analysis were not addressed in this design due to time limitation. It is however expected that the beam will fail in bending.

## 6 Appendix

### 6.1 Use of simulator to validate different design parameters

These are selected screen shots showing different configurations tested during simulation in order to find an optimal one. These show the effect of changing the dimensions of the structure and the spin rates.

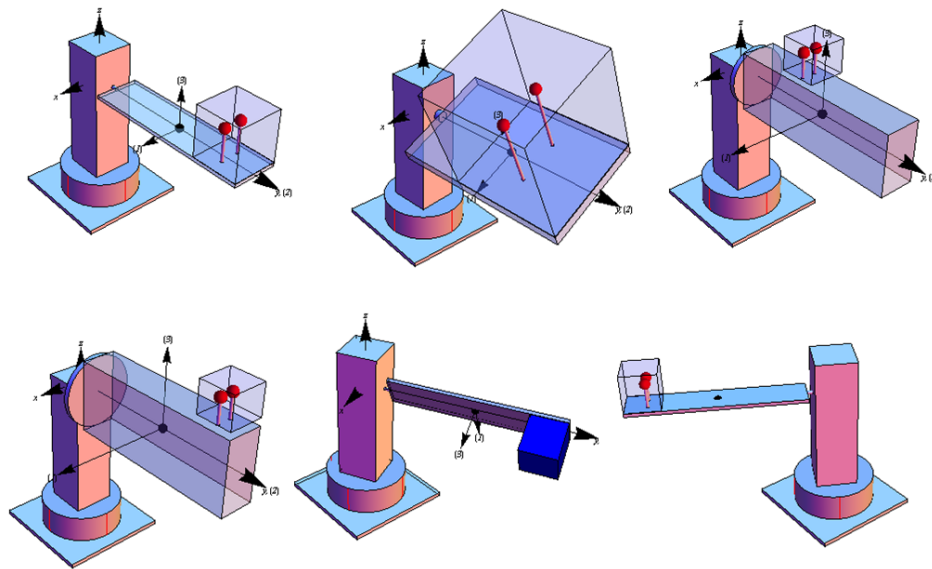

**Figure 23:** Changing the structure dimensions to select optimal design using simulation

### 6.2 References

1. Daniel C. Kammer, EMA 542 lecture notes and printed book. University of Wisconsin, Madison. 2013
2. R. C. Hibbeler. Engineering Mechanics, Dynamics. Prentice Hall, NJ 2011
3. Aluminium page at Wikipedia <http://en.wikipedia.org/wiki/Aluminium>
4. Moments of inertia page at Wikipedia [http://en.wikipedia.org/wiki/List\\_of\\_moments\\_of\\_inertia](http://en.wikipedia.org/wiki/List_of_moments_of_inertia)
5. Density of materials page <http://physics.info/density/>
6. Beam design formulas with shear and moment diagrams book, AWC council, 2007, Washington, DC.



# Chapter 3

## cheat sheets

### Local contents

3.1	First exam . . . . .	54
3.2	Second exam . . . . .	55
3.3	Final exam . . . . .	56

### 3.1 First exam

Kinematic equations  
 $s = V_i t + \frac{1}{2} a t^2$   
 $V_f = V_i + a t$   
 $s = \frac{1}{2} (V_i + V_f) t$   
 $V_f^2 = V_i^2 + 2 a s$

$$\vec{V} = \dot{R} + \dot{\rho}_r + \vec{\omega} \times \vec{\rho}$$

$$\vec{a} = \ddot{R} + \ddot{\rho}_r + 2(\vec{\omega} \times \dot{\rho}_r) + (\dot{\vec{\omega}} \times \vec{\rho}) + \vec{\omega} \times (\vec{\omega} \times \vec{\rho})$$

$\vec{\omega}$  is absolute angular velocity of rotating frame

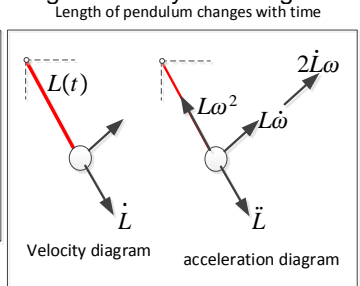
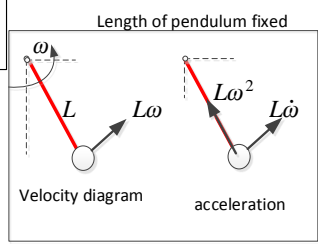
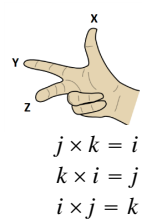
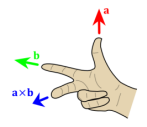
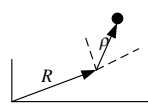

$$\cos\left(\frac{\pi}{2} - \theta\right) = \sin\theta$$

$$\cos\left(\frac{\pi}{2} + \theta\right) = -\sin\theta$$

$$\sin\left(\frac{\pi}{2} - \theta\right) = \cos\theta$$

$$\frac{d}{dx} \cos x = -\sin x$$

$$\dot{A} = \dot{A}e_A + \omega \times A$$

$$ds = \sqrt{dx^2 + dy^2}$$

$$\frac{ds}{dt} = \frac{dx}{dt} \sqrt{1 + \left(\frac{dy}{dx}\right)^2}$$

$$k = \frac{d^2y}{dx^2} \frac{1}{\left(1 + \left(\frac{dy}{dx}\right)^2\right)^{\frac{3}{2}}}$$

$\sin 2A$	$2 \sin A \cos A$
$\cos 2A$	$2 \cos^2 A - 1$
$\sin A \sin B$	$\frac{1}{2} (\cos(A - B) - \cos(A + B))$
$\cos A \cos B$	$\frac{1}{2} (\cos(A - B) + \cos(A + B))$
$\sin A \cos B$	$\frac{1}{2} (\sin(A - B) + \sin(A + B))$

$\sin(a \pm b)$	$\sin a \cos b \pm \cos a \sin b$
$\cos(a \pm b)$	$\cos a \cos b \mp \sin a \sin b$
$\sin^2 a$	$\frac{1}{2} (1 - \cos 2a)$

$$\rho = \frac{1}{k}$$

$$a = \ddot{s} e_t + \frac{\dot{s}^2}{\rho} e_n$$

$$v = \dot{s} e_t$$

$$\rho = \frac{\dot{s}^2}{|a_n|}$$

$$\dot{e}_t = \frac{\dot{s}}{\rho} e_n$$

$$\ddot{s} = a \cdot e_t$$

$$e_t = \frac{dx}{ds} i + \frac{dy}{ds} j$$

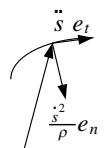

$\cos^2 a = \frac{1}{2} (1 + \cos 2a)$	$\sin(A \pm 90^\circ) = \cos A$
$\cos(a \pm 90^\circ) = \mp \sin a$	$\sin(A \pm 180^\circ) = \mp \sin A$
$\cos(a \pm 90^\circ) = \cos a$	$\cos(A \pm 180^\circ) = -\cos A$

$$r = \frac{-b \pm \sqrt{b^2 - 4ac}}{2a}$$

### 3.2 Second exam

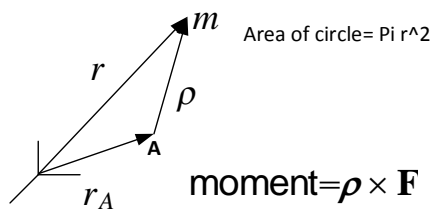

$$\vec{H}_p = \dot{\vec{h}}_p + \vec{\rho}_c \times M \ddot{\vec{r}}_p$$

$\rho_{cm}$   $\vec{r}$   $O$   $\Delta S$   $\vec{r}$   $\vec{r}_o = 0$   
 $\therefore \vec{H}_p = \dot{\vec{h}}_p = \dot{\vec{H}}_r = \dot{\vec{H}}_o$

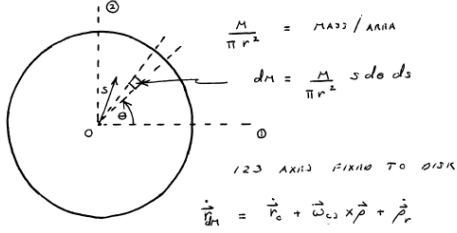

$$\dot{\vec{h}}_A = \rho \times m \dot{\vec{p}} \quad d\vec{h}_o = \rho \times \dot{\vec{p}} dm$$

$$\dot{\vec{h}}_A = \frac{d}{dt} \vec{h}_A + (\omega_{ha} \times \vec{h}_A)$$

$$M_A = \dot{\vec{h}}_A + \rho \times m \ddot{\vec{r}}_A$$

$$M_A = \dot{\vec{h}}_A + \rho_{center} \times m \ddot{\vec{r}}_A$$

Use this if A is moving. Mass center

$$x = \frac{\omega_e g t^3}{3} \cos(\lambda) + \omega_e t^2 (\dot{y}_0 \sin(\lambda) - \dot{z}_0 \cos(\lambda)) + \dot{x}_0 t + x_0$$

$$y = -\omega_e t^2 \dot{x}_0 \sin(\lambda) + \dot{y}_0 t + y_0$$

$$z = -\frac{g t^2}{2} + \dot{z}_0 t + z_0 + \omega_e \dot{x}_0 t^2 \cos(\lambda)$$

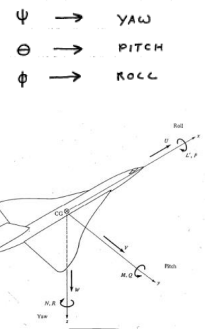
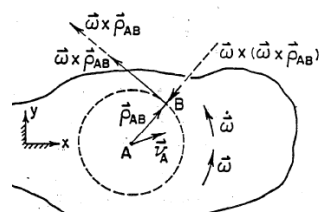
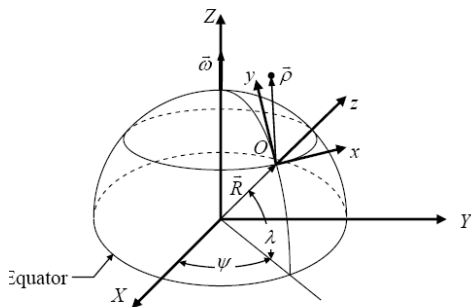
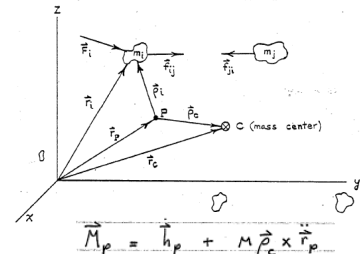

Figure 1.28: Relative reference frame for projectile

$\psi$ ,  $\theta$ , and  $\phi$  are called the angles of precession, nutation, and spin respectively.

$$\begin{bmatrix} \omega_x \\ \omega_y \\ \omega_z \end{bmatrix} = \begin{bmatrix} \sin(\theta)\sin(\phi) & \cos(\phi) & 0 \\ \sin(\theta)\cos(\phi) & -\sin(\phi) & 0 \\ \cos(\theta) & 0 & 1 \end{bmatrix} \begin{bmatrix} \dot{\psi} \\ \dot{\theta} \\ \dot{\phi} \end{bmatrix}$$

Time of flight up arm of trip = (initial speed)/g

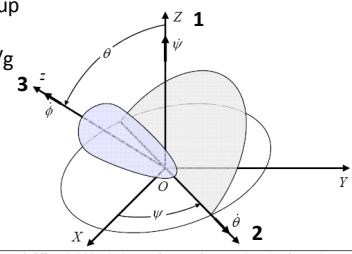
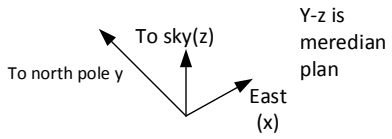

Figure 1.37: Rigid body in xyz frame after rotating the frame by Euler angles

### 3.3 Final exam

$$\begin{aligned} \mathbf{v} &= \boldsymbol{\omega} \times \mathbf{r} \\ \mathbf{a}_n &= \boldsymbol{\omega} \times \mathbf{v} = \boldsymbol{\omega} \times (\boldsymbol{\omega} \times \mathbf{r}) \\ \mathbf{a}_t &= \dot{\boldsymbol{\omega}} \times \mathbf{r} \end{aligned}$$

Angular momentum of a rigid body in plane motion

$$\begin{aligned} h_G &= \bar{I}\omega \text{ (about the mass center } G) \\ h_A &= I_A\omega \text{ (about the instant center } A \text{ for velocities)} \\ h_A &= \bar{I}\omega + m\bar{v}d \text{ (about an arbitrary point } A) \end{aligned}$$

$d$  = moment arm of the momentum vector  $m\bar{v}$  about  $A$

$$\boldsymbol{\omega} \times \mathbf{h} = \begin{vmatrix} e_1 & e_2 & e_3 \\ \omega_1 & \omega_2 & \omega_3 \\ I_1\Omega_1 & I_2\Omega_2 & I_3\Omega_3 \end{vmatrix} \boldsymbol{\omega} = \text{frame, } \Omega = \text{body}$$

$$\begin{aligned} M_x &= I_1\dot{\Omega}_1 + \Omega_2\Omega_3(I_3 - I_2) \\ M_y &= I_2\dot{\Omega}_2 + \Omega_3\Omega_1(I_1 - I_3) \\ M_z &= I_3\dot{\Omega}_3 + \Omega_1\Omega_2(I_2 - I_1) \end{aligned}$$

z-axis is symmetry

$$\begin{aligned} M_x &= I_1\dot{\Omega}_1 + I_3\omega_y\Omega_3 - I_2\omega_z\Omega_2 \\ M_y &= I_2\dot{\Omega}_2 - I_3\omega_x\Omega_3 + I_1\omega_z\Omega_1 \\ M_z &= I_3\dot{\Omega}_3 + I_2\omega_x\Omega_2 - I_1\omega_y\Omega_1 \end{aligned}$$

Use these for case 2. x-axis symmetry.  $I_{yy}=I_{zz}$

(x-axis symm)

$$\begin{aligned} M_x &= I_x(\dot{\omega}_x + \dot{n}) \\ M_y &= I_y\dot{\omega}_y + \omega_z(\omega_x + n)I_x - \omega_x\omega_z I_z - m\dot{x}_p\dot{z}_p \\ M_z &= I_z\dot{\omega}_z - \omega_y(\omega_x + n)I_x + \omega_x\omega_y I_y + m\dot{x}_p\dot{y}_p \end{aligned}$$

(y-axis symm)

$$\begin{aligned} M_y &= I_y(\dot{\omega}_y + \dot{n}) \\ M_z &= I_z\dot{\omega}_z + \omega_x(\omega_y + n)I_y - \omega_y\omega_x I_x \\ M_x &= I_x\dot{\omega}_x - \omega_z(\omega_y + n)I_y + \omega_y\omega_z I_z \end{aligned}$$

(z-axis symm)

$$\begin{aligned} M_z &= I_z(\dot{\omega}_z + \dot{n}) \\ M_x &= I_x\dot{\omega}_x + \omega_y(\omega_z + n)I_z - \omega_z\omega_y I_y \\ M_y &= I_y\dot{\omega}_y - \omega_x(\omega_z + n)I_z + \omega_z\omega_x I_x \end{aligned}$$

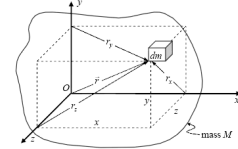
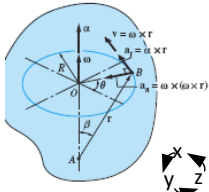
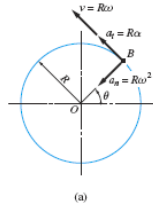

Figure A.1: System definition.

definition, the moment of inertia is

$$\begin{aligned} I_x &= \int_V r_y^2 dm = \int_V (y^2 + z^2) dm \\ I_y &= \int_V r_x^2 dm = \int_V (x^2 + z^2) dm \\ I_z &= \int_V r_z^2 dm = \int_V (x^2 + y^2) dm \end{aligned}$$

Rectangular components of angular momentum

$$h_x = I_x\omega_x - I_{xy}\omega_y - I_{xz}\omega_z$$

$$h_y = -I_{yx}\omega_x + I_y\omega_y - I_{yz}\omega_z$$

$$h_z = -I_{zx}\omega_x - I_{zy}\omega_y + I_z\omega_z$$

(About fixed point or mass center)

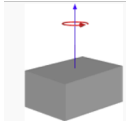

$$\begin{aligned} I_h &= \frac{1}{12}m(w^2 + d^2) \\ I_w &= \frac{1}{12}m(h^2 + d^2) \\ I_d &= \frac{1}{12}m(h^2 + w^2) \end{aligned}$$

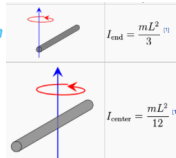

$$\begin{aligned} I_z &= \frac{mr^2}{2} \\ I_x &= I_y = \frac{mr^2}{4} \end{aligned}$$

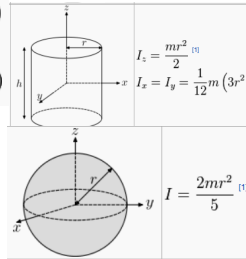

$$I = \frac{2mr^2}{5}$$

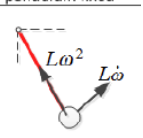
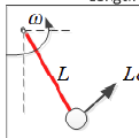

Velocity diagram

acceleration diagram

Length of pendulum changes with time

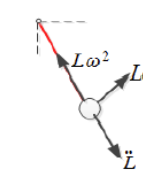
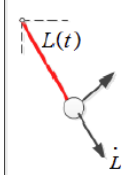

Velocity diagram

acceleration diagram

$$\begin{aligned} \sin^2 x &= \frac{1 - \cos 2x}{2} \\ \cos^2 x &= \frac{1 + \cos 2x}{2} \\ \sin 2x &= 2 \sin x \cos x \\ \cos 2x &= \cos^2 x - \sin^2 x \\ &= 1 - 2 \sin^2 x \end{aligned}$$

$$V_p = V_o + \boldsymbol{\omega} \times \mathbf{r} + V_{rel}$$

$$a_p = a_o + \dot{\boldsymbol{\omega}} \times \mathbf{r} + \boldsymbol{\omega} \times (\boldsymbol{\omega} \times \mathbf{r}) + 2\boldsymbol{\omega} \times V_{rel} + a_{rel}$$

$\sin 2A$	$2 \sin A \cos A$
$\cos 2A$	$2 \cos^2 A - 1$
$\sin A \sin B$	$\frac{1}{2} (\cos(A - B) - \cos(A + B))$
$\cos A \cos B$	$\frac{1}{2} (\cos(A - B) + \cos(A + B))$
$\sin A \cos B$	$\frac{1}{2} (\sin(A - B) + \sin(A + B))$
$h = v_i t + \frac{1}{2} g t^2$	$h = \frac{v_i + v_f}{2} t$
$v_f^2 = v_i^2 + 2gh$	$v_f = v_i + gt$

$\sin(a \pm b)$	$\sin a \cos b \pm \cos a \sin b$
$\cos(a \pm b)$	$\cos a \cos b \mp \sin a \sin b$
$\sin^2 a$	$\frac{1}{2} (1 - \cos 2a)$

# Chapter 4

## Hws

### Local contents

4.1	HW 1 . . . . .	58
4.2	HW 2 . . . . .	87
4.3	HW 3 . . . . .	103
4.4	HW 3 different solution . . . . .	116
4.5	HW 4 . . . . .	126
4.6	HW 5 . . . . .	140
4.7	HW 6 . . . . .	160
4.8	HW 7 . . . . .	173
4.9	HW 8 . . . . .	192
4.10	HW 9 . . . . .	209
4.11	HW 10 . . . . .	231
4.12	HW 11 . . . . .	244

## 4.1 HW 1

## 4.1.1 Problem 1

## EMA 542

## Home Work to be Handed In

- 1) The cars of an amusement-park ride are attached to arms of length  $R$  which are hinged to a central rotating collar that drives the assembly about the vertical axis with a constant angular rate  $\omega$ . The cars rise and fall with the track according to the relation  $z = \frac{h}{2}(1 - \cos 2\theta)$ .

Determine for each car as it passes the position  $\theta = \frac{\pi}{4}$  rads:

- The expressions for the  $r$ -,  $\theta$ -, and  $\phi$ -components of velocity  $\vec{v}$ .
- The  $\theta$ -component of the acceleration  $\vec{a}$ .

Your answers should be in terms of  $h$ ,  $R$ , and  $\omega$ .

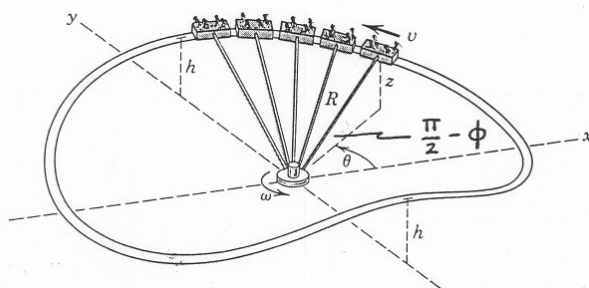

## 4.1.1.1 part (a)

In spherical coordinates the position vector and velocity vector of a car is given by

$$\begin{aligned}\vec{r} &= R\vec{e}_r + \theta\vec{e}_\theta + \phi\vec{e}_\phi \\ \vec{v} &= \dot{R}\vec{e}_r + R\dot{\phi}\vec{e}_\phi + R\dot{\theta}\sin\phi\vec{e}_\theta\end{aligned}$$

Since  $R$  is constant, then  $\dot{R} = 0$ . It is also given that  $\dot{\theta} = \omega$ . The above becomes

$$\vec{v} = R\dot{\phi}\vec{e}_\phi + R\omega\sin\phi\vec{e}_\theta \quad (1)$$

Given that

$$\begin{aligned} R \sin\left(\frac{\pi}{2} - \phi\right) &= \frac{h}{2}(1 - 2 \cos 2\theta) \\ \cos(\phi) &= \frac{h}{2R}(1 - 2 \cos 2\theta) \end{aligned} \quad (2)$$

And taking derivative w.r.t.

$$\begin{aligned} -\dot{\phi} \sin \phi &= \frac{2h}{R} \dot{\theta} \sin(2\theta) \\ \dot{\phi} &= \frac{-2h\dot{\theta} \sin(2\theta)}{R \sin \phi} \end{aligned} \quad (3)$$

Substituting the above in Eq. (1) gives

$$\vec{v} = \frac{-2h\dot{\theta} \sin(2\theta)}{\sin \phi} \vec{e}_\phi + R\omega \sin \phi \vec{e}_\theta$$

But from Eq. (2)

$$\phi = \arccos\left(\frac{h}{2R}(1 - 2 \cos 2\theta)\right)$$

hence  $\vec{v}$  becomes

$$\vec{v} = \frac{-2h\dot{\theta} \sin(2\theta)}{\sin\left(\arccos\left(\frac{h}{2R}(1 - 2 \cos 2\theta)\right)\right)} \vec{e}_\phi + R\omega \sin\left(\arccos\left(\frac{h}{2R}(1 - 2 \cos 2\theta)\right)\right) \vec{e}_\theta$$

When  $\theta = \frac{\pi}{4}$ ,  $\sin(2\theta) = 1$  and  $\cos 2\theta = 0$  the above becomes

$$\vec{v} = -\frac{2h\omega}{\sin\left(\arccos\left(\frac{h}{2R}\right)\right)} \vec{e}_\phi + R\omega \sin\left(\arccos\left(\frac{h}{2R}\right)\right) \vec{e}_\theta$$

But

$$\sin(\arccos(x)) = \sqrt{1 - x^2}$$

hence the above becomes

$$\vec{v} = -\frac{2h\omega}{\sqrt{1 - \frac{h^2}{4R^2}}} \vec{e}_\phi + R\omega \sqrt{1 - \frac{h^2}{4R^2}} \vec{e}_\theta$$

Therefore, the  $\vec{e}_\phi$  component is  $\frac{-2h\omega}{\sqrt{1 - \frac{h^2}{4R^2}}}$  and the  $\vec{e}_\theta$  is  $R\omega \sqrt{1 - \frac{h^2}{4R^2}}$  and the  $\vec{e}_r$  component is zero.

#### 4.1.1.2 Part (b)

The  $\theta$  component of the acceleration is given from eq. (1.30) in the class handout book as

$$R\ddot{\theta} \sin \phi + 2\dot{R}\dot{\theta} \sin \phi + 2R\dot{\phi}\dot{\theta} \cos \phi$$

Since  $\dot{R} = 0$  and  $\ddot{\theta} = 0$  (angular velocity is constant and the length of the swing arm is also constant) the above expression reduces to

$$2R\dot{\phi}\omega \cos \phi$$

From Eq. (3) in part(a), using  $\dot{\phi} = \frac{-2h\omega \sin(2\theta)}{R \sin \phi}$  and  $\phi = \arccos\left(\frac{h}{2R}(1 - 2 \cos 2\theta)\right)$ , the above simplifies to

$$2R \left( \frac{-2h\omega \sin(2\theta)}{R \sin\left(\arccos\left(\frac{h}{2R}(1 - 2 \cos 2\theta)\right)\right)} \right) \omega \cos\left(\arccos\left(\frac{h}{2R}(1 - 2 \cos 2\theta)\right)\right)$$

$$2R \left( \frac{-2h\omega \sin(2\theta)}{R \sin\left(\arccos\left(\frac{h}{2R}(1 - 2 \cos 2\theta)\right)\right)} \right) \omega \left(\frac{h}{2R}(1 - 2 \cos 2\theta)\right)$$

When  $\theta = \frac{\pi}{4}$ ,  $\sin(2\theta) = 1$  and  $\cos 2\theta = 0$ , the  $\theta$  component of the acceleration becomes

$$\left( \frac{-4h\omega}{\sin\left(\arccos\left(\frac{h}{2R}\right)\right)} \right) \frac{\omega h}{2R}$$

$$\left( \frac{-4h\omega}{\sqrt{1 - \left(\frac{h}{2R}\right)^2}} \right) \frac{\omega h}{2R}$$

$$\frac{-2}{R} \frac{h^2 \omega^2}{\sqrt{1 - \frac{h^2}{4R^2}}}$$



## 4.1.2 Problem A1

EMA 542  
Home Work to be Handed In

- 1A) The cone rolls without slipping such that at the instant shown,  $\omega_z = 4.0$  rad/sec. and  $\dot{\omega}_z = 3.0$  rad/sec<sup>2</sup>. Determine the total angular velocity and angular acceleration of the cone with respect to the fixed xyz coordinate system. Note that it is easiest to use velocity constraints to fulfill the no slip condition.

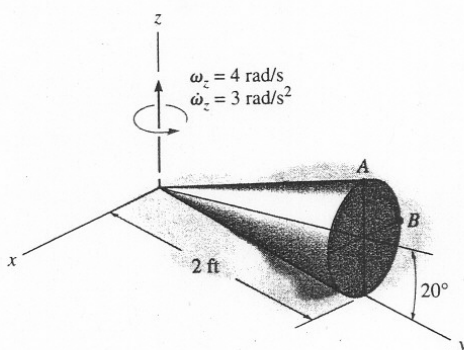

Let  $L$  be the side length of the cone (2 ft. in current diagram) and  $\vec{\omega}_c$  the angular velocity vector of the cone around its own axes, and  $r$  the cone base radius. Let  $\vec{\omega}_{total}$  be the angular velocity of cone w.r.t. the rigid frame  $XYZ$  (inertial frame), Hence vector additions gives

$$\vec{\omega}_{total} = \vec{\omega}_c + \vec{\omega}_z \quad (1)$$

No slipping implies

$$L\omega_z = r\omega_c$$

Or

$$\omega_c = \frac{L}{r}\omega_z$$

Hence Eq. (1) becomes

$$\vec{\omega}_{total} = \left(1 + \frac{L}{r}\right)\omega_z\vec{k}$$

Since  $\frac{r}{L} = \tan 20^\circ$ , then  $r = L \tan 20^\circ$  and the above simplifies to

$$\begin{aligned} \vec{\omega}_{total} &= \left(1 + \frac{1}{\tan 20^\circ}\right)(4)\vec{k} \\ &= 14.989\vec{k} \end{aligned}$$

The total angular acceleration of the cone is

$$\begin{aligned}\vec{\omega}_{total} &= \frac{d}{dt} \left( \left( 1 + \frac{L}{r} \right) \omega_z \vec{k} \right) \\ &= \left( 1 + \frac{1}{\tan 20^\circ} \right) \dot{\omega}_z \vec{k}\end{aligned}$$

But  $\dot{\omega}_z = 3 \text{ rad/sec}^2$  hence

$$\vec{\omega}_{total} = 11.241 \vec{k}$$

### 4.1.3 Problem 3

#### EMA 542

#### Home Work to be Handed In

- 2) The motion of a particle  $P$  along a fixed path is defined relative to the fixed  $xyz$  coordinate system by the parametric equations

$$\begin{aligned}R &= 1.5 \text{ m} \\ \phi &= 2t \text{ rad} \\ z &= t^2 \text{ m}\end{aligned}$$

where  $t$  is in seconds. At  $t = 0.25$  seconds, determine:

- The binormal unit vector  $\vec{e}_b$  in  $xyz$  coordinates.
- The speed  $v$  and acceleration  $\dot{v}$  along the path.
- The curvature  $K$ .
- The rate  $\dot{\theta}$  at which the normal and tangent vectors rotate within the osculating plane.
- Why is the binormal unit vector parallel to the vector  $\vec{v}_p \times \vec{a}_p$ ?

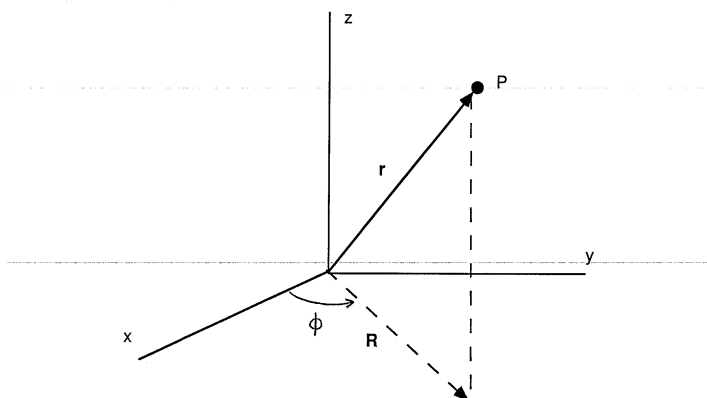

The position vector  $\vec{r}$  can be written as

$$\vec{r} = R \cos \phi \vec{i} + R \sin \phi \vec{j} + z \vec{k}$$

Taking derivatives w.r.t in the inertial frame, and since the unit vectors  $\vec{i}, \vec{j}, \vec{k}$  do not change in this frame, the following result is obtained

$$\vec{v} = \dot{R} \cos \phi \vec{i} - R \dot{\phi} \sin \phi \vec{i} + \dot{R} \sin \phi \vec{j} + R \dot{\phi} \cos \phi \vec{j} + \dot{z} \vec{k}$$

Since  $R$  do not change with time, the above simplifies to

$$\vec{v} = -R\dot{\phi} \sin \phi \vec{i} + R\dot{\phi} \cos \phi \vec{j} + \dot{z}\vec{k}$$

and the acceleration vector is

$$\begin{aligned} \vec{a} &= -\dot{R}\dot{\phi} \sin \phi \vec{i} - R\ddot{\phi} \sin \phi \vec{i} - R\dot{\phi}\dot{\phi} \cos \phi \vec{i} \\ &+ \dot{R}\dot{\phi} \cos \phi \vec{j} + R\ddot{\phi} \cos \phi \vec{j} - R\dot{\phi}\dot{\phi} \sin \phi \vec{j} \\ &+ \ddot{z}\vec{k} \end{aligned}$$

Since  $R$  do not change with time, the above simplifies to

$$\begin{aligned} \vec{a} &= -R\ddot{\phi} \sin \phi \vec{i} - R\dot{\phi}\dot{\phi} \cos \phi \vec{i} \\ &+ R\ddot{\phi} \cos \phi \vec{j} - R\dot{\phi}\dot{\phi} \sin \phi \vec{j} \\ &+ \ddot{z}\vec{k} \end{aligned}$$

Since  $\phi = 2t$ , then  $\dot{\phi} = 2$ ,  $\ddot{\phi} = 0$  and  $z = t^2$ ,  $\dot{z} = 2t$ ,  $\ddot{z} = 2$ . Substituting these values in the above two expressions for velocity and acceleration gives

$$\begin{aligned} \vec{v} &= -3 \sin(2t) \vec{i} + 3 \cos(2t) \vec{j} + 2t \vec{k} \\ \vec{a} &= -(1.5) 4 \cos(2t) \vec{i} - (1.5) 4 \sin(2t) \vec{j} + 2 \vec{k} \\ &= -6 \cos(2t) \vec{i} - 6 \sin(2t) \vec{j} + 2 \vec{k} \end{aligned}$$

At  $t = 0.25$  second,

$$\begin{aligned} \vec{v} &= -3 \sin(0.5) \vec{i} + 3 \cos(0.5) \vec{j} + 0.5 \vec{k} \\ &= -1.438 \vec{i} + 2.633 \vec{j} + 0.5 \vec{k} \quad [ft/s] \\ \vec{a} &= -6 \cos(0.5) \vec{i} - 6 \sin(0.5) \vec{j} + 2 \vec{k} \\ &= -5.266 \vec{i} - 2.877 \vec{j} + 2 \vec{k} \quad [ft/s^2] \end{aligned}$$

#### 4.1.3.1 part(a)

$$\begin{aligned} \vec{e}_t &= \frac{\vec{v}}{|\vec{v}|} \\ &= \frac{-1.438 \vec{i} + 2.633 \vec{j} + 0.5 \vec{k}}{\sqrt{1.438^2 + 2.633^2 + 0.5^2}} \\ &= \frac{-1.438 \vec{i} + 2.633 \vec{j} + 0.5 \vec{k}}{3.0414} \\ &= -0.473 \vec{i} + 0.866 \vec{j} + 0.164 \vec{k} \end{aligned}$$

and

$$\vec{a}_t = (\vec{a} \cdot \vec{e}_t) \vec{e}_t$$

But

$$\begin{aligned}(\vec{a} \cdot \vec{e}_t) &= (-5.266\vec{i} - 2.877\vec{j} + 2\vec{k}) \cdot (-0.473\vec{i} + 0.866\vec{j} + 0.164\vec{k}) \\ &= 0.329\end{aligned}$$

Hence

$$\begin{aligned}\vec{a}_t &= 0.329 (-0.473\vec{i} + 0.866\vec{j} + 0.164\vec{k}) \\ &= -0.155\vec{i} + 0.285\vec{j} + 0.054\vec{k} \quad [ft/s^2]\end{aligned}$$

Since  $\vec{a} = \vec{a}_t + \vec{a}_n$  then

$$\begin{aligned}\vec{a}_n &= \vec{a} - \vec{a}_t \\ &= (-5.266\vec{i} - 2.877\vec{j} + 2\vec{k}) - (-0.155\vec{i} + 0.284\vec{j} + 0.054\vec{k}) \\ &= -5.110\vec{i} - 3.161\vec{j} + 1.946\vec{k} \quad [ft/s^2]\end{aligned}$$

Hence

$$\begin{aligned}\vec{e}_n &= \frac{\vec{a}_n}{|\vec{a}_n|} = \frac{-5.110\vec{i} - 3.161\vec{j} + 1.946\vec{k}}{\sqrt{5.110^2 + 3.161^2 + 1.946^2}} \\ &= -0.809\vec{i} - 0.5\vec{j} + 0.308\vec{k}\end{aligned}$$

Hence

$$\begin{aligned}\vec{e}_b &= \vec{e}_t \times \vec{e}_n \\ &= (-0.473\vec{i} + 0.866\vec{j} + 0.164\vec{k}) \times (-0.809\vec{i} - 0.5\vec{j} + 0.308\vec{k}) \\ &= \begin{vmatrix} \vec{i} & \vec{j} & \vec{k} \\ -0.473 & 0.866 & 0.164 \\ -0.809 & -0.5 & 0.308 \end{vmatrix} \\ &= \vec{i}(0.866 \times 0.308 + 0.164 \times 0.5) - \vec{j}(-0.473 \times 0.308 + 0.164 \times 0.809) + \vec{k}(0.473 \times 0.5 + 0.866 \times 0.809) \\ &= 0.349\vec{i} - 0.0127\vec{j} + 0.937\vec{k}\end{aligned}$$

#### 4.1.3.2 Part (b)

The speed and acceleration was found above as

$$\begin{aligned}\vec{v} &= -1.438\vec{i} + 2.633\vec{j} + 0.5\vec{k} \quad [ft/s] \\ \vec{a} &= -5.266\vec{i} - 2.877\vec{j} + 2\vec{k} \quad [ft/s^2]\end{aligned}$$

**4.1.3.3 Part(c)**

since

$$\begin{aligned} |\vec{a}_n| &= \frac{\dot{s}^2}{\rho} \\ &= \frac{|\vec{v}|^2}{\rho} \end{aligned}$$

Hence

$$\rho = \frac{|\vec{v}|^2}{|\vec{a}_n|} = \frac{|-1.438\vec{i} + 2.633\vec{j} + 0.5\vec{k}|^2}{|-5.110\vec{i} - 3.161\vec{j} + 1.946\vec{k}|} = \frac{1.438^2 + 2.633^2 + 0.5^2}{\sqrt{5.110^2 + 3.161^2 + 1.946^2}} = 1.465 \quad [ft]$$

But

$$k = \frac{1}{\rho} = \frac{1}{1.465} = 0.683$$

**4.1.3.4 Part (d)**

$$\begin{aligned} \dot{\theta} &= \frac{\dot{s}}{\rho} \\ &= \frac{|\vec{v}|}{\rho} \end{aligned}$$

At  $t = 0.25$  sec.

$$\begin{aligned} \dot{\theta} &= \frac{|-1.438\vec{i} + 2.633\vec{j} + 0.5\vec{k}|}{1.465} \\ &= \frac{\sqrt{1.438^2 + 2.633^2 + 0.5^2}}{1.465} \\ &= 2.076 \quad [rad/sec] \end{aligned}$$

**4.1.3.5 Part(c)**

$$\begin{aligned} \vec{v} \times \vec{a} &= \vec{v} \times (\vec{a}_t + \vec{a}_n) \\ &= (\vec{v} \times \vec{a}_t) + (\vec{v} \times \vec{a}_n) \\ &= (|\vec{v}| \vec{e}_t \times |\vec{a}_t| \vec{e}_t) + (|\vec{v}| \vec{e}_t \times |\vec{a}_n| \vec{e}_n) \\ &= |\vec{v}| |\vec{a}_t| (\vec{e}_t \times \vec{e}_t) + |\vec{v}| |\vec{a}_n| (\vec{e}_t \times \vec{e}_n) \end{aligned}$$

But  $\vec{e}_t \times \vec{e}_t = 0$  and  $\vec{e}_t \times \vec{e}_n$  using the right-hand rule is  $\vec{e}_b$  hence

$$\vec{v} \times \vec{a} = |\vec{v}| |\vec{a}_n| \vec{e}_b$$

This is a vector parallel to  $\vec{e}_b$  of magnitude  $|\vec{v}| |\vec{a}_n|$

## 4.1.4 Problem 4

**Homework #1**  
EMA 542, Fall 2007

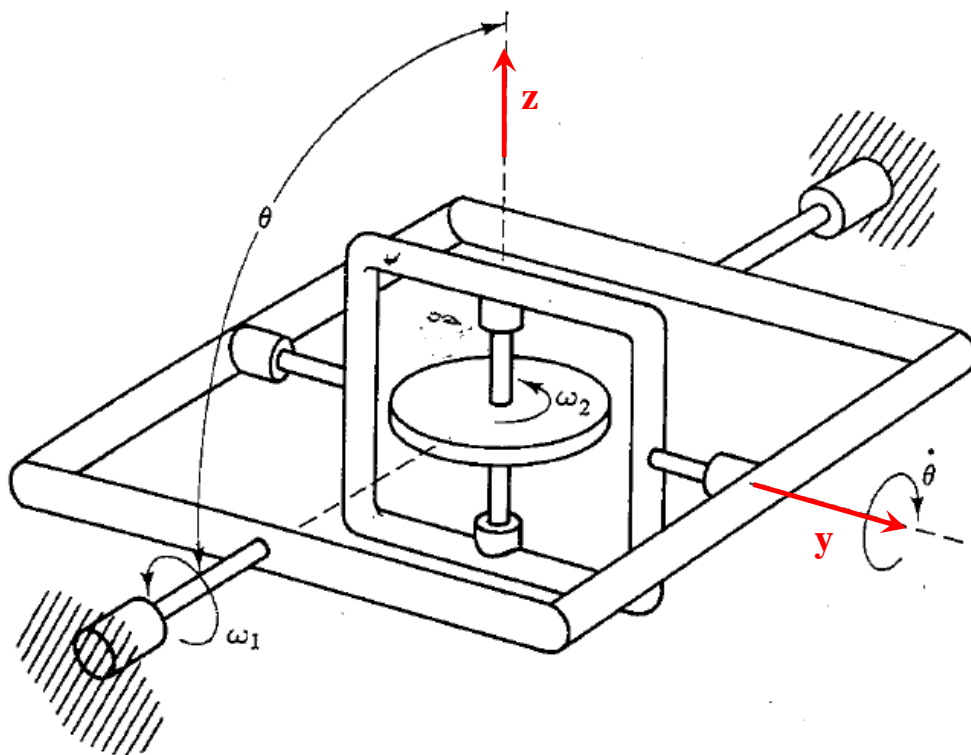
**Problem #1**

- 3.15 The flywheel of the gyroscope rotates about its own axis at  $\omega_2 = 6,000$  rev/min. At the instant when  $\theta = 120^\circ$ , the inner gimbal support is rotating relative to the outer gimbal at  $\dot{\theta} = 6$  rad/s and  $\ddot{\theta} = -90$  rad/s<sup>2</sup>. The corresponding rotation of the outer gimbal about the horizontal axis is  $\omega_1 = 10$  rad/s,  $\dot{\omega}_1 = 100$  rad/s<sup>2</sup>. Determine the angular velocity and angular acceleration of the flywheel at this instant.

Please give your solution in terms of components in the reference frame illustrated above that is attached to the inner gimbal. The  $y$  axis is oriented along the axis of the pin joint connecting the inner gimbal to the outer gimbal and the  $z$  axis is aligned with the axis of rotation of the flywheel.

There is local frame of reference attached to the inner gimbal as shown in the following diagram

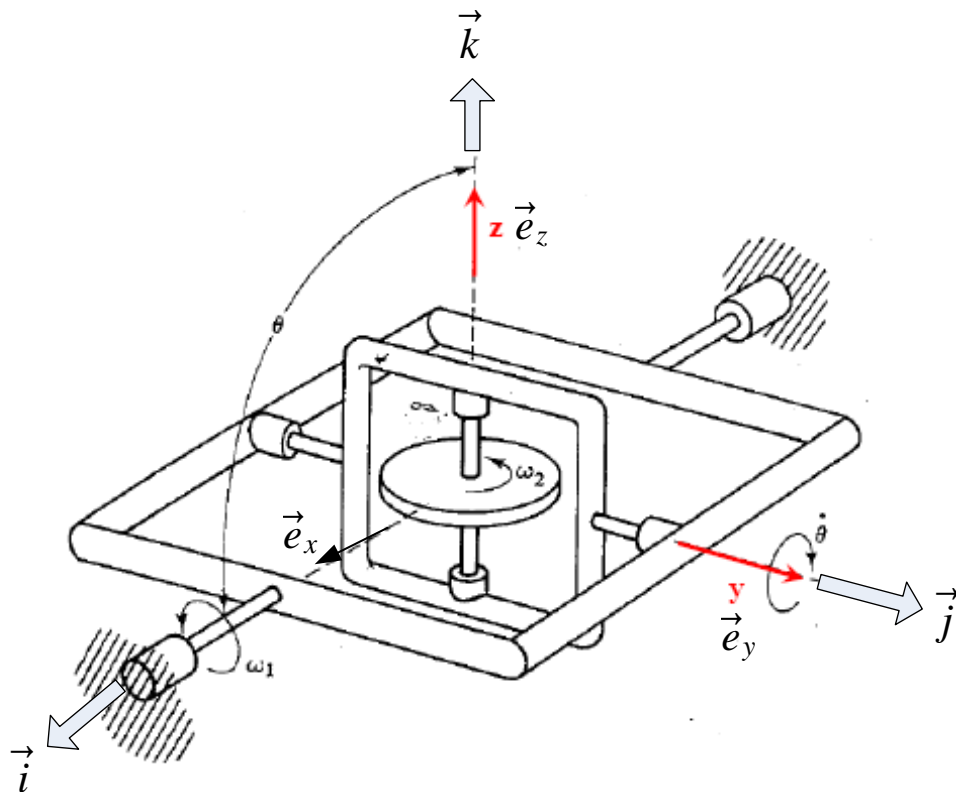

$\vec{e}_x, \vec{e}_y, \vec{e}_z$  are unit vectors that are local to the inner gimbal.  
 $\vec{i}, \vec{j}, \vec{k}$  are the inertial unit vectors.

Given these, the angular velocity vector of the fly wheel can be written as (in terms of local coordinates system)

$$\vec{\omega}_{wheel} = \omega_1 \vec{e}_x - \dot{\theta} \vec{e}_y + \omega_2 \vec{e}_z \quad (1)$$

Hence, taking derivatives

$$\dot{\vec{\omega}}_{wheel} = \dot{\omega}_1 \vec{e}_x + \omega_1 \dot{\vec{e}}_x - \ddot{\theta} \vec{e}_y - \dot{\theta} \dot{\vec{e}}_y + \dot{\omega}_2 \vec{e}_z + \omega_2 \dot{\vec{e}}_z$$

But  $\dot{\omega}_2 = 0$  then

$$\dot{\vec{\omega}}_{wheel} = \dot{\omega}_1 \vec{e}_x + \omega_1 \dot{\vec{e}}_x - \ddot{\theta} \vec{e}_y - \dot{\theta} \dot{\vec{e}}_y + \omega_2 \dot{\vec{e}}_z \quad (2)$$

But

$$\begin{aligned}
 \dot{\vec{e}}_x &= \omega_{e_x} \times \vec{e}_x \\
 &= (-\dot{\theta}\vec{j} + \omega_1\vec{i}) \times \vec{e}_x \\
 &= (-\dot{\theta}\vec{j} \times \vec{e}_x) + (\omega_1\vec{i} \times \vec{e}_x) \\
 &= \dot{\theta}\vec{e}_z - \sin\theta\vec{e}_y
 \end{aligned}$$

and

$$\begin{aligned}
 \dot{\vec{e}}_y &= \omega_{e_y} \times \vec{e}_y \\
 &= \omega_1\vec{i} \times \vec{e}_y \\
 &= \omega_1\vec{e}_z
 \end{aligned}$$

and

$$\begin{aligned}
 \dot{\vec{e}}_z &= \omega_{e_z} \times \vec{e}_z \\
 &= (-\dot{\theta}\vec{j} + \omega_1\vec{i}) \times \vec{e}_y \\
 &= (-\dot{\theta}\vec{j} \times \vec{e}_y) + (\omega_1\vec{i} \times \vec{e}_y) \\
 &= -\dot{\theta}\vec{e}_x \sin\omega_1 t + \omega_1\vec{e}_z
 \end{aligned}$$

Assuming  $t = 0$  is when the instance taken, the above becomes (we are not given time)

$$\dot{\vec{e}}_z = \omega_1\vec{e}_z$$

Hence Eq. (2) becomes

$$\begin{aligned}
 \dot{\vec{\omega}}_{wheel} &= \dot{\omega}_1\vec{e}_x + \omega_1\dot{\vec{e}}_x - \ddot{\theta}\vec{e}_y - \dot{\theta}\dot{\vec{e}}_y + \omega_2\dot{\vec{e}}_z \\
 &= \dot{\omega}_1\vec{e}_x + \omega_1(\dot{\theta}\vec{e}_z - \sin\theta\vec{e}_y) - \ddot{\theta}\vec{e}_y - \dot{\theta}(\omega_1\vec{e}_z) + \omega_2(\omega_1\vec{e}_z) \\
 &= \dot{\omega}_1\vec{e}_x - \vec{e}_y(\ddot{\theta} + \omega_1\sin\theta) + \omega_2\omega_1\vec{e}_z
 \end{aligned} \tag{3}$$

Since  $\omega_2 = 6000 \text{ rev/min}$  or  $\frac{6000(2\pi)}{60} = 200\pi \text{ rad/sec}$ ,  $\omega_1 = 10 \text{ rad/sec}$ ,  $\dot{\omega}_1 = 100 \text{ rad/sec}^2$ ,  $\dot{\theta} = 6 \text{ rad/sec}$ ,  $\ddot{\theta} = -90 \text{ rad/sec}^2$ ,  $\theta = 120^\circ$ , then Eq. (1) becomes

$$\begin{aligned}
 \vec{\omega}_{wheel} &= 10\vec{e}_x - 6\vec{e}_y + 200\pi\vec{e}_z \\
 |\vec{\omega}_{wheel}| &= \sqrt{10^2 + 6^2 + (200\pi)^2} \\
 &= 628.43 \text{ rad/sec}
 \end{aligned}$$



and Eq. (3) becomes

$$\begin{aligned}\vec{\dot{\omega}}_{wheel} &= 100\vec{e}_x - \vec{e}_y(-90 + 10 \sin 120^\circ) + \vec{e}_z(2000\pi) \\ &= 100\vec{e}_x - \vec{e}_y\left(-90 + 10\frac{\sqrt{3}}{2}\right) + \vec{e}_z(2000\pi) \\ &= 100\vec{e}_x + 81.34\vec{e}_y + 6283.2\vec{e}_z\end{aligned}$$

Hence

$$\begin{aligned}|\vec{\dot{\omega}}_{wheel}| &= \sqrt{100^2 + 81.34^2 + 6283.2^2} \\ &= 6284.5 \text{ rad/sec}^2\end{aligned}$$

## 4.1.5 key solution

## EMA 542

## Home Work to be Handed In

- 1) The cars of an amusement-park ride are attached to arms of length  $R$  which are hinged to a central rotating collar that drives the assembly about the vertical axis with a constant angular rate  $\omega$ . The cars rise and fall with the track according to the relation  $z = \frac{h}{2}(1 - \cos 2\theta)$ .

Determine for each car as it passes the position  $\theta = \frac{\pi}{4}$  rads:

- The expressions for the  $r$ -,  $\theta$ -, and  $\phi$ -components of velocity  $\vec{v}$ .
- The  $\theta$ -component of the acceleration  $\vec{a}$ .

Your answers should be in terms of  $h$ ,  $R$ , and  $\omega$ .

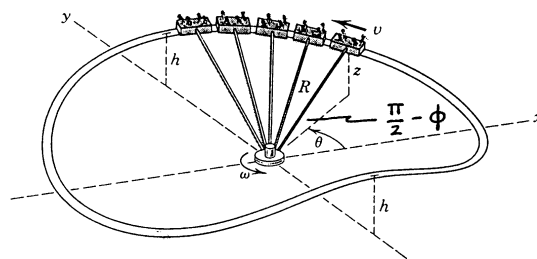

NOTICE: This MATERIAL MAY  
BE PROTECTED BY  
Copyright Law (Title 17 US Code)

9/15/93

EMA 542 - SPHERICAL COORD. EX

2/169

$$\vec{r} = R \vec{e}_r$$

$$\begin{aligned} \therefore \dot{\vec{r}} &= \dot{R} \vec{e}_r + R \dot{\vec{e}}_r = \dot{R} \vec{e} + \vec{\omega}_r \times R \vec{e}_r \\ &= \vec{\omega}_r \times R \vec{e}_r \quad \dot{R} = 0 \end{aligned}$$

$$\vec{\omega}_r = \dot{\theta} \vec{e}_\theta + \dot{\phi} \vec{e}_\phi \quad \dot{\theta} = \omega = \text{CONST.}$$

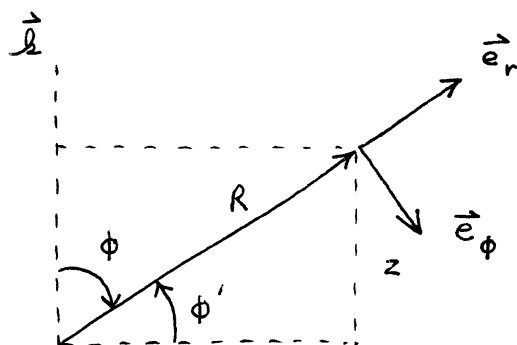

$$z = R \cos \phi = \frac{h}{2} (1 - \cos 2\theta)$$

TAKING TIME  
DERIVATIVES OF  
BOTH SIDES

$$\Rightarrow -R \dot{\phi} \sin \phi = h \sin 2\theta \dot{\theta}$$

$$\Rightarrow \dot{\phi} = -\frac{h}{R} \dot{\theta} \frac{\sin 2\theta}{\sin \phi} \quad @ \theta = \frac{\pi}{4} \quad \cos \phi = \frac{h}{2R}$$

$$\therefore \sin \phi = \sqrt{1 - \left(\frac{h}{2R}\right)^2} \Rightarrow \dot{\phi} = -\frac{h}{R} \frac{1}{\sqrt{1 - \left(\frac{h}{2R}\right)^2}} \dot{\theta}$$

- 2 -

$$\therefore \vec{\omega}_r = \dot{\theta} \cos\phi \vec{e}_r - \dot{\theta} \sin\phi \vec{e}_\phi + \dot{\phi} \vec{e}_\theta$$

$$\begin{aligned} \therefore \vec{\omega}_r \times R\vec{e}_r &= [\dot{\theta} \cos\phi \vec{e}_r - \dot{\theta} \sin\phi \vec{e}_\phi + \dot{\phi} \vec{e}_\theta] \times R\vec{e}_r \\ &= R\dot{\theta} \sin\phi \vec{e}_\theta + R\dot{\phi} \vec{e}_\phi \end{aligned}$$

$$\therefore \vec{v} = R\omega \sqrt{1 - \left(\frac{h}{2R}\right)^2} \vec{e}_\theta - \frac{h\omega}{\sqrt{1 - \left(\frac{h}{2R}\right)^2}} \vec{e}_\phi$$

$$\therefore V_\theta = R\omega \sqrt{1 - \left(\frac{h}{2R}\right)^2}$$

$$V_\phi = \frac{-h\omega}{\sqrt{1 - \left(\frac{h}{2R}\right)^2}} \quad \text{or} \quad V_\phi = \frac{h\omega}{\sqrt{1 - \left(\frac{h}{2R}\right)^2}}$$

$$V_r = 0$$

USING  $\phi$  IN FIGURE

- 3 -

ACCELERATION

$$\dot{\vec{v}} = \dot{\vec{v}}_e + \dot{\vec{v}}_\phi$$

$$\vec{v}_e = R\dot{\theta} \sin\phi \vec{e}_\theta = v_e \vec{e}_\theta$$

$$\vec{v}_\phi = R\dot{\phi} \vec{e}_\phi = v_\phi \vec{e}_\phi$$

$$\therefore \dot{\vec{v}}_e = \dot{v}_e \vec{e}_e + \vec{\omega}_e \times \vec{v}_e$$

$$\text{NOTE } \vec{\omega}_e = \vec{\omega}_r = \vec{\omega}_\phi$$

$$\begin{aligned} \therefore \dot{\vec{v}}_e &= R\dot{\theta}\dot{\phi} \cos\phi \vec{e}_\theta + R\dot{\theta} \sin\phi [\dot{\theta} \cos\phi \vec{e}_r \\ &\quad - \dot{\theta} \sin\phi \vec{e}_\phi + \dot{\phi} \vec{e}_\theta] \times \vec{e}_\theta \end{aligned}$$

$$\Rightarrow \dot{\vec{v}}_e = R\dot{\theta}\dot{\phi} \cos\phi \vec{e}_\theta + R\dot{\theta} \sin\phi [-\dot{\theta} \cos\phi \vec{e}_\phi \\ - \dot{\theta} \sin\phi \vec{e}_r]$$

$$\begin{aligned} \Rightarrow \dot{\vec{v}}_e &= -R\dot{\theta}^2 \sin^2\phi \vec{e}_r + \dot{\phi} \cos\phi \vec{e}_\theta R\dot{\theta} \\ &\quad - R\dot{\theta}^2 \sin\phi \cos\phi \vec{e}_\phi \end{aligned}$$

- 4 -

$$\begin{aligned}
 \dot{\vec{V}}_{\phi} &= \dot{V}_{\phi} \vec{e}_{\phi} + \vec{\omega}_{\phi} \times \vec{V}_{\phi} \\
 &= R \ddot{\phi} \vec{e}_{\phi} + R \dot{\phi} \left[ \dot{\theta} \cos \phi \vec{e}_r - \dot{\theta} \sin \phi \vec{e}_{\phi} \right. \\
 &\quad \left. + \dot{\phi} \vec{e}_{\theta} \right] \times \vec{e}_{\phi} \\
 &= R \ddot{\phi} \vec{e}_{\phi} + R \dot{\phi} \left[ \dot{\theta} \cos \phi \vec{e}_{\theta} - \dot{\phi} \vec{e}_r \right] \\
 \therefore \dot{\vec{V}}_{\phi} &= -R \dot{\phi}^2 \vec{e}_r + R \ddot{\phi} \vec{e}_{\phi} + R \dot{\phi} \dot{\theta} \cos \phi \vec{e}_{\theta}
 \end{aligned}$$

FROM DIFFERENTIATE:

$$\ddot{\phi} = -\frac{h}{R} \dot{\theta} \left[ 2 \dot{\theta} \frac{\cos 2\theta}{\sin \phi} - \dot{\phi} \frac{\sin 2\theta \cos \phi}{\sin^2 \phi} \right]$$

$$@ \theta = \frac{\pi}{4} \quad \cos 2\theta = 0 \quad \sin 2\theta = 1$$

$$\cos \phi = \frac{h}{2R} \quad \sin \phi = \sqrt{1 - \left(\frac{h}{2R}\right)^2}$$

$$\therefore \ddot{\phi} = +\frac{h}{R} \omega \left(-\frac{h}{R} \omega\right) \frac{1}{\sqrt{1 - \left(\frac{h}{2R}\right)^2}} \frac{\frac{h}{2R}}{\left(1 - \left[\frac{h}{2R}\right]^2\right)}$$

$$\underline{\ddot{\phi}} = -\frac{1}{2} \left(\frac{h}{R}\right)^3 \omega^2 \left[1 - \left(\frac{h}{2R}\right)^2\right]^{-3/2}$$

- 5 -

$$\therefore a_r = -R\omega^2 \left[ 1 - \left(\frac{h}{2R}\right)^2 \right] - R \left(\frac{h}{R}\right)^2 \omega^2 \frac{1}{\left[ 1 - \left(\frac{h}{2R}\right)^2 \right]}$$

$$\underline{a_r} = -R\omega^2 \left\{ 1 - \left(\frac{h}{2R}\right)^2 - \frac{\left(\frac{h}{R}\right)^2}{\left[ 1 - \left(\frac{h}{2R}\right)^2 \right]} \right\}$$

$$a_\theta = R\dot{\theta} \dot{\phi} \cos\phi + R\dot{\phi} \ddot{\theta} \cos\phi = 2R\dot{\theta} \dot{\phi} \cos\phi$$

$$\therefore a_\theta = -2R\omega \left(\frac{h}{2R}\right) \frac{h}{R} \omega \frac{1}{\sqrt{1 - \left(\frac{h}{2R}\right)^2}}$$

$$\underline{a_\theta} = -\frac{h^2 \omega^2}{R \sqrt{1 - \left(\frac{h}{2R}\right)^2}}$$

$$a_\phi = -R\dot{\theta}^2 \sin\phi \cos\phi + R\ddot{\phi}$$

$$= -R\omega^2 \frac{h}{2R} \sqrt{1 - \left(\frac{h}{2R}\right)^2} - \frac{R}{2} \left(\frac{h}{R}\right)^3 \omega^2 \left[ 1 - \left(\frac{h}{2R}\right)^2 \right]^{-3/2}$$

$$a_\phi = \dots$$

## EMA 542

## Home Work to be Handed In

- 1A) The cone rolls without slipping such that at the instant shown,  $\omega_z = 4.0$  rad/sec. and  $\dot{\omega}_z = 3.0$  rad/sec<sup>2</sup>. Determine the total angular velocity and angular acceleration of the cone with respect to the fixed xyz coordinate system. Note that it is easiest to use velocity constraints to fulfill the no slip condition.

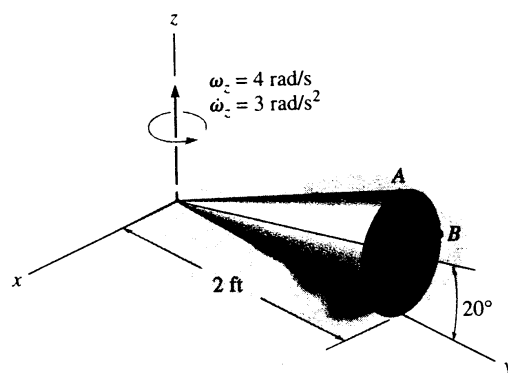



9/8/97

SOLUTION TO 542 HWK 1a

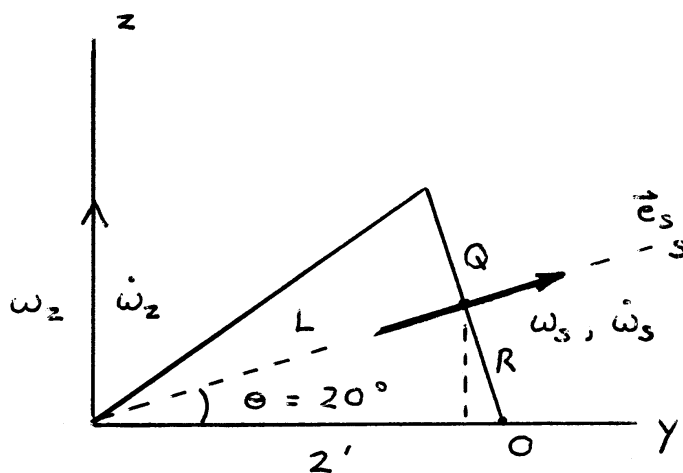

No slip

$$\omega_2 = 4 \text{ rad/s}$$

$$\dot{\omega}_2 = 3 \text{ rad/s}^2$$

$$V_o = 0$$

$\omega_s$  = SPIN ANGULAR VELOCITY DUE TO NO SLIP CONDITION

$\vec{\Omega}$  = TOTAL ANGULAR VELOCITY OF CONE

$$\vec{\Omega} = \vec{\omega}_2 + \vec{\omega}_s \tag{A}$$

$$\vec{v}_Q = -\omega_2 L \cos 20 \vec{i} \quad L = 2 \cos 20$$

$$\Rightarrow \vec{v}_Q = -\omega_2 L \cos 20 \vec{i} \tag{1}$$

LOOK DOWN  
S AXIS

ASSUME  $\Omega_s$   
IN POSITIVE  
DIRECTION

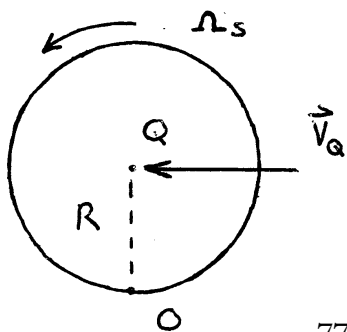

$$\vec{v}_Q = R \Omega_s \vec{i}$$

$$R = L \tan 20$$

$$\vec{v}_Q = L \Omega_s \tan 20 \vec{i} \tag{2}$$

- 2 -

NOTE THAT  $\Omega_S$  IS THE TOTAL ANGULAR VELOCITY OF THE CONE ALONG THE S AXIS.

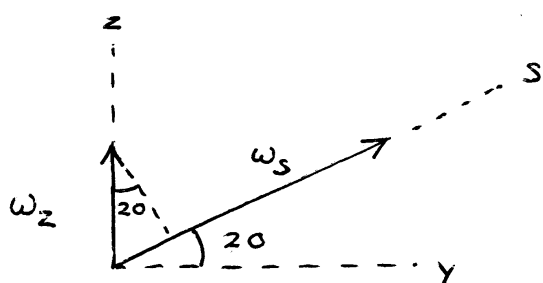

ALSO ASSUME  $\omega_S$  IN POSITIVE DIRECTION

$$\therefore \textcircled{A} \Rightarrow \Omega_S = \omega_2 \sin 20 + \omega_S$$

OR

EQUATING ① & ②:

$$\Rightarrow -\omega_2 L \cos 20 = L \Omega_S \tan 20$$

$$\Rightarrow -\omega_2 \cos 20 = (\omega_2 \sin 20 + \omega_S) \tan 20$$

$$\Rightarrow -\omega_2 \cos^2 20 = \omega_2 \sin^2 20 + \omega_S \sin 20$$

$$\text{OR} \quad -\frac{\omega_2}{\sin 20} = \omega_S \quad \text{ASSUMED IN } \textcircled{3} \\ \text{WRONG DIRECTION}$$

$$\therefore \vec{\omega}_S = -\frac{\omega_2}{\sin 20} \vec{e}_S = -\frac{\omega_2}{\sin 20} [\cos 20 \vec{j} + \sin 20 \vec{k}]$$

$$\text{OR} \quad \vec{\omega}_S = -\omega_2 \cot 20 \vec{j} - \omega_2 \vec{k}$$

- 3 -

$$\therefore \vec{\omega} = \vec{\omega}_2 + \vec{\omega}_3 = -\omega_2 \cot 20^\circ \vec{j}$$

$$\text{OR } \vec{\omega} = -10.99 \text{ r/s } \vec{j}$$

Now compute  $\dot{\vec{\omega}}$ :

$$\dot{\vec{\omega}} = \dot{\vec{\omega}}_2 + \dot{\vec{\omega}}_3$$

$$\dot{\vec{\omega}}_2 = \dot{\omega}_2 \vec{k} + \vec{\omega}_{\omega_2} \times \vec{\omega}_2 \quad \vec{\omega}_{\omega_2} = 0$$

$$\therefore \dot{\vec{\omega}}_2 = 3\vec{k} \quad (4)$$

$$\dot{\vec{\omega}}_3 = \dot{\omega}_3 \vec{e}_3 + \vec{\omega}_{\omega_3} \times \vec{\omega}_3 \quad \vec{\omega}_{\omega_3} = \omega_2 \vec{k}$$

$$= \frac{-\dot{\omega}_2}{\sin 20} \vec{e}_3 + \omega_2 \vec{k} \times \omega_2 [-\cot 20^\circ \vec{j} - \omega_2 \vec{k}]$$

$$= -\dot{\omega}_2 \cot 20^\circ \vec{j} - \dot{\omega}_2 \vec{k} + \omega_2^2 \cot 20^\circ \vec{i}$$

$$\dot{\vec{\omega}}_3 = 16 \cot 20^\circ \vec{i} - 3 \cot 20^\circ \vec{j} - 3\vec{k} \quad (5)$$

$$(4) + (5) \Rightarrow \dot{\vec{\omega}} = 16 \cot 20^\circ \vec{i} - 3 \cot 20^\circ \vec{j}$$

$$= 43.96 \vec{i} - 8.24 \vec{j}$$

**EMA 542**  
**Home Work to be Handed In**

- 2) The motion of a particle  $P$  along a fixed path is defined relative to the fixed  $xyz$  coordinate system by the parametric equations

$$R = 1.5 \text{ m}$$

$$\phi = 2t \text{ rad}$$

$$z = t^2 \text{ m}$$

where  $t$  is in seconds. At  $t = 0.25$  seconds, determine:

- The binormal unit vector  $\bar{e}_b$  in  $xyz$  coordinates.
- The speed  $v$  and acceleration  $\dot{v}$  along the path.
- The curvature  $K$ .
- The rate  $\dot{\theta}$  at which the normal and tangent vectors rotate within the osculating plane.
- Why is the binormal unit vector parallel to the vector  $\bar{v}_p \times \bar{a}_p$ ?

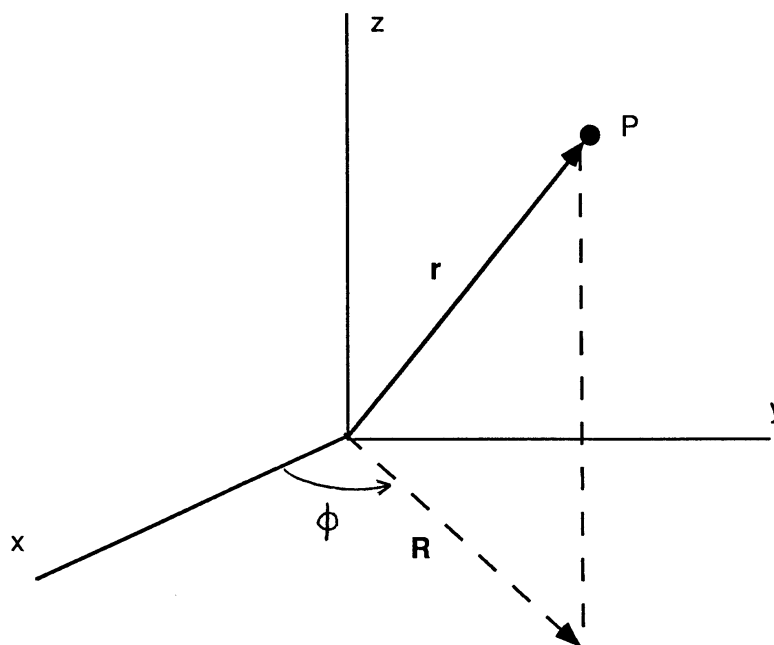

EMA 542 - HOMEWORK TO BE HANDLED IN - # 2

$$R = 1.5 \quad \phi = 2t \quad z = t^2$$

$$\text{@ } t = 0.25 \text{ sec.} \quad R = 1.5 \quad \phi = 0.5 \quad z = .0625$$

IN CYLINDRICAL COORDINATES:

$$\vec{v} = \dot{R} \vec{e}_R + R \dot{\phi} \vec{e}_\phi + \dot{z} \vec{k} \quad (1)$$

$$\dot{R} = 0 \quad \dot{\phi} = 2 \quad \dot{z} = 2t$$

$$\Rightarrow \vec{v} = R \dot{\phi} \vec{e}_\phi + \dot{z} \vec{k} = 3 \vec{e}_\phi + 2t \vec{k} \quad (2)$$

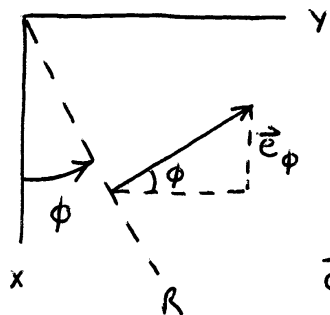

$$\vec{e}_\phi = -\sin\phi \vec{i} + \cos\phi \vec{j}$$

$$\therefore \vec{v} = -3\sin\phi \vec{i} + 3\cos\phi \vec{j} + 2t \vec{k} \quad (3)$$

$$\vec{e}_t = \frac{\vec{v}}{|\vec{v}|}$$

$$v = [3^2 \sin^2\phi + 3^2 \cos^2\phi + 4t^2]^{1/2}$$

$$= [9 + 4t^2]^{1/2} \quad (4)$$

$$\text{@ } t = 1/4 \quad v = 3.041 \text{ m/s}$$

- 2 -

$$\therefore \vec{e}_t = \frac{[-3\sin\phi \bar{x} + 3\cos\phi \bar{y} + 2t \bar{z}]}{[9 + 4t^2]^{1/2}} \quad (5)$$

$$\text{@ } t = \frac{1}{4} \quad \vec{e}_t = -.473 \bar{x} + .866 \bar{y} + .164 \bar{z} \quad (6)$$

$$\text{Eq (3)} \Rightarrow \dot{\vec{v}} = -3\dot{\phi} \cos\phi \bar{x} - 3\dot{\phi} \sin\phi \bar{y} + 2 \bar{z} = \vec{a} \quad (7)$$

$$\text{@ } t = \frac{1}{4} \quad \vec{a} = -5.265 \bar{x} - 2.877 \bar{y} + 2 \bar{z} \quad (8)$$

$$|\vec{a}_t| = \vec{a} \cdot \vec{e}_t = 2.490 - 2.491 + .328$$

$$\Rightarrow a_t = 0.328 \quad \text{m/s}^2$$

$$\therefore \vec{a}_t = .328 \vec{e}_t = -.155 \bar{x} + .284 \bar{y} + .054 \bar{z} \quad (9)$$

$$\Rightarrow \vec{a}_N = \vec{a} - \vec{a}_t = (-5.265 + .155) \bar{x} + (-2.877 - .284) \bar{y} \\ + (2 - .054) \bar{z}$$

$$\vec{a}_N = -5.110 \bar{x} - 3.161 \bar{y} + 1.946 \bar{z} \quad (10)$$

$$a_N = [(5.110)^2 + (3.161)^2 + (1.946)^2]^{1/2}$$

$$a_N = 6.316 \text{ m/s}^2$$

- 3 -

$$a_N = \frac{v^2}{\rho} \Rightarrow 6.316 = \frac{(3.041)^2}{\rho}$$

$$\Rightarrow \rho = 1.464 \text{ m} \quad K = \frac{1}{\rho} = .683 \text{ m}^{-1}$$

$$\text{ALSO: } v = \rho \dot{\theta} \Rightarrow \dot{\theta} = \frac{3.041}{1.464}$$

$$\therefore \dot{\theta} = 2.077 \text{ rad/s}$$

$$\text{ALSO: } \vec{e}_b = \vec{e}_t \times \vec{e}_N$$

$$\vec{e}_N = \frac{\vec{a}_N}{a_N} = -.809\vec{i} - .500\vec{j} + .308\vec{k} \quad (11)$$

$$\therefore \vec{e}_t \times \vec{e}_N = [-.473\vec{i} + .866\vec{j} + .164\vec{k}]$$

$$\times [-.809\vec{i} - .500\vec{j} + .308\vec{k}] = \vec{e}_b$$

$$\therefore \vec{e}_b = .237\vec{k} + .146\vec{j} + .701\vec{k} + .267\vec{i} \\ - .133\vec{j} + .082\vec{i}$$

- 4 -

COLLECTING SOLUTIONS:

$$(a) \quad \vec{e}_b = .349 \vec{i} + .013 \vec{j} + .938 \vec{k}$$

$$(b) \quad v = 3.041 \text{ m/s} \quad \dot{v} = a_e = 0.328 \text{ m/s}^2$$

$$(c) \quad K = 0.683 \text{ m}^{-1}$$

$$(d) \quad \dot{\theta} = 2.077 \text{ m/s}$$

(e) BOTH  $\vec{v}_p$  AND  $\vec{a}_p$ , THE VELOCITY AND ACCELERATION OF  $P$ , RESPECTIVELY, ALWAYS LIE IN OSCULATING PLANE. THEIR CROSS PRODUCT IS THEREFORE NORMAL TO THE OSCULATING PLANE AND PARALLEL TO  $\vec{e}_b$



**Homework #1**  
EMA 542, Fall 2007

**Problem #1**

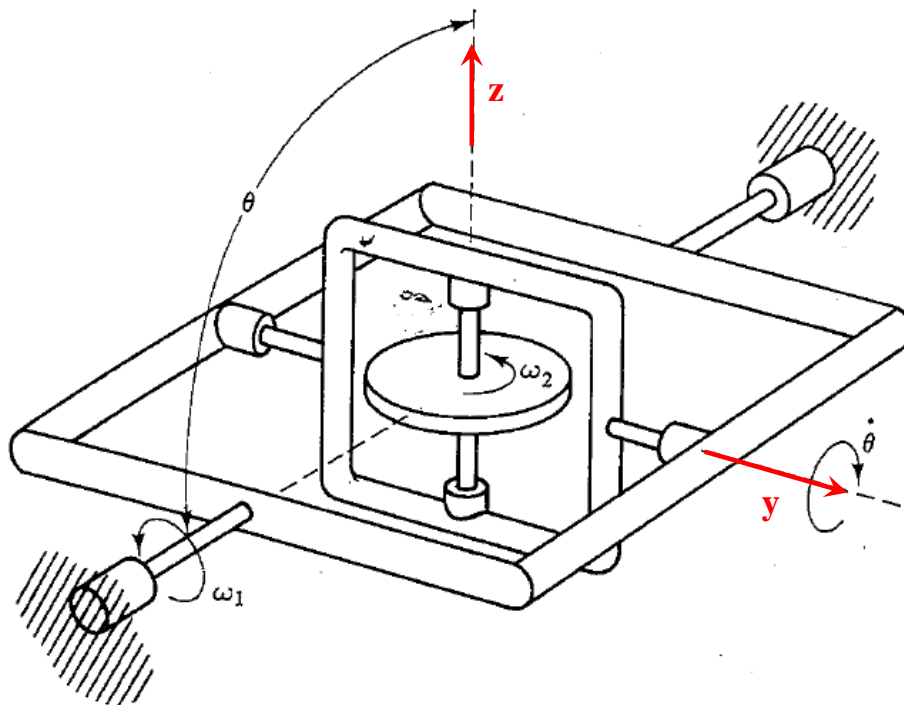

- 3.15 The flywheel of the gyroscope rotates about its own axis at  $\omega_2 = 6,000$  rev/min. At the instant when  $\theta = 120^\circ$ , the inner gimbal support is rotating relative to the outer gimbal at  $\dot{\theta} = 6$  rad/s and  $\ddot{\theta} = -90$  rad/s<sup>2</sup>. The corresponding rotation of the outer gimbal about the horizontal axis is  $\omega_1 = 10$  rad/s,  $\dot{\omega}_1 = 100$  rad/s<sup>2</sup>. Determine the angular velocity and angular acceleration of the flywheel at this instant.

Please give your solution in terms of components in the reference frame illustrated above that is attached to the inner gimbal. The y axis is oriented along the axis of the pin joint connecting the inner gimbal to the outer gimbal and the z axis is aligned with the axis of rotation of the flywheel.

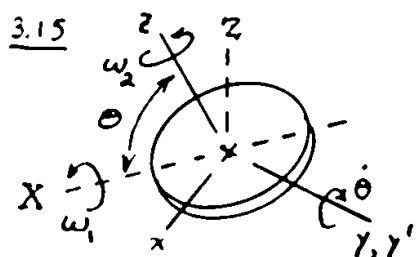

Given:  $\omega_z = 6000 \left( \frac{2\pi}{60} \right) \text{ rad/s}$ ,  $\dot{\omega}_z = 0$ ,  
 when  $\theta = 120^\circ$ :  $\dot{\theta} = 6 \text{ rad/s}$ ,  $\ddot{\theta} =$   
 $-90 \text{ rad/s}^2$ ,  $\omega_1 = 10 \text{ rad/s}$ ,  $\dot{\omega}_1 = 100 \text{ rad/s}^2$ .  
 Find  $\bar{\omega}$  &  $\bar{\alpha}$  at this instant.

Solution: Fix  $xyz$  to the flywheel,

and fix  $x'y'z'$  to the outer gimbel. Select instantaneous orientations such that  $\bar{j}' = \bar{j}$  &  $\bar{i} \cdot \bar{j} = 0$ . Then

$$\bar{\omega} = \omega_1 \bar{i} - \dot{\theta} \bar{j}' + \omega_z \bar{k}, \quad \bar{\omega}' = \omega_1 \bar{i}, \quad \bar{\alpha} = \dot{\omega}_1 \bar{i} - \ddot{\theta} \bar{j}' - \dot{\theta} (\bar{\omega}' \times \bar{j}') + \omega_z (\bar{\omega}' \times \bar{k})$$

$$\text{Set } \theta = 120^\circ \Rightarrow \bar{i} = \cos 30^\circ \bar{i} - \sin 30^\circ \bar{k}, \quad \bar{j}' = \bar{j}$$

$$\bar{\omega} = \omega_1 (0.8660 \bar{i} - 0.50 \bar{k}) - \dot{\theta} \bar{j} + \omega_z \bar{k} = 8.66 \bar{i} - 6 \bar{j} + 623.3 \bar{k} \text{ rad/s} \quad \triangleleft$$

$$\bar{\omega}' = \omega_1 (0.8660 \bar{i} - 0.50 \bar{k}) = 8.66 \bar{i} - 5.0 \bar{k}$$

$$\bar{\alpha} = \dot{\omega}_1 (0.8660 \bar{i} - 0.50 \bar{k}) - \ddot{\theta} \bar{j} - \dot{\theta} (8.66 \bar{i} - 5.0 \bar{k}) \times \bar{j}$$

$$+ (8.66 \bar{i} - 6 \bar{j} + 623.3 \bar{k}) \times \bar{k} = -3713 \bar{i} - 5351 \bar{j} - 102 \bar{k} \text{ rad/s}^2 \quad \triangleleft$$

## 4.2 HW 2

## 4.2.1 Problem 1

## EMA 542

## Home Work to be Handed In

- 3) A motor and attached rod  $AB$  have the angular motion shown in the figure below. A collar  $C$  on the rod is located 0.25 m from  $A$ , and is moving downward with a velocity of 3 m/s and an acceleration of 2 m/s<sup>2</sup>. Determine the velocity and acceleration of  $C$  at this instant.

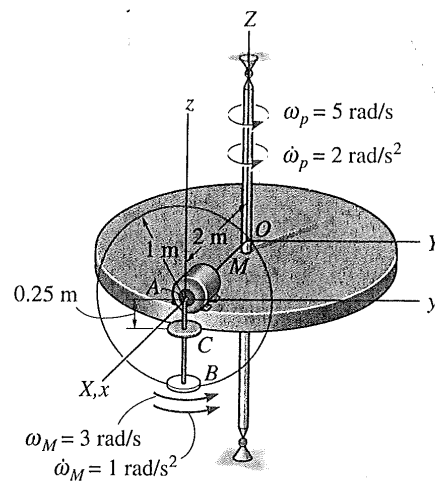

The local body coordinates frame is as follows

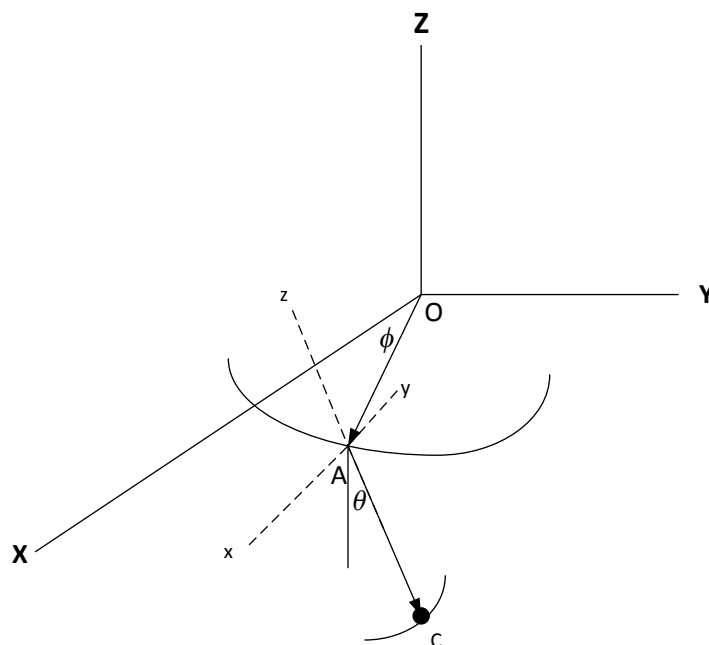

Note on notations used;  $\vec{r}_{C/O}$  is vector of point  $C$  in space. This vector originates from point  $O$  to point  $C$ .

$O$  always represents the inertial frame of reference.  $\vec{r}_{C/A}$  is a vector from point  $A$  to point  $C$ . In this problem there are two frames of references used. The inertial frame of reference  $XYZ$  whose origin is  $O$ , and the local body frame of reference  $xyz$  whose origin is point  $A$ . The unit vectors for  $XYZ$  are called  $i, j, k$  while unit vectors for local coordinates frame are  $\vec{e}_x, \vec{e}_y, \vec{e}_z$ . The following is a list of complete notations used in this problem

1.  $\vec{r}_{A/O}$  is vector of  $A$
2.  $\vec{r}_{C/O}$  is vector of  $C$
3.  $\vec{r}_{C/A}$  is vector from  $A$  to  $C$
4.  $\dot{\vec{r}}_{C/A}$  relative velocity of position vector  $\vec{r}_{C/A}$  as seen in local frame of reference
5.  $\vec{\omega}_{A/O}$  is the angular velocity of coordinate system  $xyz$ , whose origin is  $A$ , as seen in inertial frame  $XYZ$
6.  $L$  is the length of the radius of the disk, which is given as  $2m$
7.  $L_1(t)$  is the current length from  $A$  of point  $C$ . At the instance required, it is  $0.25m$

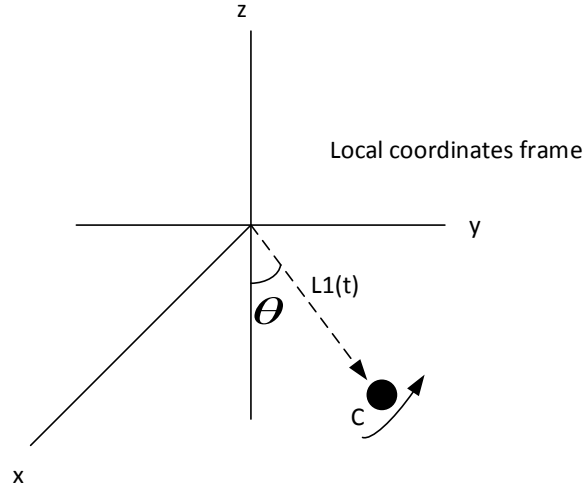

Given the above, then, by standard vector additions

$$\vec{r}_{C/O} = \vec{r}_{C/A} + \vec{r}_{A/O}$$

Hence, taking derivatives

$$\dot{\vec{r}}_{C/O} = \dot{\vec{r}}_{C/A} + (\vec{\omega}_{A/O} \times \vec{r}_{C/A}) + \dot{\vec{r}}_{A/O} \quad (1)$$

Where

$$\vec{r}_{A/O} = L \cos \phi \vec{i} + L \sin \phi \vec{j}$$

And taking derivatives of the above

$$\dot{\vec{r}}_{A/O} = -L\dot{\phi} \sin \phi \vec{i} + L\dot{\phi} \cos \phi \vec{j}$$

The position vector of C written using local coordinates system is

$$\vec{r}_{C/A} = 0\vec{e}_x - L_1 \cos \theta \vec{e}_z + L_1 \sin \theta \vec{e}_y$$

Taking derivatives

$$\dot{\vec{r}}_{C/A} = -(\dot{L}_1 \cos \theta - L_1 \dot{\theta} \sin \theta) \vec{e}_z + (\dot{L}_1 \sin \theta + L_1 \dot{\theta} \cos \theta) \vec{e}_y \quad (2)$$

And the following term is added to account for the fact that the local frame of reference itself is rotating relative to the inertial frame of reference

$$\vec{\omega}_{A/O} \times \vec{r}_{C/A} = \omega_p \vec{k} \times (-L_1 \cos \theta \vec{e}_z + L_1 \sin \theta \vec{e}_y)$$

Substituting the above back to Eq.(1) results in

$$\begin{aligned}\dot{\vec{r}}_{C/O} = & -\left(\dot{L}_1 \cos \theta - L_1 \dot{\theta} \sin \theta\right) \vec{e}_z + \left(\dot{L}_1 \sin \theta + L_1 \dot{\theta} \cos \theta\right) \vec{e}_y \\ & + \left(\omega_p \vec{k} \times \left(-L_1 \cos \theta \vec{e}_z + L_1 \sin \theta \vec{e}_y\right)\right) + \left(-L \dot{\phi} \sin \phi \vec{i} + L \dot{\phi} \cos \phi \vec{j}\right)\end{aligned}$$

At the instance given,  $\theta = 0, L_1 = 0.25m, \dot{L}_1 = 3m/s, \ddot{L}_1 = 2m/s^2, \dot{\theta} = \omega_m = 3rad/sec, \ddot{\theta} = \dot{\omega}_m = 1 rad/sec, L = 2 m, \vec{e}_z = \vec{k}$  and  $\vec{e}_y = \vec{j}, \omega_p = 5 rad.sec$ , The above simplifies to

$$\begin{aligned}\dot{\vec{r}}_{C/O} = & -\dot{L}_1 \vec{e}_z + L_1 \dot{\theta} \vec{e}_y + \left(\omega_p \vec{k} \times \left(-L_1 \vec{e}_z\right)\right) + L \omega_p \vec{j} \\ = & -3 \vec{e}_z + 0.25 \omega_m \vec{e}_y - \left(\omega_p \vec{k} \times 0.25 \vec{e}_z\right) + 2 \omega_p \vec{j}\end{aligned}$$

In addition, at the instance shown,  $\vec{e}_z = \vec{k}$  and  $\vec{e}_y = \vec{j}$  (but this is only at the instance given. In general it is not the case). The above simplifies to

$$\begin{aligned}\dot{\vec{r}}_{C/O} = & -3 \vec{k} + 0.25 \omega_m \vec{j} - \left(\omega_p \vec{k} \times 0.25 \vec{k}\right) + 2 \omega_p \vec{j} \\ = & -3 \vec{k} + 0.25 \omega_m \vec{j} + 2 \omega_p \vec{j} \\ = & -3 \vec{k} + 0.75 \vec{j} + 10 \vec{j} \\ = & 10.75 \vec{j} - 3 \vec{k} \quad [m/s]\end{aligned}$$

Numerically, the magnitude of the velocity vector is

$$\left|\dot{\vec{r}}_{C/O}\right| = \sqrt{10.75^2 + 9} = 11.161 \text{ m/s}$$

To find the acceleration, derivative of Eq. (1) is now taken

$$\begin{aligned}\dot{\vec{r}}_{C/O} = & \dot{\vec{r}}_{C/A} + \left(\vec{\omega}_{A/O} \times \vec{r}_{C/A}\right) + \dot{\vec{r}}_{A/O} \\ a = & \ddot{\vec{r}}_{C/A} + \left(\vec{\omega}_{A/O} \times \dot{\vec{r}}_{C/A}\right) + \left(\dot{\vec{\omega}}_{A/O} \times \vec{r}_{C/A} + \omega_{A/O} \times \left(\dot{\vec{r}}_{C/A} + \omega_{A/O} \times \vec{r}_{C/A}\right)\right) + \ddot{\vec{r}}_{A/O} \\ = & \ddot{\vec{r}}_{C/A} + \left(\omega_{A/O} \times \dot{\vec{r}}_{C/A}\right) + \dot{\vec{\omega}}_{A/O} \times \vec{r}_{C/A} + \omega_{A/O} \times \dot{\vec{r}}_{C/A} + \omega_{A/O} \times \left(\omega_{A/O} \times \vec{r}_{C/A}\right) + \ddot{\vec{r}}_{A/O} \\ = & \ddot{\vec{r}}_{C/A} + 2\left(\omega_{A/O} \times \dot{\vec{r}}_{C/A}\right) + \left(\dot{\vec{\omega}}_{A/O} \times \vec{r}_{C/A}\right) + \omega_{A/O} \times \left(\omega_{A/O} \times \vec{r}_{C/A}\right) + \ddot{\vec{r}}_{A/O} \quad (3)\end{aligned}$$

$\ddot{\vec{r}}_{C/A}$  is found by differentiating Eq. (2) in the local frame giving

$$\begin{aligned}\dot{\vec{r}}_{C/A} &= -\left(\dot{L}_1 \cos \theta - L_1 \dot{\theta} \sin \theta\right) \vec{e}_z + \left(\dot{L}_1 \sin \theta + L_1 \dot{\theta} \cos \theta\right) \vec{e}_y \\ \ddot{\vec{r}}_{C/A} &= -\left(\ddot{L}_1 \cos \theta - \dot{L}_1 \dot{\theta} \sin \theta\right) \vec{e}_z + \left(\dot{L}_1 \dot{\theta} \sin \theta + L_1 \ddot{\theta} \sin \theta + L_1 \dot{\theta}^2 \cos \theta\right) \vec{e}_z \\ &\quad + \left(\ddot{L}_1 \sin \theta + \dot{L}_1 \dot{\theta} \cos \theta + \dot{L}_1 \dot{\theta} \cos \theta + L_1 \ddot{\theta} \cos \theta - L_1 \dot{\theta}^2 \sin \theta\right) \vec{e}_y\end{aligned}$$

At the instance given the above becomes

$$\begin{aligned}\ddot{\vec{r}}_{C/A} &= -2\vec{k} + 0.25\omega_m^2 \vec{k} + \left(3\omega_m + 3\omega_m + 0.25\dot{\omega}_m\right) \vec{j} \\ &= -2\vec{k} + 0.25(9) \vec{k} + (9 + 9 + 0.25) \vec{j} \\ &= 18.25 \vec{j} + 0.25 \vec{k}\end{aligned}$$

And

$$\begin{aligned}\dot{\vec{r}}_{C/A} &= -\left(\dot{L}_1 \cos \theta - L_1 \dot{\theta} \sin \theta\right) \vec{e}_z + \left(\dot{L}_1 \sin \theta + L_1 \dot{\theta} \cos \theta\right) \vec{e}_y \\ &= 0.75 \vec{j} - 3 \vec{k}\end{aligned}$$

And

$$\begin{aligned}\vec{r}_{C/A} &= 0 \vec{e}_x - L_1 \cos \theta \vec{e}_z + L_1 \sin \theta \vec{e}_y \\ &= -0.25 \vec{k}\end{aligned}$$

And

$$\begin{aligned}\dot{\vec{r}}_{A/O} &= -L\dot{\phi} \sin \phi \vec{i} + L\dot{\phi} \cos \phi \vec{j} \\ \ddot{\vec{r}}_{A/O} &= -\left(L\ddot{\phi} \sin \phi + L\dot{\phi}^2 \cos \phi\right) \vec{i} + \left(L\ddot{\phi} \cos \phi - L\dot{\phi}^2 \sin \phi\right) \vec{j}\end{aligned}$$

Hence at the instance given

$$\begin{aligned}\ddot{\vec{r}}_{A/O} &= -L\dot{\phi}^2 \vec{i} + L\ddot{\phi} \vec{j} \\ &= -2\omega_p^2 \vec{i} + 2\dot{\omega}_p \vec{j} \\ &= -50 \vec{i} + 4 \vec{j}\end{aligned}$$

And

$$\begin{aligned}\vec{\omega}_{A/O} &= \omega_p \vec{k} \\ &= 5 \vec{k} \text{ rad/sec}\end{aligned}$$

And

$$\begin{aligned}\dot{\vec{\omega}}_{A/O} &= \dot{\omega}_p \vec{k} \\ &= 2\vec{k} \text{ rad/sec}^2\end{aligned}$$

And

$$\begin{aligned}\vec{r}_{C/A} &= 0\vec{e}_x - L_1 \cos \theta \vec{e}_z + L_1 \sin \theta \vec{e}_y \\ &= -0.25\vec{k}\end{aligned}$$

Therefore, Eq. (3) becomes

$$\begin{aligned}a &= \ddot{\vec{r}}_{C/A} + 2\left(\vec{\omega}_{A/O} \times \dot{\vec{r}}_{C/A}\right) + \left(\dot{\vec{\omega}}_{A/O} \times \vec{r}_{C/A}\right) + \vec{\omega}_{A/O} \times \left(\vec{\omega}_{A/O} \times \vec{r}_{C/A}\right) + \ddot{\vec{r}}_{A/O} \\ &= \left(18.25\vec{j} + 0.25\vec{k}\right) + 2\left(5\vec{k} \times \left(0.75\vec{j} - 3\vec{k}\right)\right) + \left(2\vec{k} \times \left(-0.25\vec{k}\right)\right) \\ &\quad + 5\vec{k} \times \left(5\vec{k} \times \left(-0.25\vec{k}\right)\right) + \left(-50\vec{i} + 4\vec{j}\right) \\ &= 18.25\vec{j} + 0.25\vec{k} + 2\left(5\vec{k} \times 0.75\vec{j} - 5\vec{k} \times 3\vec{k}\right) - 50\vec{i} + 4\vec{j} \\ &= 18.25\vec{j} + 0.25\vec{k} + 2\left(5\vec{k} \times 0.75\vec{j}\right) - 50\vec{i} + 4\vec{j} \\ &= 18.25\vec{j} + 0.25\vec{k} + 2\left(-3.75\vec{i}\right) - 50\vec{i} + 4\vec{j} \\ &= -107.5\vec{i} + 22.25\vec{j} + 0.25\vec{k}\end{aligned}$$

Hence

$$\begin{aligned}|a| &= \sqrt{107.5^2 + 22.25^2 + 0.25^2} \\ &= 109.78 \quad m/s^2\end{aligned}$$



## 4.2.2 problem 2

EMA 542

Home Work to be Handed In

- 3A) The circular cylindrical shell (shown) of radius  $R$  rotates about a vertical axis at the angular velocity  $\omega = 3t^2$ . The shape of an oil line going from the axis of rotation ( $y$  axis) to the outer surface of the shell is given by  $y = \frac{1}{2}(3 + x^2)$  where the  $xyz$  axes are body axes described by the rotating  $\vec{i}, \vec{j}, \vec{k}$  unit vectors as shown. Oil flows outward along the oil line at a constant speed of  $s = 2.0$  ft/sec. relative to the oil line. Determine the total velocity of the oil particle  $P$  that is instantaneously located at 1.0 ft. radially outward from the  $y$  axis at time 2.0 sec. Give answers in terms of  $\vec{i}, \vec{j}, \vec{k}$  components. Use the equation  $\vec{A}_R = \vec{A}_r + \vec{\omega}_{cs} \times \vec{A}$  to get your answer.

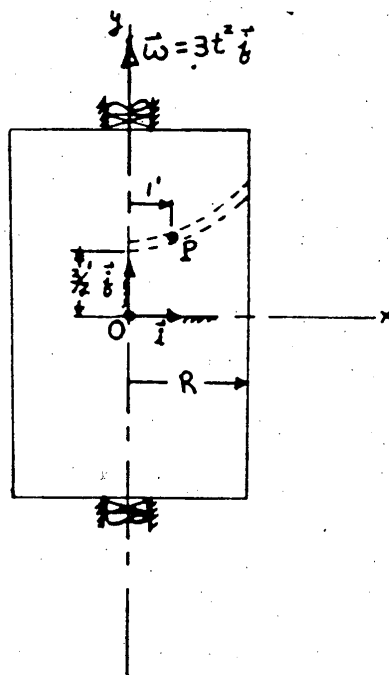

Note on notations used;  $\vec{r}_{P/O}$  is vector of point  $P$  in space that originates from point  $O$ , which is the origin of the inertial frame of reference.  $O$  always represents the inertial frame of reference. Hence  $\vec{r}_{P/A}$  is a vector from point  $A$  to point  $P$ . In this problem there are two frames of references used. The inertial frame of reference  $XYZ$  whose origin is called  $O$ , and the local body frame of reference  $xyz$  attached to point  $A$  which in this problem happens to be the same as  $O$  point shown above. Hence the origin of  $xyz$  is  $A$ . The unit vectors for  $XYZ$  are always called  $\vec{i}, \vec{j}, \vec{k}$  while unit vectors for local coordinates frame are  $\vec{e}_x, \vec{e}_y, \vec{e}_z$ . The following is a list of complete notations used in this problem

1.  $\vec{r}_{P/A}$  is vector from  $A$  to  $P$
2.  $\vec{\omega}_{A/O}$  is the angular velocity of vector coordinate system  $xyz$ , whose origin is  $A$ , as seen in inertial frame  $XYZ$
3.  $y(x)$  is the  $y$  coordinates of point  $P$  as seen in local coordinates system
4.  $x$  is the  $x$  coordinates of point  $P$  as seen in local coordinates system

Let  $p$  be the point, and as seen in the local frame  $xyz$  it will appear as follows

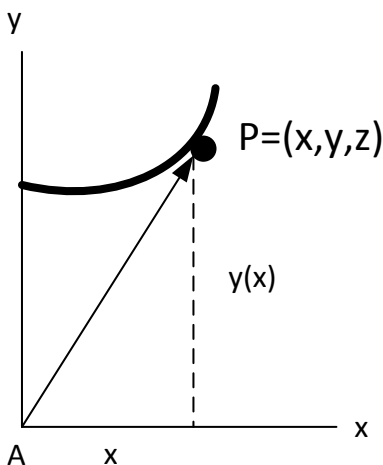

Using vector addition,

$$\vec{r}_{P/O} = \vec{r}_{P/A} + \vec{r}_{A/O}$$

Where, the position of  $p$  expressed in local frame is

$$\begin{aligned} \vec{r}_{P/A} &= 0\vec{e}_z + x(t)\vec{e}_x + y(t)\vec{e}_y \\ &= x(t)\vec{e}_x + \frac{1}{2}(3+x^2)\vec{e}_y \end{aligned} \quad (4.1)$$

But

$$\begin{aligned} ds &= \sqrt{dx^2 + dy^2} \\ \frac{ds}{dt} &= \sqrt{\left(\frac{dx}{dt}\right)^2 + \left(\frac{dy}{dt}\right)^2} \\ &= \sqrt{\left(\frac{dx}{dt}\right)^2 + \left(\frac{dy}{dx} \frac{dx}{dt}\right)^2} \\ &= \left(\frac{dx}{dt}\right) \sqrt{1 + \left(\frac{dy}{dx}\right)^2} \end{aligned}$$

But  $\frac{dy}{dx} = \frac{d}{dx} \left( \frac{1}{2} (3 + x^2) \right) = x$ , hence the above becomes

$$\frac{ds}{dt} = \dot{x} \sqrt{1 + x^2}$$

But  $\frac{ds}{dt}$  is constant and given by 2 ft/sec, therefore

$$\begin{aligned} 2 &= \dot{x} \sqrt{1 + x^2} \\ \dot{x} &= \frac{2}{\sqrt{1 + x^2}} \end{aligned}$$

And since

$$\begin{aligned} \frac{dy}{dt} &= \frac{dy}{dx} \frac{dx}{dt} \\ &= x \dot{x} \end{aligned}$$

Hence

$$\dot{y} = \frac{2x}{\sqrt{1 + x^2}}$$

Now taking derivatives of Eq. (1), and noting that  $\dot{\vec{r}}_{A/O} = 0$  since the origin of the local frame coincides with the origin of the inertial frame, hence  $\vec{r}_{A/O} = \vec{0}$

$$\begin{aligned} \dot{\vec{r}}_{P/O} &= \dot{\vec{r}}_{P/A} + (\vec{\omega}_{A/O} \times \vec{r}_{P/A}) + \dot{\vec{r}}_{A/O} \\ &= (\dot{x} \vec{e}_x + \dot{y} \vec{e}_y) + (\omega(t) \vec{j} \times (x(t) \vec{e}_x + y(t) \vec{e}_y)) + \vec{0} \end{aligned} \quad (2)$$

At the instance shown,  $\vec{e}_x$  is aligned with  $\vec{i}$  and  $\vec{e}_y$  is aligned with  $\vec{j}$ , hence the above becomes

$$\begin{aligned} \dot{\vec{r}}_{P/O} &= (\dot{x} \vec{i} + \dot{y} \vec{j}) + (\omega \vec{j} \times x(t) \vec{i}) + (\omega \vec{j} \times y(t) \vec{j}) \\ &= (\dot{x} \vec{i} + \dot{y} \vec{j}) - \omega x(t) \vec{k} \end{aligned}$$

Substituting for  $\dot{x}, \dot{y}$  in the above

$$\dot{\vec{r}}_{P/O} = \left( \frac{2}{\sqrt{1 + x^2}} \vec{i} + \frac{2x}{\sqrt{1 + x^2}} \vec{j} \right) - 3t^2 x(t) \vec{k}$$

At this instance,  $t = 2$  sec,  $x = 1$ ft, hence

$$\begin{aligned} \dot{\vec{r}}_{P/O} &= \frac{2}{\sqrt{2}} \vec{i} + \frac{2}{\sqrt{2}} \vec{j} - 3(4) \vec{k} \quad [ft/sec] \\ &= 1.414 \vec{i} + 1.414 \vec{j} - 12 \vec{k} \end{aligned}$$

and

$$\begin{aligned} \left| \dot{\vec{r}}_{P/O} \right| &= \sqrt{\left(\frac{2}{\sqrt{2}}\right)^2 + \left(\frac{2}{\sqrt{2}}\right)^2 + 12^2} \\ &= 12.166 \quad ft/sec \end{aligned}$$

#### 4.2.2.1 Extra (finding the acceleration)

This is not required, but for practice. Now the total acceleration is found. From Eq. (2) above it was found that

$$\dot{\vec{r}}_{P/O} = \dot{\vec{r}}_{P/A} + (\vec{\omega}_{A/O} \times \vec{r}_{P/A}) + \dot{\vec{r}}_{A/O}$$

Taking derivative of the above

$$\begin{aligned} \ddot{\vec{r}}_{P/O} &= \ddot{\vec{r}}_{P/A} + \left( \vec{\omega}_{A/O} \times \dot{\vec{r}}_{P/A} \right) + \left( \dot{\vec{\omega}}_{A/O} \times \vec{r}_{P/A} + \vec{\omega}_{A/O} \times \left( \dot{\vec{r}}_{P/A} + (\vec{\omega}_{A/O} \times \vec{r}_{P/A}) \right) \right) + \ddot{\vec{r}}_{A/O} \\ &= \ddot{\vec{r}}_{P/A} + \left( \vec{\omega}_{A/O} \times \dot{\vec{r}}_{P/A} \right) + \left( \dot{\vec{\omega}}_{A/O} \times \vec{r}_{P/A} + \vec{\omega}_{A/O} \times \dot{\vec{r}}_{P/A} + \vec{\omega}_{A/O} \times (\vec{\omega}_{A/O} \times \vec{r}_{P/A}) \right) + \ddot{\vec{r}}_{A/O} \\ &= \ddot{\vec{r}}_{P/A} + 2 \left( \vec{\omega}_{A/O} \times \dot{\vec{r}}_{P/A} \right) + \dot{\vec{\omega}}_{A/O} \times \vec{r}_{P/A} + \vec{\omega}_{A/O} \times (\vec{\omega}_{A/O} \times \vec{r}_{P/A}) + \ddot{\vec{r}}_{A/O} \end{aligned} \quad (4)$$

But

$$\vec{r}_{P/A} = x(t) \vec{e}_x + \frac{1}{2} (3 + x^2) \vec{e}_y$$

Hence

$$\dot{\vec{r}}_{P/A} = \dot{x} \vec{e}_x + \dot{y} \vec{e}_y$$

And

$$\ddot{\vec{r}}_{P/A} = \ddot{x} \vec{e}_x + \ddot{y} \vec{e}_y$$

And

$$\left( \vec{\omega}_{A/O} \times \dot{\vec{r}}_{P/A} \right) = \omega(t) \vec{j} \times \left( \dot{x} \vec{e}_x + \dot{y} \vec{e}_y \right)$$

And

$$\begin{aligned} \dot{\vec{\omega}}_{A/O} \times \vec{r}_{P/A} &= \frac{d}{dt} 3t^2 \vec{j} \times \left( x(t) \vec{e}_x + \frac{1}{2} (3 + x^2) \vec{e}_y \right) \\ &= 6t \vec{j} \times \left( x(t) \vec{e}_x + \frac{1}{2} (3 + x^2) \vec{e}_y \right) \end{aligned}$$

And

$$\vec{\omega}_{A/O} \times \vec{r}_{P/A} = \omega(t) \vec{j} \times \left( x(t) \vec{e}_x + y(t) \vec{e}_y \right)$$

And

$$\vec{\omega}_{A/O} \times (\vec{\omega}_{A/O} \times \vec{r}_{P/A}) = \omega(t) \vec{j} \times (\omega(t) \vec{j} \times (x(t) \vec{e}_x + y(t) \vec{e}_y))$$

And since  $A$  is attached to  $O$ , hence

$$\ddot{\vec{r}}_{A/O} = 0$$

Now the above is evaluated at the instance given where,  $\vec{e}_x$  is aligned with  $\vec{i}$  and  $\vec{e}_y$  is aligned with  $\vec{j}$ , hence Eq. (4) becomes

$$\ddot{\vec{r}}_{P/O} = \ddot{x} \vec{i} + \ddot{y} \vec{j} + 2(\omega \vec{j} \times (\dot{x} \vec{i} + \dot{y} \vec{j})) + \left(6t \vec{j} \times \left(x \vec{i} + \frac{1}{2}(3+x^2) \vec{j}\right)\right) + \omega \vec{j} \times (\omega \vec{j} \times (x \vec{i} + y \vec{j}))$$

At the instance shown  $x = 1$  ft,  $t = 2$  sec and hence  $\omega = 3t^2 = 12$  rad/sec. Since speed of particle is constant, then  $\ddot{x} = 0$  and  $\ddot{y} = 0$ , then the above simplifies to

$$\begin{aligned} \ddot{\vec{r}}_{P/O} &= 2 \left( 12 \vec{j} \times \left( \frac{2}{\sqrt{2}} \vec{i} + \frac{2}{\sqrt{2}} \vec{j} \right) \right) + \left( 12 \vec{j} \times (\vec{i} + 2 \vec{j}) \right) + 12 \vec{j} \times \left( 12 \vec{j} \times (\vec{i} + 2 \vec{j}) \right) \\ &= 2 \left( \left( 12 \vec{j} \times \frac{2}{\sqrt{2}} \vec{i} \right) + \left( 12 \vec{j} \times \frac{2}{\sqrt{2}} \vec{j} \right) \right) + \left( 12 \vec{j} \times \vec{i} \right) \\ &\quad + \left( 12 \vec{j} \times 2 \vec{j} \right) + 12 \vec{j} \times \left( \left( 12 \vec{j} \times \vec{i} \right) + \left( 12 \vec{j} \times 2 \vec{j} \right) \right) \\ &= 2 \left( -\frac{24}{\sqrt{2}} \vec{k} \right) - 12 \vec{k} + 12 \vec{j} \times (-12 \vec{k}) \\ &= -\frac{48}{\sqrt{2}} \vec{k} - 12 \vec{k} - 144 \vec{i} \\ &= -144 \vec{i} - 45.941 \vec{k} \end{aligned}$$

Hence

$$\left| \ddot{\vec{r}}_{P/O} \right| = \sqrt{144^2 + 45.941^2} = 151.15 \text{ m/sec}^2$$

## 4.2.3 key solution

## EMA 542

## Home Work to be Handed In

- 3) A motor and attached rod  $AB$  have the angular motion shown in the figure below. A collar  $C$  on the rod is located 0.25 m from  $A$ , and is moving downward with a velocity of 3 m/s and an acceleration of  $2 \text{ m/s}^2$ . Determine the velocity and acceleration of  $C$  at this instant.

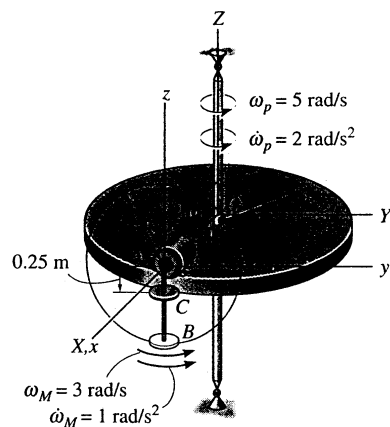

NOTICE: This MATERIAL MAY  
BE PROTECTED BY  
Copyright Law (Title 17 US Code)

## SOLUTION TO 3

ATTACH XYZ TO PLATFORM AT A

$$\vec{\omega} = 5\vec{k} \quad \dot{\vec{R}} = 10\vec{j} \quad \vec{\rho} = -.25\vec{k}$$

$$\vec{V}_c = \dot{\vec{R}} + \vec{\omega} \times \vec{\rho} + \dot{\vec{\rho}}_r$$

$$\underline{\vec{\omega} \times \vec{\rho}} = 5\vec{k} \times -.25\vec{k} = 0$$

USE POLAR COORDS.:

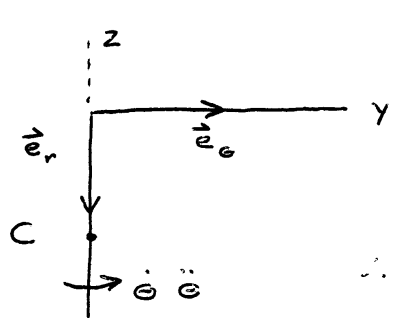

$$\begin{aligned} \dot{\vec{\rho}}_r &= \dot{r} \vec{e}_r + r \dot{\theta} \vec{e}_\theta \\ &= -3\vec{k} + (.25)3\vec{j} \end{aligned}$$

$$\therefore \underline{\dot{\vec{\rho}}_r} = .75\vec{j} - 3\vec{k}$$

$$\therefore \underline{\vec{V}_c} = 10.75\vec{j} - 3\vec{k}$$

$$\vec{a}_c = \ddot{\vec{R}} + \vec{\omega} \times (\vec{\omega} \times \vec{\rho}) + \dot{\vec{\omega}} \times \vec{\rho} + 2\vec{\omega} \times \dot{\vec{\rho}}_r + \ddot{\vec{\rho}}_r$$

$$\ddot{\vec{R}} = 2(2)\vec{j} - 2(5)^2\vec{x}$$

$$\underline{\ddot{\vec{R}}} = -50\vec{x} + 4\vec{j}$$

- 2 -

$$\underline{\vec{\omega} \times (\vec{\omega} \times \vec{r})} = 5\bar{k} \times 0 = 0$$

$$\vec{\omega} = 2\bar{k} \quad \therefore \underline{\vec{\omega} \times \dot{\vec{r}}} = 2\bar{k} \times .25\bar{k} = 0$$

$$2\vec{\omega} \times \dot{\vec{r}}_r = 2(5)\bar{k} \times [.75\bar{j} - 3\bar{i}]$$

$$\underline{2\vec{\omega} \times \dot{\vec{r}}_r} = -7.5\bar{x}$$

$$\ddot{\vec{r}}_r = (\ddot{r} - r\dot{\theta}^2)\vec{e}_r + (r\ddot{\theta} + 2\dot{r}\dot{\theta})\vec{e}_\theta$$

$$= -[2 - (.25)(3)^2]\bar{k} + [(.25)(1) + 2(3)(3)]\bar{j}$$

$$\Rightarrow \underline{\ddot{\vec{r}}_r} = .25\bar{k} + 18.25\bar{j}$$

$$\therefore \vec{a}_c = [-50 - 7.5]\bar{x} + [4 + 18.25]\bar{j} + .25\bar{k}$$

$$\therefore \boxed{\vec{a}_c = -57.5\bar{x} + 22.5\bar{j} + .25\bar{k}}$$



## EMA 542

## Home Work to be Handed In

- 3A) The circular cylindrical shell (shown) of radius  $R$  rotates about a vertical axis at the angular velocity  $\omega = 3t^2$ . The shape of an oil line going from the axis of rotation ( $y$  axis) to the outer surface of the shell is given by  $y = \frac{1}{2}(3 + x^2)$  where the  $xyz$  axes are body axes described by the rotating  $\vec{i}, \vec{j}, \vec{k}$  unit vectors as shown. Oil flows outward along the oil line at a constant speed of  $s = 2.0$  ft/sec. relative to the oil line. Determine the total velocity of the oil particle  $P$  that is instantaneously located at 1.0 ft. radially outward from the  $y$  axis at time 2.0 sec. Give answers in terms of  $\vec{i}, \vec{j}, \vec{k}$  components. Use the equation  $\vec{A}_R = \dot{\vec{A}} + \vec{\omega}_{cs} \times \vec{A}$  to get your answer.

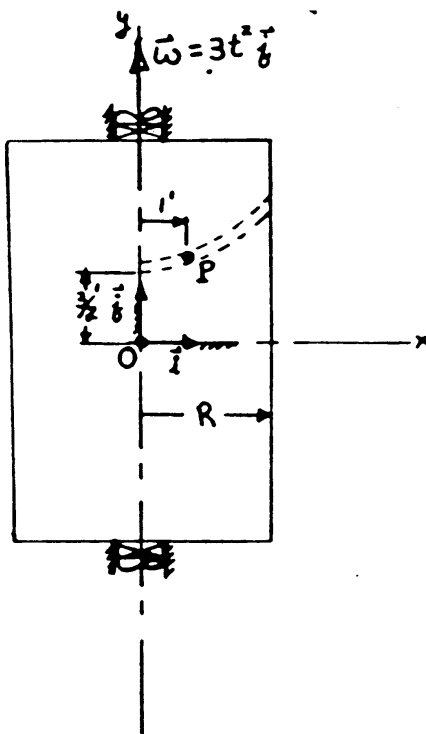

HomeworkSolution to Problem 7 using Eqs. (1-63) and (1-66)

$$\vec{\omega} = 3t^2 \vec{j} \quad \vec{\dot{\omega}} = 6t \vec{j} \quad (a) \quad \vec{v}_P = \vec{v}_O + \vec{\omega}_{cs} \times \vec{\rho} + \dot{\vec{\rho}}_r$$

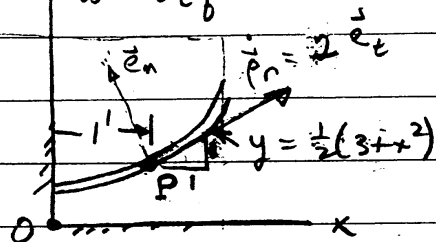
where  $\vec{v}_O = 0$ 

$$\left. \begin{aligned} \vec{\omega}_{cs} &= 12 \vec{j} \\ \vec{\rho} &= \vec{i} + 2 \vec{j} \end{aligned} \right\} \vec{\omega}_{cs} \times \vec{\rho} = -12 \vec{k}$$

$$\vec{\rho}_r = 2 \vec{e}_t = \sqrt{2} \vec{i} + \sqrt{2} \vec{j}$$

Important Data

$$y = \frac{3}{2} + x^2; \quad y|_{x=1} = 2$$

$$\frac{dy}{dx} = 2x; \quad \left. \frac{dy}{dx} \right|_{x=1} = 2$$

$$\frac{d^2y}{dx^2} = 2; \quad \left. \frac{d^2y}{dx^2} \right|_{x=1} = 2$$

$$\vec{e}_t = \frac{1}{\sqrt{2}} \vec{i} + \frac{1}{\sqrt{2}} \vec{j}; \quad \vec{e}_n = -\frac{1}{\sqrt{2}} \vec{i} + \frac{1}{\sqrt{2}} \vec{j}$$

$$\vec{v}_P = \sqrt{2} \vec{i} + \sqrt{2} \vec{j} - 12 \vec{k}$$

$$(b) \quad \vec{a}_P = \vec{a}_O + \vec{\omega}_{cs} \times (\vec{\omega}_{cs} \times \vec{\rho}) + \dot{\vec{\omega}} \times \vec{\rho} + \dot{\vec{\rho}}_r + 2\vec{\omega} \times \dot{\vec{\rho}}_r$$

where

$$\vec{a}_O = 0$$

$$\vec{\omega}_{cs} \times (\vec{\omega}_{cs} \times \vec{\rho}) = 12 \vec{j} \times (-12 \vec{k}) = -144 \vec{i}$$

$$\dot{\vec{\omega}} \times \vec{\rho} = 6 \vec{j} \times (\vec{i} + 2 \vec{j}) = -6 \vec{k}$$

$$\dot{\vec{\rho}}_r = \dot{\rho} \vec{e}_n = \frac{4}{2\sqrt{2}} \vec{e}_n = \frac{2}{\sqrt{2}} \vec{e}_n = \sqrt{2} \vec{e}_n = -\vec{i} + \vec{j}$$

$$\text{where } \rho = \frac{[1 + (\frac{dy}{dx})^2]^{1/2}}{\frac{dy}{dx}} = \frac{[1 + 4]^{1/2}}{2} = \frac{\sqrt{5}}{2} = 2\sqrt{2} = 2.828$$

$$2\vec{\omega} \times \dot{\vec{\rho}}_r = 2(12 \vec{j}) \times [\sqrt{2} \vec{e}_n] = -24\sqrt{2} \vec{k} = -33.9 \vec{k}$$

$$\vec{a}_P = -145 \vec{i} + \vec{j} - 45.9 \vec{k}$$



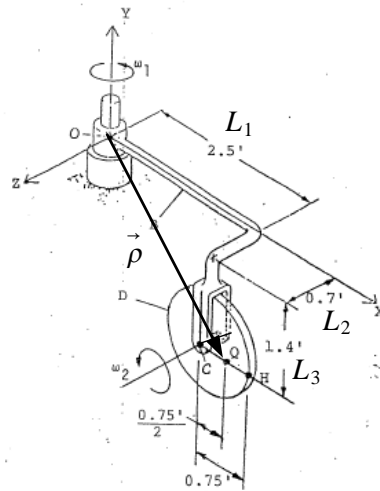

$\rho$  is vector that represents the position of point Q on the disk relative to the rotating frame. Let current distance of point Q from center of disk be  $r(t)$  and angle be  $\theta(t)$  where  $\dot{\theta}(t) = \omega_2$  as shown in this diagram

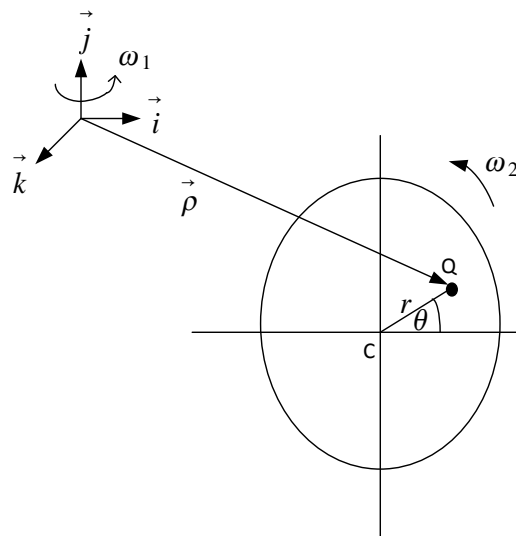

The position of Q as seen in inertial frame is therefore

$$\vec{r}_Q = \vec{R} + \vec{\rho} \quad (1)$$

But  $\vec{R} = 0$  here. And

$$\rho = (L_1 + r \cos \theta) \mathbf{i} + (-L_3 + r \sin \theta) \mathbf{j} + L_2 \mathbf{k}$$

Hence the total velocity is

$$\mathbf{V}_Q = \dot{\rho}_r + (\omega_1 \times \vec{\rho}) \quad (2)$$

Where

$$\begin{aligned} \dot{\rho}_r &= (\dot{r} \cos \theta - r\dot{\theta} \sin \theta) \mathbf{i} + (\dot{r} \sin \theta + r\dot{\theta} \cos \theta) \mathbf{j} \\ &= (\dot{r} \cos \theta - r\omega_2 \sin \theta) \mathbf{i} + (\dot{r} \sin \theta + r\omega_2 \cos \theta) \mathbf{j} \end{aligned}$$

and

$$\begin{aligned} \omega_1 \times \rho &= \omega_1 \mathbf{j} \times ((L_1 + r \cos \theta) \mathbf{i} + (-L_3 + r \sin \theta) \mathbf{j} + L_2 \mathbf{k}) \\ &= -\omega_1 (L_1 + r \cos \theta) \vec{\mathbf{k}} + \omega_1 L_2 \mathbf{i} \end{aligned}$$

Hence Eq. (2) becomes

$$\begin{aligned} \mathbf{V}_Q &= (\dot{r} \cos \theta - r\omega_2 \sin \theta) \mathbf{i} + (\dot{r} \sin \theta + r\omega_2 \cos \theta) \mathbf{j} - \omega_1 (L_1 + r \cos \theta) \mathbf{k} + \omega_1 L_2 \mathbf{i} \\ &= (\dot{r} \cos \theta - r\omega_2 \sin \theta + \omega_1 L_2) \mathbf{i} + (\dot{r} \sin \theta + r\omega_2 \cos \theta) \mathbf{j} - \omega_1 (L_1 + r \cos \theta) \mathbf{k} \end{aligned} \quad (3)$$

At the snapshot,  $\theta = 0$  and  $\dot{\theta} = \omega_2$  and  $r = \frac{0.75}{2} = 0.375$  ft, and  $\dot{r} = 1.5$  ft/sec,  $L_1 = 2.5$ ,  $L_2 = 0.7$ ,  $L_3 = 1.4$ ,  $\omega_2 = 0.5$  rad/sec,  $\omega_1 = 1.2$  rad/sec, Hence the above becomes

$$\mathbf{V}_Q = (\dot{r} + \omega_1 L_2) \mathbf{i} + r\omega_2 \mathbf{j} - \omega_1 (L_1 + r) \mathbf{k}$$

Now it is evaluated using the numerical values given

$$\begin{aligned} \mathbf{V}_Q &= (1.5 + 1.2(0.7)) \mathbf{i} + 0.375(0.5) \mathbf{j} - 1.2(2.5 + 0.375) \mathbf{k} \\ &= 2.34 \mathbf{i} + 0.1875 \mathbf{j} - 3.45 \mathbf{k} \end{aligned}$$

Hence

$$\begin{aligned} |\mathbf{V}_Q| &= \sqrt{2.34^2 + 0.1875^2 + 3.45^2} \\ &= 4.1729 \quad ft/sec \end{aligned}$$

To find absolute acceleration, the derivative of Eq. (2) is

$$\begin{aligned} \mathbf{a}_Q &= \frac{d}{dt} (\dot{\rho}_r + (\omega_1 \times \rho)) \\ &= \ddot{\rho}_r + (\omega_1 \times \dot{\rho}_r) + (\dot{\omega}_1 \times \rho) + (\omega_1 \times (\dot{\rho}_r + (\omega_1 \times \rho))) \\ &= \ddot{\rho}_r + 2(\omega_1 \times \dot{\rho}_r) + (\dot{\omega}_1 \times \rho) + (\omega_1 \times (\omega_1 \times \rho)) \end{aligned} \quad (5)$$

Each term in the above is now found

$$\begin{aligned} \ddot{\rho}_r &= \frac{d}{dt} [(\dot{r} \cos \theta - r\dot{\theta} \sin \theta) \mathbf{i} + (\dot{r} \sin \theta + r\dot{\theta} \cos \theta) \mathbf{j}] \\ &= ((\ddot{r} \cos \theta - \dot{r}\dot{\theta} \sin \theta) - (\dot{r}\dot{\theta} \sin \theta + r\ddot{\theta} \sin \theta + r\dot{\theta}^2 \cos \theta)) \mathbf{i} \\ &\quad + ((\ddot{r} \sin \theta + \dot{r}\dot{\theta} \cos \theta) + (\dot{r}\dot{\theta} \cos \theta + r\ddot{\theta} \cos \theta - r\dot{\theta}^2 \sin \theta)) \mathbf{j} \end{aligned}$$

Hence

$$\ddot{\rho}_r = (\ddot{r} \cos \theta - 2\dot{r}\dot{\theta} \sin \theta - r\ddot{\theta} \sin \theta - r\dot{\theta}^2 \cos \theta) \mathbf{i} + (\ddot{r} \sin \theta + 2\dot{r}\dot{\theta} \cos \theta + r\ddot{\theta} \cos \theta - r\dot{\theta}^2 \sin \theta) \mathbf{j}$$

And

$$\begin{aligned} \omega_1 \times \dot{\rho}_r &= \omega_1 \mathbf{j} \times ((\dot{r} \cos \theta - r\dot{\theta} \sin \theta) \mathbf{i} + (\dot{r} \sin \theta + r\dot{\theta} \cos \theta) \mathbf{j}) \\ &= -\omega_1 (\dot{r} \cos \theta - r\dot{\theta} \sin \theta) \mathbf{k} \end{aligned}$$

And

$$\begin{aligned} (\dot{\omega}_1 \times \rho) &= (\dot{\omega}_1 \mathbf{j} \times ((L_1 + r \cos \theta) \mathbf{i} + (-L_3 + r \sin \theta) \mathbf{j} + L_2 \mathbf{k})) \\ &= -\dot{\omega}_1 (L_1 + r \cos \theta) \mathbf{k} + (\dot{\omega}_1 L_2) \mathbf{i} \end{aligned}$$

And finally

$$\begin{aligned} \omega_1 \times (\vec{\omega}_1 \times \rho) &= \omega_1 \mathbf{j} \times (\omega_1 \mathbf{j} \times ((L_1 + r \cos \theta) \vec{\mathbf{i}} + (-L_3 + r \sin \theta) \mathbf{j} + L_2 \mathbf{k})) \\ &= \omega_1 \mathbf{j} \times (-\omega_1 (L_1 + r \cos \theta) \mathbf{k} + \omega_1 L_2 \mathbf{i}) \\ &= -\omega_1^2 (L_1 + r \cos \theta) \vec{\mathbf{i}} - \omega_1^2 L_2 \mathbf{k} \end{aligned}$$

Now all terms in Eq. (5) are known. Hence Eq. (5) becomes

$$\begin{aligned} \mathbf{a}_Q &= \ddot{\rho}_r + 2(\omega_1 \times \dot{\rho}_r) + (\dot{\omega}_1 \times \rho) + (\vec{\omega}_1 \times (\omega_1 \times \rho)) \\ &= (\ddot{r} \cos \theta - 2\dot{r}\dot{\theta} \sin \theta - r\ddot{\theta} \sin \theta - r\dot{\theta}^2 \cos \theta) \mathbf{i} + (\ddot{r} \sin \theta + 2\dot{r}\dot{\theta} \cos \theta + r\ddot{\theta} \cos \theta - r\dot{\theta}^2 \sin \theta) \mathbf{j} \\ &\quad + 2(-\omega_1 (\dot{r} \cos \theta - r\dot{\theta} \sin \theta) \mathbf{k}) \\ &\quad + (-\dot{\omega}_1 (L_1 + r \cos \theta) \mathbf{k} + (\dot{\omega}_1 L_2) \mathbf{i}) \\ &\quad + (-\omega_1^2 (L_1 + r \cos \theta) \mathbf{i} - \omega_1^2 L_2 \mathbf{k}) \end{aligned} \tag{6}$$

At snapshot time,  $\theta = 0$ , and the above simplifies to (noting that  $\dot{\theta} = \omega_2$  and  $\ddot{\theta} = \dot{\omega}_2$ )

$$\begin{aligned} \mathbf{a}_Q &= (\ddot{r} - r\omega_2^2) \mathbf{i} + (2\dot{r}\omega_2 + r\dot{\omega}_2) \mathbf{j} - 2\omega_1 \dot{r} \mathbf{k} - \dot{\omega}_1 (L_1 + r) \mathbf{k} + \dot{\omega}_1 L_2 \mathbf{i} - \omega_1^2 (L_1 + r) \mathbf{i} - \omega_1^2 L_2 \mathbf{k} \\ &= (\ddot{r} - r\omega_2^2 + \dot{\omega}_1 L_2 - \omega_1^2 (L_1 + r)) \mathbf{i} + (2\dot{r}\omega_2 + r\dot{\omega}_2) \mathbf{j} - (2\omega_1 \dot{r} + \dot{\omega}_1 (L_1 + r) + \omega_1^2 L_2) \mathbf{k} \end{aligned}$$

At the instance shown  $r = \frac{0.75}{2} = 0.375$  and  $\dot{r} = 1.5$  ft/sec,  $\ddot{r} = 0.8$  ft/sec<sup>2</sup>,  $L_1 = 2.5$ ,  $L_2 = 0.7$ ,  $L_3 = 1.4$ ,  $\omega_2 = 0.5$  rad/sec,  $\omega_1 = 1.2$  rad/sec,  $\dot{\omega}_2 = 0.25$  rad/sec<sup>2</sup>,  $\dot{\omega}_1 = 0.6$  rad/sec<sup>2</sup>, hence the above becomes

$$\begin{aligned} \mathbf{a}_Q &= (0.8 - 0.375(0.5^2) + 0.6(0.7) - 1.2^2(2.5 + 0.375)) \mathbf{i} \\ &\quad + (2(1.5)0.5 + (0.375)0.25) \mathbf{j} \\ &\quad - (2(1.2)1.5 + 0.6(2.5 + 0.375) + 1.2^2(0.7)) \mathbf{k} \end{aligned}$$

Therefore

$$\mathbf{a}_Q = -3.0138 \mathbf{i} + 1.5938 \mathbf{j} - 6.333 \mathbf{k} \tag{7}$$

Hence

$$\begin{aligned} |a_Q| &= \sqrt{3.0138^2 + 1.5938^2 + 6.333^2} \\ &= 7.1924 \text{ ft/sec}^2 \end{aligned}$$

### 4.3.2 problem 2

#### EMA 542 - Homework to Hand In

- 3B. A gyropendulum, consisting of a disk of radius  $R$ , rotates with a constant spin rate  $\dot{\psi}$  about the shaft  $BG$  of length  $L$ . The shaft is pivoted to another vertical shaft at  $B$  which rotates with the constant rate  $\dot{\phi}$ . The pivot, angle  $\theta$  changes at the constant rate  $\dot{\theta}$  as shown. The  $Z$  coordinate axis is fixed in space. The  $xyz$  coordinate system is attached to the shaft  $BG$ . The  $123$  coordinate system is attached to the disk. At the instant shown,  $123$  is aligned with  $xyz$ . Compute the total angular velocity and angular acceleration of the disk and express them in terms of the  $123$  body coordinates. Your solution should be in terms of  $\psi, \theta, \phi$  and their corresponding time derivatives.

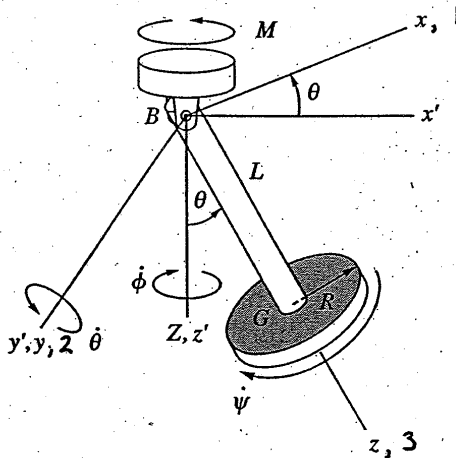

The total angular velocity  $\omega_G$  of the disk  $G$  using body coordinates  $\{e_1, e_2, e_3\}$  is

$$\begin{aligned} \omega_G &= \dot{\psi} e_3 + \dot{\theta} e_2 + \dot{\phi} \cos \theta e_3 \\ &= \dot{\theta} e_2 + (\dot{\phi} \cos \theta + \dot{\psi}) e_3 \end{aligned} \quad (1)$$

To find the acceleration, the rate of change of the above vector is taken. When taking rate

of change of each unit vector  $e$  the following will be used

$$\dot{e} = \vec{\omega}_e \times e$$

Where  $\omega_e$  is the angular rate that the unit vector  $e$  rotates relative to the inertial frame. Hence Eq. (1) becomes

$$\begin{aligned} \dot{\omega}_G &= \frac{d}{dt} (\dot{\theta} e_2) + \frac{d}{dt} (\dot{\phi} \cos \theta + \dot{\psi}) e_3 \\ &= \ddot{\theta} e_2 + \dot{\theta} (\omega_{e_2} \times e_2) + (\ddot{\phi} \cos \theta - \dot{\phi} \dot{\theta} \sin \theta + \ddot{\psi}) e_3 + (\dot{\phi} \cos \theta + \dot{\psi}) (\vec{\omega}_{e_3} \times e_3) \end{aligned} \quad (2)$$

What is left is to find  $\omega_{e_2} \times e_2$  and  $\omega_{e_3} \times e_3$ .

$$\begin{aligned} \omega_{e_2} \times e_2 &= (\dot{\theta} e_2 + (\dot{\phi} \cos \theta + \dot{\psi}) \vec{e}_3) \times e_2 \\ &= -(\dot{\phi} \cos \theta + \dot{\psi}) e_1 \end{aligned}$$

And

$$\begin{aligned} \omega_{e_3} \times e_3 &= (\dot{\theta} e_2 + (\dot{\phi} \cos \theta + \dot{\psi}) \vec{e}_3) \times e_3 \\ &= \dot{\theta} e_1 \end{aligned}$$

Hence Eq. (2) becomes

$$\begin{aligned} \dot{\omega}_G &= \ddot{\theta} e_2 + \dot{\theta} (-(\dot{\phi} \cos \theta + \dot{\psi}) e_1) + (\ddot{\phi} \cos \theta - \dot{\phi} \dot{\theta} \sin \theta + \ddot{\psi}) e_3 + (\dot{\phi} \cos \theta + \dot{\psi}) (\dot{\theta} e_1) \\ &= e_1 (-\dot{\theta} (\dot{\phi} \cos \theta + \dot{\psi}) + \dot{\theta} (\dot{\phi} \cos \theta + \dot{\psi})) + \ddot{\theta} e_2 + (\ddot{\phi} \cos \theta - \dot{\phi} \dot{\theta} \sin \theta + \ddot{\psi}) e_3 \\ &= \ddot{\theta} e_2 + (\ddot{\phi} \cos \theta - \dot{\phi} \dot{\theta} \sin \theta + \ddot{\psi}) e_3 \end{aligned}$$



4.3.3 key solution

EMA 542

Hwk.

(16)

A disk D of radius 0.75 ft spins with an angular speed  $\omega_2 = 0.5$  r/s with respect to the rigid but bent bar B. The angular speed  $\omega_2$  is increasing at a rate  $\dot{\omega}_2 = 0.25$  r/s<sup>2</sup>. Body B turns about a vertical axis through O at a rate  $\omega_1 = 1.2$  r/s which is increasing at a rate  $\dot{\omega}_1 = 0.6$  r/s<sup>2</sup>. A fly is moving on the surface of the disk D from point C to H, at a rate of 1.5 ft/sec which is increasing at a rate of 0.8 ft/sec<sup>2</sup>. Determine the absolute velocity and acceleration of the fly when the fly is at point Q.

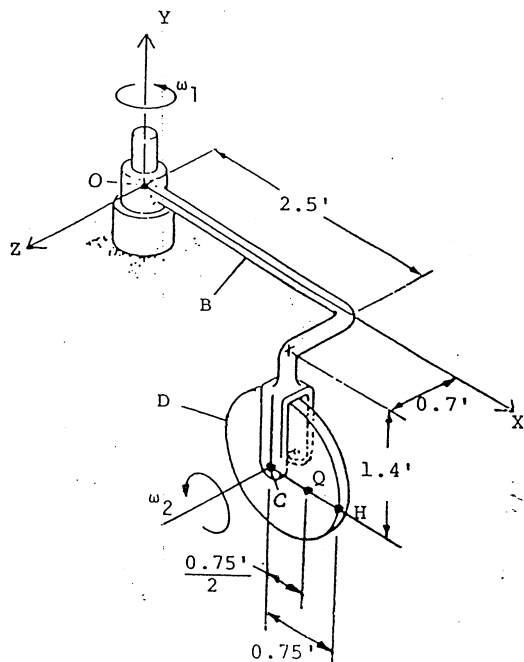

## SOLUTION TO PROBLEM 16

Velocity

$$\vec{v}_0 = \dot{\vec{R}} + \vec{\omega} \times \vec{\rho} + \dot{\vec{\rho}}_r \quad \vec{\omega} = \vec{\omega}_1$$

$$\text{where } \dot{\vec{R}} = \vec{v}_c = \vec{\omega}_1 \times \vec{r}_c$$

$$\therefore \dot{\vec{R}} = 1.2\vec{j} \times [0.5\vec{i} - 1.4\vec{j} + 1.7\vec{k}]$$

$$\Rightarrow \underline{\underline{\dot{\vec{R}}}} = .84\vec{i} - 3\vec{k}$$

$$\vec{\rho} = \frac{1}{3}(.75)\vec{i}$$

$$\dot{\vec{\rho}}_r = \dot{\rho}_r \vec{e}_\rho + \vec{\omega}_2 \times \vec{\rho}$$

$$\dot{\vec{\rho}}_r = 1.5\vec{i} + .5\vec{k} \times \frac{1}{3}(.75)\vec{i}$$

$$\therefore \underline{\underline{\dot{\vec{\rho}}_r}} = 1.5\vec{i} + .1875\vec{j}$$

$$\vec{\omega} \times \vec{\rho} = \vec{\omega}_1 \times \vec{\rho} = 1.2\vec{j} \times \frac{1}{3}(.75)\vec{i}$$

$$\therefore \underline{\underline{\vec{\omega} \times \vec{\rho}}} = -.45\vec{k}$$

$$\therefore \boxed{\vec{v}_0 = 2.34\vec{i} + .1875\vec{j} - 3.45\vec{k}}$$

- 2 -

ASSIGNATION

$$\vec{a}_c = \ddot{\vec{R}} + \vec{\omega} \times (\vec{\omega} \times \vec{r}) + \dot{\vec{\omega}} \times \vec{r} + \ddot{\vec{r}} + 2\vec{\omega} \times \dot{\vec{r}}$$

$$\ddot{\vec{R}} = \vec{a}_c = \dot{\vec{\omega}}_1 \times \vec{r}_c + \vec{\omega}_1 \times (\vec{\omega}_1 \times \vec{r}_c)$$

$$= .6\vec{j} \times [2.5\vec{i} - 1.4\vec{j} + .7\vec{k}] + (1.0\vec{j}) \times [.84\vec{i} - 3\vec{k}]$$

$$= -1.5\vec{k} + .42\vec{i} - 1.008\vec{k} - 3.6\vec{i}$$

$$\therefore \underline{\underline{\ddot{\vec{R}}}} = -3.18\vec{i} - 2.508\vec{k}$$

$$\vec{\omega} \times (\vec{\omega} \times \vec{r}) = \vec{\omega}_1 \times (\vec{\omega}_1 \times \vec{r}) = 1.0\vec{j} \times [-.45\vec{k}]$$

$$\therefore \underline{\underline{\vec{\omega} \times (\vec{\omega} \times \vec{r})}} = -.54\vec{i}$$

$$\dot{\vec{\omega}} \times \vec{r} = \dot{\vec{\omega}}_1 \times \vec{r} = .6\vec{j} \times \frac{1}{2}(.75)\vec{i}$$

$$\therefore \underline{\underline{\dot{\vec{\omega}} \times \vec{r}}} = -.225\vec{k}$$

$$\ddot{\vec{r}} = \ddot{\vec{\omega}}_2 \times (\vec{\omega}_2 \times \vec{r}) + \dot{\vec{\omega}}_2 \times \vec{r} + \ddot{\vec{r}}_{rr} + 2\vec{\omega}_2 \times \dot{\vec{r}}_{rr}$$

=

- 3 -

$$\begin{aligned} \ddot{\vec{r}} &= .5 \vec{k} \times (.1875 \vec{j}) + .25 \vec{k} \times \frac{1}{3} (.75) \vec{i} \\ &+ .8 \vec{i} + 2(.5) \vec{k} \times 1.5 \vec{i} \\ &= -.0938 \vec{i} + .0938 \vec{j} + .8 \vec{i} + 1.5 \vec{j} \end{aligned}$$

$$\therefore \underline{\underline{\ddot{\vec{r}}}} = .7062 \vec{i} + 1.5938 \vec{j}$$

$$2\vec{\omega} \times \dot{\vec{r}} = 2(1.0) \vec{j} \times [1.5 \vec{i} + .1875 \vec{j}]$$

$$\underline{\underline{2\vec{\omega} \times \dot{\vec{r}}}} = -3.6 \vec{k}$$

$$\therefore \vec{a}_a = [-3.18 \quad -.54 \quad +.7062] \vec{i}$$

$$+ [1.5938] \vec{j} + [-2.508 \quad -.225 \quad -3.6] \vec{k}$$

$$\therefore \boxed{\vec{a}_a = -3.0138 \vec{i} + 1.5938 \vec{j} - 6.333 \vec{k}}$$

EMA 542 - Homework to Hand In

- 3B. A gyropendulum, consisting of a disk of radius  $R$ , rotates with a constant spin rate  $\dot{\psi}$  about the shaft  $BG$  of length  $L$ . The shaft is pivoted to another vertical shaft at  $B$  which rotates with the constant rate  $\dot{\phi}$ . The pivot, angle  $\theta$  changes at the constant rate  $\dot{\theta}$  as shown. The  $Z$  coordinate axis is fixed in space. The  $xyz$  coordinate system is attached to the shaft  $BG$ . The  $123$  coordinate system is attached to the disk. At the instant shown,  $123$  is aligned with  $xyz$ . Compute the total angular velocity and angular acceleration of the disk and express them in terms of the  $123$  body coordinates. Your solution should be in terms of  $\psi, \theta, \phi$  and their corresponding time derivatives.

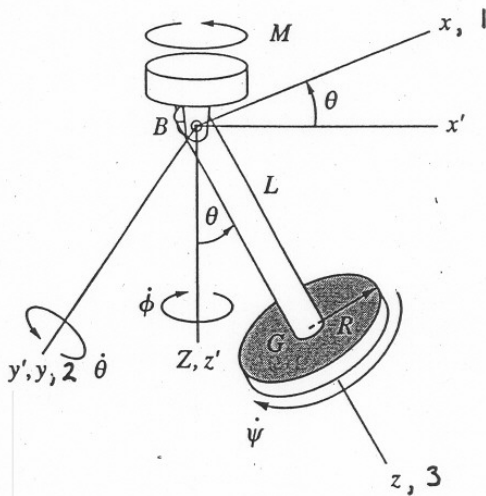

## SOLUTION TO 1

FIRST FORMULATI IN XYZ COORDINATES

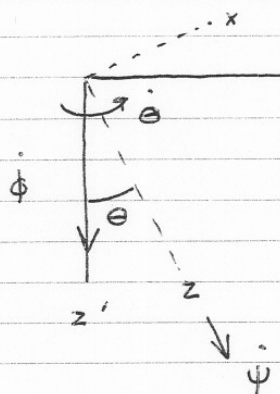

$$\vec{\omega} = \dot{\phi} \cos \theta \bar{i} - \dot{\phi} \sin \theta \bar{j} + \dot{\theta} \bar{j} + \dot{\psi} \bar{k}$$

$$\Rightarrow \vec{\omega} = -\dot{\phi} \sin \theta \bar{j} + \dot{\theta} \bar{j} + (\dot{\psi} + \dot{\phi} \cos \theta) \bar{k}$$

TRANSFORM TO BODY COORDS. 123:

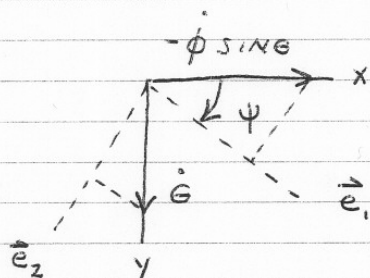

$$\Rightarrow \vec{\omega} = -\dot{\phi} \sin \theta \cos \psi \bar{e}_1 + \dot{\phi} \sin \theta \sin \psi \bar{e}_2 + \dot{\theta} \sin \psi \bar{e}_1 + \dot{\theta} \cos \psi \bar{e}_2 + (\dot{\psi} + \dot{\phi} \cos \theta) \bar{e}_3$$

$$\Rightarrow \vec{\omega} = (\dot{\theta} \sin \psi - \dot{\phi} \sin \theta \cos \psi) \bar{e}_1 + (\dot{\phi} \sin \theta \sin \psi + \dot{\theta} \cos \psi) \bar{e}_2 + (\dot{\psi} + \dot{\phi} \cos \theta) \bar{e}_3$$

- 2 -

ASSUME EULER ANGLES ARE CONSTANT

COMPUTE ANGULAR ACCELERATION AND EXPRESS  
IN BODY COORDINATES

TIME DERIVATIVE CAN BE COMPUTED IN INERTIAL  
COORDINATES OR BODY COORDINATES

TAKING TIME DERIVATIVE IN BODY COORDINATES

$$\begin{aligned} \Rightarrow \vec{\alpha} = \dot{\vec{\omega}} &= (\dot{\epsilon} \dot{\psi} \cos \psi - \dot{\phi} \dot{\epsilon} \cos \psi + \underbrace{\dot{\phi} \dot{\psi} \sin \psi}_{\cos \psi} \sin \psi) \vec{e}_1 \\ &+ (\dot{\phi} \dot{\epsilon} \cos \psi \sin \psi + \dot{\phi} \dot{\psi} \sin \psi \cos \psi - \dot{\epsilon} \dot{\psi} \sin \psi) \vec{e}_2 \\ &- \dot{\phi} \dot{\epsilon} \sin \psi \vec{e}_3 \end{aligned}$$

### 4.4 HW 3 different solution

#### 4.4.1 Problem 1

EMA 542

Hwk. (16)

A disk D of radius 0.75 ft spins with an angular speed  $\omega_2 = 0.5 \text{ r/s}$  with respect to the rigid but bent bar B. The angular speed  $\omega_2$  is increasing at a rate  $\dot{\omega}_2 = 0.25 \text{ r/s}^2$ . Body B turns about a vertical axis through O at a rate  $\omega_1 = 1.2 \text{ r/s}$  which is increasing at a rate  $\dot{\omega}_1 = 0.6 \text{ r/s}^2$ . A fly is moving on the surface of the disk D from point C to H, at a rate of 1.5 ft/sec which is increasing at a rate of  $0.8 \text{ ft/sec}^2$ . Determine the absolute velocity and acceleration of the fly when the fly is at point Q.

This problem is solved in two ways, using different body coordinates system, showing that the final answer is the same.



### 4.4.1.1 First case, body coordinates rotates with disk

Two coordinates systems are used. The first one has its origin at point  $O$  and rotates along with the long bar. This is the one shown above with  $xyz$  coordinates. The unit vectors for this coordinates system are  $\vec{e}_x, \vec{e}_y, \vec{e}_z$ . This coordinates system is rotating relative to inertial frame with angular velocity  $\omega_1 \vec{e}_y$ . The second coordinate system is centered at point  $C$  and rotates with the disk  $D$  (it can be imagined to be painted on disk  $D$  to make it more clear that it moves with the disk).

The second coordinates system (the one on the disk) will use unit vectors  $\vec{i}, \vec{j}, \vec{k}$ . It rotates with angular velocity  $\omega_2 \vec{k}$  relative to the first one. The following diagram illustrates this relation.

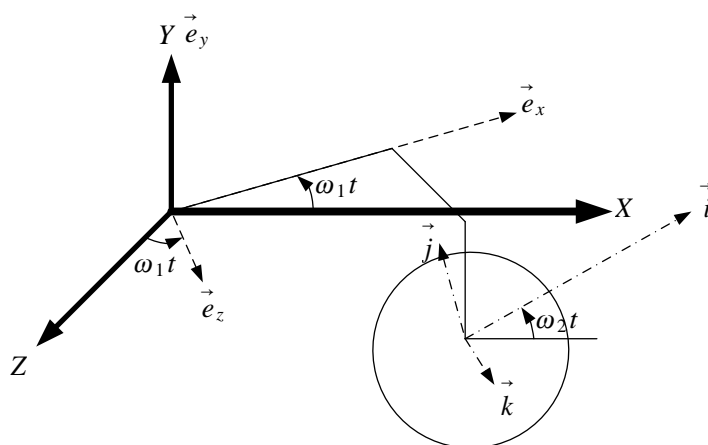

$\vec{k}$  and  $\vec{e}_z$  are always pointing the same direction for all time. But only at the snapshot shown in the problem diagram that  $\vec{e}_x = \vec{i}$  and  $\vec{e}_y = \vec{j}$ . So this problem will be solved at the snapshot time.

Given the above, a vector that represents the position of the center of the disk  $D$  relative to the first coordinate system is shown in this diagram



in straight line, since an observer standing on the disk is rotating with the same angular velocity as the ant as it moves away from the origin of the disk.

The position of  $Q$  as seen in inertial frame is therefore

$$\vec{r}_Q = \vec{R} + \vec{\rho} \quad (1)$$

Now  $\dot{\vec{r}} = \left(\frac{\dot{\vec{r}}}{r}\right)_r + (\vec{\omega} \times \vec{r})$  is applied to Eq.(1) above.

$$\dot{\vec{r}}_Q = \dot{\vec{R}}_r + (\vec{\omega}_1 \times \vec{R}) + \dot{\vec{\rho}}_r + ((\vec{\omega}_2 + \vec{\omega}_1) \times \vec{\rho}) \quad (2)$$

But  $\dot{\vec{R}}_r$  since it does not change in length. Hence

$$\dot{\vec{r}}_Q = (\vec{\omega}_1 \times \vec{R}) + \dot{\vec{\rho}}_r + ((\vec{\omega}_2 + \vec{\omega}_1) \times \vec{\rho}) \quad (2A)$$

and taking derivatives again gives

$$\begin{aligned} \ddot{\vec{r}}_Q &= \left( \dot{\vec{\omega}}_1 \times \vec{R} \right) + \left( \vec{\omega}_1 \times \left( \dot{\vec{R}}_r + (\vec{\omega}_1 \times \vec{R}) \right) \right) \\ &\quad + \ddot{\vec{\rho}}_r + (\vec{\omega}_2 + \vec{\omega}_1) \times \dot{\vec{\rho}}_r + (\dot{\vec{\omega}}_1 + \dot{\vec{\omega}}_2) \times \vec{\rho} \\ &\quad + (\vec{\omega}_2 + \vec{\omega}_1) \times \left( \dot{\vec{\rho}}_r + ((\vec{\omega}_2 + \vec{\omega}_1) \times \vec{\rho}) \right) \end{aligned}$$

In the above equation, since  $\vec{R}$  does not change in length, hence all its time derivatives are zero, and the above simplifies to

$$\begin{aligned} \ddot{\vec{r}}_Q &= \left( \dot{\vec{\omega}}_1 \times \vec{R} \right) + \left( \vec{\omega}_1 \times (\vec{\omega}_1 \times \vec{R}) \right) + \ddot{\vec{\rho}}_r \\ &\quad + (\vec{\omega}_2 + \vec{\omega}_1) \times \dot{\vec{\rho}}_r + (\dot{\vec{\omega}}_1 + \dot{\vec{\omega}}_2) \times \vec{\rho} \\ &\quad + (\vec{\omega}_2 + \vec{\omega}_1) \times \left( \dot{\vec{\rho}}_r + ((\vec{\omega}_2 + \vec{\omega}_1) \times \vec{\rho}) \right) \end{aligned}$$

Or

$$\begin{aligned} \ddot{\vec{r}}_Q &= \left( \dot{\vec{\omega}}_1 \times \vec{R} \right) + \left( \vec{\omega}_1 \times (\vec{\omega}_1 \times \vec{R}) \right) + \ddot{\vec{\rho}}_r \\ &\quad + \vec{\omega}_2 \times \dot{\vec{\rho}}_r + \vec{\omega}_1 \times \dot{\vec{\rho}}_r + \dot{\vec{\omega}}_1 \times \vec{\rho} + \dot{\vec{\omega}}_2 \times \vec{\rho} \\ &\quad + (\vec{\omega}_2 + \vec{\omega}_1) \times \left( \dot{\vec{\rho}}_r + (\vec{\omega}_2 \times \vec{\rho} + \vec{\omega}_1 \times \vec{\rho}) \right) \end{aligned} \quad (3A)$$

Eq. (2A) and (3A) above give the answers needed. The rest is just writing down each of the above vectors in component terms. Snapshot time is used as was described above.

#### 4.4.1.2 Finding the velocity of Q

At the snapshot time,

$$\vec{\omega}_1 = \omega_1 \vec{j}$$

and

$$\vec{\omega}_2 = \omega_2 \vec{k}$$

And

$$\vec{\rho} = \rho \vec{i}$$

The relative velocity of  $\vec{\rho}$  is given by

$$\dot{\vec{\rho}}_r = \dot{\rho} \vec{i}$$

And the relative acceleration of  $\vec{\rho}$  is given by

$$\ddot{\vec{\rho}}_r = \ddot{\rho} \vec{i}$$

and, at the snapshot time,

$$\vec{R} = L_1 \vec{i} + L_2 \vec{k} - L_3 \vec{j}$$

All terms in Eq. (2A) are now known. Hence

$$\begin{aligned} \dot{\vec{r}}_Q &= (\vec{\omega}_1 \times \vec{R}) + \dot{\vec{\rho}}_r + ((\vec{\omega}_2 + \vec{\omega}_1) \times \vec{\rho}) \\ &= (\omega_1 \vec{j}) \times (L_1 \vec{i} + L_2 \vec{k} - L_3 \vec{j}) + (\dot{\rho} \vec{i}) + ((\omega_2 \vec{k} + \omega_1 \vec{j}) \times \rho \vec{i}) \\ &= -\vec{k} (\omega_1 L_1) + \vec{i} (\omega_1 L_2) + \dot{\rho} \vec{i} + \vec{j} \omega_2 \rho - \omega_1 \rho \vec{k} \\ &= (\omega_1 L_2 + \dot{\rho}) \vec{i} + \omega_2 \rho \vec{j} - \omega_1 (L_1 + \rho) \vec{k} \end{aligned} \quad (4)$$

At the instance shown  $\rho = \frac{0.75}{2} = 0.375$  and  $\dot{\rho}(t) = 1.5$  ft/sec,  $L_1 = 2.5$ ,  $L_2 = 0.7$ ,  $L_3 = 1.4$ ,  $\omega_2 = 0.5$  rad/sec,  $\omega_1 = 1.2$  rad/sec, hence Eq. (3) becomes

$$\begin{aligned} \dot{\vec{r}}_Q &= ((1.2)(0.7) + 1.5) \vec{i} + (0.5)(0.375) \vec{j} - (1.2)(2.5 + 0.375) \vec{k} \\ &= 2.34 \vec{i} + 0.1875 \vec{j} - 3.45 \vec{k} \end{aligned}$$

Therefore

$$\begin{aligned} \left| \dot{\vec{r}}_Q \right| &= \sqrt{2.34^2 + 0.1875^2 + 3.45^2} \\ &= 4.1729 \quad ft/sec \end{aligned}$$

#### 4.4.1.3 Finding the acceleration of Q

From Eq.(3A) becomes

$$\begin{aligned} \ddot{\vec{r}}_Q &= \left( \dot{\vec{\omega}}_1 \times \vec{R} \right) + \left( \vec{\omega}_1 \times \left( \vec{\omega}_1 \times \vec{R} \right) \right) + \ddot{\vec{\rho}}_r \quad (3A) \\ &+ \vec{\omega}_2 \times \dot{\vec{\rho}}_r + \vec{\omega}_1 \times \dot{\vec{\rho}}_r + \dot{\vec{\omega}}_1 \times \vec{\rho} + \dot{\vec{\omega}}_2 \times \vec{\rho} \\ &+ \left( \vec{\omega}_2 + \vec{\omega}_1 \right) \times \left( \dot{\vec{\rho}}_r + \left( \vec{\omega}_2 \times \vec{\rho} + \vec{\omega}_1 \times \vec{\rho} \right) \right) \end{aligned}$$

Hence

$$\begin{aligned} \ddot{\vec{r}}_Q &= \left( \dot{\omega}_1 \vec{j} \times \left( L_1 \vec{i} + L_2 \vec{k} - L_3 \vec{j} \right) \right) + \left( \omega_1 \vec{j} \times \left( \omega_1 \vec{j} \times \left( L_1 \vec{i} + L_2 \vec{k} - L_3 \vec{j} \right) \right) \right) \\ &+ \ddot{\rho} \vec{i} \\ &+ \left( \omega_2 \vec{k} \times \dot{\rho} \vec{i} \right) \\ &+ \left( \omega_1 \vec{j} \times \dot{\rho} \vec{i} \right) \\ &+ \left( \dot{\omega}_1 \vec{j} \times \rho \vec{i} \right) \\ &+ \left( \dot{\omega}_2 \vec{k} \times \rho \vec{i} \right) \\ &+ \left( \omega_2 \vec{k} + \omega_1 \vec{j} \right) \times \left( \dot{\rho} \vec{i} + \left( \omega_2 \vec{k} \times \rho \vec{i} + \omega_1 \vec{j} \times \rho \vec{i} \right) \right) \end{aligned}$$

Hence

$$\begin{aligned}\ddot{\vec{r}}_Q &= -\dot{\omega}_1 L_1 \vec{k} + \dot{\omega}_1 L_2 \vec{i} - \omega_1^2 L_1 \vec{i} - \omega_1^2 L_2 \vec{k} \\ &\quad + \ddot{\rho}(t) \vec{i} \\ &\quad + \omega_2 \dot{\rho}(t) \vec{j} \\ &\quad - \omega_1 \dot{\rho} \vec{k} \\ &\quad + \dot{\omega}_1 \rho \vec{k} \\ &\quad + \dot{\omega}_2 \rho \vec{j} \\ &\quad + (\omega_2 \vec{k} + \omega_1 \vec{j}) \times (\dot{\rho} \vec{i} + \omega_2 \rho \vec{j} - \omega_1 \rho \vec{k})\end{aligned}$$

Or

$$\begin{aligned}\ddot{\vec{r}}_Q &= -\dot{\omega}_1 L_1 \vec{k} + \dot{\omega}_1 L_2 \vec{i} - \omega_1^2 L_1 \vec{i} - \omega_1^2 L_2 \vec{k} \\ &\quad + \ddot{\rho}(t) \vec{i} \\ &\quad + \omega_2 \dot{\rho}(t) \vec{j} \\ &\quad - \omega_1 \dot{\rho} \vec{k} \\ &\quad + \dot{\omega}_1 \rho \vec{k} \\ &\quad + \dot{\omega}_2 \rho \vec{j} \\ &\quad + (\omega_2 \dot{\rho} \vec{j} - \omega_2^2 \rho \vec{i}) + (-\omega_1 \dot{\rho} \vec{k} - \omega_1^2 \rho \vec{i})\end{aligned}$$

Collecting terms

$$\ddot{\vec{r}}_Q = \vec{i} \left( \dot{\omega}_1 L_2 - \omega_1^2 (L_1 + \rho) - \omega_2^2 \rho + \ddot{\rho} \right) + \vec{j} \left( 2\omega_2 \dot{\rho} + \dot{\omega}_2 \rho \right) - \vec{k} \left( \omega_1^2 L_2 + \dot{\omega}_1 (L_1 + \rho) + 2\omega_1 \dot{\rho} \right) \quad (5)$$

At the instance shown  $\rho(t) = \frac{0.75}{2} = 0.375$  and  $\dot{\rho}(t) = 1.5$  ft/sec,  $\ddot{\rho}(t) = 0.8$  ft/sec<sup>2</sup>,  $L_1 = 2.5$ ,  $L_2 = 0.7$ ,  $L_3 = 1.4$ ,  $\omega_2 = 0.5$  rad/sec,  $\omega_1 = 1.2$  rad/sec,  $\dot{\omega}_2 = 0.25$  rad/sec<sup>2</sup>,  $\dot{\omega}_1 = 0.6$  rad/sec<sup>2</sup>, hence the above becomes

$$\begin{aligned}\ddot{\vec{r}}_Q &= \vec{i} \left( (0.6) 0.7 - (1.2)^2 (2.5 + 0.375) - 0.5^2 (0.375) + 0.8 \right) \\ &\quad + \vec{j} \left( 2(0.5) 1.5 + (0.25) 0.375 \right) \\ &\quad - \vec{k} \left( 1.2^2 (0.7) + 0.6 (2.5 + 0.375) + 2(1.2) 1.5 \right)\end{aligned}$$

Therefore

$$\ddot{\vec{r}}_Q = -3.0138 \vec{i} + 1.5938 \vec{j} - 6.333 \vec{k}$$

Therefore

$$\begin{aligned} \left| \ddot{\vec{r}}_Q \right| &= \sqrt{3.0138^2 + 1.5938^2 + 6.333^2} \\ &= 7.1924 \text{ ft/sec}^2 \end{aligned}$$

#### 4.4.1.4 Second case, body coordinates attached to holding bar

In this case, the local body coordinates  $\vec{i}, \vec{j}, \vec{k}$  is attached to the bar labeled  $L_3$  and hence does not rotate with the disk, as shown in this diagram

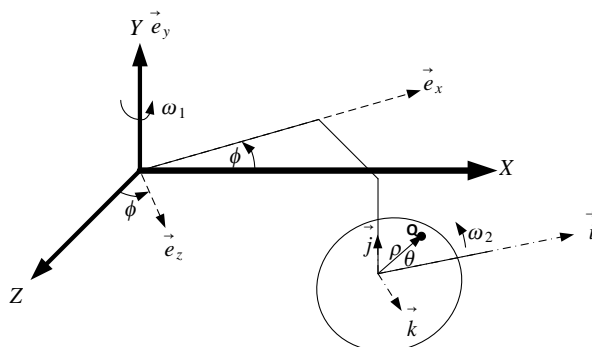

The main difference between this set up and the first case, is that now  $\vec{k}$  and  $\vec{e}_z$  are still pointing the same direction for all time but now also  $\vec{e}_x$  and  $\vec{i}$  are always pointing in same direction, as well as  $\vec{e}_y$  and  $\vec{j}$ . And now body frame  $\vec{i}, \vec{j}, \vec{k}$  does not rotate relative to frame  $\vec{e}_x, \vec{e}_y, \vec{e}_z$ . The two frames are actually fixed to each others, and only difference is that the origin of one is displaced from the other by the vector  $\vec{R}$ .

Using the same equations (2A) and (3A), the only difference is in writing down the components of the vectors.

$$\dot{\vec{r}}_Q = (\vec{\omega}_1 \times \vec{R}) + \dot{\vec{\rho}}_r + \overbrace{(\vec{\omega}_2 \times \vec{\rho})}^{\text{This term is zero now}} \quad (2A)$$

$$\ddot{\vec{r}}_Q = \left( \dot{\vec{\omega}}_1 \times \vec{R} \right) + \left( \vec{\omega}_1 \times \vec{\omega}_1 \times \vec{R} \right) + \ddot{\vec{\rho}}_r + \overbrace{2 \left( \vec{\omega}_2 \times \dot{\vec{\rho}}_r \right) + \left( \dot{\vec{\omega}}_2 \times \vec{\rho} \right) + \vec{\omega}_2 \times \vec{\omega}_2 \times \vec{\rho}}^{\text{This term is zero in this case}} \quad (3A)$$

Since now frame  $\vec{i}, \vec{j}, \vec{k}$  does not rotate relative to the frame  $\vec{e}_x, \vec{e}_y, \vec{e}_z$ , then the above simplifies to

$$\dot{\vec{r}}_Q = (\vec{\omega}_1 \times \vec{R}) + \dot{\vec{\rho}}_r \quad (2AA)$$

$$\ddot{\vec{r}}_Q = \left( \dot{\vec{\omega}}_1 \times \vec{R} \right) + \left( \vec{\omega}_1 \times \vec{\omega}_1 \times \vec{R} \right) + \ddot{\vec{\rho}}_r \quad (3AA)$$

Now the vector  $\vec{\rho}$  is

$$\vec{\rho} = (\rho \cos \theta) \vec{i} + (\rho \sin \theta) \vec{j} + 0\vec{k}$$

The relative velocity of  $\vec{\rho}$  is now given by

$$\dot{\vec{\rho}}_r = (\dot{\rho} \cos \theta - \rho \dot{\theta} \sin \theta) \vec{i} + (\dot{\rho} \sin \theta + \rho \dot{\theta} \cos \theta) \vec{j} + 0\vec{k}$$

And the relative acceleration of  $\vec{\rho}$  is given by

$$\begin{aligned} \ddot{\vec{\rho}}_r &= \left( (\ddot{\rho} \cos \theta - \dot{\rho} \dot{\theta} \sin \theta) - (\dot{\rho} \dot{\theta} \sin \theta + \rho \ddot{\theta} \sin \theta + \rho \dot{\theta}^2 \cos \theta) \right) \vec{i} \\ &+ \left( (\ddot{\rho} \sin \theta + \dot{\rho} \dot{\theta} \cos \theta) + (\dot{\rho} \dot{\theta} \cos \theta + \rho \ddot{\theta} \cos \theta - \rho \dot{\theta}^2 \sin \theta) \right) \vec{j} \\ &+ 0\vec{k} \end{aligned}$$

All remaining vectors are the same as the first case. In particular

$$\vec{R} = L_1 \vec{i} + L_2 \vec{k} - L_3 \vec{j}$$

However, this vector is now valid for all time, and not only at the snapshot. Hence Eq. (2AA) now can be written down as

$$\begin{aligned} \dot{\vec{r}}_Q &= (\omega_1 \vec{j}) \times (L_1 \vec{i} + L_2 \vec{k} - L_3 \vec{j}) + (\dot{\rho} \cos \theta - \rho \dot{\theta} \sin \theta) \vec{i} + (\dot{\rho} \sin \theta + \rho \dot{\theta} \cos \theta) \vec{j} \\ &= -\vec{k} (\omega_1 L_1) + \vec{i} (\omega_1 L_2) + (\dot{\rho} \cos \theta - \rho \dot{\theta} \sin \theta) \vec{i} + (\dot{\rho} \sin \theta + \rho \dot{\theta} \cos \theta) \vec{j} \\ &= (\omega_1 L_2 + \dot{\rho} \cos \theta - \rho \dot{\theta} \sin \theta) \vec{i} + (\dot{\rho} \sin \theta + \rho \dot{\theta} \cos \theta) \vec{j} - \omega_1 L_1 \vec{k} \end{aligned}$$

Since  $\dot{\theta} = \omega_2$  then

$$\dot{\vec{r}}_Q = (\omega_1 L_2 + \dot{\rho} \cos \theta - \rho \omega_2 \sin \theta) \vec{i} + (\dot{\rho} \sin \theta + \rho \omega_2 \cos \theta) \vec{j} - \omega_1 L_1 \vec{k} \quad (6)$$

Now, at the snapshot time,  $\theta = 0^0$ , hence the above simplifies to

$$\dot{\vec{r}}_Q = (\omega_1 L_2 + \dot{\rho}) \vec{i} + \omega_2 \rho \vec{j} - \omega_1 L_1 \vec{k} \quad (6A)$$

Comparing the above Eq. (6A) to Eq. (4) found in the first case, it is seen to be the same, as expected. The difference is that Eq. (6) is valid for all time, while Eq. (4) is valid at the



snapshot only. Now the acceleration will be found from Eq. (3AA)

$$\begin{aligned}\ddot{\vec{r}}_Q &= \left( \dot{\omega}_1 \vec{j} \times \left( L_1 \vec{i} + L_2 \vec{k} - L_3 \vec{j} \right) \right) + \left( \omega_1 \vec{j} \times \left( \omega_1 \vec{j} \times \left( L_1 \vec{i} + L_2 \vec{k} - L_3 \vec{j} \right) \right) \right) \\ &+ \left( \left( \ddot{\rho} \cos \theta - \dot{\rho} \dot{\theta} \sin \theta \right) - \left( \dot{\rho} \dot{\theta} \sin \theta + \rho \ddot{\theta} \sin \theta + \rho \dot{\theta}^2 \cos \theta \right) \right) \vec{i} \\ &+ \left( \left( \ddot{\rho} \sin \theta + \dot{\rho} \dot{\theta} \cos \theta \right) + \left( \dot{\rho} \dot{\theta} \cos \theta + \rho \ddot{\theta} \cos \theta - \rho \dot{\theta}^2 \sin \theta \right) \right) \vec{j}\end{aligned}$$

Hence

$$\begin{aligned}\ddot{\vec{r}}_Q &= -\dot{\omega}_1 L_1 \vec{k} + \dot{\omega}_1 L_2 \vec{i} - \omega_1 \omega_1 L_1 \vec{i} - \omega_1 \omega_1 L_2 \vec{k} \\ &+ \left( \left( \ddot{\rho} \cos \theta - \dot{\rho} \dot{\theta} \sin \theta \right) - \left( \dot{\rho} \dot{\theta} \sin \theta + \rho \ddot{\theta} \sin \theta + \rho \dot{\theta}^2 \cos \theta \right) \right) \vec{i} \\ &+ \left( \left( \ddot{\rho} \sin \theta + \dot{\rho} \dot{\theta} \cos \theta \right) + \left( \dot{\rho} \dot{\theta} \cos \theta + \rho \ddot{\theta} \cos \theta - \rho \dot{\theta}^2 \sin \theta \right) \right) \vec{j}\end{aligned}$$

But  $\dot{\theta} = \omega_2$  and  $\dot{\theta}^2 = \omega_2^2$  and  $\ddot{\theta} = \dot{\omega}_2$  hence the above becomes

$$\begin{aligned}\ddot{\vec{r}}_Q &= -\dot{\omega}_1 L_1 \vec{k} + \dot{\omega}_1 L_2 \vec{i} - \omega_1 \omega_1 L_1 \vec{i} - \omega_1 \omega_1 L_2 \vec{k} \\ &+ \left( \left( \ddot{\rho} \cos \theta - \dot{\rho} \omega_2 \sin \theta \right) - \left( \dot{\rho} \omega_2 \sin \theta + \rho \dot{\omega}_2 \sin \theta + \rho \omega_2^2 \cos \theta \right) \right) \vec{i} \\ &+ \left( \left( \ddot{\rho} \sin \theta + \dot{\rho} \omega_2 \cos \theta \right) + \left( \dot{\rho} \omega_2 \cos \theta + \rho \dot{\omega}_2 \cos \theta - \rho \omega_2^2 \sin \theta \right) \right) \vec{j}\end{aligned}$$

Collecting terms

$$\begin{aligned}\ddot{\vec{r}}_Q &= \vec{i} \left( \dot{\omega}_1 L_2 - \omega_1^2 L_1 + \ddot{\rho} \cos \theta - 2\dot{\rho} \omega_2 \sin \theta - \rho \dot{\omega}_2 \sin \theta - \rho \omega_2^2 \cos \theta \right) \\ &+ \vec{j} \left( \ddot{\rho} \sin \theta + 2\dot{\rho} \omega_2 \cos \theta + \rho \dot{\omega}_2 \cos \theta - \rho \omega_2^2 \sin \theta \right) \\ &+ \vec{k} \left( -\dot{\omega}_1 L_1 - \omega_1^2 L_2 \right)\end{aligned}\tag{7}$$

Now, at snapshot, where  $\theta = 0^0$ , the above simplifies to

$$\ddot{\vec{r}}_Q = \vec{i} \left( \dot{\omega}_1 L_2 - \omega_1^2 L_1 + \ddot{\rho} - \rho \omega_2^2 \right) + \vec{j} \left( 2\dot{\rho} \omega_2 + \rho \dot{\omega}_2 \right) + \vec{k} \left( -\dot{\omega}_1 L_1 - \omega_1^2 L_2 \right)\tag{7A}$$

Comparing the Eq. (7A) above to Eq. (5) found in the first case, it is seen they are the same. The difference is that Eq. (7) now can be used for all time, while Eq. (5) was valid only at the snapshot.

## 4.5 HW 4

## 4.5.1 Problem 1

## EMA 542

## Home Work to be Handed In

- 4) The pendulum shown in the figure consists of two rods.  $AB$  is pin-supported at  $A$  and swings only in the  $Y-Z$  plane, whereas a bearing at  $B$  allows the attached rod  $BD$  to spin about rod  $AB$ . At a given instant, the rods have the angular motions shown. If a collar  $C$  is located  $0.2$  m from  $B$ , has a velocity of  $3.0$  m/s and an acceleration of  $2.0$  m/s<sup>2</sup> along the rod, determine the velocity and acceleration of the collar at this instant.

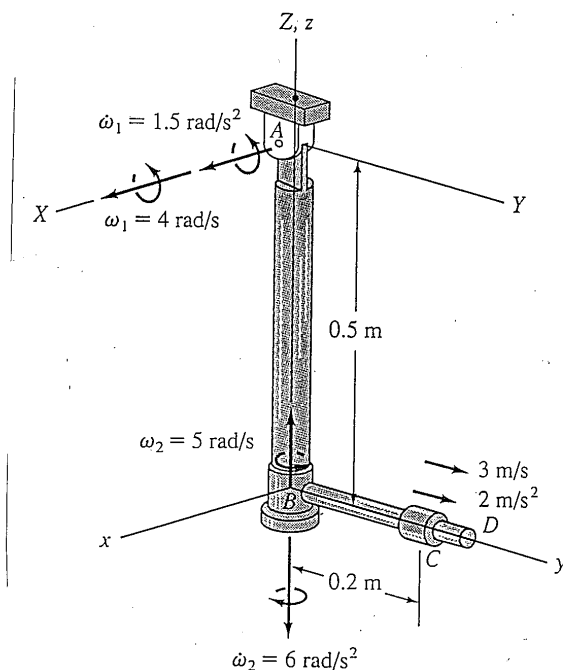

The first step is to decide where to put the origin of the rotating coordinates system, and the second step is to decide to where to attach it to.

Lets put the origin at point  $B$  and have the frame attached to the bar  $BD$  as well. This way the relative velocity and acceleration will be simple, but the angular acceleration will be more involved.

Therefore, this diagram shows a general configuration to help understand the set up

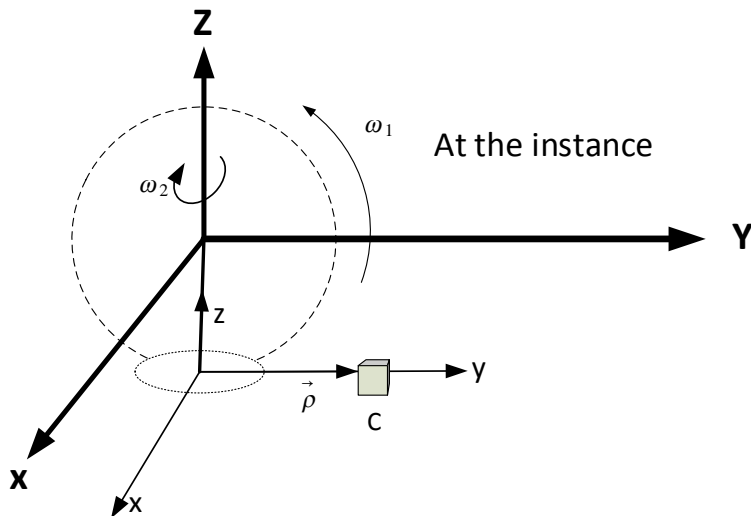
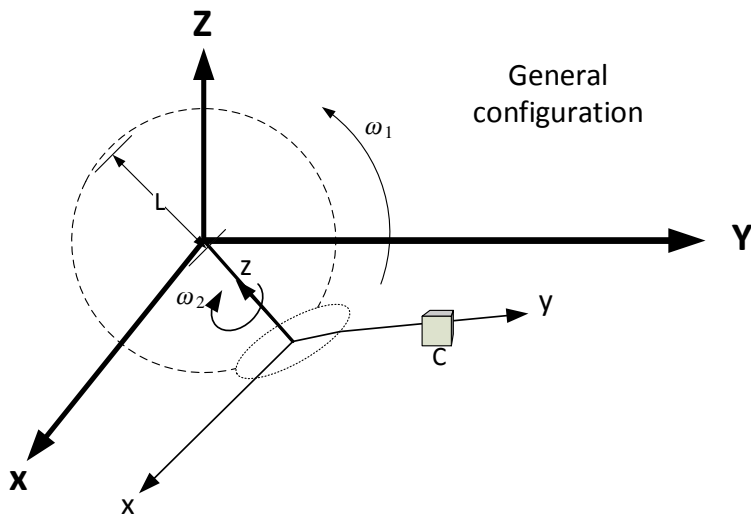

Let units vectors for rotating coordinates system be  $\vec{i}, \vec{j}, \vec{k}$  and for the fixed coordinates system be  $\vec{I}, \vec{J}, \vec{K}$ .

From the above, Let  $L$  be the length of Bar AB. Hence

$$\begin{aligned} \vec{\rho} &= \rho \vec{j} \\ \dot{\vec{\rho}}_r &= \dot{\rho} \vec{j} \\ \dot{\vec{R}} &= L\omega_1 \vec{j} \quad \text{at snapshot only} \\ \vec{\omega} &= \omega_1 \vec{I} + \omega_2 \vec{k} \end{aligned}$$

Hence

$$\begin{aligned}\vec{V} &= \dot{\vec{R}} + \dot{\vec{\rho}}_r + \vec{\omega} \times \vec{\rho} \\ &= L\omega_1 \vec{j} + \dot{\rho} \vec{j} + (\omega_1 \vec{I} + \omega_2 \vec{k}) \times \rho \vec{j}\end{aligned}\quad (1)$$

But at snapshot,  $\vec{I} = \vec{i}$ , hence

$$\begin{aligned}\vec{V} &= L\omega_1 \vec{j} + \dot{\rho} \vec{j} + \omega_1 \rho \vec{k} - \omega_2 \rho \vec{i} \\ &= -\omega_2 \rho \vec{i} + (L\omega_1 + \dot{\rho}) \vec{j} + \omega_1 \rho \vec{k}\end{aligned}$$

At snapshot,  $\omega_2 = 5\text{rad/sec}$ ,  $\omega_1 = 4\text{rad/sec}$ ,  $L = 0.5\text{m}$ ,  $\dot{\rho} = 3\text{m/s}$ ,  $\rho = 0.2\text{m}$ , hence

$$\begin{aligned}\vec{V} &= -5(0.2) \vec{i} + (0.5(4) + 3) \vec{j} + 4(0.2) \vec{k} \\ &= -1 \vec{i} + 5 \vec{j} + 0.8 \vec{k}\end{aligned}\quad (2)$$

Hence

$$|\vec{V}| = \sqrt{1^2 + 5^2 + 0.8^2} = 5.1614 \quad \text{m/sec}$$

Now to find the acceleration

$$\begin{aligned}\vec{a} &= \ddot{\vec{R}} + \ddot{\vec{\rho}}_r + \vec{\omega} \times \dot{\vec{\rho}}_r + \dot{\vec{\omega}} \times \vec{\rho} + \vec{\omega} \times (\dot{\vec{\rho}}_r + \vec{\omega} \times \vec{\rho}) \\ &= \ddot{\vec{R}} + \ddot{\vec{\rho}}_r + \vec{\omega} \times \dot{\vec{\rho}}_r + \dot{\vec{\omega}} \times \vec{\rho} + \vec{\omega} \times \dot{\vec{\rho}}_r + (\vec{\omega} \times (\vec{\omega} \times \vec{\rho})) \\ &= \ddot{\vec{R}} + \ddot{\vec{\rho}}_r + 2\vec{\omega} \times \dot{\vec{\rho}}_r + \dot{\vec{\omega}} \times \vec{\rho} + (\vec{\omega} \times (\vec{\omega} \times \vec{\rho}))\end{aligned}\quad (3)$$

Now each term is found.

$$\begin{aligned}\ddot{\vec{R}} &= L\dot{\omega}_1 \vec{j} + L\omega_1^2 \vec{k} = 0.5(1.5) \vec{j} + 0.5(4^2) \vec{k} = 0.75 \vec{j} + 8 \vec{k} \\ \ddot{\vec{\rho}}_r &= \ddot{\rho} \vec{j}\end{aligned}$$

$$\dot{\vec{\omega}} = \dot{\omega}_1 \vec{I} - \overbrace{\left( \dot{\omega}_2 \vec{k} + (\omega_1 \vec{i} \times \omega_2 \vec{k}) \right)}^{\frac{d}{dt}(\omega_2 \vec{k})}$$

$$\dot{\vec{\omega}} = \dot{\omega}_1 \vec{I} - \dot{\omega}_2 \vec{k} + \omega_1 \omega_2 \vec{j}$$

But at snapshot  $\vec{I} = \vec{i}$ , hence

$$\dot{\vec{\omega}} = \dot{\omega}_1 \vec{i} - \dot{\omega}_2 \vec{k} + \omega_1 \omega_2 \vec{j}$$

Now all the terms have been found, then Eq. (3) becomes (valid at snapshot only)

$$\begin{aligned}\vec{a} &= \left(L\dot{\omega}_1\vec{j} + L\omega_1^2\vec{k}\right) + \ddot{\rho}\vec{j} \\ &+ 2\left(\omega_1\vec{i} + \omega_2\vec{k}\right) \times \dot{\rho}\vec{j} \\ &+ \left(\dot{\omega}_1\vec{i} - \dot{\omega}_2\vec{k} + \omega_1\omega_2\vec{j}\right) \times \rho\vec{j} \\ &+ \left(\left(\omega_1\vec{i} + \omega_2\vec{k}\right) \times \left(\left(\omega_1\vec{i} + \omega_2\vec{k}\right) \times \rho\vec{j}\right)\right)\end{aligned}$$

Hence

$$\begin{aligned}\vec{a} &= \left(L\dot{\omega}_1\vec{j} + L\omega_1^2\vec{k}\right) + \ddot{\rho}\vec{j} \\ &+ 2\left(\omega_1\dot{\rho}\vec{k} - \omega_2\dot{\rho}\vec{i}\right) \\ &+ \left(\dot{\omega}_1\rho\vec{k} + \dot{\omega}_2\rho\vec{i}\right) \\ &+ \left(\left(\omega_1\vec{i} + \omega_2\vec{k}\right) \times \left(\omega_1\rho\vec{k} - \omega_2\rho\vec{i}\right)\right)\end{aligned}$$

Therefore

$$\vec{a} = \left(L\dot{\omega}_1\vec{j} + L\omega_1^2\vec{k}\right) + \ddot{\rho}\vec{j} + 2\left(\omega_1\dot{\rho}\vec{k} - \omega_2\dot{\rho}\vec{i}\right) + \left(\dot{\omega}_1\rho\vec{k} + \dot{\omega}_2\rho\vec{i}\right) + \left(-\omega_1\omega_1\rho\vec{j} - \omega_2\omega_2\rho\vec{j}\right)$$

Collecting terms

$$\vec{a} = \left(-2\omega_2\dot{\rho} + \dot{\omega}_2\rho\right)\vec{i} + \left(L\dot{\omega}_1 + \ddot{\rho} - \omega_1^2\rho - \omega_2^2\rho\right)\vec{j} + \left(L\omega_1^2 + 2\omega_1\dot{\rho} + \dot{\omega}_1\rho\right)\vec{k}$$

At snapshot,  $\omega_2 = 5\text{rad/sec}$ ,  $\omega_1 = 4\text{rad/sec}$ ,  $L = 0.5\text{m}$ ,  $\dot{\rho} = 3\text{m/s}$ ,  $\rho = 0.2\text{m}$ ,  $\ddot{\rho} = 2\text{m/s}$ ,  $\dot{\omega}_1 = 1.5\text{rad/sec}^2$ ,  $\dot{\omega}_2 = 6\text{m/sec}^2$ , hence

$$\begin{aligned}\vec{a} &= \left(-2(5)(3) + 6(0.2)\right)\vec{i} + \left(0.5(1.5) + 2 - 4^2(0.2) - 5^2(0.2)\right)\vec{j} + \left(0.5(4^2) + 2(4)3 + 1.5(0.2)\right)\vec{k} \\ &= -28.8\vec{i} - 5.45\vec{j} + 32.3\vec{k}\end{aligned}$$

Hence

$$|\vec{a}| = \sqrt{28.8^2 + 5.45^2 + 32.3^2} = 43.617\text{m/s}^2$$

## 4.5.2 Problem 2

EM 542

4B

The mass center  $G$  of an airplane has its velocity vector given as a function of time electronically as  $\vec{v}_G = 200\vec{j} + 3t\vec{k}$  (ft/s) where the body axes  $\vec{i}, \vec{j}, \vec{k}$  are shown. Also rate gyros indicate that its pitch rate  $\dot{\alpha}$  is constant at  $\dot{\alpha} = 0.1$  rad/s, its roll rate  $\dot{\beta}$  is constant at  $\dot{\beta} = 0.2$  rad/s and its yaw rate  $\dot{\gamma}$  remains zero. Fluid is flowing along the hydraulic line  $G, A, B, C$  shown, where the portion  $A, B, C$  is a circular path of radius 5 ft in the  $yz$  body plane. The speed of all fluid particles relative to the hydraulic line is given by  $\dot{s} = 70 - 5t$  (ft/s). Determine at the time  $t = 10$  seconds:

- (a) the inertial velocity  $\vec{v}_p$  of the fluid particle instantaneously at  $B$ , and  
 (b) its inertial acceleration  $\vec{a}_p$ .

Note: Give all answers in terms of components along the rotating body axes  $\vec{i}, \vec{j}, \vec{k}$ . Please report all terms because they will be graded individually.

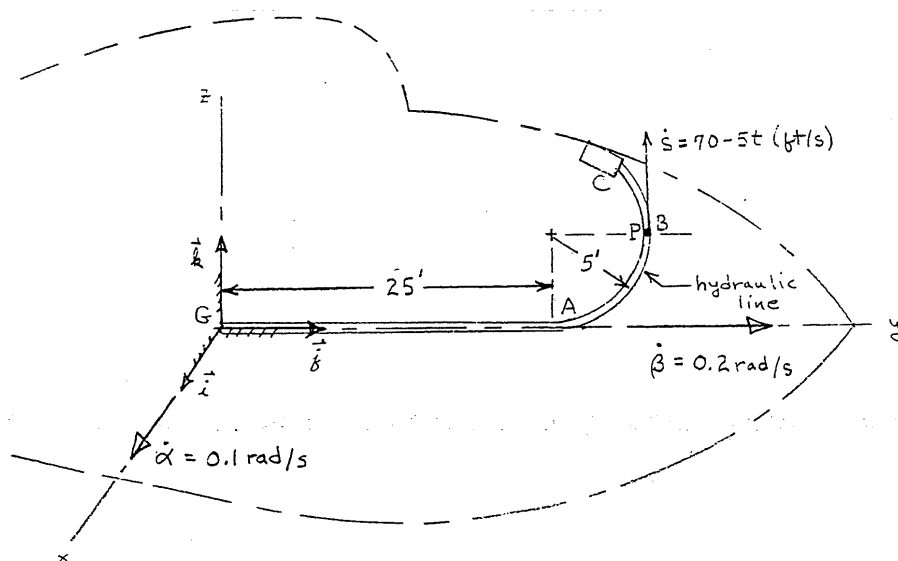

Let the origin of the rotating frame be  $G$  as shown. Let  $L$  be the length given by  $25'$ , and let  $r$  be the radius of the hydraulic line. Hence, for the fluid particle at  $B$

$$\vec{\rho} = (L + r)\vec{j} + r\vec{k}$$

$$\dot{\vec{\rho}}_r = \dot{s}\vec{k}$$

$$\vec{R} = 200\vec{j} + 3t\vec{k}$$

$$\vec{\omega} = \dot{\alpha}\vec{i} + \dot{\beta}\vec{j}$$

Hence

$$\begin{aligned}
 \vec{V} &= \vec{R} + \dot{\vec{\rho}}_r + \vec{\omega} \times \vec{\rho} \\
 &= (200\vec{j} + 3t\vec{k}) + (\dot{s}\vec{k}) + (\dot{\alpha}\vec{i} + \dot{\beta}\vec{j}) \times ((L+r)\vec{j} + r\vec{k}) \\
 &= (200\vec{j} + 3t\vec{k}) + (\dot{s}\vec{k}) + \dot{\alpha}(L+r)\vec{k} - \dot{\alpha}r\vec{j} + \dot{\beta}r\vec{i} \\
 &= \vec{i}(\dot{\beta}r) + \vec{j}(200 - \dot{\alpha}r) + \vec{k}(3t + \dot{s} + \dot{\alpha}(L+r))
 \end{aligned} \tag{1}$$

At snapshot,  $t = 10 \text{ sec}$ ,  $r = 5'$ ,  $L = 25'$ ,  $\dot{\beta} = 0.2 \text{ rad/sec}$ ,  $\dot{\alpha} = 0.1 \text{ rad/sec}$ ,  $\dot{s} = 70 - 5t$ , hence the above becomes

$$\begin{aligned}
 \vec{V} &= \vec{i}(0.2(5)) + \vec{j}(200 - 0.1(5)) + \vec{k}(3(10) + (70 - 50) + 0.1(25 + 5)) \\
 &= \vec{i} + 199.5\vec{j} + 53\vec{k}
 \end{aligned}$$

Hence

$$|\vec{V}| = \sqrt{1^2 + 199.5^2 + 53^2} = 206.42 \text{ ft/sec}$$

To find the acceleration

$$\begin{aligned}
 \vec{a} &= \ddot{\vec{R}} + \ddot{\vec{\rho}}_r + \vec{\omega} \times \dot{\vec{\rho}}_r + \dot{\vec{\omega}} \times \vec{\rho} + \vec{\omega} \times (\dot{\vec{\rho}}_r + \vec{\omega} \times \vec{\rho}) \\
 &= \ddot{\vec{R}} + \ddot{\vec{\rho}}_r + \vec{\omega} \times \dot{\vec{\rho}}_r + \dot{\vec{\omega}} \times \vec{\rho} + \vec{\omega} \times \dot{\vec{\rho}}_r + (\vec{\omega} \times (\vec{\omega} \times \vec{\rho})) \\
 &= \ddot{\vec{R}} + \ddot{\vec{\rho}}_r + 2\vec{\omega} \times \dot{\vec{\rho}}_r + \dot{\vec{\omega}} \times \vec{\rho} + (\vec{\omega} \times (\vec{\omega} \times \vec{\rho}))
 \end{aligned} \tag{2}$$

Now each term is found.

$$\begin{aligned}
 \ddot{\vec{R}} &= \frac{d}{dt}(\dot{\vec{R}}) = 3\vec{k} + (\dot{\alpha}\vec{i} + \dot{\beta}\vec{j}) \times (200\vec{j} + 3t\vec{k}) \\
 &= 3\vec{k} + (0.1\vec{i} + 0.2\vec{j}) \times (200\vec{j} + 3t\vec{k}) \\
 &= 3\vec{k} + 20\vec{k} - 0.3t\vec{j} + 0.6t\vec{i} \\
 &= 0.6t\vec{i} - 0.3t\vec{j} + 23\vec{k}
 \end{aligned}$$

$$\ddot{\vec{\rho}}_r = \ddot{s}\vec{k} - \frac{\dot{s}^2}{r}\vec{j}$$

$$\dot{\vec{\omega}} = \underbrace{\frac{d}{dt}(\dot{\alpha}\vec{i})}_{\ddot{\alpha}\vec{i} + (\dot{\beta}\vec{j} \times \dot{\alpha}\vec{i})} + \underbrace{\frac{d}{dt}(\dot{\beta}\vec{j})}_{\dot{\beta}\vec{j} + (\dot{\alpha}\vec{i} \times \dot{\beta}\vec{j})}$$

$$\begin{aligned}
 \dot{\vec{\omega}} &= \ddot{\alpha}\vec{i} - \dot{\beta}\dot{\alpha}\vec{k} + \dot{\beta}\vec{j} + \dot{\alpha}\dot{\beta}\vec{k} \\
 &= \ddot{\alpha}\vec{i} + \dot{\beta}\vec{j}
 \end{aligned}$$

Now all the terms have been found, then Eq. (2) becomes

$$\begin{aligned}
 \vec{a} &= \ddot{\vec{R}} + \ddot{\vec{\rho}}_r + 2\vec{\omega} \times \dot{\vec{\rho}}_r + \dot{\vec{\omega}} \times \vec{\rho} + (\vec{\omega} \times (\vec{\omega} \times \vec{\rho})) \\
 &= (0.6t \vec{i} - 0.3t \vec{j} + 23\vec{k}) + \ddot{s}\vec{k} - \frac{\dot{s}^2}{r} \vec{j} \\
 &\quad + 2(\dot{\alpha} \vec{i} + \dot{\beta} \vec{j}) \times \dot{s}\vec{k} \\
 &\quad + (\ddot{\alpha} \vec{i} + \ddot{\beta} \vec{j}) \times ((L+r) \vec{j} + r\vec{k}) \\
 &\quad + (\dot{\alpha} \vec{i} + \dot{\beta} \vec{j}) \times ((\dot{\alpha} \vec{i} + \dot{\beta} \vec{j}) \times ((L+r) \vec{j} + r\vec{k}))
 \end{aligned}$$

Hence

$$\begin{aligned}
 \vec{a} &= (0.6t \vec{i} - 0.3t \vec{j} + 23\vec{k}) + \ddot{s}\vec{k} - \frac{\dot{s}^2}{r} \vec{j} \\
 &\quad + 2(-\dot{\alpha}\dot{s} \vec{j} + \dot{\beta}\dot{s} \vec{i}) \\
 &\quad + \ddot{\alpha}(L+r) \vec{k} - \ddot{\alpha}r \vec{j} + \ddot{\beta}r \vec{i} \\
 &\quad + (\dot{\alpha} \vec{i} + \dot{\beta} \vec{j}) \times (\dot{\alpha}(L+r) \vec{k} - \dot{\alpha}r \vec{j} + \dot{\beta}r \vec{i})
 \end{aligned}$$

Therefore

$$\begin{aligned}
 \vec{a} &= (0.6t \vec{i} - 0.3t \vec{j} + 23\vec{k}) + \ddot{s}\vec{k} - \frac{\dot{s}^2}{r} \vec{j} \\
 &\quad + 2(-\dot{\alpha}\dot{s} \vec{j} + \dot{\beta}\dot{s} \vec{i}) \\
 &\quad + \ddot{\alpha}(L+r) \vec{k} - \ddot{\alpha}r \vec{j} + \ddot{\beta}r \vec{i} \\
 &\quad - \dot{\alpha}^2(L+r) \vec{j} - \dot{\alpha}^2r \vec{k} + \dot{\beta}\dot{\alpha}(L+r) \vec{i} - \dot{\beta}^2r \vec{k}
 \end{aligned}$$

Collecting terms

$$\vec{a} = \vec{i} \left( 0.6t + 2\dot{\beta}\dot{s} + \ddot{\beta}r + \dot{\beta}\dot{\alpha}(L+r) \right) + \vec{j} \left( -0.3t - \frac{\dot{s}^2}{r} - 2\dot{\alpha}\dot{s} - \ddot{\alpha}r - \dot{\alpha}^2(L+r) \right) + \vec{k} \left( 23 + \ddot{s} + \ddot{\alpha}(L+r) - \dot{\alpha}^2r - \dot{\beta}^2r \right)$$

Since angular accelerations are constants, the above simplifies to

$$\vec{a} = \vec{i} \left( 0.6t + 2\dot{\beta}\dot{s} + \dot{\beta}\dot{\alpha}(L+r) \right) + \vec{j} \left( -0.3t - \frac{\dot{s}^2}{r} - 2\dot{\alpha}\dot{s} - \dot{\alpha}^2(L+r) \right) + \vec{k} \left( 23 + \ddot{s} - \dot{\alpha}^2r - \dot{\beta}^2r \right)$$

Now  $\ddot{s} = -5$ , hence at snapshot where,  $t = 10 \text{ sec}$ ,  $r = 5'$ ,  $L = 25'$ ,  $\dot{\beta} = 0.2 \text{ rad/sec}$ ,  $\dot{\alpha} =$



$0.1 \text{ rad/sec}$ ,  $\dot{s} = 70 - 5t$  the above becomes

$$\begin{aligned}\vec{a} &= \vec{i} (6 + 2(0.2)(70 - 50) + 0.2(0.1)(25 + 5)) + \vec{j} \left( -3 - \frac{(70 - 50)^2}{5} - 2(0.1)(70 - 50) - 0.1^2(25 + 5) \right) \\ &\quad + \vec{k} (23 - 5 - 0.1^2(5) - 0.2^2(5)) \\ &= 14.6 \vec{i} - 87.3 \vec{j} + 17.75 \vec{k}\end{aligned}$$

Hence

$$|\vec{a}| = \sqrt{14.6^2 + 87.3^2 + 17.75^2} = 90.275 \text{ ft/sec}^2$$

## 4.5.3 key solution

## EMA 542

## Home Work to be Handed In

- 4) The pendulum shown in the figure consists of two rods.  $AB$  is pin-supported at  $A$  and swings only in the  $Y-Z$  plane, whereas a bearing at  $B$  allows the attached rod  $BD$  to spin about rod  $AB$ . At a given instant, the rods have the angular motions shown. If a collar  $C$  is located  $0.2$  m from  $B$ , has a velocity of  $3.0$  m/s and an acceleration of  $2.0$  m/s<sup>2</sup> along the rod, determine the velocity and acceleration of the collar at this instant.

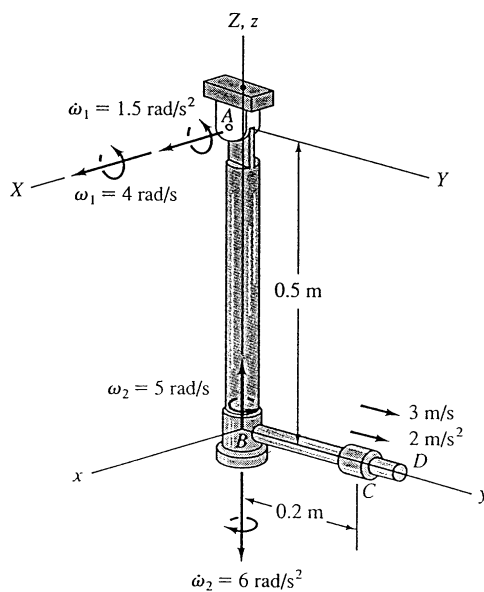

use a single coord. syst. attached to  $O$ ,  
 $xyz$

$$\underline{\dot{\rho}}_r = 3\bar{j} \quad \underline{\ddot{\rho}}_r = 2\bar{j} \quad \underline{\vec{\rho}} = .2\bar{j}$$

$$\underline{\vec{\omega}} = 4\bar{i} + 5\bar{k} = \omega_1\bar{i} + \omega_2\bar{k}$$

$$\underline{\dot{\omega}} = \dot{\omega}_1\bar{i} + (-\omega_2\bar{k} \times \omega_1\bar{i}) + \dot{\omega}_2\bar{k}$$

note that a observer in the  $xyz$  frame sees  
 $\underline{\vec{\omega}}$  rotate with an angular velocity  $-\underline{\vec{\omega}}_2$

$$\therefore \underline{\dot{\omega}} = 1.5\bar{i} - 20\bar{j} - 6\bar{k}$$

$$\underline{\vec{R}}_o = -.5\bar{k} \quad \underline{\dot{\vec{R}}}_o = 2\bar{j} \quad \underline{\ddot{\vec{R}}}_o = .75\bar{j} + 8\bar{k}$$

Velocity -  $\underline{\vec{v}}_c = \underline{\dot{\vec{R}}}_o + \underline{\vec{\omega}} \times \underline{\vec{\rho}}_r + \underline{\dot{\rho}}_r$

$$\therefore \underline{\vec{v}}_c = 2\bar{j} + (4\bar{i} + 5\bar{k}) \times .2\bar{j} + 3\bar{j}$$

$$\underline{\vec{v}}_c = -1.0\bar{i} + 5\bar{j} + .8\bar{k}$$

Acc  $\underline{\vec{a}}_c = \underline{\ddot{\vec{R}}}_o + \underline{\vec{\omega}} \times (\underline{\vec{\omega}} \times \underline{\vec{\rho}}_r) + 2\underline{\dot{\omega}} \times \underline{\dot{\rho}}_r + \underline{\ddot{\rho}}_r + \underline{\dot{\omega}} \times \underline{\vec{\rho}}_r$

$$= .75\bar{j} + 8\bar{k} + (4\bar{i} + 5\bar{k}) \times (.8\bar{k} - 1\bar{i})$$

$$+ 2(4\bar{i} + 5\bar{k}) \times 3\bar{j} + 2\bar{j} + (1.5\bar{i} - 20\bar{j} - 6\bar{k}) \times .2\bar{j}$$

- 2 -

$$\vec{a}_c = .75\vec{j} + \cancel{8\vec{k}} - \cancel{32\vec{j}} - \cancel{5\vec{j}} + \cancel{24\vec{k}}$$
$$- \cancel{30\vec{i}} + \cancel{2\vec{j}} + .3\vec{k} + \cancel{1.2\vec{i}}$$

$$\vec{a}_c = -28.8\vec{i} - 5.45\vec{j} + 32.3\vec{k}$$

EM 542

4B

The mass center  $G$  of an airplane has its velocity vector given as a function of time electronically as  $\vec{v}_G = 200\vec{j} + 3t\vec{k}$  (ft/s) where the body axes  $\vec{i}, \vec{j}, \vec{k}$  are shown. Also rate gyros indicate that its pitch rate  $\dot{\alpha}$  is constant at  $\dot{\alpha} = 0.1$  rad/s, its roll rate  $\dot{\beta}$  is constant at  $\dot{\beta} = 0.2$  rad/s and its yaw rate  $\dot{\gamma}$  remains zero. Fluid is flowing along the hydraulic line  $G,A,B,C$  shown, where the portion  $A,B,C$  is a circular path of radius 5 ft in the  $yz$  body plane. The speed of all fluid particles relative to the hydraulic line is given by  $\dot{s} = 70 - 5t$  (ft/s). Determine at the time  $t = 10$  seconds:

- (a) the inertial velocity  $\vec{v}_P$  of the fluid particle instantaneously at  $B$ , and
- (b) its inertial acceleration  $\vec{a}_P$ .

Note: Give all answers in terms of components along the rotating body axes  $\vec{i}, \vec{j}, \vec{k}$ . Please report all terms because they will be graded individually.

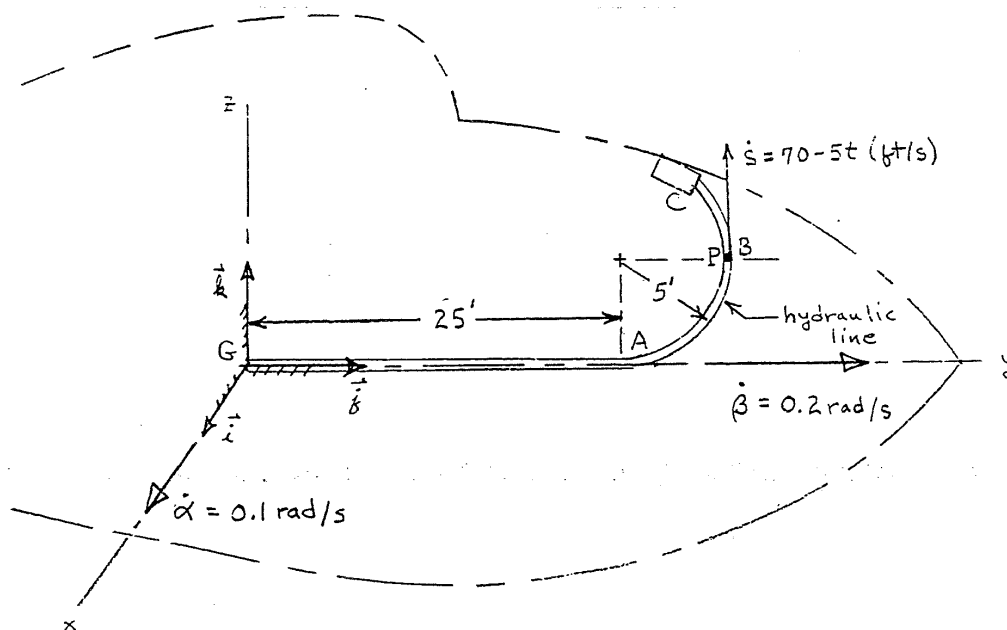

D) Solution

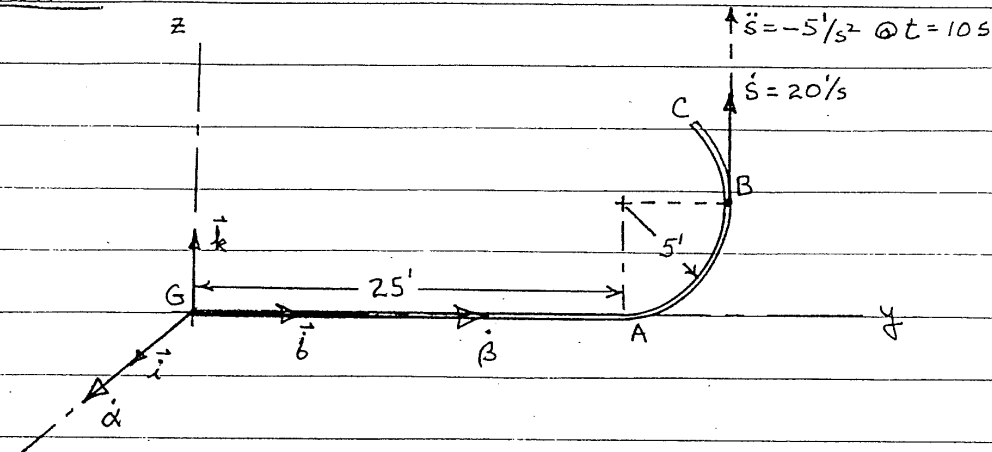

$$\vec{v}_G = 200\vec{j} + 3t\vec{k} \text{ (ft/s)} = (v_G)_y\vec{j} + (v_G)_z\vec{k}$$

$$\dot{\alpha} = 0.1 \text{ rad/s}$$

$$\dot{\beta} = 0.2 \text{ rad/s}$$

$$\begin{aligned} \therefore \vec{a}_G &= (v_G)_y\vec{j} + (v_G)_z\vec{k} + \vec{\omega}_{cs} \times \vec{v}_G \\ &= 3\vec{k} + (0.1\vec{i} + 0.2\vec{j}) \times (200\vec{j} + 3t\vec{k}) \\ &= 3\vec{k} + \{20\vec{k} - 3t\vec{j} + 0.6t\vec{i}\} \end{aligned}$$

$$\text{In general: } \vec{a}_G = 0.6t\vec{i} - 0.3t\vec{j} + 23\vec{k}$$

$$\therefore \text{ @ } t=10\text{s}; \quad \vec{v}_G = 200\vec{j} + 30\vec{k} \text{ (ft/s)}$$

$$\vec{a}_G = 6\vec{i} - 3\vec{j} + 23\vec{k} \text{ (ft/s}^2\text{)}$$

$$\text{Also } \left. \begin{array}{l} \dot{s} = 70 - 5t \\ \ddot{s} = -5 \end{array} \right\} \text{ @ } t=10\text{s}; \quad \left. \begin{array}{l} \dot{s} = 20 \\ \ddot{s} = -5 \end{array} \right\}$$

$$\vec{v}_p = \vec{v}_G + \vec{\omega}_{cs} \times \vec{p} + \dot{\vec{p}}_r$$

$$\text{where: } \vec{v}_G = \underline{200\vec{j} + 30\vec{k}} \text{ at } t=10s$$

$$\left. \begin{aligned} \vec{\omega}_{cs} &= .1\vec{i} + .2\vec{j} \\ \vec{p} &= 30\vec{j} + 5\vec{k} \end{aligned} \right\} \vec{\omega}_{cs} \times \vec{p} = \underline{\vec{i} - .5\vec{j} + 3\vec{k}}$$

$$\dot{\vec{p}}_r = \underline{20\vec{k}}$$

$$\therefore \boxed{\vec{v}_p = \vec{i} + 199.5\vec{j} + 53\vec{k}} \text{ (ft/s)}$$

$$\vec{a}_p = \vec{a}_G + \dot{\vec{\omega}} \times (\vec{\omega} \times \vec{p}) + \dot{\vec{\omega}} \times \vec{p} + 2\vec{\omega} \times \dot{\vec{p}}_r + \ddot{\vec{p}}_r$$

$$\text{where: } \vec{a}_G = \underline{6\vec{i} - 3\vec{j} + 23\vec{k}} \text{ @ } t=10s$$

$$\begin{aligned} \vec{\omega} \times (\vec{\omega} \times \vec{p}) &= (.1\vec{i} + .2\vec{j}) \times (\vec{i} - .5\vec{j} + 3\vec{k}) \\ &= -.05\vec{k} - .3\vec{j} - .2\vec{k} + .6\vec{i} \\ &= \underline{.6\vec{i} - .3\vec{j} - .25\vec{k}} \end{aligned}$$

$$\dot{\vec{\omega}} \times \vec{p} = 0 \text{ since } \dot{\vec{\omega}} = 0$$

$$2\vec{\omega} \times \dot{\vec{p}}_r = 2(.1\vec{i} + .2\vec{j}) \times (20\vec{k}) = \underline{8\vec{i} - 4\vec{j}}$$

$$\ddot{\vec{p}}_r = -5\vec{k} - (20)^2/5\vec{j} = \underline{-80\vec{j} - 5\vec{k}}$$

$$\therefore \boxed{\vec{a}_p = 14.6\vec{i} - 87.3\vec{j} + 17.75\vec{k}}$$

# 4.6 HW 5

## 4.6.1 Problem 1

EMA 542

**Home Work to be Handed In**

5A) A device for simulating conditions in space allows rotations about three orthogonal axes as illustrated in the figure.

At this instant, the astronaut is moving as shown with a velocity  $v_r = 5.0$  ft/sec and an acceleration  $a_r = 32.0$  ft/sec<sup>2</sup>, both relative to the capsule. Use the method of *multiple-rotating-coordinate* systems, with at least two rotating coordinate systems, to determine for the instant pictured:

- (a) the inertial velocity of the astronaut's head;
- (b) the inertial acceleration of the astronaut's head;

given the data in the figures.

$v_r = 5.0$ ft/sec	$a_r = 32.0$ ft/sec <sup>2</sup>
$\omega_1 = 4.0$ rad/sec	$\dot{\omega}_1 = 3.0$ rad/sec <sup>2</sup>
$\omega_2 = 5.0$ rad/sec	$\dot{\omega}_2 = 0.0$ rad/sec <sup>2</sup>
$\omega_3 = 6.0$ rad/sec	$\dot{\omega}_3 = 2.0$ rad/sec <sup>2</sup>

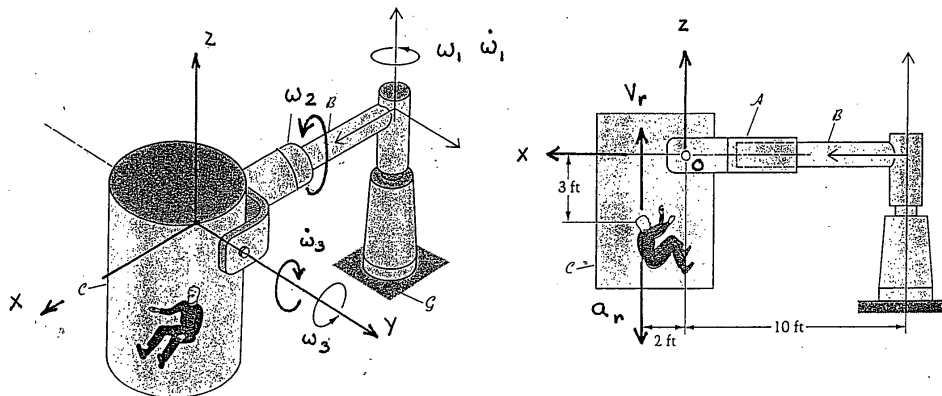



**Solution**

Two rotating coordinates systems are used as shown in this diagram

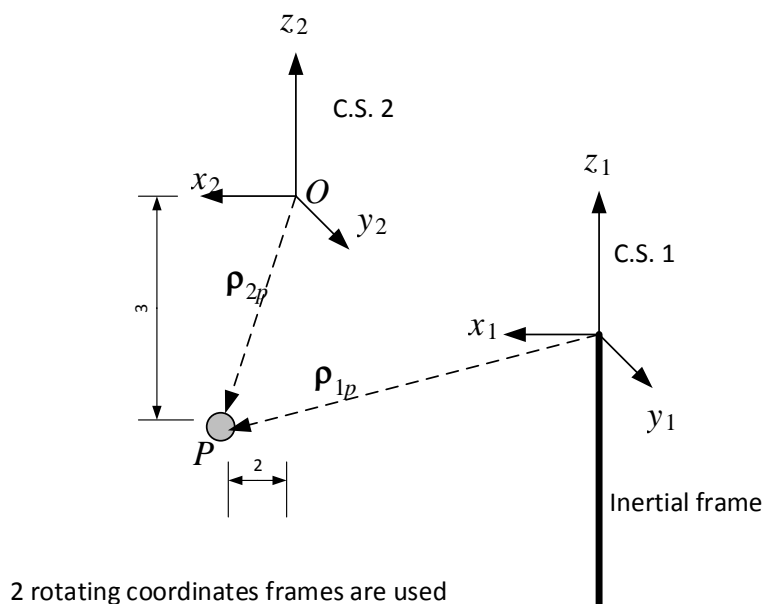

The origin of CS 2 is at point  $O$  and attached to capsule itself. CS 1 origin is at top of column and attached to column.

**4.6.1.1 Velocity calculation****4.6.1.1.1 Motion in 1** (CS 1 is the reference frame now)

$$V_{p/1} = \dot{R}_{o/1} + \omega_{2/1} \times \rho_{2p} + \dot{\rho}_{2p,r}$$

The above is the velocity of point  $P$  as seen in C.S. 1. The vector  $\rho_{2p}$  goes from the origin of C.S. 2 to  $P$ . And the  $\dot{R}_{o/1}$  is the velocity of origin of C.S. 2 as seen in C.S. 1. and  $\dot{\rho}_{2p,r}$  is the velocity of  $P$  relative to C.S. 2. Therefore

$$\rho_{2p} = -3\mathbf{k} + 2\mathbf{i}$$

$$\dot{\rho}_{2p,r} = 5\mathbf{k}$$

$$\dot{R}_{o/1} = 0$$

$$\omega_{2/1} = \omega_3\mathbf{j} + \omega_2\mathbf{i} = 6\mathbf{j} + 5\mathbf{i}$$

Therefore

$$\begin{aligned} V_{p/1} &= (6\mathbf{j} + 5\mathbf{i}) \times (-3\mathbf{k} + 2\mathbf{i}) + 5\mathbf{k} \\ &= -18\mathbf{i} + 15\mathbf{j} - 7\mathbf{k} \end{aligned}$$

### 4.6.1.2 Motion in inertial frame (ground)

$$\mathbf{V}_p = \dot{\mathbf{R}}_1 + \omega_1 \times \rho_{1p} + \dot{\rho}_{1p,r}$$

The above is the absolute velocity of point  $P$ . The vector  $\rho_{1p}$  goes from the origin of C.S. 1 to  $P$ . And the  $\dot{\mathbf{R}}_1$  is the absolute velocity of origin of C.S. 1 and  $\dot{\rho}_{1p,r}$  is the velocity of  $P$  relative to C.S. 1 which we found above as  $\mathbf{V}_{p/1}$ . The only quantity we need to find now is  $\rho_{1p}$ . At the instance shown it is simply

$$\rho_{1p} = 12\mathbf{i} - 3\mathbf{k}$$

But the above is only valid at this instance. Now we can find the absolute velocity

$$\dot{\rho}_{1p,r} = -18\mathbf{i} + 15\mathbf{j} - 7\mathbf{k}$$

$$\dot{\mathbf{R}}_1 = 0$$

$$\omega_1 = \omega_1\mathbf{k} = 4\mathbf{k}$$

Therefore

$$\begin{aligned} \mathbf{V}_p &= 4\mathbf{k} \times (12\mathbf{i} - 3\mathbf{k}) + (-18\mathbf{i} + 15\mathbf{j} - 7\mathbf{k}) \\ &= -18\mathbf{i} + 63\mathbf{j} - 7\mathbf{k} \end{aligned}$$

Hence  $|\mathbf{V}_p| = \sqrt{18^2 + 63^2 + 7^2} = 65.894 \text{ ft/sec.}$

### 4.6.1.3 Acceleration calculation

#### 4.6.1.3.1 Motion in 1 (CS 1 is the reference frame now)

$$\mathbf{a}_{p/1} = \ddot{\mathbf{R}}_{o/1} + 2\left(\omega_{2/1} \times \dot{\rho}_{2p,r}\right) + \left(\dot{\omega}_{2/1} \times \rho_{2p}\right) + \omega_{2/1} \times \left(\omega_{2/1} \times \rho_{2p}\right) + \ddot{\rho}_{2p,r} \quad (1)$$

The above is the acceleration of point  $P$  as seen in C.S. 1.

$$\rho_{2p} = -3\mathbf{k} + 2\mathbf{i}$$

$$\dot{\rho}_{2p,r} = 5\mathbf{k}$$

$$\ddot{\mathbf{R}}_{o/1} = 0$$

$$\omega_{2/1} = \omega_3\mathbf{j} + \omega_2\mathbf{i} = 6\mathbf{j} + 5\mathbf{i}$$

$$\begin{aligned} \dot{\omega}_{2/1} &= \dot{\omega}_3\mathbf{j} + \left(\omega_2\mathbf{i} \times \omega_3\mathbf{j}\right) + \dot{\omega}_2\mathbf{i} + \left(\omega_3\mathbf{j} \times \omega_2\mathbf{i}\right) \\ &= 2\mathbf{j} + \left(5\mathbf{i} \times 6\mathbf{j}\right) + 0\mathbf{i} + \left(6\mathbf{j} \times 5\mathbf{i}\right) \\ &= 2\mathbf{j} + 30\mathbf{k} - 30\mathbf{k} \\ &= 2\mathbf{j} \end{aligned}$$

To find  $\ddot{\rho}_{2p,r}$ , which is acceleration of point  $p$  relative to CS 2, we look at each angular acceleration on its own. Due to  $\omega_2$ , using this diagram

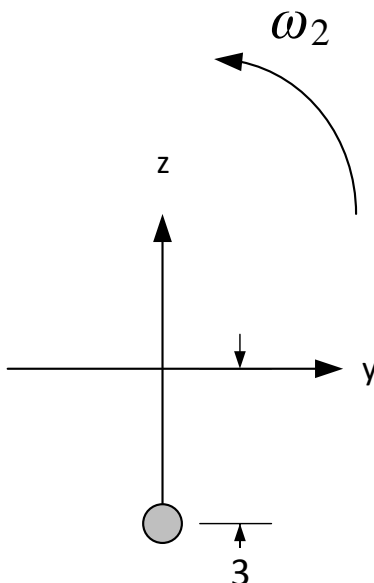

So the point  $p$  appears to move in the opposite direction with tangential acceleration  $(-3\dot{\omega}_2)\mathbf{j}$  and normal acceleration  $3\omega_2^2\mathbf{k}$ . Now looking at effect due to  $\omega_3$  as seen in this diagram

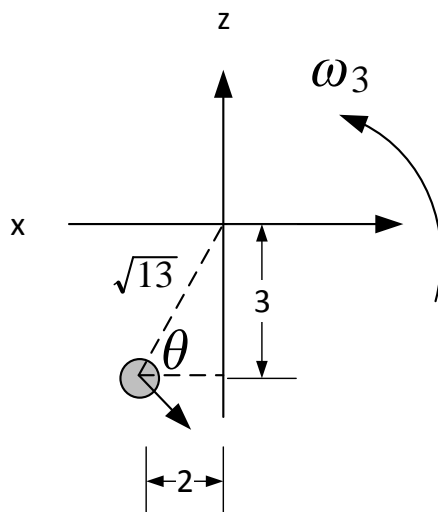

So the point  $p$  appears to move in the opposite direction with tangential acceleration  $-(\sqrt{13}\dot{\omega}_3)\sin\theta\mathbf{i} - (\sqrt{13}\dot{\omega}_3)\cos\theta\mathbf{k}$  and normal acceleration  $-(\sqrt{13}\omega_3^2)\cos\theta\mathbf{i} + (\sqrt{13}\omega_3^2)\sin\theta\mathbf{k}$ . Where  $\theta = \tan^{-1}\left(\frac{3}{2}\right)$ , hence  $\cos\theta = \frac{2}{\sqrt{13}}$  and  $\sin\theta = \frac{3}{\sqrt{13}}$  therefore

$$\begin{aligned} \ddot{\rho}_{2p,r} = & \overbrace{-a_r\mathbf{k} + (-3\dot{\omega}_2)\mathbf{j} + 3\omega_2^2\mathbf{k}}^{\text{due to } \omega_2} \\ & + \overbrace{-(\sqrt{13}\dot{\omega}_3)\sin\theta\mathbf{i} - (\sqrt{13}\dot{\omega}_3)\cos\theta\mathbf{k} - (\sqrt{13}\omega_3^2)\cos\theta\mathbf{i} + (\sqrt{13}\omega_3^2)\sin\theta\mathbf{k}}^{\text{due to } \omega_3} \end{aligned}$$

or (note  $\dot{\omega}_3$  is negative, since it is shown in diagram as moving in clockwise circular arrow)

$$\begin{aligned}\ddot{\rho}_{2p,r} &= -32\mathbf{k} + \overbrace{3(25)\mathbf{k}}^{\text{due to } \omega_2} - (\sqrt{13}(-2)) \frac{3}{\sqrt{13}}\mathbf{i} - (\sqrt{13}(-2)) \frac{2}{\sqrt{13}}\mathbf{k} - (\sqrt{13}36) \frac{2}{\sqrt{13}}\mathbf{i} + (\sqrt{13}36) \frac{3}{\sqrt{13}}\mathbf{k} \\ &= -32\mathbf{k} + 75\mathbf{k} - 6\mathbf{i} - 4\mathbf{k} - 72\mathbf{i} + 108\mathbf{k} \\ &= -76\mathbf{i} + 147\mathbf{k}\end{aligned}$$

Therefore from Eq. (1)

$$\begin{aligned}\mathbf{a}_{p/1} &= \ddot{\mathbf{R}}_{o/1} + 2\left(\omega_{2/1} \times \dot{\rho}_{2p,r}\right) + \left(\dot{\omega}_{2/1} \times \rho_{2p}\right) + \omega_{2/1} \times \left(\omega_{2/1} \times \rho_{2p}\right) + \ddot{\rho}_{2p,r} \\ \mathbf{a}_{p/1} &= 0 + 2\left((6\mathbf{j} + 5\mathbf{i}) \times 5\mathbf{k}\right) + (2\mathbf{j} \times (-3\mathbf{k} + 2\mathbf{i})) + (6\mathbf{j} + 5\mathbf{i}) \times ((6\mathbf{j} + 5\mathbf{i}) \times (-3\mathbf{k} + 2\mathbf{i})) + (-76\mathbf{i} + 147\mathbf{k}) \\ \mathbf{a}_{p/1} &= -94\mathbf{i} + 10\mathbf{j} + 326\mathbf{k}\end{aligned}$$

#### 4.6.1.4 Motion in inertial frame (ground)

$$\mathbf{a}_p = \ddot{\mathbf{R}}_1 + 2\left(\omega_1 \times \dot{\rho}_{1p,r}\right) + \left(\dot{\omega}_1 \times \rho_{1p}\right) + \omega_1 \times \left(\omega_1 \times \rho_{1p}\right) + \ddot{\rho}_{1p,r} \quad (2)$$

The above is the absolute acceleration of point  $P$ . At the instance shown

$$\begin{aligned}\rho_{1p} &= 12\mathbf{i} - 3\mathbf{k} \\ \dot{\rho}_{1p,r} &= -18\mathbf{i} + 15\mathbf{j} - 7\mathbf{k} \\ \ddot{\mathbf{R}}_1 &= 0 \\ \omega_1 &= \omega_1\mathbf{k} = 4\mathbf{k} \\ \dot{\omega}_1 &= \dot{\omega}_1\mathbf{k} = 3\mathbf{k}\end{aligned}$$

and  $\ddot{\rho}_{1p,r}$  we found above which is  $\mathbf{a}_{p/1}$ , hence Eq. (2) becomes

$$\begin{aligned}\mathbf{a}_p &= 2\left(4\mathbf{k} \times (-18\mathbf{i} + 15\mathbf{j} - 7\mathbf{k})\right) + (3\mathbf{k} \times (12\mathbf{i} - 3\mathbf{k})) + 4\mathbf{k} \times (4\mathbf{k} \times (12\mathbf{i} - 3\mathbf{k})) + (-94\mathbf{i} + 10\mathbf{j} + 326\mathbf{k}) \\ &= -406\mathbf{i} - 98\mathbf{j} + 326\mathbf{k}\end{aligned}$$

Therefore

$$\begin{aligned}|\mathbf{a}_p| &= \sqrt{406^2 + 98^2 + 326^2} \\ &= 529.83 \text{ ft/sec}^2\end{aligned}$$

4.6.2 Problem 2

EMA 542

Home Work to be Handed In

5B) The thin disc of radius 1 ft. rotates with a constant angular velocity  $\omega_1 = 10 \text{ rad/sec}$  in bearings A and B. The weightless arm containing the bearings rotates about the fixed point O as shown with the angular velocity  $\omega_2 = 1 \text{ rad/sec}$  and angular acceleration  $\alpha_2 = 3 \text{ rad/sec}^2$ . The vertical shaft CD rotates as shown with an angular velocity  $\omega_3 = 2 \text{ rad/sec}$  and angular acceleration  $\alpha_3 = 4 \text{ rad/sec}^2$ . Calculate the absolute velocity and acceleration of point Q at the top of the disk for the position shown.

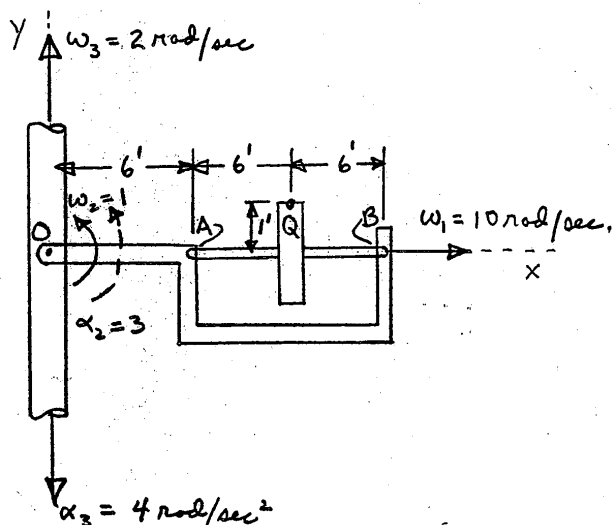

Two rotating CS are used as shown in this diagram

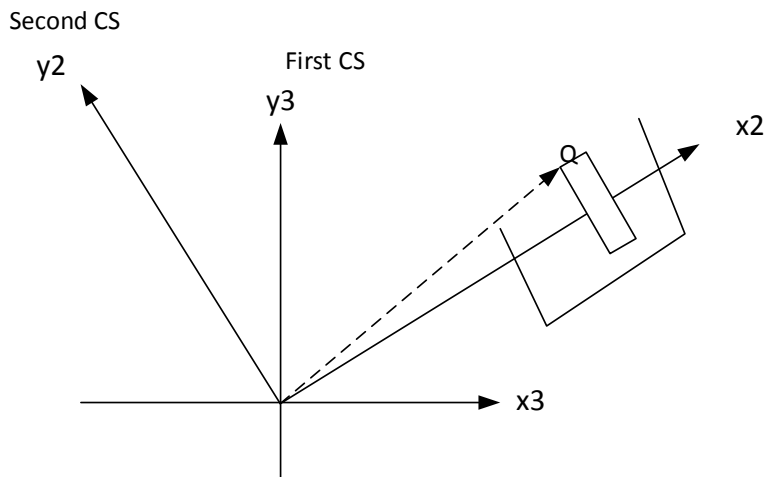

The origin of CS 2 and CS 1 are both at the same point is at point  $O$

#### 4.6.2.1 Velocity calculation

##### 4.6.2.1.1 Motion in first CS (first CS is the reference frame now)

$$V_{Q/1} = \dot{R}_{2/1} + \omega_{2/1} \times \rho_{2Q} + \dot{\rho}_{2Q,r}$$

The above is the velocity of point  $Q$  as seen in first C.S. The vector  $\rho_{2p}$  goes from the origin of second C.S. to  $Q$ . And the  $\dot{R}_{2/1}$  is the velocity of origin of second C.S. as seen in first C.S. and  $\dot{\rho}_{2Q,r}$  is the velocity of  $Q$  relative to second C.S. Therefore

$$\begin{aligned}\rho_{2Q} &= 6\mathbf{i} + \mathbf{j} \\ \dot{\rho}_{2p,r} &= (1 \times \omega_1) \mathbf{k} = 10\mathbf{k} \\ \dot{R}_{2/1} &= 0 \\ \omega_{2/1} &= \omega_2 \mathbf{k} = \mathbf{k}\end{aligned}$$

Therefore

$$\begin{aligned}V_{Q/1} &= \mathbf{k} \times (6\mathbf{i} + \mathbf{j}) + 10\mathbf{k} \\ &= -\mathbf{i} + 6\mathbf{j} + 10\mathbf{k}\end{aligned}$$

##### 4.6.2.1.2 Motion in inertial frame (ground)

$$V_Q = \dot{R}_1 + \omega_{first} \times \rho_{1Q} + \dot{\rho}_{1Q,r}$$

The above is the absolute velocity of point  $Q$ . The vector  $\rho_{1Q}$  goes from the origin of first C.S. to  $Q$ . And the  $\dot{R}_1$  is the absolute velocity of origin of first C.S. and  $\dot{\rho}_{1Q,r}$  is the velocity of  $Q$  relative to first C.S. which we found above as  $V_{Q/1}$ . The only quantity we need to find now is  $\rho_{1Q}$ . At the instance shown it is simply

$$\rho_{1p} = 6\mathbf{i} + \mathbf{j}$$

But the above is only valid at this instance. Now we can find the absolute velocity

$$\begin{aligned}\dot{\rho}_{1Q,r} &= -i + 6j + 10k \\ \dot{\mathbf{R}}_1 &= 0 \\ \omega_{first} &= \omega_3 j = 2j\end{aligned}$$

Therefore

$$\begin{aligned}V_Q &= 2j \times (6i + j) + (-i + 6j + 10k) \\ &= -i + 6j - 2k\end{aligned}$$

Hence  $|V_Q| = \sqrt{1^2 + 6^2 + 2^2} = 6.403$  ft/sec.

#### 4.6.2.2 Acceleration calculation

##### 4.6.2.2.1 Motion in 1 (first CS is the reference frame now)

$$a_{Q/1} = \ddot{\mathbf{R}}_{2/1} + 2(\omega_{2/1} \times \dot{\rho}_{2Q,r}) + (\dot{\omega}_{2/1} \times \rho_{2Q}) + \omega_{2/1} \times (\omega_{2/1} \times \rho_{2Q}) + \ddot{\rho}_{2Q,r} \quad (1)$$

The above is the acceleration of point Q as seen in first C.S.

$$\begin{aligned}\rho_{2Q} &= 6i + j \\ \dot{\rho}_{2Q,r} &= 10k \\ \ddot{\mathbf{R}}_{2/1} &= 0 \\ \omega_{2/1} &= k \\ \dot{\omega}_{2/1} &= \alpha_2 k + (0 \times k) = 3k\end{aligned}$$

To find  $\ddot{\rho}_{2Q,r}$ , which is acceleration of point Q relative to second CS we look at this diagram

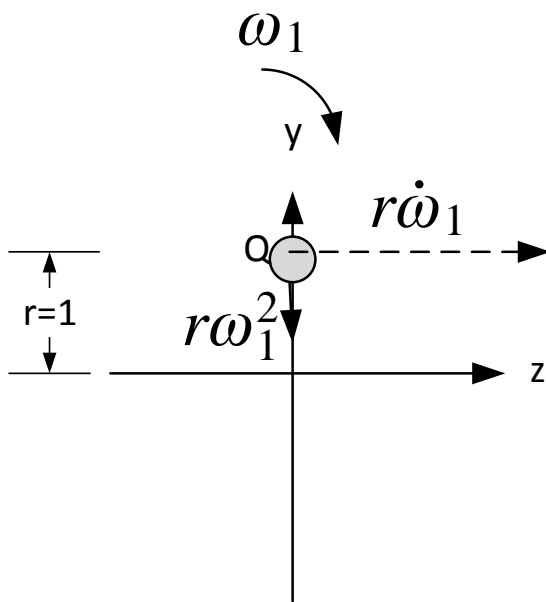

Hence

$$\ddot{\rho}_{2Q,r} = -\omega_1^2 \mathbf{j} = -100\mathbf{j}$$

Therefore from Eq. (1)

$$\begin{aligned} \mathbf{a}_{Q/1} &= \ddot{\mathbf{R}}_{2/1} + 2\left(\omega_{2/1} \times \dot{\rho}_{2Q,r}\right) + \left(\dot{\omega}_{2/1} \times \rho_{2Q}\right) + \omega_{2/1} \times \left(\omega_{2/1} \times \rho_{2Q}\right) + \ddot{\rho}_{2Q,r} \\ \mathbf{a}_{p/1} &= 0 + 2(\mathbf{k} \times 10\mathbf{k}) + (3\mathbf{k} \times (6\mathbf{i} + \mathbf{j})) + \mathbf{k} \times (\mathbf{k} \times (6\mathbf{i} + \mathbf{j})) - 100\mathbf{j} \\ \mathbf{a}_{p/1} &= -9\mathbf{i} - 83\mathbf{j} \end{aligned}$$

#### 4.6.2.2.2 Motion in inertial frame (ground)

$$\mathbf{a}_Q = \ddot{\mathbf{R}}_1 + 2\left(\omega_{first} \times \dot{\rho}_{1Q,r}\right) + \left(\dot{\omega}_{first} \times \rho_{1Q}\right) + \omega_{first} \times \left(\omega_{first} \times \rho_{1Q}\right) + \ddot{\rho}_{1Q,r} \quad (2)$$

The above is the absolute acceleration of point Q. At the instance shown

$$\begin{aligned} \rho_{1Q} &= 6\mathbf{i} + \mathbf{j} \\ \dot{\rho}_{1Q,r} &= \dot{\rho}_{2Q,r} = 10\mathbf{k} \\ \ddot{\mathbf{R}}_1 &= 0 \\ \omega_{first} &= \omega_3 \mathbf{j} = 2\mathbf{j} \\ \dot{\omega}_1 &= -\alpha_3 \mathbf{j} + (0 \times \omega_3 \mathbf{j}) = -4\mathbf{j} \end{aligned}$$

and  $\ddot{\rho}_{1p,r}$  we found above which is  $\mathbf{a}_{p/1}$ , hence Eq. (2) becomes

$$\begin{aligned} \mathbf{a}_p &= 2(2\mathbf{j} \times 10\mathbf{k}) + (-4\mathbf{j} \times (6\mathbf{i} + \mathbf{j})) + 2\mathbf{j} \times (2\mathbf{j} \times (6\mathbf{i} + \mathbf{j})) + (-9\mathbf{i} - 83\mathbf{j}) \\ &= 7\mathbf{i} - 83\mathbf{j} + 24\mathbf{k} \end{aligned}$$

Therefore

$$\begin{aligned} |\mathbf{a}_p| &= \sqrt{7^2 + 83^2 + 24^2} \\ &= 86.683 \text{ ft/sec}^2 \end{aligned}$$



4.6.3 problem 1 done again

problem 5A  
EMA 542

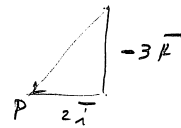
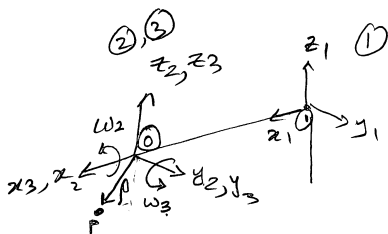

using 3 coordinate systems.

when c.s. (3) is reference; c.s. (2) is rotating

$$\vec{V}_P = \dot{R}_0 + \vec{\omega} \times \vec{r}_{P/O} + \dot{r}_{P/O,r}$$

velocity of P as seen in (3).

$$\vec{V}_P = 0 + \omega_2 \vec{i} \times (-3\vec{k} + 2\vec{i}) + 5\vec{k}$$

$$= 5\vec{i} \times (-3\vec{k} + 2\vec{i}) + 5\vec{k}$$

$$= 15\vec{j} + 5\vec{k}$$

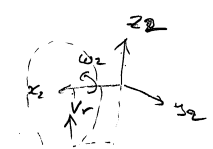

velocity of P relative to c.s. (2)  
velocity of P relative to c.s. (3)  
 $\dot{r}_{P,ref c.s.}$

when c.s. (1) is reference, c.s. (3) is rotating

$$\vec{V}_P = \dot{R}_0 + \vec{\omega} \times \vec{r}_{P/O} + \dot{r}_{P/O,r} \rightarrow \text{we found above} = \vec{V}_P$$

$$\vec{V}_P = 0 + \omega_3 \vec{j} \times (-3\vec{k} + 2\vec{i}) + (5\vec{k} + 15\vec{j})$$

$$= 6\vec{j} \times (-3\vec{k} + 2\vec{i}) + (5\vec{k} + 15\vec{j}) = -18\vec{i} - 12\vec{k} + (5\vec{k} + 15\vec{j}) = -18\vec{i} - 7\vec{k} + 15\vec{j}$$

velocity of P relative to c.s. (1)

when ground is reference

$$\vec{V}_P = \dot{R}_0 + \vec{\omega} \times \vec{r}_{P/O} + \dot{r}_{P/O,r} \rightarrow \text{we found above.}$$

$$\vec{V}_P = 0 + \omega_1 \vec{k} \times (12\vec{i} - 3\vec{k}) + (-18\vec{i} - 7\vec{k} + 15\vec{j})$$

$$= 4\vec{k} \times (12\vec{i} - 3\vec{k}) + (-18\vec{i} - 7\vec{k} + 15\vec{j})$$

$$= 63\vec{j} - 18\vec{i} - 7\vec{k} = \boxed{-18\vec{i} + 63\vec{j} - 7\vec{k}} = \boxed{65.89 \text{ ft/sec}}$$

Acceleration  $\ddot{\mathbf{a}} = \ddot{\mathbf{R}} + 2(\dot{\boldsymbol{\omega}} \times \dot{\mathbf{r}}_r) + (\ddot{\boldsymbol{\omega}} \times \mathbf{r}) + \dot{\boldsymbol{\omega}} \times (\boldsymbol{\omega} \times \mathbf{r}) + \ddot{\mathbf{r}}_r$

when C.S. (3) is reference. C.S. 2 is rotating

$$\ddot{\mathbf{a}}_p = \ddot{\mathbf{R}}_0 + 2(\dot{\boldsymbol{\omega}} \times \dot{\mathbf{r}}_r) + (\ddot{\boldsymbol{\omega}} \times \mathbf{r}) + \dot{\boldsymbol{\omega}} \times (\boldsymbol{\omega} \times \mathbf{r}) + \ddot{\mathbf{r}}_r$$

$$\ddot{\mathbf{R}}_0 = 0, \quad \boldsymbol{\omega} = \omega_2 \mathbf{i}, \quad \mathbf{r} = (-3\mathbf{k} + 2\mathbf{i}), \quad \dot{\boldsymbol{\omega}} = \dot{\omega}_2 \mathbf{i} + (0 \times \omega_2 \mathbf{i})$$

$$\text{so } \dot{\boldsymbol{\omega}} = 5\mathbf{i}, \quad \mathbf{r} = (-3\mathbf{k} + 2\mathbf{i}), \quad \ddot{\boldsymbol{\omega}} = 0$$

now  $\ddot{\mathbf{r}}_r$  is found.

$$\ddot{\mathbf{r}}_r = -a_r \mathbf{k} + 3\dot{\omega}_2 \mathbf{j} + \omega_2 \mathbf{k}$$

$$= -32\mathbf{k} + 45\mathbf{k} = 13\mathbf{k}$$

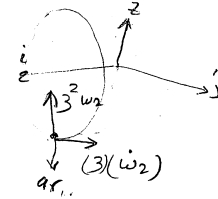

$$\text{so } \ddot{\mathbf{a}}_p = 2(5\mathbf{i} \times (-5\mathbf{k})) + (0 \times \mathbf{r}) + 5\mathbf{i} \times (5\mathbf{i} \times (-3\mathbf{k} + 2\mathbf{i})) + 13\mathbf{k}$$

$$= 2(-25\mathbf{k}) + 5\mathbf{i} \times (15\mathbf{j}) + 13\mathbf{k}$$

$$= -50\mathbf{k} + 75\mathbf{k} + 13\mathbf{k} = 38\mathbf{k}$$

acc. of P relative to C.S. (3)

when C.S. (1) is reference. C.S. (3) is rotating

$$\ddot{\mathbf{a}}_p = \ddot{\mathbf{R}}_0 + 2(\dot{\boldsymbol{\omega}} \times \dot{\mathbf{r}}_r) + (\ddot{\boldsymbol{\omega}} \times \mathbf{r}) + \dot{\boldsymbol{\omega}} \times (\boldsymbol{\omega} \times \mathbf{r}) + \ddot{\mathbf{r}}_r$$

$$\ddot{\mathbf{R}}_0 = 0, \quad \boldsymbol{\omega} = \omega_3 \mathbf{j} = 6\mathbf{j}, \quad \mathbf{r} = (-3\mathbf{k} + 2\mathbf{i}), \quad \dot{\mathbf{r}}_r = (5\mathbf{k}) \text{ from last page.}$$

$$\dot{\boldsymbol{\omega}} = -\dot{\omega}_3 \mathbf{j} + (\omega_2 \mathbf{i} \times \omega_3 \mathbf{j}) = -2\mathbf{j} + (5\mathbf{i} \times 6\mathbf{j}) = -2\mathbf{j} + 30\mathbf{k}$$

$$\text{so } \ddot{\mathbf{a}}_p = 0 + 2(6\mathbf{j} \times (5\mathbf{k} + 15\mathbf{j})) + (-2\mathbf{j} + 30\mathbf{k}) \times (-3\mathbf{k} + 2\mathbf{i}) + (6\mathbf{j} \times (6\mathbf{j} \times (-3\mathbf{k} + 2\mathbf{i}))) + 38\mathbf{k}$$

$$= 30\mathbf{i} + (20\mathbf{j}) + 6\mathbf{j} \times (-18\mathbf{i} - 12\mathbf{k}) + 38\mathbf{k}$$

$$= 30\mathbf{i} + 20\mathbf{j} + 108\mathbf{k} - 72\mathbf{i} + 38\mathbf{k} = -42\mathbf{i} + 20\mathbf{j} + 146\mathbf{k}$$

acc. of P relative to C.S. (1)

when ground is reference, C.S. (1) is rotating

$$\ddot{\mathbf{a}}_p = \ddot{\mathbf{R}}_1 + 2(\dot{\boldsymbol{\omega}} \times \dot{\mathbf{r}}_r) + (\ddot{\boldsymbol{\omega}} \times \mathbf{r}) + \dot{\boldsymbol{\omega}} \times (\boldsymbol{\omega} \times \mathbf{r}) + \ddot{\mathbf{r}}_r$$

$$\ddot{\mathbf{R}}_1 = 0, \quad \dot{\mathbf{r}}_r = -18\mathbf{i} - 7\mathbf{k} + 15\mathbf{j} \text{ from last page, } \mathbf{r} = 12\mathbf{i} - 3\mathbf{k}$$

$$\dot{\boldsymbol{\omega}} = \dot{\omega}_1 \mathbf{k} + (0 \times \omega_1 \mathbf{k}) = \omega_1 \mathbf{k} = 3\mathbf{k}, \quad \boldsymbol{\omega} = \omega_1 \mathbf{k} = 4\mathbf{k}$$

$$\text{so } \ddot{\mathbf{a}}_p = 2(4\mathbf{k} \times (-18\mathbf{i} - 7\mathbf{k} + 15\mathbf{j})) + 3\mathbf{k} \times (4\mathbf{k} \times (12\mathbf{i} - 3\mathbf{k})) + (-42\mathbf{i} + 20\mathbf{j} + 146\mathbf{k})$$

$$= 2(-72\mathbf{j} + 60\mathbf{i}) + 4\mathbf{k} \times (48\mathbf{j}) - 42\mathbf{i} + 20\mathbf{j} + 146\mathbf{k}$$

$$= -144\mathbf{j} - 120\mathbf{i} - 192\mathbf{i} - 42\mathbf{i} + 20\mathbf{j} + 146\mathbf{k}$$

$$= \mathbf{i}(-314) + \mathbf{j}(-124) + \mathbf{k}(146) = 367.8 \text{ ft/sec}^2$$

$$\begin{aligned}
 \bar{a}_p &= 2(6\bar{j} \times (5\bar{k} + 15\bar{j})) + ((-2\bar{j} + 30\bar{k}) \times (-3\bar{k} + 2\bar{i})) + 6\bar{j} \times (6\bar{j} \times (-3\bar{k} + 7\bar{i})) + 3\bar{j}\bar{k} \\
 &= 2(30\bar{i}) + (6\bar{i} + 4\bar{k} + 60\bar{j}) + 6\bar{j} \times (-18\bar{i} - 12\bar{k}) + 3\bar{j}\bar{k} \\
 &= 60\bar{i} + 6\bar{i} + 4\bar{k} + 60\bar{j} + 108\bar{k} - 72\bar{i} + 3\bar{j}\bar{k} \\
 &= \bar{i}(60 + 6 - 72) + \bar{j}(60) + \bar{k}(4 + 108 + 3\bar{j}) \\
 &= -6\bar{i} + 60\bar{j} + 150\bar{k} \rightarrow \text{acc. of } P \text{ relative to. c.s. } \textcircled{1}
 \end{aligned}$$

When ground is reference. c.s. (1) is rotating

$$\begin{aligned}
 \ddot{R}_1 &= 0, \quad \bar{p}_r = 12\bar{i} - 3\bar{k}, \quad \bar{\omega} = \omega_1 \bar{k} = 4\bar{k}, \quad \dot{\bar{p}}_r = (-18\bar{i} - 7\bar{k} + 15\bar{j}) \\
 \ddot{\bar{\omega}} &= \dot{\omega}_1 \bar{k} = 3\bar{k}, \quad \ddot{\bar{p}}_r = -6\bar{i} + 60\bar{j} + 150\bar{k}
 \end{aligned}$$

$$\begin{aligned}
 \text{si } \bar{a}_p &= 2(4\bar{k} \times (-18\bar{i} - 7\bar{k} + 15\bar{j})) + 3\bar{k} \times (12\bar{i} - 3\bar{k}) + 4\bar{k} \times (4\bar{k} \times (12\bar{i} - 3\bar{k})) \\
 &\quad + (-6\bar{i} + 60\bar{j} + 150\bar{k}) \\
 &= 2(-72\bar{j} - 60\bar{i}) + (36\bar{j}) + 4\bar{k} \times (48\bar{j}) + (-6\bar{i} + 60\bar{j} + 150\bar{k}) \\
 &= -144\bar{j} - 120\bar{i} + 36\bar{j} + 192\bar{i} - 6\bar{i} + 60\bar{j} + 150\bar{k} \\
 &= \bar{i}(-120 - 192 - 6) + \bar{j}(-144 + 36 + 60) + \bar{k}(150) \\
 &= \boxed{-318\bar{i} - 48\bar{j} + 150\bar{k}} = 354.86 \text{ ft/sec}^2
 \end{aligned}$$

4.6.4 key solution

EMA 542  
Home Work to be Handed In

5A) A device for simulating conditions in space allows rotations about three orthogonal axes as illustrated in the figure.

At this instant, the astronaut is moving as shown with a velocity  $v_r = 5.0$  ft/sec and an acceleration  $a_r = 32.0$  ft/sec<sup>2</sup>, both relative to the capsule. Use the method of *multiple-rotating-coordinate* systems, with at least two rotating coordinate systems, to determine for the instant pictured:

- (a) the inertial velocity of the astronaut's head;
- (b) the inertial acceleration of the astronaut's head;

given the data in the figures.

$v_r = 5.0$ ft/sec	$a_r = 32.0$ ft/sec <sup>2</sup>
$\omega_1 = 4.0$ rad/sec	$\dot{\omega}_1 = 3.0$ rad/sec <sup>2</sup>
$\omega_2 = 5.0$ rad/sec	$\dot{\omega}_2 = 0.0$ rad/sec <sup>2</sup>
$\omega_3 = 6.0$ rad/sec	$\dot{\omega}_3 = 2.0$ rad/sec <sup>2</sup>

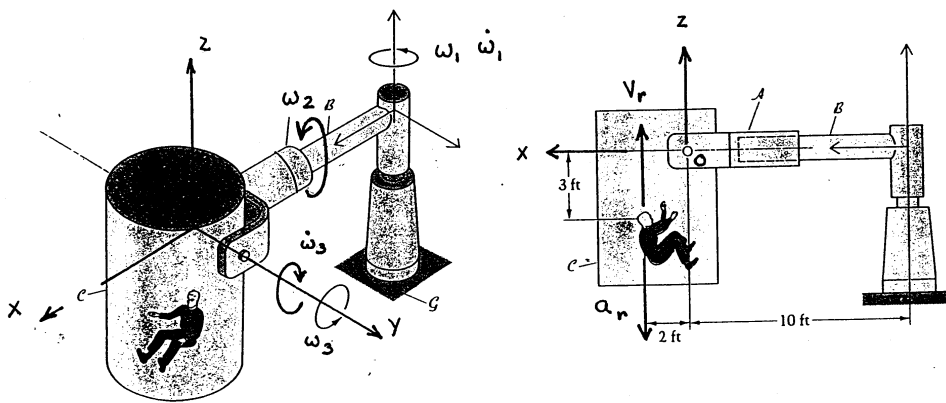

SOLUTION TO 5A - BMA 542

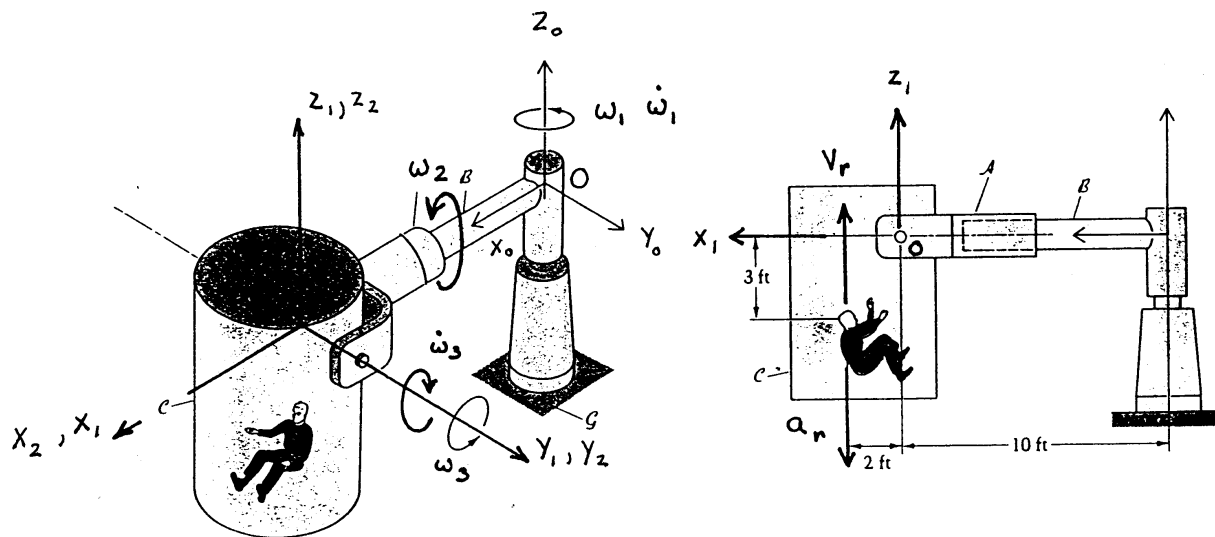

USE 2 ROTATING COORDINATE SYSTEMS, 1 & 2  
AS SHOWN ABOVE.

$$\vec{\omega}_{1/0} = \omega_1 \bar{k} + \omega_2 \bar{i} = 4\bar{k} + 5\bar{i}$$

$$\vec{\omega}_{2/1} = \omega_3 \bar{j} = 6\bar{j}$$

$$\dot{\vec{\omega}}_{1/0} = \dot{\omega}_1 \bar{k} + \omega_1 \bar{k} \times \omega_2 \bar{i} = 3\bar{k} + 20\bar{j}$$

$$\dot{\vec{\omega}}_{2/1} = \dot{\omega}_3 \bar{j} = -2\bar{j}$$

MOTION IN ① COORDINATE SYSTEM:

$$\vec{v}_1 = \dot{\vec{R}}_2 + \vec{\omega}_{2/1} \times \vec{p}_2 + \dot{\vec{p}}_2 \quad \text{①}$$

- 2 -

$$\dot{\vec{R}}_2 = 0 \quad \vec{\rho}_2 = 2\vec{i} - 3\vec{j}$$

$$\vec{\omega}_{2/1} \times \vec{\rho}_2 = 6\vec{j} \times (2\vec{i} - 3\vec{j}) = -12\vec{k} - 18\vec{i}$$

$$\dot{\vec{\rho}}_{2r} = 5\vec{j}$$

$$\Rightarrow \vec{v}_1 = -18\vec{i} - 7\vec{j} \quad (2)$$

$$\vec{a}_1 = \ddot{\vec{R}}_2 + \vec{\omega}_{2/1} \times (\vec{\omega}_{2/1} \times \vec{\rho}_2) + \dot{\vec{\omega}}_{2/1} \times \vec{\rho}_2 \\ + 2 \vec{\omega}_{2/1} \times \dot{\vec{\rho}}_{2r} + \ddot{\vec{\rho}}_{2r}$$

$$\ddot{\vec{R}}_2 = 0 \quad \vec{\omega}_{2/1} \times (\vec{\omega}_{2/1} \times \vec{\rho}_2) = 6\vec{j} \times (-12\vec{k} - 18\vec{i})$$

$$\therefore \vec{\omega}_{2/1} \times (\vec{\omega}_{2/1} \times \vec{\rho}_2) = -72\vec{i} + 108\vec{j} \quad (3)$$

$$\dot{\vec{\omega}}_{2/1} \times \vec{\rho}_2 = -2\vec{j} \times (2\vec{i} - 3\vec{j}) = 4\vec{k} + 6\vec{i} \quad (4)$$

$$2 \vec{\omega}_{2/1} \times \dot{\vec{\rho}}_{2r} = 2(6\vec{j}) \times 5\vec{j} = 60\vec{i} \quad (5)$$

$$\ddot{\vec{\rho}}_{2r} = -32\vec{j}$$

$$\therefore \vec{a}_1 = (-72 + 6 + 60)\vec{i} + (108 + 4 - 32)\vec{j}$$

- 3 -

$$\vec{a}_1 = -6\vec{i} + 80\vec{j} \quad (6)$$

Motion in O on fixed coordinate system:

$$\vec{v}_0 = \dot{\vec{R}}_1 + \vec{\omega}_{110} \times \vec{r}_1 + \dot{\vec{r}}_{1r} \quad \vec{r}_1 = 2\vec{i} - 3\vec{j}$$

$$\dot{\vec{R}}_1 = \omega_1 (10)\vec{j} = 40\vec{j} \quad (7)$$

$$\begin{aligned} \vec{\omega}_{110} \times \vec{r}_1 &= (4\vec{j} + 5\vec{i}) \times (2\vec{i} - 3\vec{j}) \\ &= 8\vec{j} + 15\vec{j} = 23\vec{j} \end{aligned} \quad (8)$$

$$\dot{\vec{r}}_{1r} = \vec{v}_1 = -18\vec{i} - 7\vec{j}$$

$$\therefore \underline{\vec{v}_0} = -18\vec{i} + 63\vec{j} - 7\vec{j} \quad (9)$$

$$\begin{aligned} \vec{a}_0 &= \ddot{\vec{R}}_1 + \vec{\omega}_{110} \times (\vec{\omega}_{110} \times \vec{r}_1) + \dot{\vec{\omega}}_{110} \times \vec{r}_1 \\ &\quad + 2\vec{\omega}_{110} \times \dot{\vec{r}}_{1r} + \ddot{\vec{r}}_{1r} \end{aligned}$$

$$\ddot{\vec{R}}_1 = 10\dot{\omega}_1\vec{j} - 10(\omega_1^2)\vec{i} = 30\vec{j} - 160\vec{i} \quad (10)$$

$$\vec{\omega}_{110} \times (\vec{\omega}_{110} \times \vec{r}_1) = (4\vec{j} + 5\vec{i}) \times 23\vec{j} = -92\vec{i} + 115\vec{j} \quad (11)$$

$$\dot{\vec{\omega}}_{110} \times \vec{r}_1 = (3\vec{j} + 20\vec{i}) \times (2\vec{i} - 3\vec{j})$$

- 4 -

$$\Rightarrow \dot{\vec{\omega}}_{110} \times \vec{r}_1 = 6\vec{j} - 40\vec{k} - 60\vec{i} \quad (12)$$

$$\begin{aligned} 2 \vec{\omega}_{110} \times \dot{\vec{r}}_{1r} &= 2(4\vec{k} + 5\vec{i}) \times (-18\vec{i} - 7\vec{k}) \\ &= -144\vec{j} + 70\vec{j} = -74\vec{j} \quad (13) \end{aligned}$$

$$\ddot{\vec{r}}_{1r} = \vec{a}_1 = -6\vec{i} + 80\vec{k}$$

$$\begin{aligned} \therefore \vec{a}_0 &= (-160 - 92 - 60 - 6)\vec{i} \\ &\quad + (30 + 6 - 74)\vec{j} + (115 - 40 + 80)\vec{k} \end{aligned}$$

$$\Rightarrow \underline{\vec{a}_0} = -318\vec{i} - 38\vec{j} + 155\vec{k} \quad (14)$$



## EMA 542

## Home Work to be Handed In

**5B)** The thin disc of radius 1 ft. rotates with a constant angular velocity  $\omega_1 = 10 \text{ rad/sec}$  in bearings A and B. The weightless arm containing the bearings rotates about the fixed point O as shown with the angular velocity  $\omega_2 = 1 \text{ rad/sec}$  and angular acceleration  $\alpha_2 = 3 \text{ rad/sec}^2$ . The vertical shaft CD rotates as shown with an angular velocity  $\omega_3 = 2 \text{ rad/sec}$  and angular acceleration  $\alpha_3 = 4 \text{ rad/sec}^2$ . Calculate the absolute velocity and acceleration of point Q at the top of the disk for the position shown.

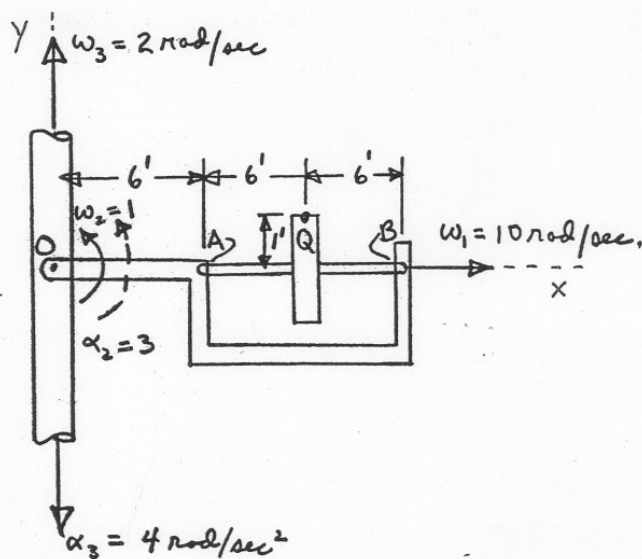

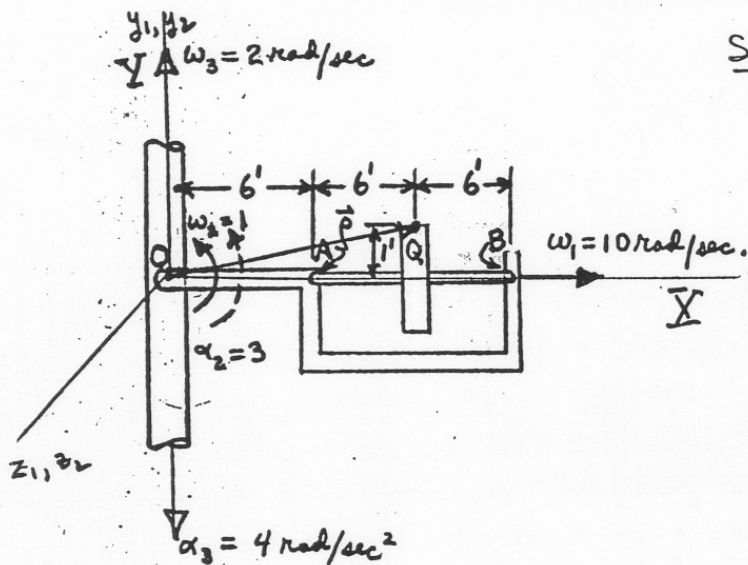

Solution

① Let axes  $x_1, y_1, z_1$  be attached and moving with the vertical shaft

$$\therefore \vec{\omega}_{1/x_1z_1} = 2\vec{j}$$

$$\dot{\vec{\omega}}_{1/x_1z_1} = -4\vec{j}$$

② Let axes  $x_2, y_2, z_2$  be attached to the horizontal arm so that relative to the frame  $x_1, y_1, z_1$ :

$$\vec{\omega}_{2/1} = \vec{k}$$

$$\dot{\vec{\omega}}_{2/1} = 3\vec{k}$$

(A)  $\therefore \vec{v}_Q = \dot{\vec{R}}_{y_0} + \vec{\omega}_{1/x_1z_1} \times \vec{p}_{P/1} + (\dot{\vec{p}}_{P/1})_r$   
 where  $\dot{\vec{R}}_{y_0} = 0$

$$\vec{p}_{P/1} = 12\vec{i} + \vec{j}$$

$$\vec{\omega}_1 \times \vec{p}_{P/1} = -24\vec{k}$$

$$(\dot{\vec{p}}_{P/1})_r = \dot{\vec{R}}_{z_1} + \vec{\omega}_{2/1} \times \vec{p}_{P/2} + (\dot{\vec{p}}_{P/2})_r = -\vec{i} + 12\vec{j} + 10\vec{k}$$

where  $\dot{\vec{R}}_{z_1} = 0$

$$\vec{p}_{P/2} = \vec{p}_{P/1} = 12\vec{i} + \vec{j}$$

$$\vec{\omega}_{2/1} \times \vec{p}_{P/2} = +12\vec{j} - \vec{i}$$

$$(\dot{\vec{p}}_{P/2})_r = 10\vec{k}$$

$$\therefore \vec{v}_Q = -\vec{i} + 12\vec{j} - 14\vec{k}$$

Let  $\vec{\omega}_{1/x1z} = \vec{\omega}_{1/0}$  ;  $\dot{\vec{\omega}}_{1/x1z} = \dot{\vec{\omega}}_{1/0}$  to simplify notation.

$$\textcircled{B} \vec{a}_Q = \ddot{\vec{R}}_{1/0} + \vec{\omega}_{1/0} \times (\vec{\omega}_{1/0} \times \vec{r}_{P1}) + \dot{\vec{\omega}}_{1/0} \times \vec{r}_{P1} + (\ddot{\vec{r}}_{P1})_r + 2\vec{\omega}_{1/0} \times (\dot{\vec{r}}_{P1})_r$$

where  $\ddot{\vec{R}}_{1/0} = 0$

$$\vec{\omega}_{1/0} \times (\vec{\omega}_{1/0} \times \vec{r}_{P1}) = -48\vec{i}$$

$$\dot{\vec{\omega}}_{1/0} \times \vec{r}_{P1} = +40\vec{k}$$

$$2\vec{\omega}_{1/0} \times \dot{\vec{r}}_{P1} = 2(2\vec{j}) \times (-\vec{i} + 12\vec{j} + 10\vec{k}) = 4\vec{k} + 40\vec{i}$$

$$(\ddot{\vec{r}}_{P1})_r = \ddot{\vec{R}}_{2/1} + (\ddot{\vec{r}}_{P2})_r + \vec{\omega}_{2/1} \times (\vec{\omega}_{2/1} \times \vec{r}_{P2}) + \dot{\vec{\omega}}_{2/1} \times \vec{r}_{P2} + 2\vec{\omega}_{2/1} \times (\dot{\vec{r}}_{P2})_r$$

where:  $\ddot{\vec{R}}_{2/1} = 0$

$$\vec{\omega}_{2/1} \times (\vec{\omega}_{2/1} \times \vec{r}_{P2}) = -12\vec{i} - \vec{j}$$

$$\dot{\vec{\omega}}_{2/1} \times \vec{r}_{P2} = 36\vec{j} - 3\vec{i}$$

$$(\ddot{\vec{r}}_{P2})_r = -100\vec{j}$$

$$2\vec{\omega}_{2/1} \times (\dot{\vec{r}}_{P2})_r = 2(3\vec{k}) \times (10\vec{k}) = 0$$

$$= -15\vec{i} - 65\vec{j}$$

$$\therefore \vec{a}_Q = -23\vec{i} - 65\vec{j} + 52\vec{k}$$

## 4.7 HW 6

### 4.7.1 problem 1

#### EM 542 - Homework

##### Problem (18a)

A projectile is fired vertically upward with an initial velocity  $v_o$  at a latitude  $\theta$ . Determine where it lands (i.e. where it crosses the xy plane immediately before striking).

### 4.7.2 problem 2

#### EMA 542

##### Home Work to be Handed In

- 6) A projectile is fired at latitude  $\lambda$  with an initial velocity vector  $v_o = y_o \vec{j} + z_o \vec{k}$  and  $x_o = y_o = z_o = \dot{x}_o = 0$ . It is desired to fire the projectile at an angle  $\alpha = \tan^{-1}(z_o/y_o)$  so that it again crosses the same meridian plane just before it strikes the Earth (i.e., when  $z = 0.0$ ).
- Determine the required firing angle  $\alpha$  in terms of the latitude  $\lambda$ .
  - For  $y_o = 2,000$  ft/sec, and a latitude of  $40^\circ$ , make a 3-D computer plot of the projectile's complete trajectory as seen by an observer on the Earth.

4.7.3 my solution

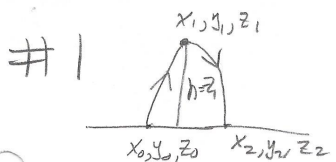

97/100

let  $x_0, y_0, z_0$  be the point fired from. let  $x_1, y_1, z_1$  be the point it reaches max height. let  $x_2, y_2, z_2$  be final point.  
 $z_0 = 0, z_2 = 0$ . first we need to determine time to reach  $z_1$ . from eq. 1.85,

$$z = -g \frac{t^2}{2} + \dot{z}_0 t + \omega_e \dot{x}_0 t^2 \cos(\theta)$$

but  $\dot{x}_0 = 0$  so  $z = -g \frac{t^2}{2} + \dot{z}_0 t \Rightarrow \boxed{z = -g \frac{t^2}{2} + \dot{z}_0 t}$

so  $\dot{z}(t) = -gt + \dot{z}_0$ . when it reaches top,  $\dot{z} = 0$ . here

time to reach top before falling back

we solve for t.

$t = \frac{2\dot{z}_0}{g}$  now we solve for  $z_1, y_1, x_1$ .

$$z_1 = -g \frac{t^2}{2} + \dot{z}_0 t + \omega_e \dot{x}_0 t^2 \cos(\theta) + z_0$$

$$z_1 = -\frac{g}{2} \left(\frac{2\dot{z}_0}{g}\right)^2 + \dot{z}_0 \left(\frac{2\dot{z}_0}{g}\right) + z_0 \Rightarrow \boxed{z_1 = \frac{-2\dot{z}_0^2}{2g} + \frac{2\dot{z}_0^2}{g} + z_0}$$

$$\boxed{z_1 = \frac{1}{2} \frac{2\dot{z}_0^2}{g} + z_0}$$

$$y_1 = -\omega_e t^2 \dot{x}_0 \sin(\theta) + \dot{y}_0 t + y_0$$

so  $y_1 = y_0$

$$x_1 = \frac{\omega_e g t^3}{3} \cos(\theta) + \omega_e t^2 \left( \dot{y}_0 \sin(\theta) - \dot{z}_0 \cos(\theta) \right) + \dot{x}_0 t + x_0$$

$$= \frac{\omega_e g}{3} \left(\frac{2\dot{z}_0}{g}\right)^3 \cos(\theta) + \omega_e \left(\frac{2\dot{z}_0}{g}\right)^2 \left( -\dot{z}_0 \cos(\theta) \right) + x_0$$

$$= \frac{\omega_e}{3} \frac{\dot{z}_0^3}{g^2} \cos(\theta) - \omega_e \frac{\dot{z}_0^3}{g} \cos(\theta) + x_0$$

$$= \boxed{-\frac{4}{3} \frac{\omega_e \dot{z}_0^3}{g} \cos(\theta) + x_0}$$

this the point where it lands

we now need to find  $(x_2, y_2, z_2) \rightarrow x_0 = y_0 = z_0 = 0$   
 $\dot{x}_0, \dot{y}_0 = 0$

to find  $x_2, y_2, z_2$  we need to first find the time it takes to reach the ground; but first need to find initial conditions. i.e. need to find  $\dot{x}_1, \dot{y}_1, \dot{z}_1$  to use as initial conditions at top.

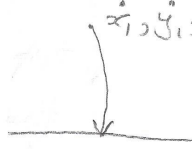

from eq. 1.85.

$\dot{z}_1 = 0$ . (since it stops at top).

$$\dot{x}_1 = \omega_c g t^2 \cos \theta + \omega_c 2t (\dot{y}_0 \sin(\theta) - \dot{z}_0 \cos(\theta)) + \dot{x}_0 = 0$$

$$= \omega_c g \left(\frac{v_0}{g}\right)^2 \cos \theta + \omega_c 2 \left(\frac{v_0}{g}\right) (-v_0 \cos \theta)$$

$$= \omega_c \frac{v_0^2}{g} \cos \theta - 2 \omega_c \frac{v_0^2}{g} \cos \theta = -\omega_c \frac{v_0^2}{g} \cos \theta$$

just need to find posn.

$$\dot{y}_1 = 0.$$

this is  $\dot{z}$  velocity when at top.

so now we know initial conditions. we can find  $\{x_1, y_1\}$ : first need to find how long it takes to fall down.

from (1.85) (c):

$$z_f = -\frac{gt^2}{2} + \dot{z}_1 t + z_1 + \omega_c \dot{x}_1 t^2 \cos \theta$$

at  $z_f = z_0$  since it fall down. so

$$z_0 = -\frac{gt^2}{2} + \left(\frac{1}{2} \frac{v_0}{g} + z_0\right) + \omega_c \left(-\omega_c \frac{v_0^2}{g} \cos \theta\right) t^2 \cos \theta$$

$$\text{so } 0 = -\frac{gt^2}{2} + \frac{1}{2} \frac{v_0}{g} - \omega_c^2 \frac{v_0^2}{g} t^2 \cos^2 \theta$$

$$0 = t^2 \left(-\frac{g}{2} - \omega_c^2 \frac{v_0^2}{g} \cos^2 \theta\right) + \frac{1}{2} \frac{v_0}{g} \Rightarrow t^2 \left(\frac{g}{2} + \omega_c^2 \frac{v_0^2}{g} \cos^2 \theta\right) = \frac{1}{2} \frac{v_0}{g}$$

$$\text{so } t^2 = \frac{1}{2} \frac{v_0}{g} \left(\frac{2g}{g^2 + 2\omega_c^2 v_0^2 \cos^2 \theta}\right) = \frac{v_0}{g^2 + 2\omega_c^2 v_0^2 \cos^2 \theta}$$

$$\text{so } t = \sqrt{\frac{v_0}{g^2 + 2\omega_c^2 v_0^2 \cos^2 \theta}}$$

time to fall to ground again from top.

so now we know the time it takes to fall .

③

we can find  $x_2, y_2$

$$y_2 = -w_e t^2 z_1 \sin \theta + \overset{=0}{y_1'} t + \overset{=y_0}{y_1}$$

$$y_2 = -w_e \left( \frac{v_0}{g + 2w_e^2 v_0^2 \cos^2 \theta} \right) \left( -w_e \frac{v_0^2 \cos \theta}{g} \right) \sin \theta + y_0$$

$$y_2 = \frac{w_e^2 v_0^3 \cos \theta \sin \theta}{g^3 + 2w_e^2 g v_0^2 \cos^2 \theta} + y_0$$

$$x_2 = \frac{w_e g t^3}{3} \cos \theta + w_e t^2 \left( \overset{=0}{y_1'} \sin \theta - \overset{=0}{z_1'} \cos \theta \right) + \overset{=0}{x_1'} t + x_1$$

$$x_2 = \frac{w_e g}{3} \left( \frac{v_0}{g^2 + 2w_e^2 v_0^2 \cos^2 \theta} \right)^{3/2} \cos \theta - w_e \frac{v_0^2}{g} \cos \theta - \frac{2}{3} w_e \frac{v_0^3}{g} \cos \theta + x_0$$

$$= \frac{w_e g}{3} \left( \frac{v_0}{g^2 + 2w_e^2 v_0^2 \cos^2 \theta} \right)^{3/2} \cos \theta - \frac{w_e v_0^2}{g} \cos \theta \left( \frac{v_0}{g^2 + 2w_e^2 v_0^2 \cos^2 \theta} \right)^{1/2} -$$

so, when  $z_0, y_0, x_0 = 0$ , then final answer is

$$y_2 = \frac{w_e^2 v_0^3 \cos \theta \sin \theta}{g^3 + 2w_e^2 g v_0^2 \cos^2 \theta}$$

$$x_2 = \frac{w_e g \cos \theta}{3} \left( \frac{v_0}{g^2 + 2w_e^2 v_0^2 \cos^2 \theta} \right)^{3/2} - \frac{w_e v_0^2 \cos \theta}{g} \sqrt{\frac{v_0}{g^2 + 2w_e^2 v_0^2 \cos^2 \theta}} - \frac{2}{3} \frac{w_e v_0^3 \cos \theta}{g}$$

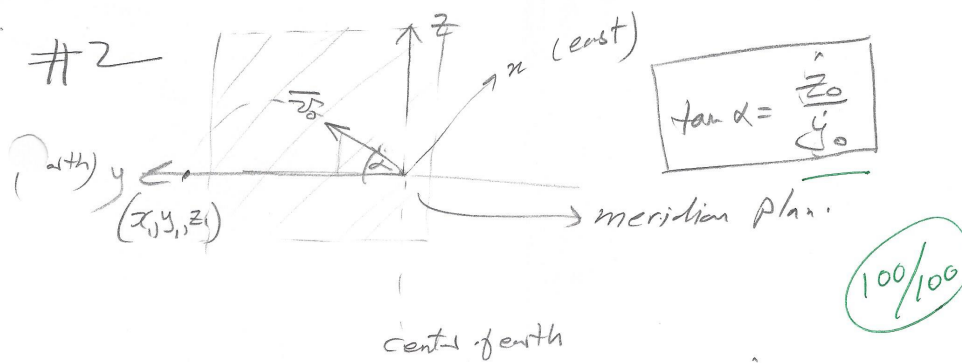

centrif. earth

$$\vec{v}_0 = \dot{y}_0 \hat{j} + \dot{z}_0 \hat{k} \quad \alpha = \tan^{-1} \left( \frac{\dot{z}_0}{\dot{y}_0} \right)$$

So we need it to fall down, s.t.  $x_1 = 0$ . so that it remains in the same meridian plane.

so we need to find  $\alpha$  s.t.  $x_1 = 0$ .

time of flight:  $\dot{z} = -gt + \dot{z}_0 \Rightarrow \dot{z} = 0 = -gt + \dot{z}_0$

here  $t = \frac{\dot{z}_0}{g}$  so time of flight =  $\frac{2\dot{z}_0}{g}$

now  $x_1 = 0$  since projectile falls back to ground.

we want  $x_1 = 0$ . here from eq. 1.85

$$x_1 = 0 = \frac{\omega_0 g}{3} t^3 \cos \lambda + \omega_0 t^2 (\dot{y}_0 \sin \lambda - \dot{z}_0 \cos \lambda) + \dot{y}_0 t + x_0$$

so  $0 = gt \cos \lambda + 3(\dot{y}_0 \sin \lambda - \dot{z}_0 \cos \lambda)$

$$0 = g \left( \frac{2\dot{z}_0}{g} \right) \cos \lambda + 3\dot{y}_0 \sin \lambda - 3\dot{z}_0 \cos \lambda$$

~~$$0 = 2 \frac{\dot{z}_0}{g} \cos \lambda + 3 \sin \lambda - 3 \frac{\dot{z}_0}{g} \cos \lambda$$~~

~~$$0 = \frac{\dot{z}_0}{g} (2 \cos \lambda - 3 \sin \lambda) + 3 \sin \lambda$$~~

~~$$\frac{\dot{z}_0}{g} = \frac{-3 \sin \lambda}{(2 \cos \lambda - 3 \sin \lambda)} \Rightarrow \alpha = \tan^{-1} \left( \frac{-3 \sin \lambda}{2 \cos \lambda - 3 \sin \lambda} \right)$$~~

hand



$$0 = 2\dot{z}_0 \cos \lambda + 3\dot{y} \sin \lambda - 3\dot{z}_0 \cos \lambda.$$

$$\dot{z}_0 = 3\dot{y} \tan \lambda$$

$$\text{so } \tan \alpha = \frac{\dot{z}_0}{\dot{y}_0} = \frac{3\dot{y}_0 \tan \lambda}{\dot{y}_0} = 3 \tan \lambda = 2.5173.$$

$$\text{so } \alpha = 68.3^\circ$$

$$\text{and } \dot{z}_0 = 3(2000) \tan \lambda = 5,037.59 \text{ ft/sec.}$$

3D plot attached.

```
in[21]:= ListPointPlot3D[points, AxesLabel -> {"x", "y", "z"}]
```

Out[21]=

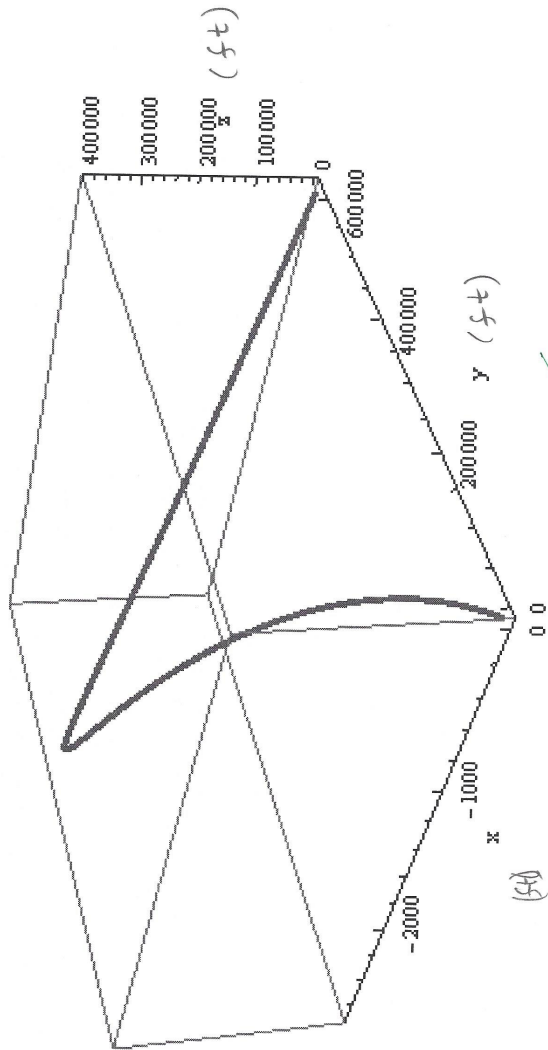

**4.7.4 key solution****EM 542 - Homework****Problem (18a)**

A projectile is fired vertically upward with an initial velocity  $v_o$  at a latitude  $\theta$ . Determine where it lands (i.e. where it crosses the  $xy$  plane immediately before striking).

Homeworks

(18-a)

Example A projectile is fired vertically upward with an initial velocity  $v_0$  at a latitude  $\theta$ . Determine where it lands (i.e. where it crosses the  $xy$  plane immediately before striking)

Solution

Referring to Eqs. (1-85):

$$\begin{cases} x_0 = 0 & ; & \dot{x}_0 = 0 \\ y_0 = 0 & ; & \dot{y}_0 = 0 \\ z_0 = 0 & ; & \dot{z}_0 = v_0 \end{cases}$$

$$\begin{cases} x = \frac{\omega g t^3}{3} \cos \theta - \omega t^2 v_0 \cos \theta \\ \quad \quad \quad = \omega t^2 \cos \theta \left( \frac{gt}{3} - v_0 \right) \\ y = 0 \\ z = -\frac{1}{2} g t^2 + v_0 t \end{cases}$$

Upon crossing the  $xy$  plane,  $z = 0 = -\frac{1}{2} g t^2 + v_0 t$

$$\therefore 0 = t \left( v_0 - \frac{1}{2} g t \right)$$

$$\therefore t = 0, \frac{2v_0}{g}$$

Therefore,  $x = \omega \frac{4v_0^2}{g^2} \cos \theta \left[ \frac{2v_0}{3} - v_0 \right]$

$$\approx x = -\frac{4}{3} \frac{\omega v_0^3 \cos \theta}{g^2} \quad (\because \text{Drift is westerly})$$

\* Example for  $v_0 = 1000 \text{ ft/sec}$ ,  $\theta = 0$ , ;  $x \approx -94 \text{ ft}$  (westerly)

## EMA 542

## Home Work to be Handed In

- 6) A projectile is fired at latitude  $\lambda$  with an initial velocity vector  $v_o = \dot{y}_o \vec{j} + \dot{z}_o \vec{k}$  and  $x_o = y_o = z_o = \dot{x}_o = 0$ . It is desired to fire the projectile at an angle  $\alpha = \tan^{-1}(\dot{z}_o / \dot{y}_o)$  so that it again crosses the same meridian plane just before it strikes the Earth (i.e., when  $z = 0.0$ ).
- Determine the required firing angle  $\alpha$  in terms of the latitude  $\lambda$ .
  - For  $\dot{y}_o = 2,000$  ft/sec, and a latitude of  $40^\circ$ , make a 3-D computer plot of the projectile's complete trajectory as seen by an observer on the Earth.

Prob. #18 cont'd<sup>1</sup>...

10/19/91

(b) A projectile is fired at latitude  $\lambda$  with  $v_0 = \dot{y}_0 \hat{j} + \dot{z}_0 \hat{k}$  with  $x_0 = y_0 = z_0 = \dot{x}_0 = 0$ . It is desired to fire the projectile at an angle  $\alpha = \tan^{-1}(\frac{\dot{z}_0}{\dot{y}_0})$  so it crosses the same meridian plane just before striking the earth.

using eqn's 1-85...

$$x = \frac{\omega e g t^3 \cos \lambda}{3} + \omega e t^2 (\dot{y}_0 \sin \lambda - \dot{z}_0 \cos \lambda)$$

$$y = \dot{y}_0 t$$

$$z = -\frac{g t^2}{2} + \dot{z}_0 t$$

when it crosses the same meridian plane ( $x = x_0$ )  
 $z = z_0 = 0 = -\frac{g t^2}{2} + \dot{z}_0 t$  (when it crosses xy plane)

$$\therefore t = \frac{2 \dot{z}_0}{g}$$

$$y = \dot{y}_0 \left( \frac{2 \dot{z}_0}{g} \right) = \frac{2 \dot{y}_0 \dot{z}_0}{g}$$

$$\begin{aligned} x &= \frac{\omega e g \left( \frac{8 \dot{z}_0^3}{g^3} \right) \cos \lambda}{3} + \omega e \left( \frac{4 \dot{z}_0^2}{g^2} \right) (\dot{y}_0 \sin \lambda - \dot{z}_0 \cos \lambda) \\ &= \frac{8 \omega e \dot{z}_0^3 \cos \lambda}{3 g^2} + \frac{4 \omega e \dot{z}_0^2 \dot{y}_0 \sin \lambda}{g^2} - \frac{4 \omega e \dot{z}_0^3 \cos \lambda}{g^2} \end{aligned}$$

Prob 18 cont'd<sup>2</sup>

10/19/91

$$x = -\frac{4}{3} \frac{w_0 z_0^3 \cos \lambda}{g^2} + \frac{4 w_0 z_0^2 y_0 \sin \lambda}{g^2} = 0$$

$$+\frac{z_0^3 \cos \lambda}{3} = \frac{z_0^2 y_0 \sin \lambda}{1}$$

$$\frac{z_0 \cos \lambda}{3} = y_0 \sin \lambda$$

$$\frac{z_0}{y_0} = \frac{(\sin \lambda) 3}{(\cos \lambda)} = 3 \tan \lambda$$

$$\therefore \alpha = \tan^{-1} z_0 / y_0$$

$$\alpha = \tan^{-1} (3 \tan \lambda)$$

$$\therefore \tan \alpha = 3 \tan \lambda$$

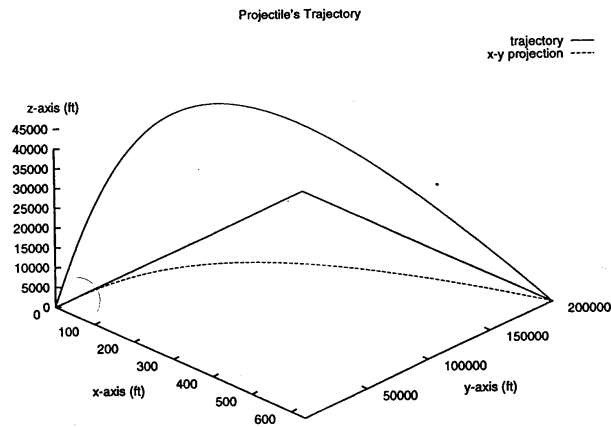

Figure 1: Particle Trajectory  $y_{vel} = 2000\text{ft/sec}$ ,  $z_{vel} = 1610\text{ft/sec}$

If we want the particle to hit on the same meridian plane and it is going to be fired from  $\lambda = 40^\circ$ , then we have to fire the projectile at an angle of  $\alpha = \tan^{-1}(3\tan(\lambda))$ . If we have a  $y$  velocity of  $2000\text{ft/sec}$  then we need to have a  $z$  velocity of  $5034\text{ft/sec}$ . The following figure depicts this scenario.

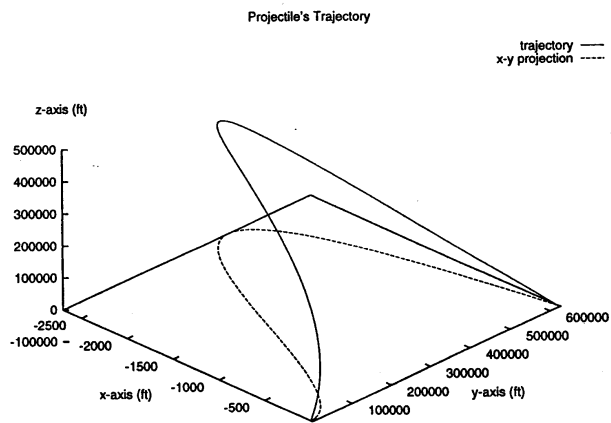

Figure 2: Particle Trajectory  $y_{vel} = 2000\text{ft/sec}$ ,  $z_{vel} = 5034\text{ft/sec}$



## 4.8 HW 7

## 4.8.1 Problem 1

22b

A marble represented by the particle of mass  $m$  is constrained to move along a frictionless groove cut in a circular rotating platform of outer radius  $R$ . The platform rotates about a vertical axis at a constant rate  $\omega$ . Considering that the marble is released at a radius  $b$  with zero velocity relative to the platform,

[a] determine the time for the marble to reach the outer edge of the platform by applying Newton's laws directly

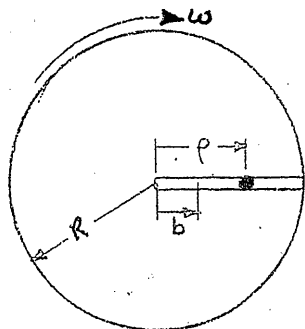
**Solution**

A single rotating coordinates system (body fixed) was used with its origin at the center of disk and rotates with the disk as shown below

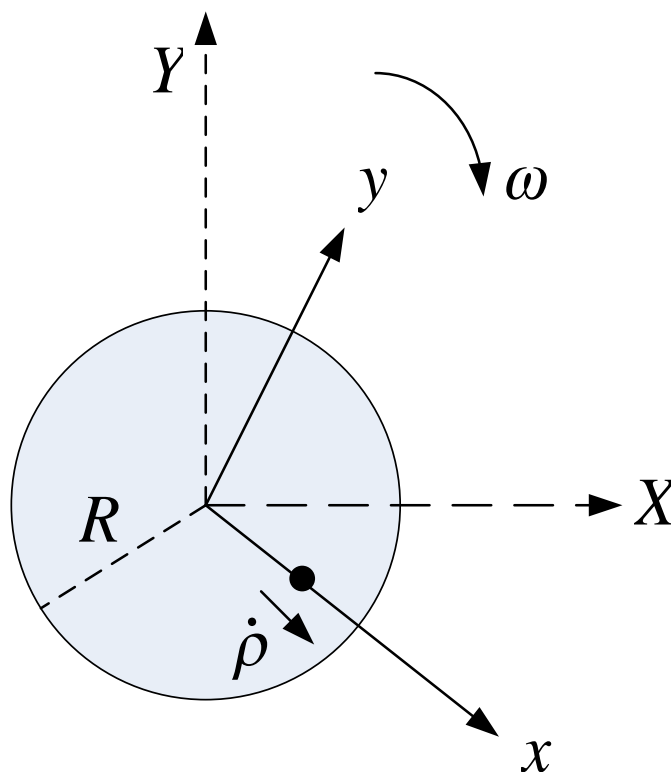

The absolute velocity and absolute acceleration of the particle can now be found as follows

$$\mathbf{v} = \dot{\mathbf{R}} + \dot{\rho}_r + (\boldsymbol{\omega} \times \boldsymbol{\rho})$$

But  $\dot{\mathbf{R}} = 0$  since the center of the C.S. does not move relative to the center of the disk.  $\boldsymbol{\omega} = -\omega \mathbf{k}$ ,  $\boldsymbol{\rho} = \rho \mathbf{i}$  and  $\dot{\rho}_r = \dot{\rho}_r \mathbf{i}$ , therefore

$$\mathbf{v} = \dot{\rho}_r \mathbf{i} + (-\omega \mathbf{k} \times \rho \mathbf{i}) = \dot{\rho}_r \mathbf{i} - \omega \rho \mathbf{j}$$

The absolute acceleration is

$$\begin{aligned} \mathbf{a} &= \ddot{\mathbf{R}} + \ddot{\rho}_r + (\dot{\boldsymbol{\omega}} \times \boldsymbol{\rho}) + \boldsymbol{\omega} \times (\dot{\rho}_r + (\boldsymbol{\omega} \times \boldsymbol{\rho})) \\ &= \ddot{\mathbf{R}} + \ddot{\rho}_r + (\boldsymbol{\omega} \times \dot{\rho}_r) + (\dot{\boldsymbol{\omega}} \times \boldsymbol{\rho}) + (\boldsymbol{\omega} \times \dot{\rho}_r) + \boldsymbol{\omega} \times (\boldsymbol{\omega} \times \boldsymbol{\rho}) \\ &= \ddot{\mathbf{R}} + \ddot{\rho}_r + 2(\boldsymbol{\omega} \times \dot{\rho}_r) + (\dot{\boldsymbol{\omega}} \times \boldsymbol{\rho}) + \boldsymbol{\omega} \times (\boldsymbol{\omega} \times \boldsymbol{\rho}) \end{aligned}$$

But  $\ddot{\mathbf{R}} = 0$ ,  $\boldsymbol{\omega} = -\omega \mathbf{k}$ ,  $\boldsymbol{\rho} = \rho \mathbf{i}$ ,  $\dot{\rho}_r = \dot{\rho}_r \mathbf{i}$ ,  $\ddot{\rho}_r = \ddot{\rho}_r \mathbf{i}$  and  $\dot{\boldsymbol{\omega}} = -\dot{\omega} \mathbf{k} = 0$  since  $\dot{\omega} = 0$ , therefore

$$\begin{aligned} \mathbf{a} &= \ddot{\rho}_r \mathbf{i} + 2(-\omega \mathbf{k} \times \dot{\rho}_r \mathbf{i}) + (-\omega \mathbf{k}) \times (-\omega \mathbf{k} \times \rho \mathbf{i}) \\ &= \ddot{\rho}_r \mathbf{i} - 2\omega \dot{\rho}_r \mathbf{j} + (-\omega \mathbf{k}) \times (-\omega \rho \mathbf{j}) \\ &= -\omega^2 \rho \mathbf{i} + \ddot{\rho}_r \mathbf{i} - 2\omega \dot{\rho}_r \mathbf{j} \\ &= (-\omega^2 \rho + \ddot{\rho}_r) \mathbf{i} - 2\omega \dot{\rho}_r \mathbf{j} \end{aligned}$$

The particular has acceleration in the  $x$  and  $y$  directions. To find how long it takes to travel to the edge, the equation of motion in the  $x$  direction is first found.

Using Newton's first law in the  $x$  direction, the total external forces acting in the  $x$  direction is zero. Hence  $f_x = ma_x$  gives

$$\begin{aligned} m(-\omega^2\rho_r + \ddot{\rho}_r) &= 0 \\ \ddot{\rho}_r - \omega^2\rho_r &= 0 \end{aligned}$$

This is a second order ODE. It is constant coefficients. The roots of the characteristic equation can be used for the solution. The roots are  $\lambda = \frac{-b \pm \sqrt{b^2 - 4ac}}{2a} = \frac{\pm \sqrt{4\omega^2}}{2} = \pm\omega$ , hence the general solution is given by

$$\rho_r = Ae^{\omega t} + Be^{-\omega t}$$

The constants  $A, B$  are found from initial conditions. When  $t = 0$ ,  $\rho_r = b$ , hence

$$b = A + B \tag{1}$$

Taking derivative of the general solution gives

$$\dot{\rho}_r = \omega Ae^{\omega t} - \omega Be^{-\omega t}$$

But when  $t = 0$ ,  $\dot{\rho}_r(0) = 0$  hence

$$\begin{aligned} 0 &= \omega A - \omega B \\ 0 &= A - B \end{aligned} \tag{2}$$

From Eqs (1) and (2) the values of  $A, B$  are found to be

$$A = B = \frac{b}{2}$$

The general solution becomes

$$\begin{aligned} \rho_r(t) &= \frac{b}{2}e^{\omega t} + \frac{b}{2}e^{-\omega t} \\ \rho_r(t) &= b \cosh(\omega t) \end{aligned}$$

Solving for time  $t$  when  $\rho_r(t) = R$  results in

$$\begin{aligned} R &= b \cosh(\omega t) \\ t &= \frac{1}{\omega} \operatorname{arccosh}\left(\frac{R}{b}\right) \end{aligned}$$

Here is a plot showing the time it takes to reach the edge for  $\omega = 1$  rad/sec and  $R = 1$ , as  $b$  is changed from  $10^{-3}$  (very close to the origin) to 1 (the edge). Clearly when  $b = R$  the time is zero, and when  $b = \frac{R}{2}$  the time is found to be  $\operatorname{arccosh}(2) = 1.31$  sec.

```
Plot[ArcCosh[1/x], {x, 10^-3, 1}, GridLines -> Automatic,
GridLinesStyle -> LightGray, Frame -> True,
FrameLabel -> {"t (sec)", None}, {\[Rho],
"Time to reach edge as function of starting position"}},
PlotRange -> All, ImageSize -> 500]
```

The above shows that the time to reach the edge is not linear with the distance, but it is almost linear between 20% and 80% of the distance to the edge.

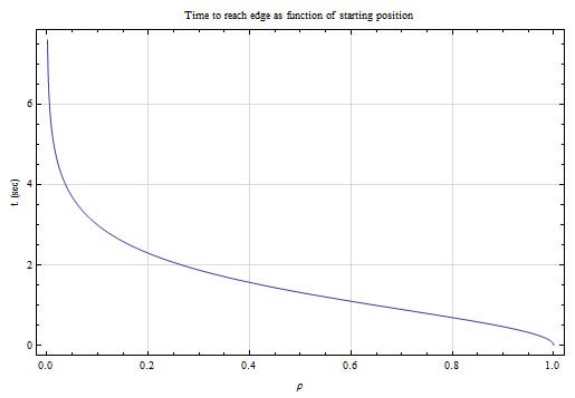

Figure 4.1: Time to reach edge as function of starting point

### 4.8.2 Problem 2

22b

A marble represented by the particle of mass  $m$  is constrained to move along a frictionless groove cut in a circular rotating platform of outer radius  $R$ . The platform rotates about a vertical axis at a constant rate  $\omega$ . Considering that the marble is released at a radius  $b$  with zero velocity relative to the platform,

- [a] determine the time for the marble to reach the outer edge of the platform by applying Newton's laws directly

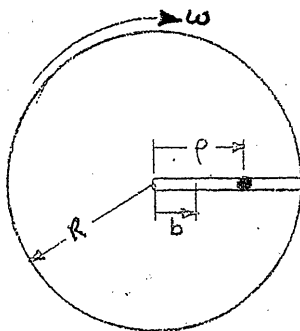

### Solution

The first step is to find the angular velocity vector  $\omega$  of the body C.S. in terms of Euler rates. Using the above diagram the velocity vector  $\omega$  can be written as (Eq. 1.99, page 85, class

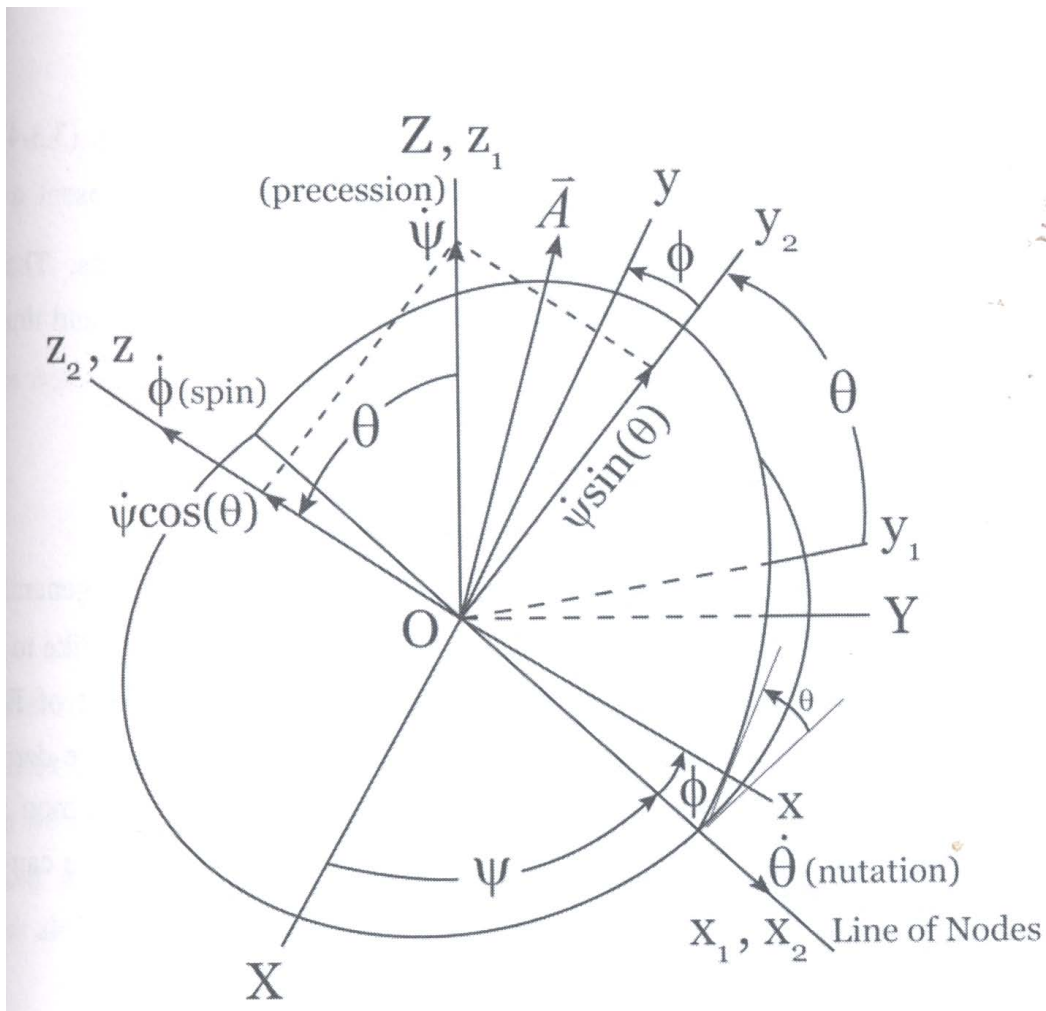

Figure 4.2: Time derivatives Euler Angles. Taken from fig 3.3-4 class notes book for EMA 642, page 79.

notes book).

$$\begin{cases} \omega_x \\ \omega_y \\ \omega_z \end{cases} = \begin{bmatrix} \sin \theta \sin \phi & \cos \phi & 0 \\ \sin \theta \cos \phi & -\sin \phi & 0 \\ \cos \theta & 0 & 1 \end{bmatrix} \begin{cases} \dot{\psi} \\ \dot{\theta} \\ \dot{\phi} \end{cases} \quad (1)$$

Therefore, in vector form the above becomes

$$\omega = \mathbf{i}(\sin \theta \sin \phi \dot{\psi} + \cos \phi \dot{\theta}) + \mathbf{j}(\sin \theta \cos \phi \dot{\psi} - \sin \phi \dot{\theta}) + \mathbf{k}(\cos \theta \dot{\psi} + \dot{\phi}) \quad (2)$$

The position vector of the  $p$  is  $\rho$  given as (in the equation below,  $r$  represents the radius of the satellite, which is shown in the diagram as  $R$ . It was replaced by by small  $r$  so not to confuse this letter with the standard vector  $\mathbf{R}$  that is commonly used in the main equations below).

$$\rho = x\mathbf{i} + (r + \xi)\mathbf{j} + z\mathbf{k}$$

Since  $r$  is constant then the relative velocity of  $p$  is

$$\dot{\rho}_r = \dot{x}\mathbf{i} + \dot{\xi}\mathbf{j} + \dot{z}\mathbf{k}$$

#### 4.8.2.1 part (1)

The absolute velocity of  $P$  is

$$\mathbf{v} = \dot{\mathbf{R}} + \dot{\rho}_r + (\omega \times \rho)$$

$\omega \times \rho$  is now calculated

$$\begin{aligned} \omega \times \rho &= \mathbf{i}(-z \sin \theta \cos \phi \dot{\psi} - z \sin \phi \dot{\theta} - (r + \xi)(\cos \theta \dot{\psi} + \dot{\phi})) \\ &\quad + \mathbf{j}(z \sin \theta \sin \phi \dot{\psi} + z \cos \phi \dot{\theta} + x \cos \theta \dot{\psi} + x \dot{\phi}) \\ &\quad + \mathbf{k}((r + \xi) \sin \theta \sin \phi \dot{\psi} + (r + \xi) \cos \phi \dot{\theta} - x \sin \theta \cos \phi \dot{\psi} + x \sin \phi \dot{\theta}) \end{aligned}$$

Collecting terms, the absolute velocity is simplified to

$$\begin{aligned} \mathbf{v} &= \mathbf{i}(v_X + \dot{x} - z \sin \theta \cos \phi \dot{\psi} - z \sin \phi \dot{\theta} - (r + \xi)(\cos \theta \dot{\psi} + \dot{\phi})) \\ &\quad + \mathbf{j}(v_Y + \dot{x} + z \sin \theta \sin \phi \dot{\psi} + z \cos \phi \dot{\theta} + x \cos \theta \dot{\psi} + x \dot{\phi}) \\ &\quad + \mathbf{k}(v_Z + \dot{z} + (r + \xi) \sin \theta \sin \phi \dot{\psi} + (r + \xi) \cos \phi \dot{\theta} - x \sin \theta \cos \phi \dot{\psi} + x \sin \phi \dot{\theta}) \end{aligned}$$

#### 4.8.2.2 Part (2)

The absolute acceleration of  $P$  is

$$\mathbf{a} = \ddot{\mathbf{R}} + \ddot{\rho}_r + 2(\dot{\omega} \times \rho_r) + (\dot{\omega} \times \rho) + \omega \times (\omega \times \rho) \quad (3)$$

$\ddot{\mathbf{R}}$  is given in the problem as  $(a_X\mathbf{i} + a_Y\mathbf{j} + a_Z\mathbf{k})$  and  $\ddot{\rho}_r = \ddot{x}\mathbf{i} + \ddot{\xi}\mathbf{j} + \ddot{z}\mathbf{k}$ . The remaining term to calculate is  $\dot{\omega}$

Taking derivative w.r.t time of Eq. (2) above results in

$$\begin{aligned}\dot{\omega} &= \mathbf{i} \left( \frac{d}{dt} (\sin \theta \sin \phi \dot{\psi} + \cos \phi \dot{\theta}) \right) + \mathbf{j} \left( \frac{d}{dt} (\sin \theta \cos \phi \dot{\psi} - \sin \phi \dot{\theta}) \right) + \mathbf{k} \left( \frac{d}{dt} (\cos \theta \dot{\psi} + \dot{\phi}) \right) \\ &= \mathbf{i} (\dot{\theta} \dot{\psi} \cos \theta \sin \phi + \dot{\psi} \dot{\phi} \sin \theta \cos \phi + \ddot{\psi} \sin \theta \sin \phi - \dot{\phi} \dot{\theta} \sin \phi + \ddot{\theta} \cos \phi) \\ &\quad + \mathbf{j} (-\ddot{\theta} \sin \phi - \dot{\phi} \dot{\theta} \cos \phi + \ddot{\psi} \sin \theta \cos \phi + \dot{\psi} \dot{\theta} \cos \theta \cos \phi - \dot{\psi} \dot{\phi} \sin \theta \sin \phi) \\ &\quad + \mathbf{k} (\ddot{\psi} \cos \theta - \dot{\psi} \dot{\theta} \sin \theta + \ddot{\phi})\end{aligned}$$

Since the angular accelerations are all constant, all terms above with second time derivatives can be set to zero. Hence  $\dot{\omega}$  simplifies to

$$\begin{aligned}\dot{\omega} &= \mathbf{i} (-\dot{\phi} \dot{\theta} \sin \phi + \dot{\theta} \dot{\psi} \cos \theta \sin \phi + \dot{\psi} \dot{\phi} \sin \theta \cos \phi) \\ &\quad + \mathbf{j} (-\dot{\phi} \dot{\theta} \cos \phi + \dot{\psi} \dot{\theta} \cos \theta \cos \phi - \dot{\psi} \dot{\phi} \sin \theta \sin \phi) \\ &\quad + \mathbf{k} (-\dot{\psi} \dot{\theta} \sin \theta)\end{aligned}$$

Now Eq. (3) can be evaluated. Each term is first evaluated.  $\omega \times \rho$  was found in part (1).  $\omega \times \dot{\rho}_r$  is similar to  $\omega \times \rho$ , but  $\rho$  is changed to  $\dot{\rho}$ . The derivation of  $\omega \times (\omega \times \rho)$  is too complicated to do by hand and was done on the computer. Here is the final result of each component of  $\mathbf{a}$  in as  $\{a_x, a_y, a_z\}$ .

This is the result of evaluating Eq. (3)

$$a_x = a_X + 2\xi \theta' \sin(\theta) \psi' \cos^2(\phi) - \xi (\theta')^2 \sin(\phi) \cos(\phi) - 2 \cos(\theta) \xi' \psi' + \frac{1}{2} \xi \sin^2(\theta) (\psi')^2 \sin(2\phi) - 2\xi' \phi' + 2r\theta' \sin(\theta) \psi'$$

$$a_y = a_Y - 2\xi \theta' \sin(\theta) \psi' \sin(\phi) \cos(\phi) - \xi (\theta')^2 \cos^2(\phi) - \frac{1}{4} \xi \cos(2\theta) (\psi')^2 - 2\xi \cos(\theta) \psi' \phi' + \frac{1}{2} \xi \sin^2(\theta) (\psi')^2 \cos(2\phi) + \xi'$$

$$a_z = a_Z + 2\theta' \xi' \cos(\phi) - 2\xi \theta' \phi' \sin(\phi) + 2 \sin(\theta) \xi' \psi' \sin(\phi) + 2\xi \sin(\theta) \psi' \phi' \cos(\phi) + \frac{1}{2} \xi \sin(2\theta) (\psi')^2 \cos(\phi) - 2r\theta' \phi' \sin(\theta)$$

## 4.8.3 key solution

(1a) The mass center  $C$  of the satellite shown moves with a velocity  $\vec{v}_C = v_x \vec{i} + v_y \vec{j} + v_z \vec{k}$  and an acceleration  $\vec{a}_C = a_x \vec{i} + a_y \vec{j} + a_z \vec{k}$  relative to inertial space denoted by axes  $XYZ$ . The satellite precesses at a constant rate  $\dot{\psi}$  and spins at a constant rate  $\dot{\phi}$  and the angle of nutation  $\theta$  is also constant. An antenna, modeled by a slender rod cantilevered from the satellite along the  $y$  axis of the  $xyz$  set of body axes, is free to vibrate transversely so that each element  $dm$  of the antenna is assumed to move parallel to the  $xz$  body plane. Considering the general position of an element  $P$  at a distance  $\xi$  from the outer perimeter of the satellite to be at the instantaneous location  $(x, \xi, z)$ , determine:

1. the inertial velocity of the elemental mass  $dm$ ;
2. the inertial acceleration of  $dm$ .

Give answers in terms of  $x, y, \xi, \phi, \theta, \psi$  and related time derivatives with your answers given in terms of components along the body axes.

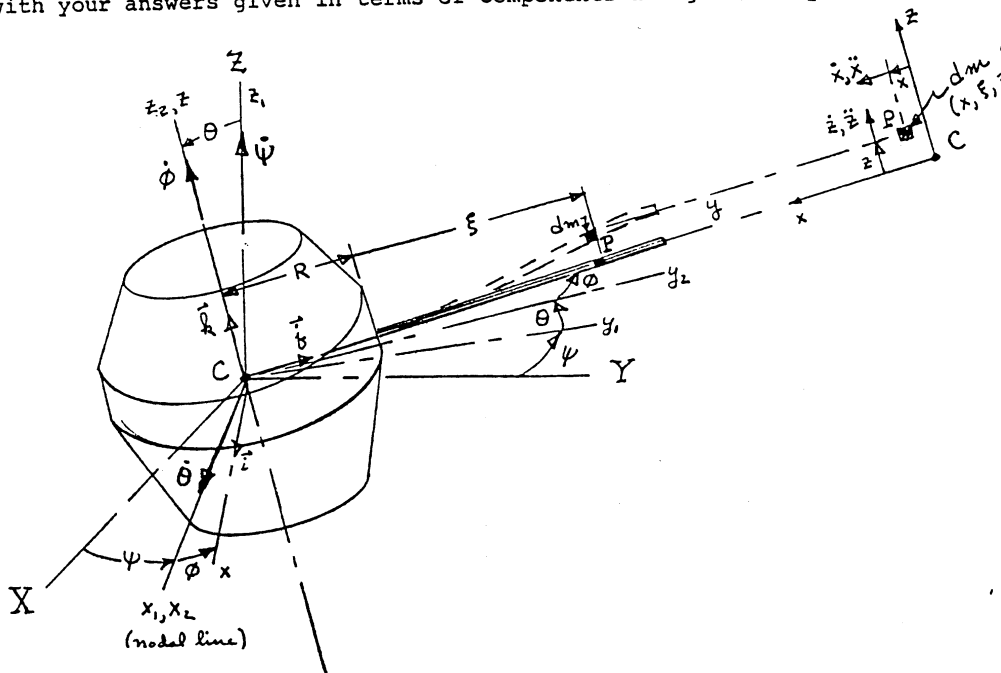





#19 cont'd...

G.H.

RELATIVE PROBLEM:

$$(1) \vec{v}_p = \vec{v}_c + \vec{\omega}_{cs} \times \vec{r}_{P/c} + \dot{\vec{r}}$$

$$\text{where } \vec{v}_c = v_x \vec{i} + v_y \vec{j} + v_z \vec{k}$$

$$\vec{\omega}_{cs} = \omega_x \vec{i} + \omega_y \vec{j} + \omega_z \vec{k} \quad (\text{body axes})$$

$$= \begin{bmatrix} \omega_x \\ \omega_y \\ \omega_z \end{bmatrix} = \begin{bmatrix} \sin\theta \sin\phi & \cos\phi & 0 \\ \sin\theta \cos\phi & -\sin\phi & 0 \\ \cos\theta & 0 & 1 \end{bmatrix} \begin{bmatrix} \dot{\psi} \\ \dot{\phi} \\ \dot{\phi} \end{bmatrix}$$

$$\vec{\omega}_{cs} = (\sin\theta \sin\phi) \dot{\psi} \vec{i} + (\sin\theta \cos\phi) \dot{\psi} \vec{j} + (\dot{\psi} \cos\theta + \dot{\phi}) \vec{k}$$

$$\vec{r}_{P/c} = x \vec{i} + (R + \xi) \vec{j} + z \vec{k}$$

$$\vec{\omega}_{cs} \times \vec{r}_{P/c} = \begin{vmatrix} \vec{i} & \vec{j} & \vec{k} \\ \dot{\psi} \sin\theta \sin\phi & \dot{\psi} \sin\theta \cos\phi & \dot{\psi} \cos\theta + \dot{\phi} \\ x & R + \xi & z \end{vmatrix}$$

$$\vec{\omega}_{cs} \times \vec{r}_{P/c} = \left\{ \dot{\psi} z \sin\theta \cos\phi - (R + \xi)(\dot{\psi} \cos\theta + \dot{\phi}) \right\} \vec{i}$$

$$- \left\{ \dot{\psi} z \sin\theta \sin\phi - x(\dot{\psi} \cos\theta + \dot{\phi}) \right\} \vec{j}$$

$$+ \left\{ (R + \xi) \dot{\psi} \sin\theta \sin\phi - x \dot{\psi} \sin\theta \cos\phi \right\} \vec{k}$$

$$\dot{\vec{r}} = \dot{x} \vec{i} + \dot{z} \vec{k} \quad (\text{dm moves parallel to } xz \text{ body plane})$$

$$\therefore \vec{v}_p = \left( v_x + \dot{x} + \dot{\psi} z \sin\theta \cos\phi - (R + \xi)(\dot{\psi} \cos\theta + \dot{\phi}) \right) \vec{i}$$

$$+ \left( v_y + x(\dot{\psi} \cos\theta + \dot{\phi}) - \dot{\psi} z \sin\theta \sin\phi \right) \vec{j}$$

$$+ \left( v_z + \dot{z} - \dot{\psi} x \sin\theta \cos\phi + (R + \xi) \dot{\psi} \sin\theta \sin\phi \right) \vec{k}$$

#19. cont'd<sup>2</sup>...

G.H.

$$(2) \quad \vec{a}_p = \vec{a}_c + \vec{\omega}_{cs} \times (\vec{\omega}_{cs} \times \vec{r}_{P/C}) + \vec{\omega}_{cs} \times \dot{\vec{r}}_{P/C} + \ddot{\vec{r}}_{P/C} + 2\vec{\omega}_{cs} \times \dot{\vec{r}}_{P/C}$$

where  $\vec{a}_c = a_x \vec{i} + a_y \vec{j} + a_z \vec{k}$

$$\vec{\omega} \times \vec{\omega} \times \vec{r} = \begin{array}{c|ccc} & \vec{i} & \vec{j} & \vec{k} \\ \hline & \psi \sin \theta \sin \phi & \psi \sin \theta \cos \phi & \psi \cos \theta + \dot{\phi} \\ \hline & \psi z \sin \theta \cos \phi - (R+\xi)(\psi \sin \theta \sin \phi) - & x(\psi \cos \theta + \dot{\phi}) - & (R+\xi)(\psi \sin \theta \sin \phi) - \\ & (R+\xi)(\psi \cos \theta + \dot{\phi}) & \psi z \sin \theta \sin \phi & x \psi \sin \theta \cos \phi \end{array}$$

$$\vec{\omega} \times \vec{\omega} \times \vec{r} = \left\{ \begin{array}{l} \psi \sin \theta \cos \phi [(R+\xi)(\psi \sin \theta \sin \phi) - x \psi \sin \theta \cos \phi] - \\ (\psi \cos \theta + \dot{\phi}) [x(\psi \cos \theta + \dot{\phi}) - \psi z \sin \theta \sin \phi] \end{array} \right\} \vec{i}$$

$$- \left\{ \begin{array}{l} \psi \sin \theta \sin \phi [(R+\xi)(\psi \sin \theta \sin \phi) - x \psi \sin \theta \cos \phi] - \\ (\psi \cos \theta + \dot{\phi}) [\psi z \sin \theta \cos \phi - (R+\xi)(\psi \cos \theta + \dot{\phi})] \end{array} \right\} \vec{j}$$

$$+ \left\{ \begin{array}{l} \psi \sin \theta \sin \phi [x(\psi \cos \theta + \dot{\phi}) - \psi z \sin \theta \sin \phi] - \\ \psi \sin \theta \cos \phi [\psi z \sin \theta \cos \phi - (R+\xi)(\psi \cos \theta + \dot{\phi})] \end{array} \right\} \vec{k}$$

$$\vec{\omega}_{cs} = \psi (\sin \theta \cos \phi) \dot{\phi} \vec{i} - \psi (\sin \theta \sin \phi) \dot{\phi} \vec{j} + 0 \vec{k}$$

$$\vec{\omega}_{cs} \times \dot{\vec{r}}_{P/C} = \begin{array}{c|ccc} & \vec{i} & \vec{j} & \vec{k} \\ \hline & \psi \dot{\phi} \sin \theta \cos \phi & -\psi \dot{\phi} \sin \theta \sin \phi & 0 \\ \hline & x & R+\xi & z \end{array}$$

$$= (-\psi \dot{\phi} z \sin \theta \sin \phi) \vec{i} - (\psi \dot{\phi} z \sin \theta \cos \phi) \vec{j} + [(R+\xi)(\psi \dot{\phi} \sin \theta \cos \phi) + \psi \dot{\phi} x \sin \theta \sin \phi] \vec{k}$$

$$\dot{\vec{r}}_{P/C} = \dot{x} \vec{i} + \dot{z} \vec{k}$$

$$2\vec{\omega}_{cs} \times \dot{\vec{r}}_{P/C} = \begin{array}{c|ccc} & \vec{i} & \vec{j} & \vec{k} \\ \hline & 2\psi \dot{\phi} \sin \theta \sin \phi & 2\psi \dot{\phi} \sin \theta \cos \phi & 2(\psi \cos \theta + \dot{\phi}) \\ \hline & \dot{x} & 0 & \dot{z} \end{array}$$

# 19 cont'd.

G.H.

$$2\vec{\omega} \times \vec{r}_{P/C} = (2\dot{\psi}z \sin\theta \cos\phi) \vec{i} - (2\dot{\psi}z \sin\theta \sin\phi - 2\dot{x}(\psi \cos\theta + \phi)) \vec{j} + (-2\dot{\psi}\dot{x} \sin\theta \cos\phi) \vec{k}$$

$$\therefore \vec{a}_P = \left\{ a_x + (R+\xi)(\dot{\psi}^2 \sin^2\theta \sin\phi \cos\phi) - (\dot{\psi}^2 x \sin^2\theta \cos^2\phi) - (x(\psi \cos\theta + \phi)^2 - \dot{\psi}z \sin\theta \sin\phi(\psi \cos\theta + \phi) + \dot{\psi}\dot{x}z \sin\theta \sin\phi + 2\dot{\psi}z \sin\theta \cos\phi + \ddot{x}) \right\} \vec{i}$$

$$+ \left\{ a_y - (R+\xi)(\dot{\psi}^2 \sin^2\theta \sin^2\phi) + \dot{\psi}^2 x \sin^2\theta \sin\phi \cos\phi + \dot{\psi}z \sin\theta \cos\phi(\psi \cos\theta + \phi) - (R+\xi)(\psi \cos\theta + \phi)^2 - \dot{\psi}\dot{x}z \sin\theta \cos\phi - 2\dot{\psi}\dot{z} \sin\theta \sin\phi + 2\dot{x}(\psi \cos\theta + \phi) \right\} \vec{j}$$

$$+ \left\{ a_z + \dot{\psi}x \sin\theta \sin\phi(\psi \cos\theta + \phi) - \dot{\psi}^2 z \sin^2\theta \sin^2\phi - \dot{\psi}^2 \sin^2\theta \cos^2\phi - (R+\xi)(\psi \cos\theta + \phi)\dot{\psi} \sin\theta \cos\phi + (R+\xi)\dot{\psi}\dot{x} \sin\theta \cos\phi + \dot{\psi}\dot{x} \sin\theta \sin\phi - 2\dot{\psi}\dot{x} \sin\theta \cos\phi + \ddot{z} \right\} \vec{k}$$

22b

A marble represented by the particle of mass  $m$  is constrained to move along a frictionless groove cut in a circular rotating platform of outer radius  $R$ . The platform rotates about a vertical axis at a constant rate  $\omega$ . Considering that the marble is released at a radius  $b$  with zero velocity relative to the platform,

- [a] determine the time for the marble to reach the outer edge of the platform by applying Newton's laws directly

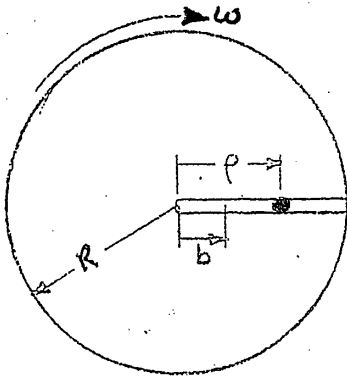

Problem # 22b)

11/12/91 G.#.

A marble represented by the particle of mass  $m$  is constrained to move along a frictionless groove cut in a circular rotating platform of outer radius  $R$ . The platform rotates about a vertical axis at a constant rate  $\omega$ . Considering that the marble is released at a radius  $b$  with zero velocity relative to the platform,

(a) determine the time for the marble to reach the outer edge of the platform by applying Newton's laws directly.

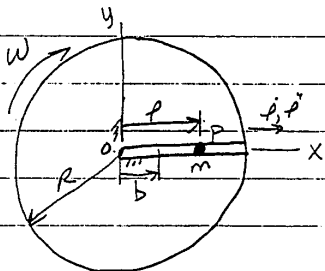

FBD:

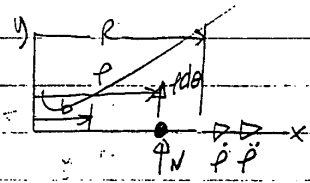

(horizontal plane  $\rightarrow mg=0$ )



$$\vec{v}_p = \vec{v}_0 + \vec{\omega} \times \vec{r} \times \hat{e}_r$$

$$\text{where } \vec{v}_0 = 0$$

$$\vec{\omega} \times \vec{r} = -\omega \hat{k} \times p \hat{i} = -p\omega \hat{j}$$

$$\hat{e}_r = \hat{i}$$

$$\therefore \vec{v}_p = -p\omega \hat{j} + \dot{p} \hat{i}$$

$$\vec{a}_p = \vec{a}_0 + \vec{\omega} \times \vec{\omega} \times \vec{r} + \vec{\omega} \times \dot{\vec{r}} + \ddot{\vec{r}} + 2\vec{\omega} \times \dot{\vec{r}}$$

$$\text{where } \vec{a}_0 = 0$$

$$\vec{\omega} \times \vec{\omega} \times \vec{r} = -\omega \hat{k} \times (-p\omega \hat{j}) = -p\omega^2 \hat{i}$$

$$\vec{\omega} \times \dot{\vec{r}} = 0$$

$$\ddot{\vec{r}} = \ddot{p} \hat{i}$$

$$2\vec{\omega} \times \dot{\vec{r}} = 2\omega \hat{k} \times \dot{p} \hat{i} = 2\omega \dot{p} \hat{j}$$

$$\therefore \vec{a}_p = (\ddot{p} - \omega^2 p) \hat{i} + 2\omega \dot{p} \hat{j}$$

# 226 cont'd ...

11/12/91 B.H.

$$\sum \vec{F} = N \vec{j}$$

$$\therefore N \vec{j} = [(\dot{r} - \omega^2 r) \vec{i} + 2\omega \dot{r} \vec{j}] m$$

equating terms:

$$\left. \begin{array}{l} \dot{r} - \omega^2 r = 0 \\ 2\omega \dot{r} = N/m \end{array} \right\} \therefore \begin{array}{l} \ddot{r} - \omega^2 r = 0 \\ i\vec{N} = 2m\omega \dot{r} \vec{j} \end{array}$$

$$-\ddot{r} = \omega^2 r$$

$$\text{where } \ddot{r} = \frac{d\dot{r}}{dt} = \frac{d\dot{r}}{dr} \frac{dr}{dt} = \frac{d\dot{r}}{dr} \dot{r} = r\omega^2 \quad \text{by chain rule}$$

$$\int \dot{r} d\dot{r} = \int r\omega^2 dr$$

$$\frac{1}{2} \dot{r}^2 = \frac{1}{2} r^2 \omega^2 + C_1$$

$$\text{@ } t=0, \dot{r}=0, r=b \quad (\text{initial conditions})$$

$$\therefore C_1 = -\frac{1}{2} \omega^2 b^2$$

$$\therefore \frac{1}{2} \dot{r}^2 = \frac{1}{2} \omega^2 r^2 - \frac{1}{2} \omega^2 b^2 = \frac{1}{2} \omega^2 (r^2 - b^2)$$

$$\dot{r}^2 = \omega^2 (r^2 - b^2)$$

$$\dot{r} = \omega \sqrt{r^2 - b^2} = \frac{dr}{dt}$$

$$\int_0^t dt = \int_b^R \frac{1}{\omega \sqrt{r^2 - b^2}} dr$$

$$t = \frac{1}{\omega} \left[ \ln \left( r + \sqrt{r^2 - b^2} \right) \right]_b^R$$

$$\therefore t = \frac{1}{\omega} \left[ \ln \left( R + \sqrt{R^2 - b^2} \right) - \ln b \right] = \frac{1}{\omega} \ln \left[ \frac{R + \sqrt{R^2 - b^2}}{b} \right]$$

# 22 b cont'd<sup>2</sup>

11/12/91 Q.H.

(b) Check answers (a) by applying work-energy principle.

$$\int_1^2 \vec{F} \cdot d\vec{r} = \int_{v_1}^{v_2} m v dv \quad \text{or} \quad W_k = \Delta T$$

$$\begin{aligned} dW_k &= \vec{F} \cdot d\vec{s} = \vec{F} \cdot \rho d\theta \quad \text{--- } s = r\theta \\ &= (2\omega \dot{\rho} m \hat{j}) \cdot (\rho d\hat{i} + \rho d\theta \hat{j}) \end{aligned}$$

$$dW_k = 2\omega \dot{\rho} \rho m d\theta = 2m\omega \frac{d\rho}{dt} \rho d\theta$$

$$\text{where } \frac{d\theta}{dt} = \omega \rightarrow d\theta = \omega dt$$

$$\therefore dW_k = 2m\omega \frac{d\rho}{dt} \rho \omega dt = 2m\omega^2 \rho d\rho$$

$$W_k = \int_b^R 2m\omega^2 \rho d\rho = \left. \frac{2m\omega^2 \rho^2}{2} \right|_{\rho=b}^{\rho=R}$$

$$W_k = m\omega^2 (R^2 - b^2)$$

$$\Delta T = T_2 - T_1$$

$$\text{where } v_p = (\rho^2 \omega^2 + \dot{\rho}^2)^{1/2}$$

$$\text{@1, } \dot{\rho} = 0, \rho = b \quad v_{p1} = (b^2 \omega^2)^{1/2} = b\omega$$

$$\text{@2, } \rho = R$$

$$T_2 - T_1 = \frac{1}{2} m v_{p2}^2 - \frac{1}{2} m v_{p1}^2$$

$$= \frac{1}{2} m (R^2 \omega^2 + \dot{\rho}^2) - \frac{1}{2} m (b\omega)^2$$

$$\therefore m\omega^2 (R^2 - b^2) = \frac{1}{2} m [R^2 \omega^2 + \dot{\rho}^2 - (b\omega)^2]$$

$$m\omega^2 R^2 - m\omega^2 b^2 - \frac{1}{2} m\omega^2 R^2 + \frac{1}{2} m\omega^2 b^2 = \frac{1}{2} m \dot{\rho}^2$$



# 22 b cont'd<sup>3</sup>...

||12|a1 R.H.

$$\frac{1}{2} m \omega^2 R^2 - \frac{1}{2} m \omega^2 b^2 = \frac{1}{2} m \dot{r}^2$$

$$m \omega^2 (R^2 - b^2) = m \dot{r}^2$$

$$\omega \sqrt{R^2 - b^2} = \dot{r} = dr/dt$$

$$\int_b^r dt = \int_b^r \frac{dr}{\omega \sqrt{R^2 - b^2}}$$

$$\therefore t = \frac{1}{\omega} \ln \left[ \frac{R + \sqrt{R^2 - b^2}}{b} \right] \quad \text{same result as (a)}$$

SOLUTION TO 22b

$$\vec{a}_p = \ddot{\vec{R}} + \vec{\omega} \times (\vec{\omega} \times \vec{\rho}) + \dot{\vec{\omega}} \times \vec{\rho} + 2\vec{\omega} \times \dot{\vec{\rho}} + \ddot{\vec{\rho}}$$

$$\ddot{\vec{R}} = 0 \quad \vec{\omega} = \omega \vec{k} \quad \vec{\rho} = \rho \vec{i} \quad \dot{\vec{\omega}} = 0$$

$$\vec{\omega} \times (\vec{\omega} \times \vec{\rho}) = -\omega^2 \rho \vec{i} \quad \ddot{\vec{\rho}} = \ddot{\rho}$$

$$2\vec{\omega} \times \dot{\vec{\rho}} = 2\omega \vec{k} \times \dot{\rho} \vec{i} = 2\omega \dot{\rho} \vec{j}$$

$$\Rightarrow \vec{a}_p = (\ddot{\rho} - \omega^2 \rho) \vec{i} + 2\omega \dot{\rho} \vec{j}$$

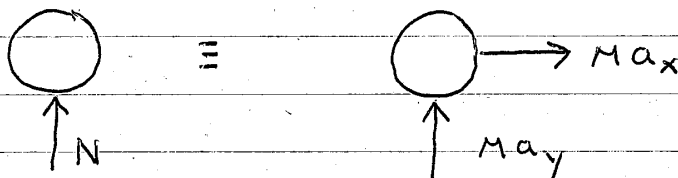

$$\sum F_x \Rightarrow 0 = m(\ddot{\rho} - \omega^2 \rho)$$

$$\Rightarrow \ddot{\rho} - \omega^2 \rho = 0 \quad \rho(0) = b \quad \dot{\rho}(0) = 0$$

$$\text{ASSUME } \rho = A e^{\lambda t} \Rightarrow \lambda^2 - \omega^2 = 0$$

$$\Rightarrow \lambda = \pm \omega \Rightarrow \rho = A e^{\omega t} + B e^{-\omega t}$$

$$\dot{\rho} = A \omega e^{\omega t} - B \omega e^{-\omega t}$$

- 2 -

$$\rho(0) = 0 \Rightarrow \omega(A-B) = 0 \text{ or } A = B \quad (1)$$

$$\rho(0) = b \Rightarrow b = A+B = 2A \quad (2)$$

$$\Rightarrow A = \frac{b}{2}$$

$$\Rightarrow \rho = \frac{b}{2} e^{\omega t} + \frac{b}{2} e^{-\omega t}$$

AT OUTER EDGE  $\rho = R \quad t = T$

$$\Rightarrow R = \frac{b}{2} [e^{\omega T} + e^{-\omega T}]$$

$$= \frac{b}{2} [e^{\theta} + e^{-\theta}] \quad \theta = \omega T$$

$$\Rightarrow \frac{R}{b} = \frac{1}{2} [e^{\theta} + e^{-\theta}] = \cosh \theta$$

$$\Rightarrow \theta = \cosh^{-1} \left( \frac{R}{b} \right) = \ln \left[ \frac{R}{b} + \sqrt{\frac{R^2}{b^2} - 1} \right]$$

$$\Rightarrow T = \frac{1}{\omega} \ln \left[ \frac{R + \sqrt{R^2 - b^2}}{b} \right]$$

## 4.9 HW 8

## 4.9.1 Problem 1

EMA 542  
Home Work to be Handed In

- 6A) A mass is mounted on a rigid weightless rod of length  $l$ . The rod is inclined at an angle  $\alpha$  with respect to the shaft  $AB$  as shown. The shaft spins with a constant angular velocity  $\omega$  and precesses about a fixed vertical axis with constant angular velocity  $N$ . Determine the bearing forces on the shaft at  $A$  and  $B$  due to the prescribed motion. Neglect the effect of gravity.

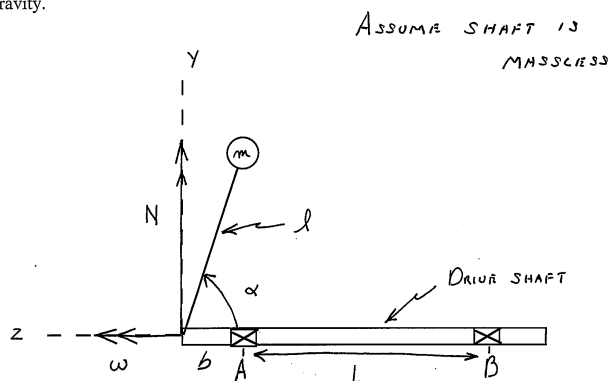

Figure 4.3: Problem description

To find the bearing force on the beam, the vertical force that the mass exerts on the left edge of the beam is first found. This requires finding the acceleration of the mass  $m$  and from that  $F = ma$  is used to find the force. Therefore, the first step is to find the absolute acceleration vector  $a$  of the mass  $m$  treated as a particle.

The direction of the angular acceleration vector  $N$  is fixed in space. Hence the body fixed coordinates system will have its origin at left edge of the shaft, and its  $y$  axis in the same direction as  $Y$  axis of the reference frame (inertial frame in this case). The position vector of  $m$  in body fixed coordinates c.s. is

$$\rho = -l \cos \alpha \mathbf{k} + l \sin \alpha \mathbf{j}$$

Its relative velocity is

$$\dot{\rho}_r = 0$$

Since the mass does not move relative to the c.s. It follows also that

$$\ddot{\rho}_r = 0$$

Now, the angular acceleration of the body fixed c.s. is

$$\omega = \omega \mathbf{K} + N \mathbf{j}$$

Since  $\mathbf{K}$  is aligned with  $\mathbf{k}$  all the time, the above can be written using c.s. basis vectors

$$\boldsymbol{\omega} = \omega \mathbf{k} + N \mathbf{j}$$

This is valid for all time. Now  $\dot{\boldsymbol{\omega}}$  is found. The only angular velocity vector which changes direction is  $\omega \mathbf{k}$ . The angular velocity vector  $N \mathbf{j}$  does not change direction. Therefore

$$\dot{\boldsymbol{\omega}} = \{\dot{\omega} \mathbf{k} + (N \mathbf{j} \times \omega \mathbf{k})\} + \{\dot{N} \mathbf{j} + 0\}$$

Since all angular velocities are zero then  $\dot{\omega} \mathbf{k} = 0$  and  $\dot{N} \mathbf{j} = 0$ . The above becomes

$$\begin{aligned} \dot{\boldsymbol{\omega}} &= N \mathbf{j} \times \omega \mathbf{k} \\ &= N \omega \mathbf{i} \end{aligned}$$

Now all the terms needed have been found, the absolute acceleration vector is determined

$$\begin{aligned} \mathbf{a} &= \ddot{\mathbf{R}} + \ddot{\rho}_r + 2(\boldsymbol{\omega} \times \dot{\rho}_r) + (\dot{\boldsymbol{\omega}} \times \rho) + \boldsymbol{\omega} \times (\boldsymbol{\omega} \times \rho) \\ &= (\dot{\boldsymbol{\omega}} \times \rho) + \boldsymbol{\omega} \times (\boldsymbol{\omega} \times \rho) \\ &= (N \omega \mathbf{i} \times (-l \cos \alpha \mathbf{k} + l \sin \alpha \mathbf{j})) + (\omega \mathbf{k} + N \mathbf{j}) \times ((\omega \mathbf{k} + N \mathbf{j}) \times (-l \cos \alpha \mathbf{k} + l \sin \alpha \mathbf{j})) \\ &= (N \omega l \cos \alpha \mathbf{j} + N \omega l \sin \alpha \mathbf{k}) + (\omega \mathbf{k} + N \mathbf{j}) \times (-\omega l \sin \alpha \mathbf{i} - N l \cos \alpha \mathbf{i}) \\ &= \mathbf{j}(\omega^2 l \sin \alpha - \omega N l \cos \alpha + N \omega l \cos \alpha) + \mathbf{k}(-N \omega l \sin \alpha + N^2 l \cos \alpha + N \omega l \sin \alpha) \\ &= \omega^2 l \sin \alpha \mathbf{j} + N^2 l \cos \alpha \mathbf{k} \end{aligned}$$

Therefore, the downward vertical force on the beam is

$$\begin{aligned} f_y &= m a_y \\ &= m \omega^2 l \sin \alpha \mathbf{j} \end{aligned}$$

And

$$\begin{aligned} f_z &= m a_z \\ &= m N^2 l \cos \alpha \mathbf{k} \end{aligned}$$

Drawing a free body diagram of the beam, the reactions can be found

Taking moments around point  $A$  gives

$$\begin{aligned} |f_y| b + V_B L &= 0 \\ V_B &= -m \omega^2 l \sin \alpha \frac{b}{L} \end{aligned}$$

And taking moments around point  $B$  gives

$$\begin{aligned} |f_y| (b + L) - V_A L &= 0 \\ V_A &= m \omega^2 l \sin \alpha \frac{(b + L)}{L} \end{aligned}$$

Now that  $V_A$  and  $V_B$  (the reactions) are found and the load on the end is also known, the bending moment and shear diagrams can also be found if needed. Internal stress at any section can also be found.

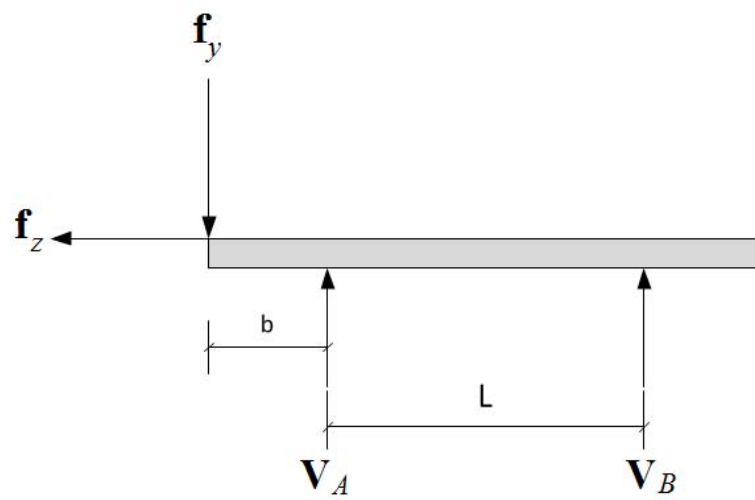

Figure 4.4: Free body diagram for shaft showing all acting loads

## 4.9.2 Problem 2

## EMA 542

## Home Work to be Handed In

- 7) Shown below is a simple model of a oil delivery system. The vertical drive shaft spins with a constant angular velocity  $\omega$ . The oil delivery tube is modeled as a slender flexible beam of length  $L$ , total mass  $m$ , elastic modulus  $E$ , and cross sectional moment of inertia  $I$ . For preliminary design purposes you can neglect the effects of the fluid within the tube.

The oiling system must not strike the side of its housing as it rotates, therefore, your boss asks you to determine the following:

- The steady state moment,  $M_\zeta$ , at a general distance,  $\zeta$ , from point A along the tube.
- The steady state deflection,  $\eta_s$ , at the tip of the tube.

Assume for this design iteration that  $\eta \cos \theta \ll \zeta \sin \theta$

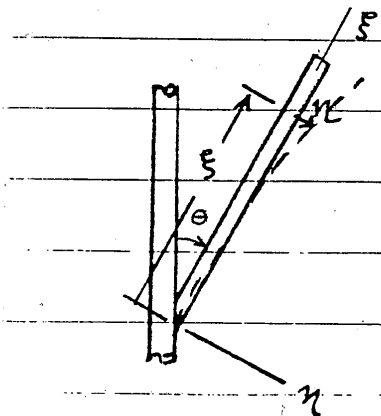

Figure 4.5: Free body diagram for shaft showing all acting loads

The first step is to find the absolute acceleration  $a$  of a unit mass of tube. A body fixed coordinates system is setup which has its origin where the tube is attached to the vertical shaft and attached to the vertical shaft as shown in this diagram

The analysis starts by assuming the oil tube is rigid. Once the forces are found, then the tube is assumed to be elastic in order to find the end deflection. The position vector  $\rho$  of

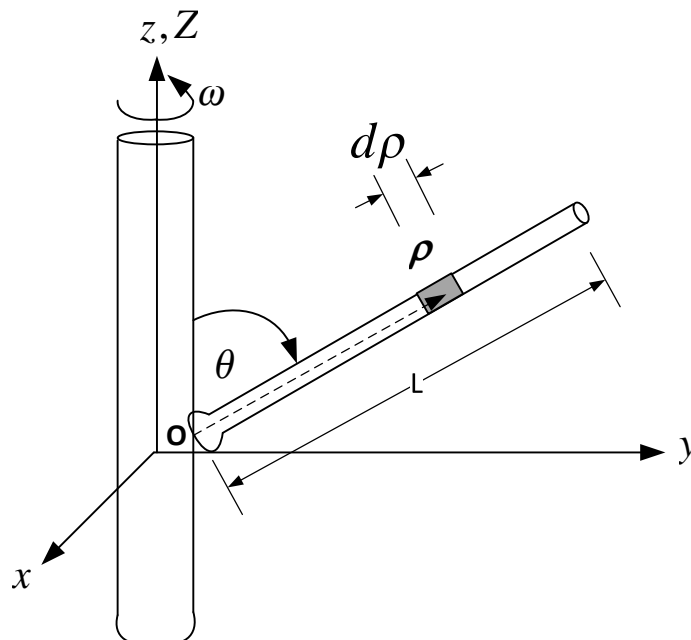

Figure 4.6: Showing body fixed coordinates system

unit mass  $dm$  of length  $d\rho$  is shown above in gray area is

$$\rho = \rho \sin \theta \mathbf{j} + \rho \cos \theta \mathbf{k}$$

And  $\dot{\rho}_r = \ddot{\rho}_r = 0$ . The angular velocity of the body fixed c.s. is

$$\omega = \omega \mathbf{K} = \omega \mathbf{k}$$

Since the angular acceleration  $\dot{\omega}$  is constant, then

$$\dot{\omega} = \dot{\omega} \mathbf{K} = \dot{\omega} \mathbf{k} = 0$$

The absolute acceleration of  $dm$  is given by

$$\mathbf{a} = \ddot{\mathbf{R}} + \ddot{\rho}_r + 2(\dot{\omega} \times \rho_r) + (\dot{\omega} \times \rho) + \omega \times (\omega \times \rho)$$

Since  $\ddot{\mathbf{R}} = 0$  and  $\dot{\omega} = 0$  the above simplifies to

$$\mathbf{a} = \omega \times (\omega \times \rho) \tag{1}$$

Hence

$$\begin{aligned} \omega \times \rho &= \omega \mathbf{k} \times (\rho \sin \theta \mathbf{j} + \rho \cos \theta \mathbf{k}) \\ &= -\omega \rho \sin \theta \mathbf{i} \end{aligned}$$

Therefore

$$\begin{aligned} \omega \times (\omega \times \rho) &= \omega \mathbf{k} \times (-\omega \rho \sin \theta \mathbf{i}) \\ &= -\omega^2 \rho \sin \theta \mathbf{j} \end{aligned}$$

Eq. (1) becomes

$$\mathbf{a} = -\omega^2 \rho \sin \theta \mathbf{j}$$



Since

$$dm = \frac{m}{L}d\rho$$

Then the force acting on  $dm$  due the above acceleration is

$$\begin{aligned} dF &= adm \\ &= -\omega^2 \rho \sin \theta \frac{m}{L} d\rho \mathbf{j} \end{aligned}$$

The force up to some point  $\zeta$  in the tube is found by integration

$$\begin{aligned} F(\zeta) &= - \int_0^\zeta \omega^2 \rho \sin \theta \frac{m}{L} d\rho \mathbf{j} \\ &= -\omega^2 \frac{\zeta^2}{2} \sin \theta \frac{m}{L} \mathbf{j} \end{aligned}$$

The total force is

$$F(L) = -\omega^2 \frac{L}{2} \sin \theta m \mathbf{j}$$

At a section distance  $\zeta$  the forces are shown below

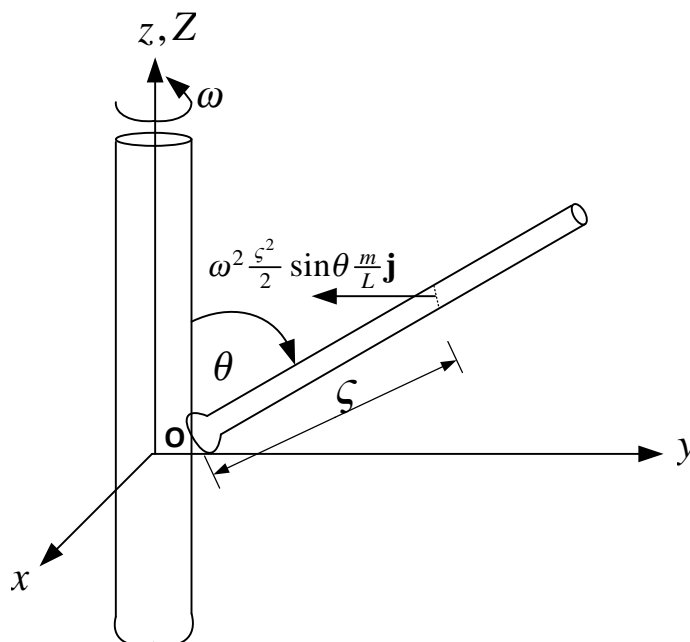

Figure 4.7: Total force acting on tube at a given distance from the shaft

#### 4.9.2.1 Part a

Now that the force vector at a distance along the tube is found, the bending moment at a section distance  $\zeta$  is calculated.

The weight of the tube is  $\frac{m}{L}$  per unit length, which can be modeled as uniform distributed load. A free body diagram of the oil tube is given below. The force in the  $y$  direction is

resolved as axial force and as perpendicular force to the tube.

Resolving  $\omega^2 \frac{L}{2} \sin \theta m j$  along the tube length, and perpendicular to the tube length gives an axial force of  $\omega^2 \frac{\zeta^2}{2} \sin^2 \theta \frac{m}{L}$  and perpendicular force  $\omega^2 \frac{\zeta^2}{2} \sin \theta \frac{m}{L} \cos \theta$  as shown in this diagram. The axial force does not produce bending moment. The weight of tube is  $\frac{m}{L} g$  per unit length and acts in the  $z$  direction. The weight is also resolved so that it acts perpendicular to the tube as well giving  $\frac{m}{L} g \sin \theta$  per unit length. Therefore for distance  $\zeta$  from the origin, the total weight is  $\frac{m}{L} g \zeta \sin \theta$

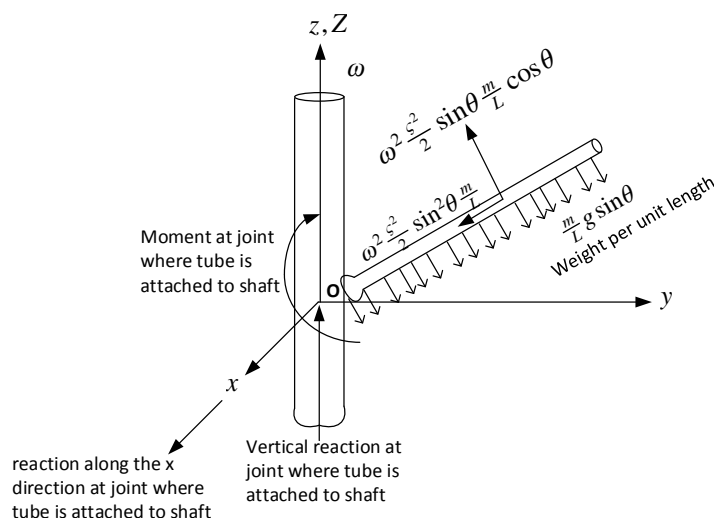

Figure 4.8: Showing all forces acting at section distance  $\zeta$  in the tube

Therefore, the bending moment at section distance  $\zeta$  is

$$\begin{aligned} M(\zeta) &= \left( \omega^2 \frac{\zeta^2}{2} \sin \theta \frac{m}{L} \cos \theta \right) \zeta - \left( \frac{m}{L} g \sin \theta \zeta \right) \frac{\zeta}{2} \\ &= \omega^2 \frac{\zeta^3}{2} \sin \theta \frac{m}{L} \cos \theta - \frac{m}{2L} g \sin \theta \zeta^2 \end{aligned}$$

Unit check: Moment is force times distance. Hence units is  $\frac{ML^2}{T^2}$ . Checking units of each term in the RHS above it agrees.

#### 4.9.2.2 Part b

To find end point deflection, the tube is treated as elastic and viewed as follows

For purpose of finding end point deflection at steady state, only forces acting in the transverse direction to the tube as shown need to be considered. The end force is found by letting  $\zeta = L$  in the above which gives the force at the free end as

$$P = \omega^2 m \frac{L}{2} \sin \theta$$

let  $\beta$  be the weight per unit length. Using cantilever beam end deflection formula the end

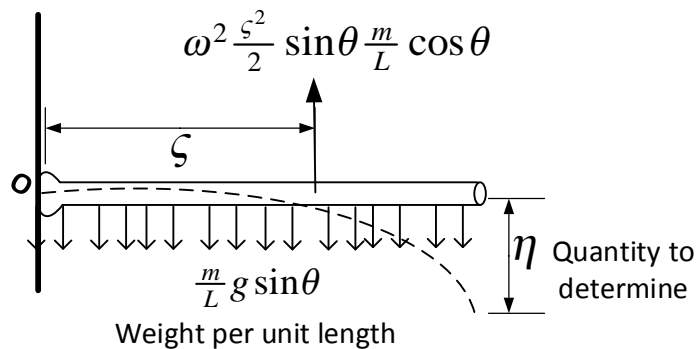

Figure 4.9: Looking at oil tube as a cantilever beam in order to determine end point deflection

deflection is given by

$$\eta = \frac{PL^3}{3EI} - \frac{\beta L^4}{8EI}$$

A positive sign is given to deflection to due to  $P$  since it acts up, and the weight acts down. Hence end point deflection is

$$\begin{aligned} \eta &= \frac{\omega^2 m \frac{L}{2} \sin \theta L^3}{3EI} - \frac{\frac{m}{L} g \sin \theta L^4}{8EI} \\ &= \frac{\omega^2 mL^4 \sin \theta}{6EI} - \frac{mg \sin \theta L^3}{8EI} \\ &= \frac{4\omega^2 mL^4 \sin \theta - 3mg \sin \theta L^3}{24EI} \\ &= \frac{mL^3 \sin \theta (4\omega^2 L - 3g)}{24EI} \end{aligned}$$

## 4.9.3 key solution

EMA 542

## Home Work to be Handed In

- 6A) A mass is mounted on a rigid weightless rod of length  $l$ . The rod is inclined at an angle  $\alpha$  with respect to the shaft  $AB$  as shown. The shaft spins with a constant angular velocity  $\omega$  and precesses about a fixed vertical axis with constant angular velocity  $N$ . Determine the bearing forces on the shaft at  $A$  and  $B$  due to the prescribed motion. Neglect the effect of gravity.

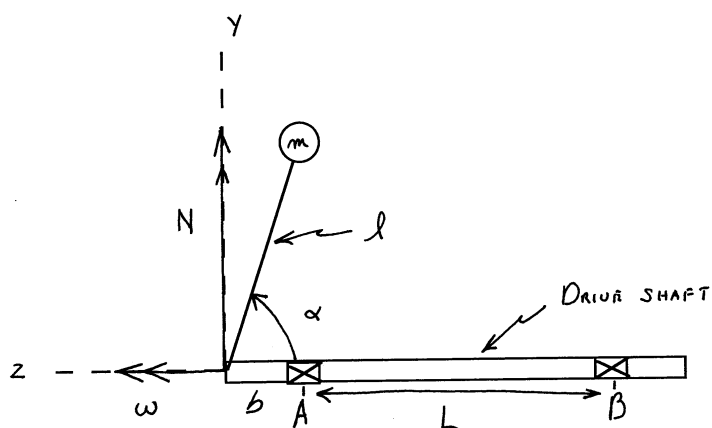

## EMA 542 SOLUTION TO HWK 6A

$\omega = \text{CONST}$      $\alpha = \text{CONST.}$     XYZ ROTATED WITH ANGULAR VELOCITY  $\vec{\omega}_{cs} = N\vec{j}$

$$\vec{a}_p = \vec{a}_0 + \vec{\omega} \times (\vec{\omega} \times \vec{r}) + \dot{\vec{\omega}} \times \vec{r} + 2\vec{\omega} \times \dot{\vec{r}}_r + \ddot{\vec{r}}_r$$

$$\vec{r} = -l \cos \alpha \vec{i} + l \sin \alpha \vec{j} \quad \dot{\vec{r}}_r = -l \sin \alpha \omega \vec{i}$$

$$\ddot{\vec{r}}_r = -l \sin \alpha \omega^2 \vec{j} \quad \vec{\omega} \times \vec{r} = N\vec{j} \times (-l \cos \alpha \vec{i} + l \sin \alpha \vec{j})$$

$$\vec{\omega} \times \dot{\vec{r}} = -N l \cos \alpha \vec{i} \quad \vec{\omega} \times (\vec{\omega} \times \vec{r}) = N\vec{j} \times (-N l \cos \alpha \vec{i})$$

$$\vec{\omega} \times (\vec{\omega} \times \dot{\vec{r}}) = N^2 l \cos \alpha \vec{i} \quad \dot{\vec{\omega}} = 0$$

$$\therefore \vec{\omega} \times \dot{\vec{r}} = 0 \quad 2\vec{\omega} \times \dot{\vec{r}}_r = 2N\vec{j} \times (-l \sin \alpha \omega \vec{i})$$

$$\therefore \underline{2\vec{\omega} \times \dot{\vec{r}}_r} = 2N\omega l \sin \alpha \vec{i}$$

$$\therefore \vec{a} = -l \sin \alpha \omega^2 \vec{j} + (N \cos \alpha + 2\omega \sin \alpha) N l \vec{i}$$

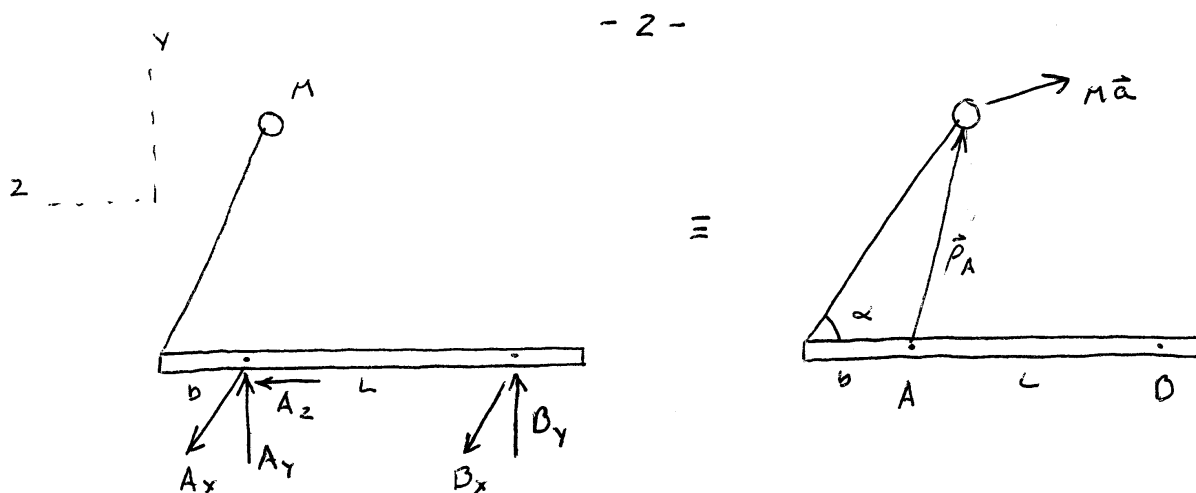

ASSUME ONLY A HAS A THRUST BEARING

$$\sum F_x \Rightarrow A_x + B_x = 0 \quad (1)$$

$$\sum F_y \Rightarrow A_y + B_y = -Ml \sin \alpha \omega^2 \quad (2)$$

$$\sum F_z \Rightarrow A_z = MNl (N \cos \alpha + 2\omega \sin \alpha) \quad (3)$$

$$\sum M_A \Rightarrow$$

$$B_y L \bar{i} - B_x L \bar{j} = \vec{r}_A \times M \vec{a} \quad \vec{r}_A = l \sin \alpha \bar{j} - (l \cos \alpha - b) \bar{k}$$

$$\vec{r}_A \times M \vec{a} = M [ l \sin \alpha \bar{j} - (l \cos \alpha - b) \bar{k} ] \times [ -l \sin \alpha \omega^2 \bar{j} + Nl (N \cos \alpha + 2\omega \sin \alpha) \bar{k} ]$$

$$= MNl^2 \sin \alpha (N \cos \alpha + 2\omega \sin \alpha) \bar{i} - l \sin \alpha \omega^2 (l \cos \alpha - b) \bar{i}$$

- 3 -

$$\Rightarrow \vec{r}_A \times M \vec{a} = M \left[ N^2 l^2 \sin \alpha \cos \alpha + 2N \omega l^2 \sin^2 \alpha - l^2 \omega^2 \sin \alpha \cos \alpha + l b \sin \alpha \omega^2 \right] \vec{i}$$

$$\vec{r}_A \times M \vec{a} = M l \sin \alpha \left[ 2N \omega l \sin \alpha + l (N^2 - \omega^2) \cos \alpha + b \omega^2 \right] \vec{i}$$

$$\Sigma M_{Ax} \Rightarrow B_y L = [\vec{r}_A \times M \vec{a}]_x$$

$$\text{or } B_y = \frac{M l}{L} \sin \alpha \left[ 2N \omega l \sin \alpha + l (N^2 - \omega^2) \cos \alpha + b \omega^2 \right] \quad (4)$$

$$\Sigma M_{Ay} \Rightarrow -B_x L = 0$$

$$\Rightarrow B_x = 0 \quad (5)$$

$$(1) \Rightarrow A_x = 0$$

$$(2) \Rightarrow A_y = -M l \sin \alpha \omega^2 - \frac{M l}{L} \sin \alpha \left[ 2N \omega l \sin \alpha + l (N^2 - \omega^2) \cos \alpha + b \omega^2 \right]$$

$$\therefore A_x = 0$$

$$B_x = 0$$

$$A_y = -\frac{M l}{L} \sin \alpha \left[ 2N \omega l \sin \alpha + l (N^2 - \omega^2) \cos \alpha + (b + L) \omega^2 \right]$$

$$A_z = M N l \left[ N \cos \alpha + 2 \omega \sin \alpha \right]$$

$$D_y = \frac{M l}{L} \sin \alpha \left[ 2N \omega l \sin \alpha + (N^2 - \omega^2) l \cos \alpha + b \omega^2 \right]$$

## EMA 542

## Home Work to be Handed In

- 7) Shown below is a simple model of a oil delivery system. The vertical drive shaft spins with a constant angular velocity  $\omega$ . The oil delivery tube is modeled as a slender flexible beam of length  $L$ , total mass  $m$ , elastic modulus  $E$ , and cross sectional moment of inertia  $I$ . For preliminary design purposes you can neglect the effects of the fluid within the tube.

The oiling system must not strike the side of its housing as it rotates, therefore, your boss asks you to determine the following:

- The steady state moment,  $M_\zeta$ , at a general distance,  $\zeta$ , from point  $A$  along the tube.
- The steady state deflection,  $\eta_s$ , at the tip of the tube.

Assume for this design iteration that  $\eta \cos \theta \ll \zeta \sin \theta$

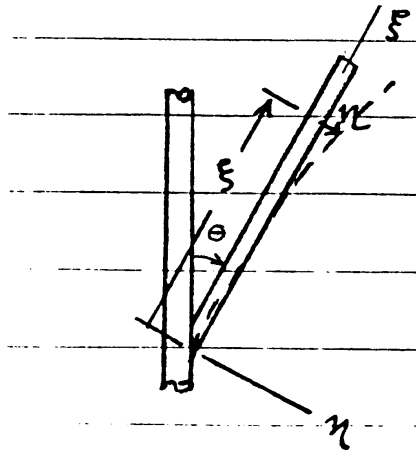



## EMA 542 - SOLUTION HWK 7

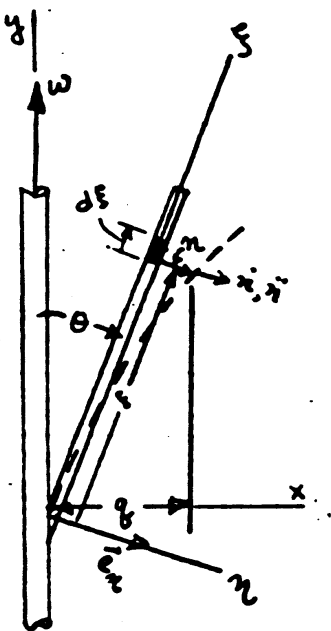

"Steady State" shape of a rotating rod

$$1) \quad \vec{q} = \xi \sin \theta + \eta \cos \theta$$

$$2) \quad d\vec{F} = \vec{a} dm = -g \omega^2 \frac{m}{l} d\xi \vec{i} \quad (\text{dynamic load})$$

$$\stackrel{\omega}{=} d\vec{F} = -\{\xi \sin \theta + \eta \cos \theta\} \omega^2 \frac{m}{l} d\xi \vec{i} \quad (\text{dynamic load})$$

\* It is a reasonably good assumption that  $\eta \cos \theta \ll \xi \sin \theta$

Assume  $\eta \cos \theta \ll \xi \sin \theta$

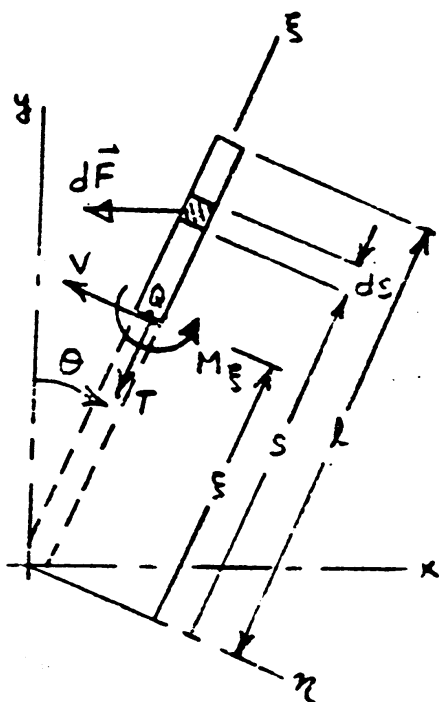

$$d\vec{F} = \vec{a} dm = -(\xi \sin \theta) \omega^2 \frac{m}{l} ds \vec{i}$$

$$\therefore d\vec{M}_Q = |dF| (s - \xi) \cos \theta \vec{k}$$

$$\text{or } d\vec{M}_Q = \frac{m}{l} \omega^2 \sin \theta \cos \theta s (s - \xi) ds \vec{k}$$

$$\therefore \vec{M}_Q = \frac{m}{l} \omega^2 \sin \theta \cos \theta \int_{\xi}^l s (s - \xi) ds \vec{k}$$

$$\stackrel{\omega}{=} \vec{M}_Q = \vec{k} \int_{\xi}^l s (s - \xi) ds$$

- 2 -

$$\text{where } k_1 = \frac{m}{2} \omega^2 \sin \theta \cos \theta$$

$$\begin{aligned} \therefore \vec{M}_Q &= k_1 \left[ \frac{1}{3} (l^3 - \xi^3) - \frac{1}{2} \xi (l^2 - \xi^2) \right] \bar{e}_2 \\ &= k_1 \left[ \frac{1}{3} (l - \xi)^3 + \frac{1}{2} \xi (l - \xi)^2 \right] \bar{e}_2 = (\text{dynamic moment})_Q \end{aligned}$$

NOTE THAT FOR  $\dot{\theta} = 0$ :

$$\vec{M}_Q = \vec{M}_A = \frac{1}{3} \omega^2 M l^2 \sin \theta \cos \theta \bar{e}_2$$

THE DYNAMIC MOMENT FOR THE ENTIRE  
BEAM FROM PREVIOUS ANALYSIS

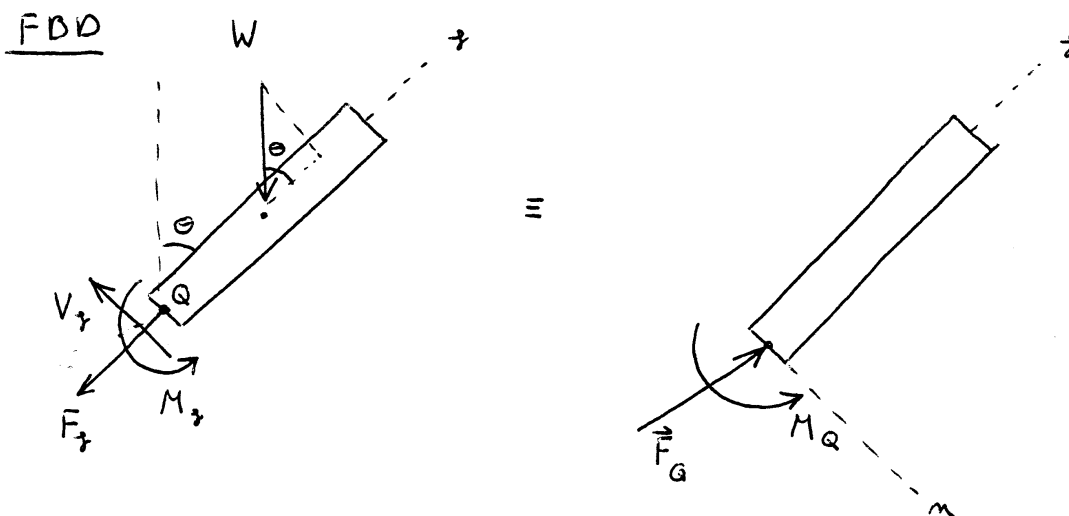

$$W = \frac{M}{l} g (l-z)$$

- 3 -

$$\therefore M_z - \frac{M}{l} g (l-z) \frac{(l-z)}{2} \sin \theta = M_Q$$

$$\Rightarrow M_z = b_1 \left[ \frac{1}{3} (l-z)^3 + \frac{1}{2} z (l-z)^2 \right] + \frac{Mg}{2l} \sin \theta (l-z)^2$$

$$\text{OR } M_z = b_2 (l-z)^2 + b_1 \left[ \frac{1}{3} (l-z)^3 + \frac{1}{2} z (l-z)^2 \right]$$

$$\text{WHERE: } b_2 = \frac{Mg}{2l} \sin \theta \quad b_1 = \frac{M}{l} \omega^2 \sin \theta \cos \theta$$

NOTE:  $M_z = 0$  @  $z = l$  END OF BEAM

LOOK AT OTHER PICTURE

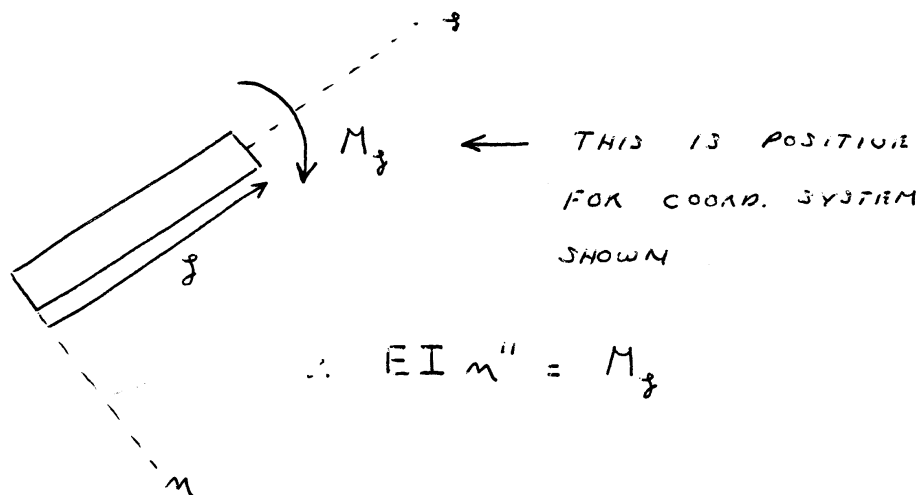

- 4 -

INTEGRATE TWICE  $\Rightarrow$  TWO CONSTANTS OF INTEGRATION  $C_1$  &  $C_2$

$$\text{IMPOSE: } \eta'(z=0) = 0 \Rightarrow C_1 = 0$$

$$\eta(z=0) = 0 \Rightarrow C_2 = 0$$

$$\Rightarrow \eta(z) = \frac{1}{EI} \left[ k_2 \left( \frac{1}{2} l^2 z^2 - \frac{1}{3} l z^3 + \frac{1}{12} z^4 \right) + k_1 \left( \frac{1}{6} l^3 z^2 - \frac{1}{12} l^2 z^3 + \frac{1}{120} z^5 \right) \right]$$

1. TIP DEFLECTION:

$$\eta_s = \frac{l^4}{EI} \left[ \frac{1}{4} k_2 + \frac{k_1 l}{120} (11) \right]$$

$$\text{OR } \eta_s = \frac{l^4}{EI} \left[ \frac{1}{4} \frac{Mg}{2l} \sin \theta + \frac{l(11)}{120} \frac{M}{l} \omega^2 \sin \theta \cos \theta \right]$$

$$\text{OR } \eta_s = \frac{Ml^3}{2EI} \sin \theta \left[ \frac{1}{4} g + \frac{11}{60} l \omega^2 \cos \theta \right]$$

## 4.10 HW 9

## 4.10.1 Problem 1

**EMA 542**  
**Home Work to be Handed In**

- 10) A thin disk of radius  $r$  and mass  $m$  is rotating about the  $z$  axis with angular velocity  $\omega$  and angular acceleration  $\alpha$ . Use angular momentum methods and direct integration to determine the bearing loads acting on the massless shaft at points A and B.

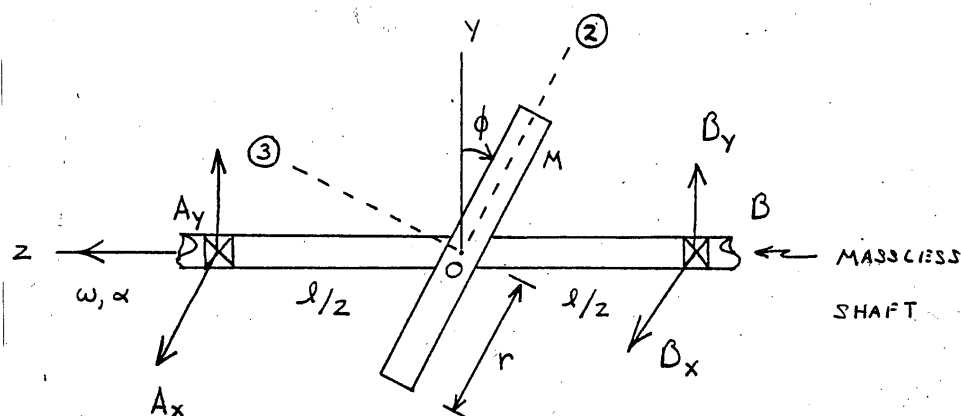

Figure 4.10: Problem description

The first step is to determine the rate of the angular momentum of the disk. This will give the torque it generates against the spinning shaft. Using free body diagram the reactions on the beam are found.

Let the body fixed coordinates C.S. have its origin at  $O$  and attached to the shaft. Hence C.S. rotates along with the shaft as in the following diagram

In the relative angular momentum method the equation of motion of  $m$  is found from

$$M_o = \dot{h}_o + m\rho \times \ddot{r}_o$$

Where  $M_o$  is torque around  $o$  and  $h_p$  is the angular momentum of the disk relative to the body fixed c.s. and  $\rho$  is the position vector from  $o$  to the center of mass of disk, and  $\ddot{r}_o$  is the absolute acceleration vector of the reference point  $o$ . But since the reference point  $o$  is fixed in space in this problem then  $\ddot{r}_o = 0$  and the above reduces to

$$M_o = \dot{h}_o$$

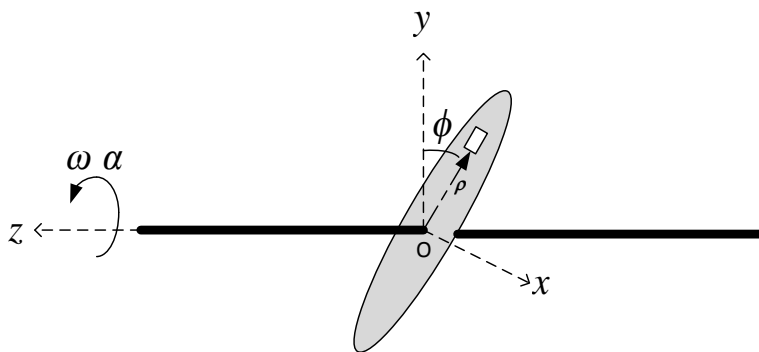

Figure 4.11: Showing body fixed coordinates

Where

$$dh_o = \rho \times \dot{\rho} dm \quad (1)$$

$dm$  is small unit mass of the disk given by

$$dm = \frac{m}{\pi r^2} dA$$

where  $dA$  is the small area of the disk to be integrated over. Let  $s = |\rho|$  be the length of the position vector from  $O$ , hence

$$\rho = -s \sin \phi \mathbf{k} + s \cos \phi \mathbf{j}$$

$$\dot{\rho} = \dot{\rho}_r + \omega_{cs} \times \rho$$

Since the angle  $\phi$  is fixed in time, hence

$$\dot{\rho}_r = 0$$

In this problem

$$\omega_{cs} = \omega \mathbf{k}$$

Therefore

$$\begin{aligned} \dot{\rho} &= \omega_{cs} \times \rho \\ &= \omega \mathbf{k} \times (-s \sin \phi \mathbf{k} + s \cos \phi \mathbf{j}) \\ &= \mathbf{i} (-\omega s \cos \phi) \end{aligned}$$

Therefore Eq. (1) becomes

$$\begin{aligned} dh_o &= (-s \sin \phi \mathbf{k} + s \cos \phi \mathbf{j}) \times \mathbf{i} (-\omega s \cos \phi) \frac{m}{\pi r^2} dA \\ dh_o &= (\mathbf{j} (\omega s^2 \sin \phi \cos \phi) + \mathbf{k} (\omega s^2 \cos \phi \cos \phi)) \frac{m}{\pi r^2} dA \end{aligned}$$

Hence

$$h_o = \int_A (\mathbf{j} (\omega s^2 \sin \phi \cos \phi) + \mathbf{k} (\omega s^2 \cos \phi \cos \phi)) \frac{m}{\pi r^2} dA$$

Polar coordinates is used to integrate this. In polar coordinates,  $dA = s ds d\theta$  where  $s$  is the current distance from the center of the disk to the unit area, hence it goes from 0 to  $r$ , and

$\theta$  goes from 0 to  $2\pi$ , therefore the above becomes

$$\begin{aligned}
 \mathbf{h}_o &= \frac{m}{\pi r^2} \int_{\theta=0}^{\theta=2\pi} \left( \int_{s=0}^{s=r} \left( \mathbf{j} \left( \omega s^2 \sin \phi \cos \phi \right) + \mathbf{k} \left( \omega s^2 \cos \phi \cos \phi \right) \right) s ds \right) d\theta \\
 &= \frac{m}{\pi r^2} \int_{\theta=0}^{\theta=2\pi} \left[ \mathbf{j} \left( \omega \frac{s^4}{4} \sin \phi \cos \phi \right) + \mathbf{k} \left( \omega \frac{s^4}{4} \cos \phi \cos \phi \right) \right]_{s=0}^{s=r} d\theta \\
 &= \frac{m}{\pi r^2} \int_{\theta=0}^{\theta=2\pi} \left( \mathbf{j} \left( \omega \frac{r^4}{4} \sin \phi \cos \phi \right) + \mathbf{k} \left( \omega \frac{r^4}{4} \cos \phi \cos \phi \right) \right) d\theta \\
 &= \frac{2\pi m}{r^2} \left( \mathbf{j} \left( \omega \frac{r^4}{4} \sin \phi \cos \phi \right) + \mathbf{k} \left( \omega \frac{r^4}{4} \cos \phi \cos \phi \right) \right) \\
 &= \frac{\omega}{2} \pi m r^2 \left( \mathbf{j} \sin \phi \cos \phi + \mathbf{k} \cos \phi \cos \phi \right)
 \end{aligned}$$

Therefore

$$\dot{\mathbf{h}}_o = \dot{\mathbf{h}}_{o,r} + \omega_{cs} \times \mathbf{h}_o$$

Where

$$\dot{\mathbf{h}}_{o,r} = \frac{\alpha}{2} \pi m r^2 \left( \mathbf{j} \sin \phi \cos \phi + \mathbf{k} \cos \phi \cos \phi \right)$$

Hence

$$\begin{aligned}
 \dot{\mathbf{h}}_o &= \frac{\alpha}{2} \pi m r^2 \left( \mathbf{j} \sin \phi \cos \phi + \mathbf{k} \cos \phi \cos \phi \right) + \omega \mathbf{k} \times \frac{\omega}{2} \pi m r^2 \left( \mathbf{j} \sin \phi \cos \phi + \mathbf{k} \cos \phi \cos \phi \right) \\
 &= \frac{\alpha}{2} \pi m r^2 \left( \mathbf{j} \sin \phi \cos \phi + \mathbf{k} \cos \phi \cos \phi \right) - \mathbf{i} \frac{\omega^2}{2} \pi m r^2 \sin \phi \cos \phi \\
 &= \mathbf{i} \frac{\omega^2}{2} \pi m r^2 \sin \phi \cos \phi + \mathbf{j} \frac{\alpha}{2} \pi m r^2 \sin \phi \cos \phi + \mathbf{k} \frac{\alpha}{2} \pi m r^2 \cos \phi \cos \phi \\
 &= \frac{\pi m r^2}{2} \left( \mathbf{i} \omega^2 \sin \phi \cos \phi + \mathbf{j} \alpha \sin \phi \cos \phi + \mathbf{k} \alpha \cos \phi \cos \phi \right)
 \end{aligned}$$

Therefore the torque generated by the rotating disk is

$$\begin{aligned}
 \mathbf{M}_o &= \dot{\mathbf{h}}_o \\
 &= \frac{\pi m r^2}{2} \left( \mathbf{i} \omega^2 \sin \phi \cos \phi + \mathbf{j} \alpha \sin \phi \cos \phi + \mathbf{k} \alpha \cos \phi \cos \phi \right)
 \end{aligned}$$

A free body diagram is now made with all the reactions on the shaft and the above found torque in order to solve for the reactions

Moment  $M_z$  is a torsion torque (twisting moment) and will not be considered since it does not affect shown reactions to be found. Only the moment in the  $xz$  plane (the  $M_x$  component) will be used to find  $A_y, B_y$  and the moment in the  $yz$  plane (the  $M_y$  component) will be used to find  $A_x, B_x$ .

Taking moments at left end of the shaft, in the  $xz$  plane, gives

$$\begin{aligned}
 M_x + B_y L &= 0 \\
 B_y &= -\frac{M_x}{L} = \frac{-\pi m r^2}{2L} \omega^2 \sin \phi \cos \phi
 \end{aligned}$$

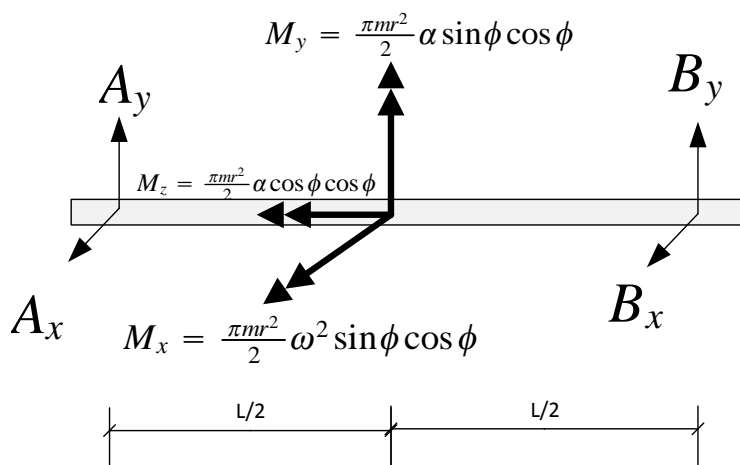

Figure 4.12: Moments and reactions on the shaft as result of disk rotation

Taking moments at right end of the shaft, in the  $xz$  plane, gives

$$M_x - A_y L = 0$$

$$A_y = \frac{\pi m r^2}{2L} \omega^2 \sin \phi \cos \phi$$

Taking moments at left end of the shaft, in the  $yz$  plane, gives

$$M_y - B_x L = 0$$

$$B_x = \frac{M_y}{L} = \frac{\pi m r^2}{2L} \alpha \sin \phi \cos \phi$$

Taking moments at right end of the shaft, in the  $yz$  plane, gives

$$M_y + A_x L = 0$$

$$A_x = \frac{-M_y}{L} = \frac{-\pi m r^2}{2L} \alpha \sin \phi \cos \phi$$



## 4.10.2 Problem 2

EMA 542

## Home Work to be Handed In

- 9) The circular platform of radius  $a$  rotates about a vertical axis at a constant angular velocity  $\omega$ . The axes  $x, y, z$  are body axes attached to the platform. A simple pendulum of mass  $m$  and length  $l$  is supported at A by a bearing which allows rotation about an axis at A parallel to the  $z$  body axis. The pendulum is constrained by a torsional spring at A with spring constant  $K_T$  which provides a torsional moment proportional to the angular displacement. The torsional spring is designed such that when  $\dot{\theta} = \ddot{\theta} = 0$ , the pendulum remains vertical for  $\omega = \text{constant}$ . At position  $\theta = -\theta_0$  as shown in the figure, the spring is undeformed. Consider that the pendulum is disturbed so that it vibrates about the vertical position  $\theta = 0$ .
- a) Determine  $\theta_0$  and the nonlinear equation for rotational motion of the pendulum about the bearing A using the relative angular momentum method.
- b) For small angles, what is the natural frequency of oscillation?

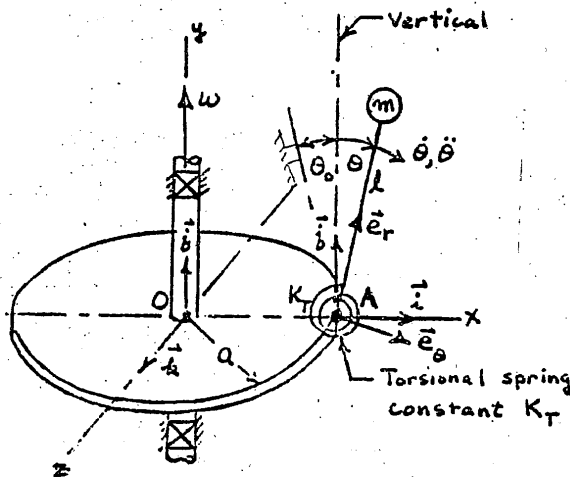

Figure 4.13: Problem description

Let the body fixed coordinate system has its origin at point A and attached to the spinning disk. The following diagram shows the general configuration used to derive the equation of motion of mass  $m$  using the relative angular momentum method.

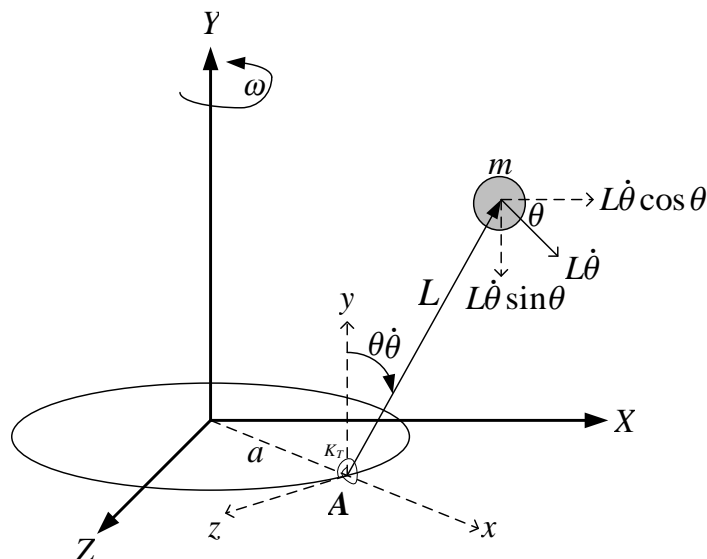

Figure 4.14: Showing body fixed C.S. used in the solution

In the relative angular momentum method, the equation of motion of  $m$  is found from

$$M_A = \dot{h}_p + m\rho \times \ddot{r}_A$$

Where  $M_A$  is summation of all moments around the reference point  $A$  and  $h_p$  is the angular momentum of  $m$  relative to the body fixed c.s. and  $\rho$  is the position vector from  $A$  to the mass  $m$ , and  $\ddot{r}_A$  is the absolute acceleration vector of the reference point  $A$ .

Now all the terms needed in the above equation are found.

$$\rho = L \sin \theta \mathbf{i} + L \cos \theta \mathbf{j} \quad (1)$$

The relative angular momentum is

$$\mathbf{h}_p = \rho \times m\dot{\rho} \quad (2)$$

The absolute angular acceleration of the body fixed coordinates system is

$$\omega_{cs} = \omega \mathbf{j}$$

We need to take the time derivative of  $\rho$ . Since this vector is rotating relative to the reference frame we use the standard method of adding the correction term

$$\dot{\rho} = \dot{\rho}_r + (\omega \mathbf{j} \times L \sin \theta \mathbf{i})$$

In the above, only the component  $L \sin \theta \mathbf{i}$  is corrected for since the body fixed axis  $i$  does rotate as seen from the inertial frame of reference. The  $L \cos \theta \mathbf{j}$  does not need to be corrected for since the body fixed axis  $j$  is aligned to the inertial axis  $J$  all the time. Evaluating the above gives

$$\begin{aligned} \dot{\rho} &= (L\dot{\theta} \cos \theta \mathbf{i} - L\dot{\theta} \sin \theta \mathbf{j}) + (\omega \mathbf{j} \times L \sin \theta \mathbf{i}) \\ &= L\dot{\theta} \cos \theta \mathbf{i} - L\dot{\theta} \sin \theta \mathbf{j} - L\omega \sin \theta \mathbf{k} \end{aligned}$$

Hence  $\mathbf{h}_p$  from Eq. (2) becomes

$$\begin{aligned}\mathbf{h}_p &= \boldsymbol{\rho} \times m\dot{\boldsymbol{\rho}} \\ &= (L \sin \theta \mathbf{i} + L \cos \theta \mathbf{j}) \times m (L\dot{\theta} \cos \theta \mathbf{i} - L\dot{\theta} \sin \theta \mathbf{j} - L\omega \sin \theta \mathbf{k}) \\ &= -L^2\dot{\theta} \sin^2 \theta \mathbf{k} + jL^2\omega \sin^2 \theta - kL^2\dot{\theta} \cos^2 \theta - \mathbf{i} (L^2\omega \cos \theta \sin \theta) \\ &= -\mathbf{i} (mL^2\omega \cos \theta \sin \theta) + mL^2\omega \sin^2 \theta \mathbf{j} - mL^2\dot{\theta} \mathbf{k}\end{aligned}$$

To make it easier to differentiate, from trig tables, let  $\cos \theta \sin \theta = \frac{1}{2} \sin(2\theta)$  so that the product rule is reduced. The above becomes

$$\mathbf{h}_p = -\mathbf{i} \left( \frac{1}{2} mL^2\omega \sin 2\theta \right) + mL^2\omega \sin^2 \theta \mathbf{j} - mL^2\dot{\theta} \mathbf{k}$$

The rate of change of relative angular momentum is

$$\begin{aligned}\dot{\mathbf{h}}_p &= \frac{d}{dt} \mathbf{h}_p + \left( \boldsymbol{\omega} \mathbf{j} \times \left( -\mathbf{i} \frac{1}{2} mL^2\omega \sin 2\theta - mL^2\dot{\theta} \mathbf{k} \right) \right) \\ &= -\mathbf{i} \left( \frac{1}{2} mL^2\omega (2\dot{\theta}) \cos 2\theta \right) + mL^2\omega (2 \sin \theta \dot{\theta} \cos \theta) \mathbf{j} - mL^2\ddot{\theta} \mathbf{k} \\ &\quad + \mathbf{k} \left( \frac{1}{2} mL^2\omega^2 \sin 2\theta \right) - (\omega mL^2\dot{\theta}) \mathbf{i}\end{aligned}$$

Hence

$$\begin{aligned}\dot{\mathbf{h}}_p &= \mathbf{i} (-mL^2\omega\dot{\theta} \cos 2\theta - \omega mL^2\dot{\theta}) + (2mL^2\dot{\theta}\omega \sin \theta \cos \theta) \mathbf{j} + \left( \frac{1}{2} mL^2\omega^2 \sin 2\theta - mL^2\ddot{\theta} \right) \mathbf{k} \\ &= \mathbf{i} (-mL^2\omega\dot{\theta} \cos 2\theta - \omega mL^2\dot{\theta}) + (mL^2\dot{\theta}\omega \sin(2\theta)) \mathbf{j} + \left( \frac{1}{2} mL^2\omega^2 \sin 2\theta - mL^2\ddot{\theta} \right) \mathbf{k}\end{aligned}$$

Applying  $\mathbf{M}_A = \dot{\mathbf{h}}_p + m\boldsymbol{\rho} \times \ddot{\mathbf{r}}_A$  and since  $\mathbf{M}_A$  is all the applied moments around  $A$ , these come from the moment applied by the torsional spring, which adds  $k_T(\theta + \theta_0)$  magnitude. The angle  $\theta_0$  is added to  $\theta$  since we are told the spring is relaxed at  $-\theta_0$ , therefore, the total angle from the relaxed position is the absolute sum of  $\theta_0$  and any additional angle.

This torsional spring moment acts counter clock wise when the pendulum swings to the right as shown. Now the weight of the mass  $m$  adds an  $mgL \sin \theta$  moment, which acts clockwise. Therefore  $\mathbf{M}_A = \dot{\mathbf{h}}_p + m\boldsymbol{\rho} \times \ddot{\mathbf{r}}_A$  becomes

$$\begin{aligned}(k_T(\theta + \theta_0) - mgL \sin \theta) \mathbf{k} &= \mathbf{i} (-mL^2\omega\dot{\theta} \cos 2\theta - \omega mL^2\dot{\theta}) + (mL^2\dot{\theta}\omega \sin(2\theta)) \mathbf{j} \\ &\quad + \left( \frac{1}{2} mL^2\omega^2 \sin 2\theta - mL^2\ddot{\theta} \right) \mathbf{k} + m\boldsymbol{\rho} \times \ddot{\mathbf{r}}_A\end{aligned}$$

$\ddot{\mathbf{r}}_A$  is the absolute acceleration of  $A$  and since  $\omega$  is constant, then only normal acceleration towards the center of disk will exist and no tangential acceleration. The normal acceleration

is  $a\omega^2\mathbf{i}$  in the negative  $i$  direction. The above becomes

$$\begin{aligned} (k_T(\theta + \theta_0) - mgL \sin \theta) \mathbf{k} &= \mathbf{i}(-mL^2\omega\dot{\theta} \cos 2\theta - \omega mL^2\dot{\theta}) + (mL^2\dot{\theta}\omega \sin(2\theta)) \mathbf{j} \\ &\quad + \left(\frac{1}{2}mL^2\omega^2 \sin 2\theta - mL^2\ddot{\theta}\right) \mathbf{k} + m(L \sin \theta \mathbf{i} + L \cos \theta \mathbf{j}) \times (-a\omega^2\mathbf{i}) \\ &= \mathbf{i}(-mL^2\omega\dot{\theta} \cos 2\theta - \omega mL^2\dot{\theta}) + (mL^2\dot{\theta}\omega \sin(2\theta)) \mathbf{j} \\ &\quad + \left(\frac{1}{2}mL^2\omega^2 \sin 2\theta - mL^2\ddot{\theta}\right) \mathbf{k} + mL a \omega^2 \cos \theta \mathbf{k} \end{aligned}$$

Considering each component at a time, 3 scalar equations are generated one for  $i$  and one for  $j$  and one for  $k$

$$0 = -mL^2\omega\dot{\theta} \cos 2\theta - \omega mL^2\dot{\theta}$$

$$0 = mL^2\dot{\theta}\omega \sin(2\theta)$$

$$k_T(\theta + \theta_0) - mgL \sin \theta = \frac{1}{2}mL^2\omega^2 \sin 2\theta - mL^2\ddot{\theta} + mL a \omega^2 \cos \theta$$

The third equation (for  $k$ ) is the only one that contains the angular acceleration of the mass  $m$  around  $A$ , hence that is the one used. Therefore the equation of motion is

$$\begin{aligned} mL^2\ddot{\theta} - mL a \omega^2 \cos \theta - mgL \sin \theta - \frac{1}{2}mL^2\omega^2 \sin 2\theta &= -k_T(\theta + \theta_0) \\ \ddot{\theta} - \frac{a\omega^2}{L} \cos \theta - \frac{g}{L} \sin \theta - \frac{1}{2}\omega^2 \sin 2\theta &= -\frac{k_T(\theta + \theta_0)}{mL^2} \end{aligned}$$

#### 4.10.2.1 Part a

To determine  $\theta_0$ , we are told that the spring is vertical when  $\dot{\theta} = \ddot{\theta} = 0$  for constant  $\omega$ . Hence from the equation of motion, letting  $\theta = 0$  (since vertical position), results in

$$\begin{aligned} -\frac{a\omega^2}{L} &= -\frac{k_T(\theta_0)}{mL^2} \\ \theta_0 &= \frac{amL\omega^2}{k_T} \quad \text{radian} \end{aligned}$$

Checking units to see the RHS has no units, since the LHS is radian (no units). Units of  $k_T$  is newton-meters per radian. Therefore

$$\frac{amL\omega^2}{k_T} = \frac{LML \frac{1}{T^2}}{\frac{ML}{T^2}L} = 1$$

Hence units are verified. The equation of motion is

$$\ddot{\theta} - \frac{a\omega^2}{L} \cos \theta - \frac{g}{L} \sin \theta - \frac{1}{2}\omega^2 \sin 2\theta = -\frac{k_T(\theta + \theta_0)}{mL^2}$$

**4.10.2.2 Part b**

For small angle,  $\cos \theta = 1$  and  $\sin 2\theta = 2\theta$ , therefore, the equation of motion becomes

$$\begin{aligned}\ddot{\theta} - \frac{a\omega^2}{L} - \frac{g}{L}2\theta - \frac{1}{2}\omega^2(2\theta) &= -\frac{k_T\theta}{mL^2} - \frac{k_T\theta_0}{mL^2} \\ \ddot{\theta} - \frac{a\omega^2}{L} - \frac{g}{L}2\theta - \theta\omega^2 + \frac{k_T\theta}{mL^2} &= -\frac{k_T\theta_0}{mL^2} \\ \ddot{\theta} - \frac{a\omega^2}{L} + \theta\left(\frac{k_T}{mL^2} - \omega^2 - \frac{2g}{L}\right) &= -\frac{k_T(\theta + \theta_0)}{mL^2}\end{aligned}$$

Therefore, the natural frequency is

$$\omega_n = \sqrt{\frac{k_T}{mL^2} - \omega^2 - \frac{2g}{L}} \quad \text{rad/sec}$$

Checking units:

$$\begin{aligned}\frac{k_T}{mL^2} - \omega^2 - \frac{2g}{L} &= \frac{\frac{ML}{T^2}L}{ML^2} - \frac{1}{T^2} - \frac{L}{T^2L} \\ &= \frac{1}{T^2} - \frac{1}{T^2} - \frac{1}{T^2} \\ &= \frac{1}{T^2}\end{aligned}$$

Hence  $\sqrt{\frac{1}{T^2}} = \frac{1}{T}$ , or per second. Hence the units match to radians per second, which is the units of the natural frequency.

## 4.10.3 key solution

## EMA 542

## Home Work to be Handed In

- 10) A thin disk of radius  $r$  and mass  $m$  is rotating about the  $z$  axis with angular velocity  $\omega$  and angular acceleration  $\alpha$ . Use angular momentum methods and direct integration to determine the bearing loads acting on the massless shaft at points A and B.

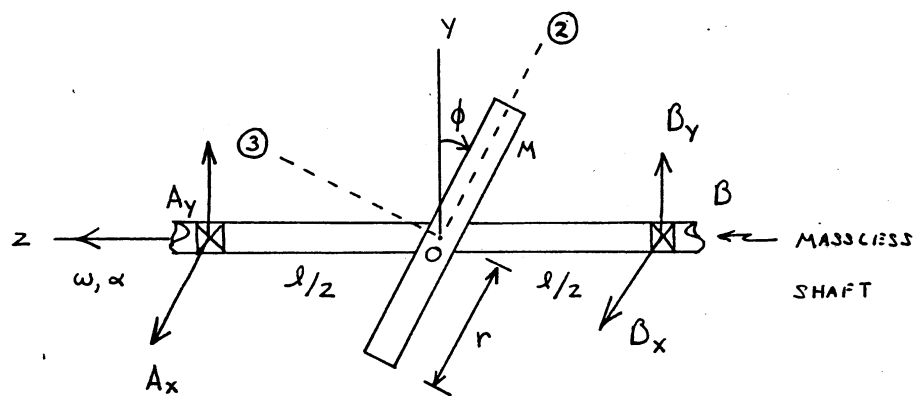

SOLUTION TO 542 HWK ⑩

$$\vec{H}_p = \dot{\vec{h}}_p + \vec{p}_c \times M \ddot{\vec{r}}_p$$

PICK PT O AS REFERENCE PT  $\Rightarrow \ddot{\vec{r}}_o = 0$

$$\therefore \vec{H}_p = \dot{\vec{h}}_p = \dot{\vec{H}}_p = \dot{\vec{H}}_o$$

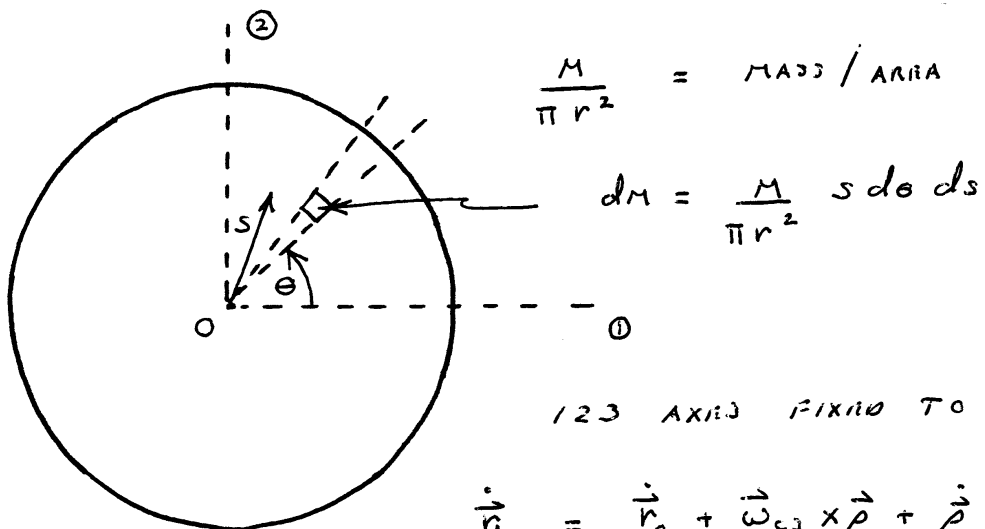

123 AXIS FIXED TO DISK

$$\dot{\vec{r}}_{dm} = \dot{\vec{r}}_o + \vec{\omega}_{c3} \times \vec{p} + \dot{\vec{p}}_r$$

$$\dot{\vec{r}}_o = 0 \quad \dot{\vec{p}}_r = 0$$

$$\vec{p} = s \cos \theta \vec{e}_1 + s \sin \theta \vec{e}_2$$

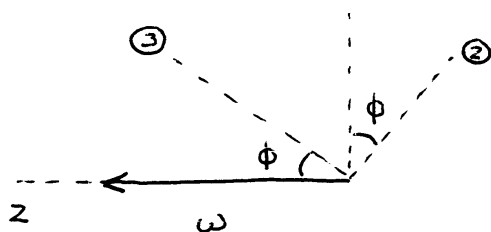

$$\vec{\omega}_{c3} = -\omega \sin \phi \vec{e}_2 + \omega \cos \phi \vec{e}_3$$

- 2 -

$$\begin{aligned}
 \dot{\vec{r}}_{dm} &= \vec{\omega}_0 \times \vec{\rho} = [-\omega \sin \phi \vec{e}_2 + \omega \cos \phi \vec{e}_3] \\
 &\quad \times [s \cos \theta \vec{e}_1 + s \sin \theta \vec{e}_2] \\
 \dot{\vec{r}}_{dm} &= \omega s \sin \phi \cos \theta \vec{e}_3 + s \omega \cos \phi \cos \theta \vec{e}_2 \\
 &\quad - \omega s \cos \phi \sin \theta \vec{e}_1
 \end{aligned}$$

ANGULAR MOMENTUM:

$$\begin{aligned}
 d\vec{H}_0 &= \vec{\rho} \times \dot{\vec{r}}_{dm} dm \\
 &= [s \cos \theta \vec{e}_1 + s \sin \theta \vec{e}_2] \\
 &\quad \times [s \sin \phi \cos \theta \vec{e}_3 + \cos \phi \cos \theta \vec{e}_2 \\
 &\quad - \cos \phi \sin \theta \vec{e}_1] \omega s^2 \frac{M}{\pi r^2} d\theta ds \\
 \Rightarrow d\vec{H}_0 &= \frac{M}{\pi r^2} \omega s^2 [-s \sin \phi \cos^2 \theta \vec{e}_2 + s \cos \phi \cos^2 \theta \vec{e}_3 \\
 &\quad + s \sin \phi \sin \theta \cos \theta \vec{e}_1 + s \cos \phi \sin^2 \theta \vec{e}_3] d\theta ds
 \end{aligned}$$



- 3 -

or

$$d\vec{H}_0 = \frac{M}{\pi r^2} \omega s^3 \left[ -\sin\phi \cos^2\theta \vec{e}_2 + \sin\phi \sin\theta \cos\theta \vec{e}_1 + \cos\phi \vec{e}_3 \right] d\theta ds$$

$$\vec{H}_0 = \int_0^r \int_0^{2\pi} \frac{M}{\pi r^2} \omega s^3 \left[ -\sin\phi \cos^2\theta \vec{e}_2 + \sin\phi \sin\theta \cos\theta \vec{e}_1 + \cos\phi \vec{e}_3 \right] d\theta ds$$

INTEGRATE FIRST IN  $\theta$ ;

$$\int_0^{2\pi} \cos^2\theta d\theta = \left[ \frac{\theta}{2} + \frac{1}{4} \sin 2\theta \right]_0^{2\pi} = \pi$$

$$\int_0^{2\pi} \sin\theta \cos\theta d\theta = \frac{\sin^2\theta}{2} \Big|_0^{2\pi} = 0$$

$$\therefore \vec{H}_0 = \frac{M}{\pi r^2} \omega \int_0^r s^3 \left[ -\pi \sin\phi \vec{e}_2 + \overset{2\pi}{\cos\phi} \vec{e}_3 \right] ds$$

$$\vec{H}_0 = \frac{M}{\pi r^2} \omega \pi \frac{1}{4} r^4 \left[ -\sin\phi \vec{e}_2 + 2 \cos\phi \vec{e}_3 \right]$$

- 4 -

$$\Rightarrow \vec{H}_0 = -\frac{1}{4} M r^2 \omega \sin \phi \vec{e}_2 + \frac{1}{2} M r^2 \omega \cos \phi \vec{e}_3$$

Now TAKE TIME DERIVATIVE!

$$\dot{\vec{H}}_0 = \dot{\vec{H}}_{0R} = \dot{\vec{H}}_{0rn} + \vec{\omega}_{cs} \times \vec{H}_0$$

$$\dot{\vec{H}}_{0rn} = -\frac{1}{4} M r^2 \alpha \sin \phi \vec{e}_2 + \frac{1}{2} M r^2 \alpha \cos \phi \vec{e}_3$$

↑ TIME DERIVATIVE IN  $\vec{e}_1, \vec{e}_2, \vec{e}_3$

$$\begin{aligned} \vec{\omega}_{cs} \times \vec{H}_0 &= \left[ -\omega \sin \phi \vec{e}_2 + \omega \cos \phi \vec{e}_3 \right] \\ &\quad \times \left[ -\frac{1}{4} M r^2 \omega \sin \phi \vec{e}_2 + \frac{1}{2} M r^2 \omega \cos \phi \vec{e}_3 \right] \\ &= -\frac{1}{2} M r^2 \omega^2 \sin \phi \cos \phi \vec{e}_1 \\ &\quad + \frac{1}{4} M r^2 \omega^2 \sin \phi \cos \phi \vec{e}_1 \\ &= -\frac{1}{4} M r^2 \omega^2 \sin \phi \cos \phi \vec{e}_1 \end{aligned}$$

$$\Rightarrow \vec{M}_0 = -\frac{1}{4} M r^2 \omega^2 \sin \phi \cos \phi \vec{e}_1 - \frac{1}{4} M r^2 \alpha \sin \phi \vec{e}_2 + \frac{1}{2} M r^2 \alpha \cos \phi \vec{e}_3$$

- 5 -

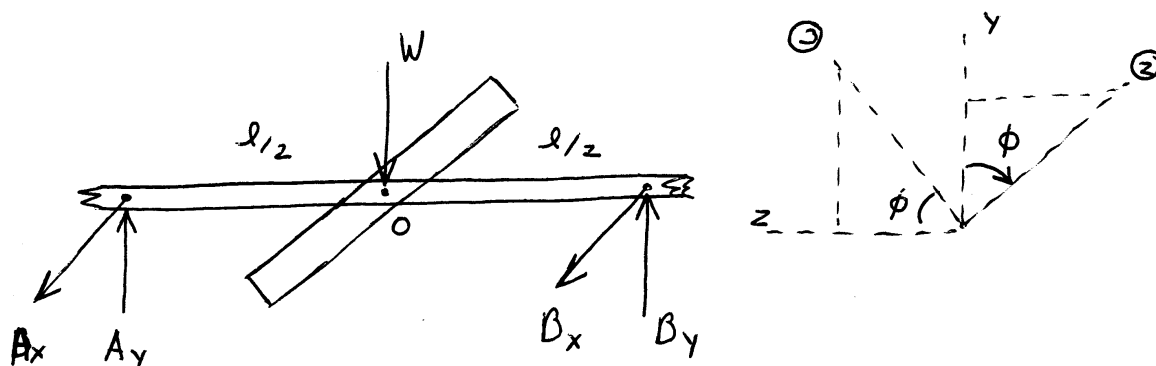

$$\vec{e}_1 = \bar{x} \quad \vec{e}_2 = \cos\phi \bar{y} - \sin\phi \bar{z}$$

$$\vec{e}_3 = \sin\phi \bar{y} + \cos\phi \bar{z}$$

$$\begin{aligned} \Rightarrow \vec{M}_O &= -\frac{1}{4} M r^2 \omega^2 \sin\phi \cos\phi \bar{x} - \frac{1}{4} M r^2 \alpha \sin\phi \cos\phi \bar{y} \\ &\quad + \frac{1}{4} M r^2 \alpha \sin^2\phi \bar{z} + \frac{1}{2} M r^2 \alpha \sin\phi \cos\phi \bar{y} \\ &\quad + \frac{1}{2} M r^2 \alpha \cos^2\phi \bar{z} \end{aligned}$$

$$\begin{aligned} \Rightarrow \vec{M}_O &= -\frac{1}{4} M r^2 \omega^2 \sin\phi \cos\phi \bar{x} + \frac{1}{4} M r^2 \alpha \sin\phi \cos\phi \bar{y} \\ &\quad + M r^2 \alpha \left[ \frac{1}{4} \sin^2\phi + \frac{1}{2} \cos^2\phi \right] \bar{z} \end{aligned}$$

Sum Forces:

$$A_y + B_y - Mg = 0 \quad (1)$$

$$A_x + B_x = 0 \quad (2)$$

- 6 -

SUM MOMENTS ABOUT O:

$$\Sigma M_x \Rightarrow -A_y \frac{l}{2} + B_y \frac{l}{2} = -\frac{1}{4} M r^2 \omega^2 \sin \phi \cos \phi \quad (3)$$

$$(1) \Rightarrow A_y = Mg - B_y$$

$$(3) \Rightarrow -Mg \frac{l}{2} + B_y \frac{l}{2} + B_y \frac{l}{2} = -\frac{1}{4} M r^2 \omega^2 \sin \phi \cos \phi$$

$$\Rightarrow B_y = -\frac{1}{4} \frac{M}{l} r^2 \omega^2 \sin \phi \cos \phi + \frac{1}{2} Mg$$

$$\Rightarrow A_y = \frac{1}{4} \frac{M}{l} r^2 \omega^2 \sin \phi \cos \phi + \frac{1}{2} Mg$$

$$\Sigma M_y \Rightarrow A_x \frac{l}{2} - B_x \frac{l}{2} = \frac{1}{4} M r^2 \alpha \sin \phi \cos \phi \quad (4)$$

$$(2) \Rightarrow A_x = -B_x$$

$$(4) \Rightarrow A_x = \frac{1}{4} \frac{M}{l} r^2 \alpha \sin \phi \cos \phi$$

$$B_x = -\frac{1}{4} \frac{M}{l} r^2 \alpha \sin \phi \cos \phi$$

EMA 542  
Home Work to be Handed In

- 9) The circular platform of radius  $a$  rotates about a vertical axis at a constant angular velocity  $\omega$ . The axes  $x, y, z$  are body axes attached to the platform. A simple pendulum of mass  $m$  and length  $l$  is supported at A by a bearing which allows rotation about an axis at A parallel to the  $z$  body axis. The pendulum is constrained by a torsional spring at A with spring constant  $K_T$  which provides a torsional moment proportional to the angular displacement. The torsional spring is designed such that when  $\dot{\theta} = \ddot{\theta} = 0$ , the pendulum remains vertical for  $\omega = \text{constant}$ . At position  $\theta = -\theta_0$  as shown in the figure, the spring is undeformed. Consider that the pendulum is disturbed so that it vibrates about the vertical position  $\theta = 0$ .
- a) Determine  $\theta_0$  and the nonlinear equation for rotational motion of the pendulum about the bearing A using the **relative angular momentum method**.
- b) For small angles, what is the natural frequency of oscillation?

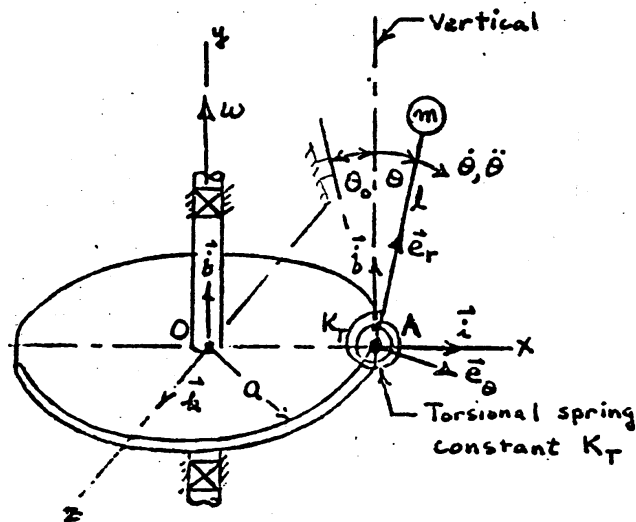

## SOLUTION TO 542 HWK 9

$\omega = \text{CONSTANT}$        $\text{MASS} = M$        $\text{SPRING} = K_T$

$\omega = \omega \Rightarrow \theta = 0 = \dot{\theta} = \ddot{\theta}$        $\text{STEADY STATE}$

USING RELATIVE ANGULAR MOMENTUM:

$$\vec{M}_P = \dot{\vec{h}}_P + \vec{p} \times M \ddot{\vec{r}}_P \quad A = P$$

$$\vec{p} = l \sin \theta \vec{i} + l \cos \theta \vec{j}$$

$$\ddot{\vec{r}}_A = -a \omega^2 \vec{i} \quad \text{STEADY CIRCULAR MOTION}$$

$$\begin{aligned} \Rightarrow \underline{\vec{p} \times M \ddot{\vec{r}}_P} &= [l \sin \theta \vec{i} + l \cos \theta \vec{j}] \times (-a \omega^2 \vec{i}) M \\ &= M l a \omega^2 \cos \theta \vec{k} \end{aligned} \quad (1)$$

FORM APPARENT ANGULAR MOMENTUM:

$$\vec{h}_A = \vec{p} \times M \dot{\vec{p}}$$

$$\vec{V}_M = \vec{V}_A + \vec{\omega}_{C3} \times \vec{p} + \dot{\vec{p}} \quad (2)$$

FIX XYZ TO PLATFORM AND PLACE ORIGIN  
AT A.

- 2 -

$$\dot{\vec{p}} = \vec{V}_M - \vec{V}_A = \vec{\omega}_{cs} \times \vec{p} + \dot{\vec{p}}_r \quad \begin{array}{l} \text{RELATIVE} \\ \text{VELOCITY} \end{array}$$

$$\vec{\omega}_{cs} = \omega \bar{j}$$

$$\begin{aligned} \vec{\omega}_{cs} \times \vec{p} &= \omega \bar{j} \times [l \sin \theta \bar{i} + l \cos \theta \bar{j}] \\ &= -l \omega \sin \theta \bar{k} \end{aligned}$$

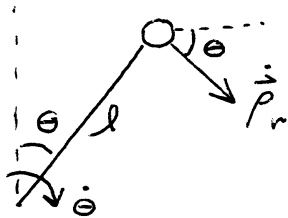

$$\dot{\vec{p}}_r = l \dot{\theta} \cos \theta \bar{i} - l \dot{\theta} \sin \theta \bar{j}$$

$$\therefore \underline{\dot{\vec{p}}} = l \dot{\theta} \cos \theta \bar{i} - l \dot{\theta} \sin \theta \bar{j} - l \omega \sin \theta \bar{k}$$

$$\begin{aligned} \therefore \vec{h}_A &= M [l \sin \theta \bar{i} + l \cos \theta \bar{j}] \times [l \dot{\theta} \cos \theta \bar{i} \\ &\quad - l \dot{\theta} \sin \theta \bar{j} - l \omega \sin \theta \bar{k}] \\ &= M [-l^2 \dot{\theta} \sin^2 \theta \bar{k} + l^2 \omega \sin^2 \theta \bar{j} \\ &\quad - l^2 \dot{\theta} \cos^2 \theta \bar{k} - l^2 \omega \cos \theta \sin \theta \bar{i}] \end{aligned}$$

- 3 -

$$\Rightarrow \underline{\vec{h}_A} = -Ml^2\omega \sin\theta \cos\theta \bar{i} + l^2 M \omega \sin^2\theta \bar{j} - Ml^2\dot{\theta} \bar{k}$$

TAKE TIME DERIVATIVE:

$$\dot{\vec{h}}_{AR} = \dot{\vec{h}}_{AV} + \vec{\omega}_{CS} \times \vec{h}_A = \dot{\vec{h}}_A \quad \text{TOTAL DERIVATIVE}$$

$$\underline{\vec{\omega}_{CS} \times \vec{h}_A} = \omega \bar{j} \times [-Ml^2\omega \sin\theta \cos\theta \bar{i} + Ml^2\omega \sin^2\theta \bar{j} - Ml^2\dot{\theta} \bar{k}]$$

$$= Ml^2\omega^2 \sin\theta \cos\theta \bar{k} - Ml^2\dot{\theta}\omega \bar{i}$$

$$\underline{\dot{\vec{h}}_{AR}} = \text{TIME DERIVATIVE WITHIN XYZ}$$

$$= [-Ml^2\omega\dot{\theta} \cos^2\theta + Ml^2\omega\dot{\theta} \sin^2\theta] \bar{i}$$

$$+ 2Ml^2\omega\dot{\theta} \sin\theta \cos\theta \bar{j} - Ml^2\ddot{\theta} \bar{k}$$

$$\therefore \dot{\vec{h}}_A = [-Ml^2\omega\dot{\theta} \cos^2\theta + Ml^2\omega\dot{\theta} \sin^2\theta - Ml^2\ddot{\theta}] \bar{i}$$

$$+ 2Ml^2\omega\dot{\theta} \sin\theta \cos\theta \bar{j} + [-Ml^2\ddot{\theta}$$

$$+ Ml^2\omega^2 \sin\theta \cos\theta] \bar{k}$$



-4-

$$\begin{aligned} \therefore \vec{M}_p &= [\sin^2 \theta - \cos^2 \theta - 1] M l^2 \dot{\omega} \vec{i} \\ &+ 2 M l^2 \dot{\omega} \sin \theta \cos \theta \vec{j} \\ &+ [-M l^2 \ddot{\theta} + M l^2 \omega^2 \sin \theta \cos \theta \\ &+ M l a \omega^2 \cos \theta] \vec{k} \end{aligned}$$

LOOK AT Z COMPONENT:

$$\Rightarrow M_z = -M g l \sin \theta + K_T (\theta_0 + \theta)$$

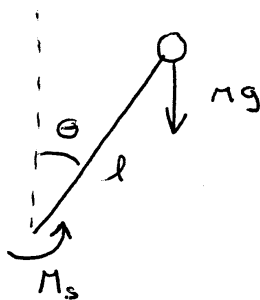

$$\therefore -M g l \sin \theta + K_T (\theta_0 + \theta)$$

$$\begin{aligned} &= -M l^2 \ddot{\theta} + M l^2 \omega^2 \sin \theta \cos \theta \\ &+ M l a \omega^2 \cos \theta \end{aligned}$$

$$\Rightarrow M l^2 \ddot{\theta} + K_T (\theta_0 + \theta) - M l^2 \omega^2 \sin \theta \cos \theta$$

$$- M l a \omega^2 \cos \theta - M g l \sin \theta = 0$$

-5-

AT STEADY STATE:  $\theta = 0$   $\ddot{\theta} = 0$

$$\Rightarrow K_T \theta_0 - M l a \omega^2 = 0$$

$$\Rightarrow \boxed{\theta_0 = \frac{M l a \omega^2}{K_T}}$$

$$\begin{aligned} \Rightarrow \ddot{\theta} + \frac{K_T}{M l^2} \theta - \omega^2 \sin \theta \cos \theta \\ + \frac{a}{l} \omega^2 (1 - \cos \theta) - \frac{g}{l} \sin \theta = 0 \end{aligned}$$

FOR SMALL ANGLES:

$$\ddot{\theta} + \left[ \frac{K_T}{M l^2} - \omega^2 - \frac{g}{l} \right] \theta = 0$$

$$\Rightarrow \boxed{\omega_N = \left[ \frac{K_T}{M l^2} - \omega^2 - \frac{g}{l} \right]^{1/2}}$$

## 4.11 HW 10

## 4.11.1 Problem 1

## EMA 542

## Home Work to be Handed In

- 11) The airplane shown in the figure below is in the process of making a steady horizontal turn at the rate  $\omega_p$ . During this motion, the airplane's propeller is spinning at the rate of  $\omega_s$ . If the propeller has two blades, determine the moments which the propeller shaft exerts on the propeller when the blades are in the vertical position. For simplicity, assume the propeller to be a uniform slender bar with total mass  $m$  AND LENGTH  $l$ .

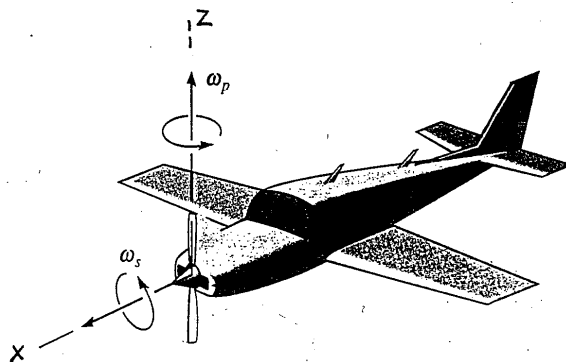

Figure 4.15: Problem description

We need to write everything in using body principal axes  $e_1, e_2, e_3$ . Here is the model to use

Let  $\omega$  be the absolute angular velocity of the body but written using its principal unit vectors. The body in this case is the propeller which is shown above as a small bar. The  $e_1, e_2, e_3$  are the body fixed principal axes of the propeller. Therefore

$$\omega = \omega_s e_1 + \omega_p \sin \theta e_2 + \omega_p \cos \theta e_3$$

But  $\dot{\theta} = \omega_s$ . This is the absolute angular velocity of the propeller itself. Hence

$$\omega = \dot{\theta} e_1 + \omega_p \sin \theta e_2 + \omega_p \cos \theta e_3$$

We want to write everything using body principal axes to avoid taking derivatives for moments of inertia. When using  $e_1, e_2, e_3$  then the moments of inertia of the propeller are constant relative to its own principal axes and also all the cross products of moments of

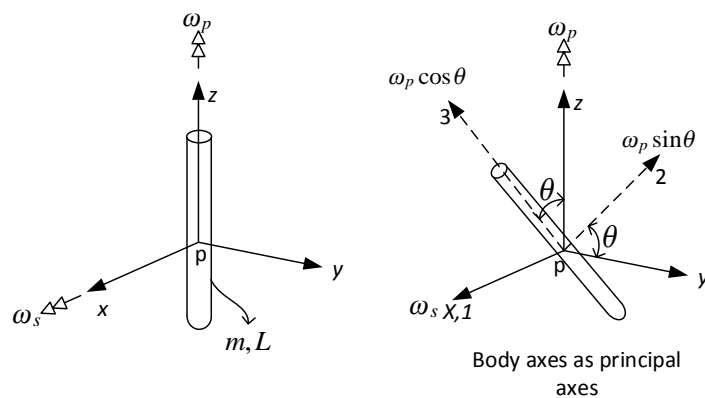

Figure 4.16: Model used

inertia are zero, and only  $I_1, I_2, I_3$  need to be used, which simplifies the equations.

$$\begin{aligned}\dot{\omega} &= \dot{\theta} \mathbf{e}_1 + \omega_p \dot{\theta} \cos \theta \mathbf{e}_2 - \dot{\theta} \omega_p \sin \theta \mathbf{e}_3 \\ &= \omega_p \dot{\theta} \cos \theta \mathbf{e}_2 - \dot{\theta} \omega_p \sin \theta \mathbf{e}_3\end{aligned}$$

Modeling propeller as uniform slender bar

$$\begin{aligned}I_1 &= \frac{mL^2}{12} \\ I_2 &= \frac{mL^2}{12} \\ I_3 &\sim 0\end{aligned}$$

The reference point used is the origin which is fixed on the body. Hence

$$M \boldsymbol{\rho}_c \times \ddot{\mathbf{r}}_p = 0$$

$$\mathbf{h}_p = \begin{pmatrix} I_1 & 0 & 0 \\ 0 & I_2 & 0 \\ 0 & 0 & I_3 \end{pmatrix} \begin{pmatrix} \omega_1 \\ \omega_2 \\ \omega_3 \end{pmatrix}$$

And

$$\begin{aligned}\dot{\mathbf{h}}_p &= \begin{pmatrix} \dot{h}_1 \\ \dot{h}_2 \\ \dot{h}_3 \end{pmatrix} = \begin{pmatrix} I_1 \dot{\omega}_1 + \omega_2 \omega_3 (I_3 - I_2) \\ I_2 \dot{\omega}_2 + \omega_1 \omega_3 (I_1 - I_3) \\ I_3 \dot{\omega}_3 + \omega_1 \omega_2 (I_2 - I_1) \end{pmatrix} \\ &= \begin{pmatrix} \omega_p^2 \sin \theta \cos \theta \left(-\frac{mL^2}{12}\right) \\ \frac{mL^2}{12} \omega_p \dot{\theta} \cos \theta + \dot{\theta} \omega_p \cos \theta \left(\frac{mL^2}{12}\right) \\ \dot{\theta} \omega_p \sin \theta \left(\frac{mL^2}{12} - \frac{mL^2}{12}\right) \end{pmatrix} \\ &= \begin{pmatrix} -\frac{mL^2}{12} \omega_p^2 \sin \theta \cos \theta \\ \frac{mL^2}{6} \omega_p \dot{\theta} \cos \theta \\ 0 \end{pmatrix}\end{aligned}$$

Hence

$$\begin{aligned}M_o &= \dot{\mathbf{h}}_p + \overbrace{m \boldsymbol{\rho}_c \times \ddot{\mathbf{r}}_o}^{0 \text{ (fixed point)}} \\ &= \dot{\mathbf{h}}_p\end{aligned}$$

When in vertical position, the angle  $\theta$  is zero, hence the dynamic moment is

$$M_o = \frac{mL^2}{6} \omega_p \dot{\theta} \mathbf{e}_2$$

Converting back to  $xyz$  coordinates

$$M_o = \frac{mL^2}{4} \omega_p \omega_s \mathbf{j}$$

Hence this is the torque value when  $\theta = 0$

$$\tau = \frac{mL^2}{6} \omega_p \omega_s \mathbf{j}$$

Check units:  $(ML^2) \frac{1}{T} \frac{1}{T} = \left(\frac{ML}{T^2}\right) L = \text{Force} \times \text{Length}$ . Units agree. (I had expected the torque to be in the  $k$  axes direction first. I went over this few times and do not see if I did something wrong).

### 4.11.2 Problem 2

Let  $\boldsymbol{\omega}$  be the absolute angular velocity of the body but written using its principal unit vectors. The body in this case is the block. The  $\mathbf{e}_1, \mathbf{e}_2, \mathbf{e}_3$  are the body fixed principal axes of block. Therefore

$$\boldsymbol{\omega} = \omega_o \cos \phi \mathbf{e}_1 - \omega_o \sin \phi \mathbf{e}_2 + \dot{\phi} \mathbf{e}_3$$

We want to write everything using body principal axes to avoid taking derivatives for moments of inertia. When using  $\mathbf{e}_1, \mathbf{e}_2, \mathbf{e}_3$  then the moments of inertia of the propeller are constant relative to its own principal axes and also all the cross products of moments of

HWIK TO HAND IN

12. As shown below, the homogeneous rectangular block of mass  $m$  is centrally mounted on the shaft  $A-A$  about which it rotates with a constant speed  $\dot{\phi} = p$ . Meanwhile the yoke is forced to rotate about the  $x$ -axis with a constant speed  $\omega_0$ . Find the magnitude of the torque  $M$  as a function of  $\phi$ . The center  $O$  of the block is the origin of the  $x-y-z$  coordinates. Principal axes 1-2-3 are attached to the block as shown, and with respect to these axes:

$$I_{11} = m(a^2 + b^2)/12$$

$$I_{22} = m(b^2 + c^2)/12$$

$$I_{33} = m(a^2 + c^2)/12$$

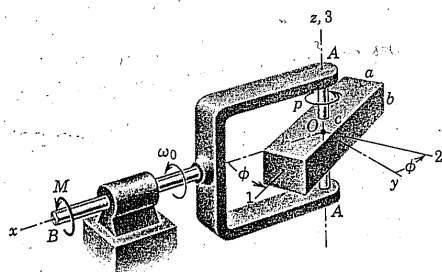

Figure 4.17: Problem description

inertia are zero, and only  $I_1, I_2, I_3$  need to be used, which simplifies the equations.

$$\dot{\omega} = -\omega_o \dot{\phi} \sin \phi \mathbf{e}_1 - \omega_o \dot{\phi} \cos \phi \mathbf{e}_2$$

Using

$$I_1 = \frac{m(a^2 + b^2)}{12}$$

$$I_2 = \frac{m(b^2 + c^2)}{12}$$

$$I_3 = \frac{m(a^2 + c^2)}{12}$$

The reference point used is the origin which is fixed on the body. Hence

$$M\rho_c \times \ddot{\mathbf{r}}_p = 0$$

$$\mathbf{h}_p = \begin{pmatrix} I_1 & 0 & 0 \\ 0 & I_2 & 0 \\ 0 & 0 & I_3 \end{pmatrix} \begin{pmatrix} \omega_1 \\ \omega_2 \\ \omega_3 \end{pmatrix}$$

And

$$\dot{\omega} = -\omega_o \dot{\phi} \sin \phi \mathbf{e}_1 - \omega_o \dot{\phi} \cos \phi \mathbf{e}_2$$

$$\omega = \omega_o \cos \phi \mathbf{e}_1 - \omega_o \sin \phi \mathbf{e}_2 + \dot{\phi} \mathbf{e}_3$$

$$\begin{aligned} \dot{\mathbf{h}}_p &= \begin{pmatrix} \dot{h}_1 \\ \dot{h}_2 \\ \dot{h}_3 \end{pmatrix} = \begin{pmatrix} I_1 \dot{\omega}_1 + \omega_2 \omega_3 (I_3 - I_2) \\ I_2 \dot{\omega}_2 + \omega_1 \omega_3 (I_1 - I_3) \\ I_3 \dot{\omega}_3 + \omega_1 \omega_2 (I_2 - I_1) \end{pmatrix} \\ &= \begin{pmatrix} -I_1 \omega_o \dot{\phi} \sin \phi - \dot{\phi} \omega_o \sin \phi (I_3 - I_2) \\ -I_2 \omega_o \dot{\phi} \cos \phi + \omega_o \dot{\phi} \cos \phi (I_1 - I_3) \\ -\omega_o^2 \cos \phi \sin \phi (I_2 - I_1) \end{pmatrix} \\ &= \begin{pmatrix} \dot{\phi} \omega_o \sin \phi (I_2 - I_3 - I_1) \\ \omega_o \dot{\phi} \cos \phi (I_1 - I_3 - I_2) \\ \omega_o^2 \cos \phi \sin \phi (I_2 - I_1) \end{pmatrix} \\ &= \begin{pmatrix} p \omega_o \sin \phi (I_3 - I_2 - I_1) \\ \omega_o p \cos \phi (I_1 - I_3 - I_2) \\ \omega_o^2 \cos \phi \sin \phi (I_2 - I_1) \end{pmatrix} \end{aligned}$$

Hence

$$\begin{aligned} \mathbf{M}_o &= \dot{\mathbf{h}}_p + \overbrace{m\rho_c \times \ddot{\mathbf{r}}_o}^{0 \text{ (fixed point)}} \\ &= \dot{\mathbf{h}}_p \end{aligned}$$

Convert back to  $xyz$  coordinates using

$$\begin{aligned} \mathbf{e}_3 &= \mathbf{k} \\ \mathbf{e}_2 &= \mathbf{j} \cos \phi - \mathbf{i} \sin \phi \\ \mathbf{e}_1 &= \mathbf{i} \cos \phi + \mathbf{j} \sin \phi \end{aligned}$$

Hence

$$\begin{aligned} \mathbf{M}_o &= [p\omega_o \sin \phi (I_2 - I_3 - I_1)](\mathbf{i} \cos \phi + \mathbf{j} \sin \phi) \\ &\quad + [\omega_o p \cos \phi (I_1 - I_3 - I_2)](\mathbf{j} \cos \phi - \mathbf{i} \sin \phi) \\ &\quad + \omega_o^2 \cos \phi \sin \phi (I_2 - I_1) \mathbf{k} \end{aligned}$$

Or

$$\begin{aligned} \mathbf{M}_o &= \mathbf{i} [p\omega_o \sin \phi \cos \phi (I_2 - I_3 - I_1) - \omega_o p \cos \phi \sin \phi (I_1 - I_3 - I_2)] \\ &\quad + \mathbf{j} [-p\omega_o \sin \phi (I_3 - I_2 - I_1) + \omega_o p \cos \phi (I_1 - I_3 - I_2)] \\ &\quad + \omega_o^2 \cos \phi \sin \phi (I_2 - I_1) \mathbf{k} \end{aligned}$$

Or

$$\begin{aligned} \mathbf{M}_o &= 2(I_2 - I_1) p\omega_o \sin \phi \cos \phi \mathbf{i} \\ &\quad + p\omega_o (-\sin \phi (I_3 - I_2 - I_1) + \cos \phi (I_1 - I_3 - I_2)) \mathbf{j} \\ &\quad + \omega_o^2 \cos \phi \sin \phi (I_2 - I_1) \mathbf{k} \end{aligned}$$

So the torque  $M_t$  is the  $\mathbf{i}$  component above, Hence

$$\begin{aligned} M_t &= 2(I_2 - I_1) p\omega_o \sin \phi \cos \phi \mathbf{i} \\ &= 2 \left( \frac{m(b^2 + c^2)}{12} - \frac{m(a^2 + b^2)}{12} \right) p\omega_o \sin \phi \cos \phi \mathbf{i} \\ &= \frac{1}{6} m (c^2 - a^2) p\omega_o \sin \phi \cos \phi \mathbf{i} \end{aligned}$$



## 4.11.3 key solution

## EMA 542

## Home Work to be Handed In

- 11) The airplane shown in the figure below is in the process of making a steady horizontal turn at the rate  $\omega_p$ . During this motion, the airplane's propeller is spinning at the rate of  $\omega_s$ . If the propeller has two blades, determine the moments which the propeller shaft exerts on the propeller when the blades are in the vertical position. For simplicity, assume the propeller to be a uniform slender bar with total mass  $m$  AND LENGTH  $l$ .

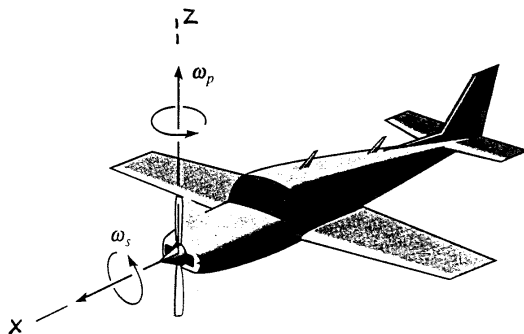

ATTACH 123 TO PROBLEM

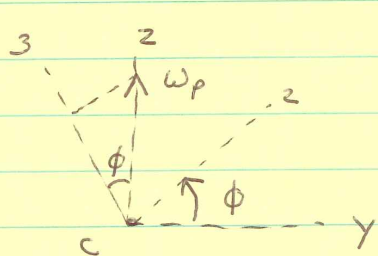

$$\vec{\omega} = \omega_3 \vec{e}_1 + \omega_p \sin\phi \vec{e}_2 + \omega_p \cos\phi \vec{e}_3$$

$$I_1 = \frac{1}{12} m l^2 = I_2$$

$$I_3 = 0$$

$$\Rightarrow \vec{M}_c = \dot{\vec{h}}_c$$

$$\vec{h}_c = \frac{1}{12} m l^2 \omega_3 \vec{e}_1 + \frac{1}{12} m l^2 \omega_p \sin\phi \vec{e}_2$$

$$\dot{\vec{h}}_c = \dot{\vec{h}}_{c0} + \vec{\omega} \times \vec{h}_c$$

$$\dot{\vec{h}}_{c0} = \frac{1}{12} m l^2 \omega_p \dot{\phi} \cos\phi \vec{e}_2 = \frac{1}{12} m l^2 \omega_p \omega_3 \vec{e}_2 \text{ @ } \phi=0$$

$$\vec{\omega} \times \vec{h}_c = (\omega_3 \vec{e}_1 + \omega_p \sin\phi \vec{e}_2 + \omega_p \cos\phi \vec{e}_3) \times (\frac{1}{12} m l^2 \omega_3 \vec{e}_1 + \frac{1}{12} m l^2 \omega_p \sin\phi \vec{e}_2)$$

$$\text{on @ } \phi=0, \vec{\omega} \times \vec{h}_c = (\omega_3 \vec{e}_1 + \omega_p \vec{e}_3) \times \frac{1}{12} m l^2 \omega_3 \vec{e}_1 = \frac{1}{12} m l^2 \omega_p \omega_3 \vec{e}_2$$

$$\Rightarrow \vec{M}_c = \dot{\vec{h}}_c = \frac{1}{6} m l^2 \omega_p \omega_3 \vec{e}_2$$

$$\text{on } M_x = 0 \quad M_y = \frac{1}{6} m l^2 \omega_p \omega_3 \quad M_z = 0$$

## Example 21-5

The airplane shown in Fig. 21-13a is in the process of making a steady *horizontal* turn at the rate of  $\omega_p$ . During this motion, the airplane's propeller is spinning at the rate of  $\omega_s$ . If the propeller has two blades, determine the moments which the propeller shaft exerts on the propeller when the blades are in the vertical position. For simplicity, assume the blades to be a uniform slender bar having a moment of inertia  $I$  about an axis perpendicular to the blades and passing through their center, and having zero moment of inertia about a longitudinal axis.

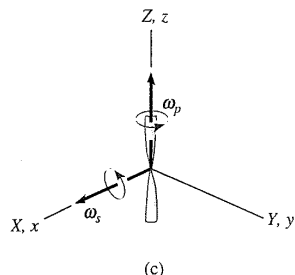
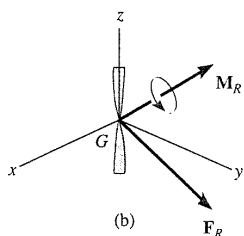
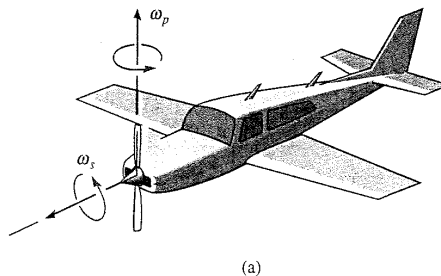

Fig. 21-13

## SOLUTION

**Free-Body Diagram.** Fig. 21-13b. The effect of the connecting shaft on the propeller is indicated by the resultants  $\mathbf{F}_R$  and  $\mathbf{M}_R$ . (The propeller's weight is assumed to be negligible.) The  $x, y, z$  axes will be taken fixed to the propeller, since these axes always represent the principal axes of inertia for the propeller. Thus,  $\boldsymbol{\Omega} = \boldsymbol{\omega}$ . The moments of inertia  $I_x$  and  $I_y$  are equal ( $I_x = I_y = I$ ) and  $I_z = 0$ .

**Kinematics.** The angular velocity of the  $x, y, z$  axes observed from the  $X, Y, Z$  axes, coincident with the  $x, y, z$  axes, Fig. 21-13c, is  $\boldsymbol{\omega} = \omega_s \mathbf{i} + \omega_p \mathbf{k}$ , so that the  $x, y, z$  components of  $\boldsymbol{\omega}$  are

$$\omega_x = \omega_s \quad \omega_y = 0 \quad \omega_z = \omega_p$$

Since  $\boldsymbol{\Omega} = \boldsymbol{\omega}$ , then  $\dot{\boldsymbol{\omega}} = (\dot{\boldsymbol{\omega}})_{xyz}$ . Hence, like Example 21-4, the time derivative of  $\boldsymbol{\omega}$  will be computed with respect to the fixed  $X, Y, Z$  axes and then  $\dot{\boldsymbol{\omega}}$  will be resolved into components along the moving  $x, y, z$  axes to obtain  $(\dot{\boldsymbol{\omega}})_{xyz}$ . To do this, Eq. 20-6 must be used since  $\boldsymbol{\omega}$  is changing direction relative to  $X, Y, Z$ . (Note that this was unnecessary for the case in Example 21-4.) Since  $\boldsymbol{\omega} = \omega_s \mathbf{i} + \omega_p \mathbf{k}$ , then  $\dot{\boldsymbol{\omega}} = \dot{\omega}_s \mathbf{i} + \dot{\omega}_p \mathbf{k}$ . Similar to Example 20-1, the time rate of change of each of these components relative to the  $X, Y, Z$  axes can be obtained by using a third coordinate system  $x', y', z'$ , which has an angular velocity  $\boldsymbol{\Omega}' = \omega_p \mathbf{k}$  and is coincident with the  $X, Y, Z$  axes at the instant shown. Thus

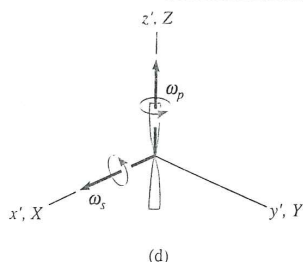

$$\begin{aligned} \dot{\omega} &= (\dot{\omega})_{x'y'z'} + \Omega' \times \omega \\ &= (\dot{\omega}_s)_{x'y'z'} + (\dot{\omega}_p)_{x'y'z'} + \omega_p \times (\omega_s + \omega_p) \\ &= 0 + 0 + \omega_p \times \omega_s + \omega_p \times \omega_p \\ &= 0 + 0 + \omega_p \mathbf{k} \times \omega_s \mathbf{i} + 0 = \omega_p \omega_s \mathbf{j} \end{aligned}$$

Since the  $X, Y, Z$  axes are also coincident with the  $x, y, z$  axes at the instant shown, Fig. 21-13d, the components of  $\dot{\omega}$  along these axes are

$$\dot{\omega}_x = 0 \quad \dot{\omega}_y = \omega_p \omega_s \quad \dot{\omega}_z = 0$$

These same results can, of course, also be determined by direct calculation of  $(\dot{\omega})_{xyz}$ . To do this, it will be necessary to view the propeller in some general position such as shown in Fig. 21-13e. Here the plane has turned through an angle  $\phi$  and the propeller has turned through an angle  $\psi$  relative to the plane. Notice that  $\omega_p$  is always directed along the fixed  $Z$  axis and  $\omega_s$  follows the  $x$  axis. Thus the components of  $\omega$  are

$$\omega_x = \omega_s \quad \omega_y = -\omega_p \sin \psi \quad \omega_z = \omega_p \cos \psi$$

Since  $\omega_s$  and  $\omega_p$  are constant, the time derivatives of these components become

$$\dot{\omega}_x = 0 \quad \dot{\omega}_y = \omega_p \cos \psi \dot{\psi} \quad \dot{\omega}_z = \omega_p \sin \psi \dot{\psi}$$

but  $\psi = 0^\circ$  and  $\dot{\psi} = \omega_s$  at the instant considered. Thus,

$$\dot{\omega}_x = 0 \quad \dot{\omega}_y = \omega_p \omega_s \quad \dot{\omega}_z = 0$$

which are the same results as those computed above.

*Equations of Motion.* Using Eqs. 21-25, we have

$$\Sigma M_x = I_x \dot{\omega}_x - (I_y - I_z) \omega_y \omega_z = I(0) - (I - 0)(0) \omega_p$$

$$M_x = 0$$

Ans.

$$\Sigma M_y = I_y \dot{\omega}_y - (I_z - I_x) \omega_z \omega_x = I(\omega_p \omega_s) - (0 - I) \omega_p \omega_s$$

$$M_y = 2I \omega_p \omega_s$$

Ans.

$$\Sigma M_z = I_z \dot{\omega}_z - (I_x - I_y) \omega_x \omega_y = 0(0) - (I - I) \omega_s(0)$$

$$M_z = 0$$

Ans.

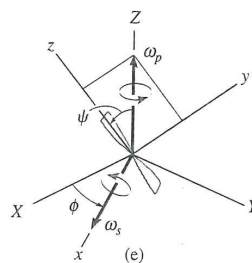

Fig. 21-13 (cont'd)

$$M_y = \frac{1}{6} M l^2 \omega_p \omega_s$$

$$I = \frac{1}{12} M l^2$$

## HWK TO HAND IN

12. As shown below, the homogeneous rectangular block of mass  $m$  is centrally mounted on the shaft  $A-A$  about which it rotates with a constant speed  $\dot{\phi} = p$ . Meanwhile the yoke is forced to rotate about the  $x$ -axis with a constant speed  $\omega_0$ . Find the magnitude of the torque  $M$  as a function of  $\phi$ . The center  $O$  of the block is the origin of the  $x-y-z$  coordinates. Principal axes 1-2-3 are attached to the block as shown, and with respect to these axes:

$$I_{11} = m(a^2 + b^2)/12$$

$$I_{22} = m(b^2 + c^2)/12$$

$$I_{33} = m(a^2 + c^2)/12$$

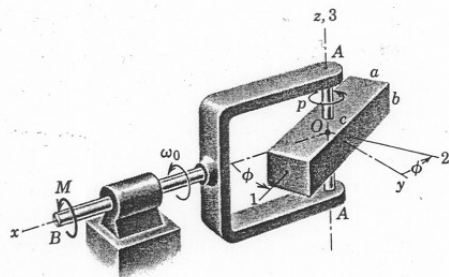

SOLUTION FOR 2

$$\dot{\phi} = \rho = \text{CONST.}$$

$$\omega_0 = \text{CONST.}$$

USE 123 BODY COORD. SYSTEM

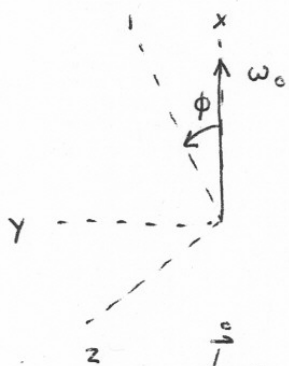

$$\vec{\omega} = \omega_0 \cos \phi \vec{e}_1 - \omega_0 \sin \phi \vec{e}_2 + \rho \vec{e}_3$$

$$\Rightarrow \vec{h} = I_{11} \omega_0 \cos \phi \vec{e}_1 - I_{22} \omega_0 \sin \phi \vec{e}_2 + I_{33} \rho \vec{e}_3$$

$$\dot{\vec{h}} = \dot{\vec{h}} + \vec{\omega} \times \vec{h}$$

$$\dot{\vec{h}} = -I_{11} \omega_0 \dot{\phi} \sin \phi \vec{e}_1 - I_{22} \omega_0 \dot{\phi} \cos \phi \vec{e}_2$$

$$\vec{\omega} \times \vec{h} = [\omega_0 \cos \phi \vec{e}_1 - \omega_0 \sin \phi \vec{e}_2 + \rho \vec{e}_3] \times$$

$$[I_{11} \omega_0 \cos \phi \vec{e}_1 - I_{22} \omega_0 \sin \phi \vec{e}_2 + I_{33} \rho \vec{e}_3]$$

$$= -I_{22} \omega_0^2 \cos \phi \sin \phi \vec{e}_3 - I_{33} \rho \omega_0 \cos \phi \vec{e}_2$$

$$+ I_{11} \omega_0^2 \sin \phi \cos \phi \vec{e}_3 - I_{33} \omega_0 \rho \sin \phi \vec{e}_1$$

$$+ I_{11} \omega_0 \rho \cos \phi \vec{e}_2 + I_{22} \omega_0 \rho \sin \phi \vec{e}_1$$

- 2 -

$$\begin{aligned} \therefore \dot{\vec{h}} &= [-I_{11} \omega_0 \rho \sin \phi - I_{33} \omega_0 \rho \sin \phi + I_{22} \omega_0 \rho \sin \phi] \vec{e}_1 \\ &+ [-I_{22} \omega_0 \rho \cos \phi - I_{33} \omega_0 \rho \cos \phi + I_{11} \omega_0 \rho \cos \phi] \vec{e}_2 \\ &+ [I_{11} - I_{22}] \omega_0^2 \sin \phi \cos \phi \vec{e}_3 \end{aligned}$$

$$\begin{aligned} \text{or } \dot{\vec{h}} &= (I_{22} - I_{11} - I_{33}) \omega_0 \rho \sin \phi \vec{e}_1 \\ &+ (I_{11} - I_{22} - I_{33}) \omega_0 \rho \cos \phi \vec{e}_2 \\ &+ (I_{11} - I_{22}) \omega_0^2 \sin \phi \cos \phi \vec{e}_3 = \vec{M} \end{aligned}$$

Сопоставь то xyz!

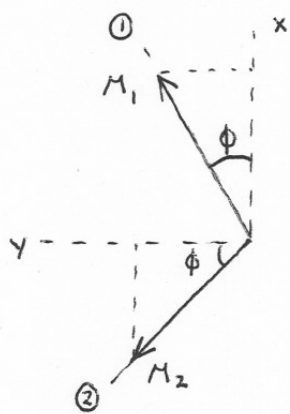

$$M_x = M_1 \cos \phi - M_2 \sin \phi$$

$$\begin{aligned} \Rightarrow M_x &= (I_{22} - I_{11} - I_{33}) \omega_0 \rho \sin \phi \cos \phi \\ &- (I_{11} - I_{22} - I_{33}) \omega_0 \rho \sin \phi \cos \phi \end{aligned}$$

$$M_x = 2(I_{22} - I_{11}) \omega_0 \rho \sin \phi \cos \phi$$

$$I_{22} - I_{11} = \frac{M}{12} (b^2 + c^2 - a^2 - b^2) = \frac{M}{12} (c^2 - a^2)$$

$$\therefore M_x = \frac{M}{6} (c^2 - a^2) \omega_0 \rho \sin \phi \cos \phi$$

## 4.12 HW 11

## 4.12.1 Problem 1

EMA 542

## Home Work to be Handed In

15) Frame SRA rotates at a constant angular velocity  $\vec{\omega}$  about the vertical  $z$  axis. Bar  $AB$  of total mass  $m$  and length  $l$  is hinged to the frame at  $A$  by a bearing which allows it to rotate in the  $SRA$  plane at an angular velocity  $\dot{\theta}$  and an angular acceleration  $\ddot{\theta}$  relative to the  $SRA$  frame. The motion of the bar  $AB$  is restrained by a massless, elastic rod  $DB$  which has an unstretched length  $a$  and a spring constant  $K = AE/a$ .

- Determine the complete rotational equation of motion of bar  $AB$  as it vibrates through small angles  $\theta$  about point  $A$  by using the relative angular momentum method and rigid body moments of inertia.
- Determine the resultant moments exerted by bearing  $A$  on bar  $AB$ .

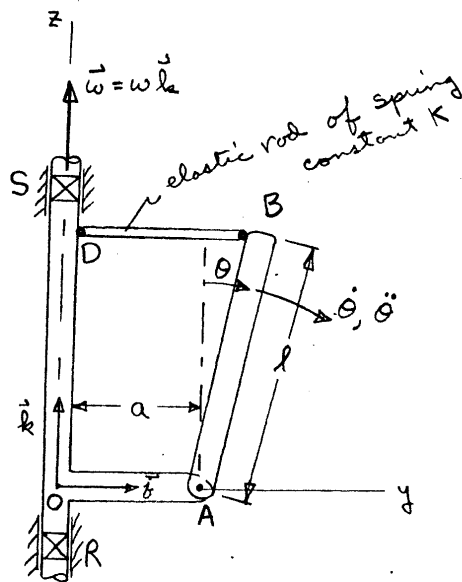

Figure 4.18: Problem description



## 4.12.1.1 Part (a)

Let  $A$  be the reference point (the point the moments will be taken about). By using a body axes which is also a principal body axes at point  $A$  we can use Euler equations for the body fixed coordinates.

The absolute angular velocity of the reference frame is  $\omega_{cs} = \omega k$  and the body absolute angular velocity is  $\Omega = \omega k - \dot{\theta}i$ . This is now written in body fixed coordinates  $e_1, e_2, e_3$ , hence

$$\Omega = \omega (\cos \theta e_3 - \sin \theta e_2) - \dot{\theta} e_1$$

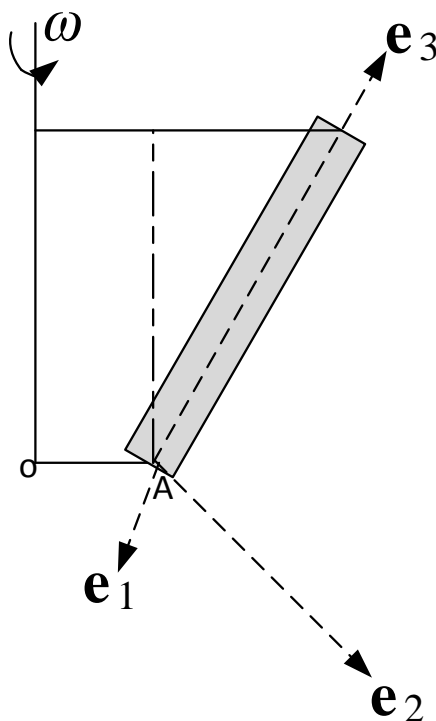

$$\begin{aligned}\Omega_1 &= -\dot{\theta} e_1 \\ \Omega_2 &= -\sin \theta e_2 \\ \Omega_3 &= \cos \theta e_3\end{aligned}$$

And

$$\begin{aligned}\dot{\Omega}_1 &= -\ddot{\theta} e_1 \\ \dot{\Omega}_2 &= -\dot{\theta} \cos \theta e_1 \\ \dot{\Omega}_3 &= -\dot{\theta} \sin \theta e_3\end{aligned}$$

And

$$\begin{aligned} I_1 &= \frac{ml^2}{3} \\ I_2 &= \frac{ml^2}{3} \\ I_3 &\sim 0 \end{aligned}$$

Hence

$$\mathbf{h}_A = \begin{pmatrix} I_1 & 0 & 0 \\ 0 & I_2 & 0 \\ 0 & 0 & I_3 \end{pmatrix} \begin{pmatrix} \Omega_1 \\ \Omega_2 \\ \Omega_3 \end{pmatrix}$$

The rate of change of the relative angular momentum of the beam using Euler equations is

$$\dot{\mathbf{h}}_A = \begin{pmatrix} \dot{h}_1 \\ \dot{h}_2 \\ \dot{h}_3 \end{pmatrix} = \begin{pmatrix} I_1 \dot{\Omega}_1 + \Omega_2 \Omega_3 (I_3 - I_2) \\ I_2 \dot{\Omega}_2 + \Omega_1 \Omega_3 (I_1 - I_3) \\ I_3 \dot{\Omega}_3 + \Omega_1 \Omega_2 (I_2 - I_1) \end{pmatrix}$$

Therefore, the moment needed to move the beam with the angular velocity specified is given by

$$\mathbf{M}_A = \dot{\mathbf{h}}_A + m\boldsymbol{\rho}_c \times \ddot{\mathbf{r}}_A$$

Where  $\boldsymbol{\rho}_c$  is a vector from  $A$  to mass center of bar given by  $\frac{l}{2}\mathbf{e}_3$  and  $\ddot{\mathbf{r}}_A$  is the absolute angular acceleration of point  $A$ . Since the  $xyz$  rotates with constant angular velocity  $\omega$ , then point  $A$  will not be accelerating in the tangential direction, but will have an acceleration inwards towards  $O$  which is  $\ddot{\mathbf{r}}_A = -a\omega^2\mathbf{j} = -a\omega^2(\sin\theta\mathbf{e}_3 + \cos\theta\mathbf{e}_2)$ , hence

$$\begin{aligned} m\boldsymbol{\rho}_c \times \ddot{\mathbf{r}}_A &= -m\frac{l}{2}\mathbf{e}_3 \times a\omega^2(\sin\theta\mathbf{e}_3 + \cos\theta\mathbf{e}_2) \\ &= -ma\omega^2\frac{l}{2}(\mathbf{e}_3 \times (\sin\theta\mathbf{e}_3 + \cos\theta\mathbf{e}_2)) \\ &= -ma\omega^2\frac{l}{2}(-\cos\theta\mathbf{e}_1) \\ &= \frac{l}{2}ma\omega^2\cos\theta\mathbf{e}_1 \end{aligned}$$

Therefore,

$$\begin{aligned} M_1 &= I_1\dot{\Omega}_1 + \Omega_2\Omega_3(I_3 - I_2) + \frac{l}{2}ma\omega^2\cos\theta \\ M_2 &= I_2\dot{\Omega}_2 + \Omega_1\Omega_3(I_1 - I_3) \\ M_3 &= I_3\dot{\Omega}_3 + \Omega_1\Omega_2(I_2 - I_1) \end{aligned}$$

Convert back to  $xyz$  using

$$\begin{aligned} M_x &= M_1 \\ M_y &= M_2\cos\theta + M_3\sin\theta \\ M_z &= M_3\cos\theta - M_2\sin\theta \end{aligned}$$

The above gives the dynamic moment, due to rotation of bar, about  $A$  expressed in  $xyz$

coordinates. They will be written in full and simplified in order to obtain the solution. Using

$$\begin{aligned}\Omega_1 &= -\dot{\theta}e_1 \\ \Omega_2 &= -\sin \theta e_2 \\ \Omega_3 &= \cos \theta e_3\end{aligned}$$

And

$$\begin{aligned}\dot{\Omega}_1 &= -\ddot{\theta}e_1 \\ \dot{\Omega}_2 &= -\dot{\theta} \cos \theta e_1 \\ \dot{\Omega}_3 &= -\dot{\theta} \sin \theta e_3\end{aligned}$$

Then, converting back to  $xyz$  coordinates

$$\begin{aligned}M_x &= I_1 \dot{\Omega}_1 + \Omega_2 \Omega_3 (I_3 - I_2) + \frac{l}{2} m a \omega^2 \cos \theta \\ &= -\frac{ml^2}{3} \ddot{\theta} - \sin \theta \cos \theta \left( 0 - \frac{ml^2}{3} \right) + \frac{l}{2} m a \omega^2 \cos \theta \\ &= -\frac{ml^2}{3} \ddot{\theta} + \frac{ml^2}{3} \sin \theta \cos \theta + \frac{l}{2} m a \omega^2 \cos \theta\end{aligned}$$

And

$$\begin{aligned}M_y &= M_2 \cos \theta + M_3 \sin \theta \\ &= \left( I_2 \dot{\Omega}_2 + \Omega_1 \Omega_3 (I_1 - I_3) \right) \cos \theta + \overbrace{\left( I_3 \dot{\Omega}_3 + \Omega_1 \Omega_2 (I_2 - I_1) \right)}^{\text{vanish}} \sin \theta \\ &= \left[ -\frac{ml^2}{3} \dot{\theta} \cos \theta - \dot{\theta} \cos \theta \left( \frac{ml^2}{3} \right) \right] \cos \theta \\ &= -\frac{ml^2}{3} \dot{\theta} \cos^2 \theta - \dot{\theta} \cos^2 \theta \left( \frac{ml^2}{3} \right) \\ &= -\frac{2}{3} ml^2 \dot{\theta} \cos^2 \theta\end{aligned}$$

And

$$\begin{aligned}M_z &= M_3 \cos \theta - M_2 \sin \theta \\ &= \overbrace{\left[ I_3 \dot{\Omega}_3 + \Omega_1 \Omega_2 (I_2 - I_1) \right]}^{\text{vanish}} \cos \theta - \left[ -\frac{ml^2}{3} \dot{\theta} \cos \theta - \dot{\theta} \cos \theta \frac{ml^2}{3} \right] \sin \theta \\ &= \frac{ml^2}{3} \dot{\theta} \cos \theta \sin \theta + \dot{\theta} \cos \theta \sin \theta \frac{ml^2}{3} \\ &= \frac{2}{3} ml^2 \dot{\theta} \cos \theta \sin \theta\end{aligned}$$

Since the problem asks to find the rotational equation of motion around  $A$  as shown, then only  $M_x$  will be used. A free body diagram is used to find the external torque around  $A$

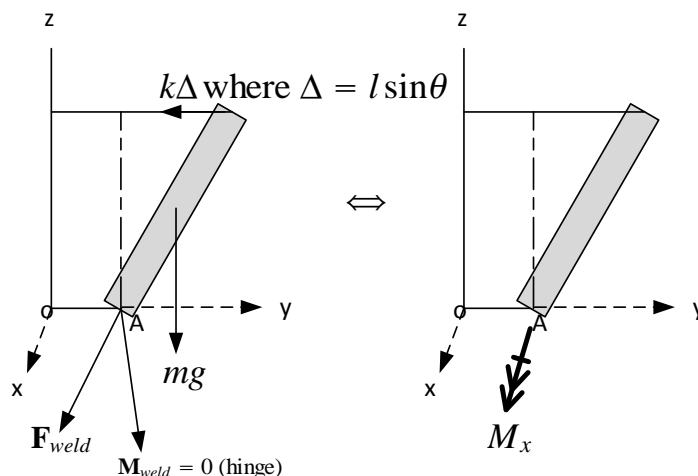

Hence

$$\begin{aligned}
 -mg \frac{l}{2} \sin \theta + kl^2 \sin \theta &= M_x \\
 -mg \frac{l}{2} \sin \theta + kl^2 \sin \theta &= -\frac{ml^2}{3} \ddot{\theta} + \frac{ml^2}{3} \sin \theta \cos \theta + \frac{l}{2} ma\omega^2 \cos \theta
 \end{aligned}$$

For small angle  $\sin \theta \rightarrow \theta$  and  $\cos \theta \rightarrow 1$ , hence

$$\begin{aligned}
 -mg \frac{l}{2} \theta + kl^2 \theta &= -\frac{ml^2}{3} \ddot{\theta} + \frac{ml^2}{3} \theta + \frac{l}{2} ma\omega^2 \\
 \frac{ml^2}{3} \ddot{\theta} - \frac{ml^2}{3} \theta - mg \frac{l}{2} \theta + kl^2 \theta &= \frac{l}{2} ma\omega^2 \\
 \frac{ml^2}{3} \ddot{\theta} + \left( kl^2 - \frac{ml^2}{3} - mg \frac{l}{2} \right) \theta &= \frac{l}{2} ma\omega^2 \\
 \ddot{\theta} + \left( \frac{3k}{m} - 1 - \frac{3g}{2l} \right) \theta &= \frac{l}{2} ma\omega^2
 \end{aligned}$$

This is the equation of motion for rotation for small angles.

#### 4.12.1.2 Part(b)

We need to find  $F_{weld}$ , which represent reaction at the hinge A. Balance of external forces at A gives

$$F_{weld} - mg\mathbf{k} - kl \sin \theta \mathbf{j} = m\mathbf{a}_{cg}$$

Where  $\mathbf{a}_{cg}$  is the acceleration of center of mass of bar. Using

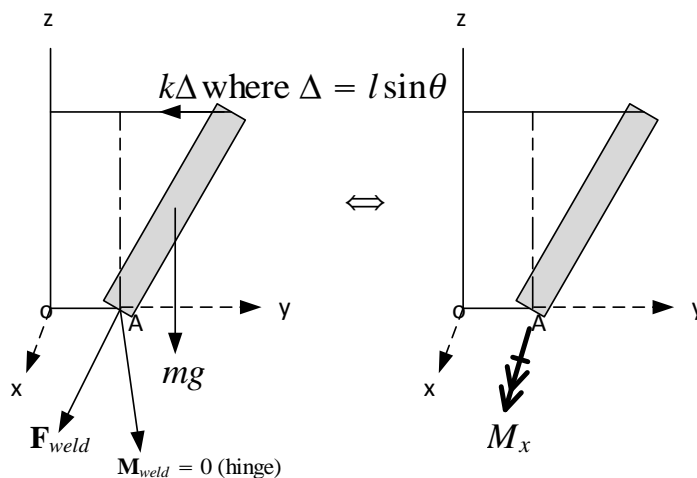

$$\rho = \left(a + \frac{l}{2} \sin \theta\right) \mathbf{j} + \frac{l}{2} \cos \theta \mathbf{k}$$

$$\dot{\rho}_r = \left(\frac{l}{2} \dot{\theta} \cos \theta\right) \mathbf{j} - \frac{l}{2} \dot{\theta} \sin \theta \mathbf{k}$$

$$\ddot{\rho}_r = \frac{l}{2} (\ddot{\theta} \cos \theta - \dot{\theta}^2 \sin \theta) \mathbf{j} - \frac{l}{2} (\ddot{\theta} \sin \theta + \dot{\theta}^2 \cos \theta) \mathbf{k}$$

$$\omega = \omega \mathbf{k}$$

$$\dot{\omega} = \dot{\omega} \mathbf{k}$$

$$\omega \times \dot{\rho}_r = \omega \mathbf{k} \times \left[ \left(\frac{l}{2} \dot{\theta} \cos \theta\right) \mathbf{j} - \frac{l}{2} \dot{\theta} \sin \theta \mathbf{k} \right]$$

$$= -\omega \frac{l}{2} \dot{\theta} \cos \theta \mathbf{i}$$

$$\dot{\omega} \times \rho = \dot{\omega} \mathbf{k} \times \left[ \left(a + \frac{l}{2} \sin \theta\right) \mathbf{j} + \frac{l}{2} \cos \theta \mathbf{k} \right]$$

$$= -\dot{\omega} \left(a + \frac{l}{2} \sin \theta\right) \mathbf{i}$$

$$\omega \times \rho = -\omega \left(a + \frac{l}{2} \sin \theta\right) \mathbf{i}$$

$$\omega \times (\omega \times \rho) = \omega \mathbf{k} \times -\left(\omega \left(a + \frac{l}{2} \sin \theta\right) \mathbf{i}\right)$$

$$= -\omega^2 \left(a + \frac{l}{2} \sin \theta\right) \mathbf{j}$$

$$\ddot{\mathbf{R}} = 0$$

Hence

$$\begin{aligned} \mathbf{a}_{cg} &= \ddot{\mathbf{R}} + \ddot{\rho}_r + 2(\omega \times \dot{\rho}_r) + \dot{\omega} \times \rho + \omega \times (\omega \times \rho) \\ &= \frac{l}{2}(\ddot{\theta} \cos \theta - \dot{\theta}^2 \sin \theta) \mathbf{j} - \frac{l}{2}(\ddot{\theta} \sin \theta + \dot{\theta}^2 \cos \theta) \mathbf{k} \\ &\quad + 2\left(-\omega \frac{l}{2} \dot{\theta} \cos \theta \mathbf{i}\right) - \dot{\omega} \left(a + \frac{l}{2} \sin \theta\right) \mathbf{i} - \omega^2 \left(a + \frac{l}{2} \sin \theta\right) \mathbf{j} \end{aligned}$$

Hence

$$\begin{aligned} \mathbf{a}_{cg} &= \ddot{\mathbf{R}} + \ddot{\rho}_r + 2(\omega \times \dot{\rho}_r) + \dot{\omega} \times \rho + \omega \times (\omega \times \rho) \\ &= \mathbf{i} \left(-\omega l \dot{\theta} \cos \theta - \dot{\omega} \left(a + \frac{l}{2} \sin \theta\right)\right) \\ &\quad + \mathbf{j} \left(\frac{l}{2}(\ddot{\theta} \cos \theta - \dot{\theta}^2 \sin \theta) - \omega^2 \left(a + \frac{l}{2} \sin \theta\right)\right) \\ &\quad - \frac{l}{2}(\ddot{\theta} \sin \theta + \dot{\theta}^2 \cos \theta) \mathbf{k} \end{aligned}$$

Hence from

$$\mathbf{F}_{weld} - mg\mathbf{k} - kl \sin \theta \mathbf{j} = m\mathbf{a}_{cg}$$

We can find  $F_{weld}$

$$\begin{aligned} F_z &= mg - m\frac{l}{2}(\ddot{\theta} \sin \theta + \dot{\theta}^2 \cos \theta) \\ F_y &= kl \sin \theta + m\frac{l}{2}(\ddot{\theta} \cos \theta - \dot{\theta}^2 \sin \theta) - m\omega^2 \left(a + \frac{l}{2} \sin \theta\right) \\ F_x &= -m\omega l \dot{\theta} \cos \theta - m\dot{\omega} \left(a + \frac{l}{2} \sin \theta\right) \end{aligned}$$

For small angle

$$\begin{aligned} F_z &= mg - m\frac{l}{2}(\ddot{\theta} + \dot{\theta}^2) \\ F_y &= kl\theta + m\frac{l}{2}(\ddot{\theta} - \dot{\theta}^2\theta) - m\omega^2 \left(a + \frac{l}{2}\theta\right) \\ F_x &= -m\omega l \dot{\theta} - m\dot{\omega} \left(a + \frac{l}{2}\theta\right) \end{aligned}$$

Sometimes  $\dot{\theta}^2$  can be approximated to zero for small angle. If this is allowed, then the above simplifies to

$$\begin{aligned} F_z &= mg - m\frac{l}{2}\ddot{\theta} \\ F_y &= kl\theta + m\frac{l}{2}\ddot{\theta} - m\omega^2 \left(a + \frac{l}{2}\theta\right) \\ F_x &= -m\omega l \dot{\theta} - m\dot{\omega} \left(a + \frac{l}{2}\theta\right) \end{aligned}$$

Since  $\ddot{\theta}$  has been found above, all reactions at joint  $A$  can now be found.

4.12.2 Problem 2

13

EM 542

Turntable A rotates at constant angular velocity  $N$  about the vertical  $z$  axis and the  $x, y, z$  axes are attached to the turntable. The slender rod of mass  $m$  and length  $l$  is forced to rotate at constant angular velocity  $n$  about axis 3 relative to the platform. [a] Determine the resultant moment  $\vec{M}_C$  that must be applied to the system at point  $C$  in order to sustain this motion. Give your answer in terms of components along axes  $x', y', z'$  (i.e.,  $\vec{M}_C = M_{x'}\vec{i}' + M_{y'}\vec{j}' + M_{z'}\vec{k}'$ ). [b] Determine the vertical components of the bearing reactions acting on the shaft at  $B$  and  $D$  and clearly show the direction of your answers on the sketch below.

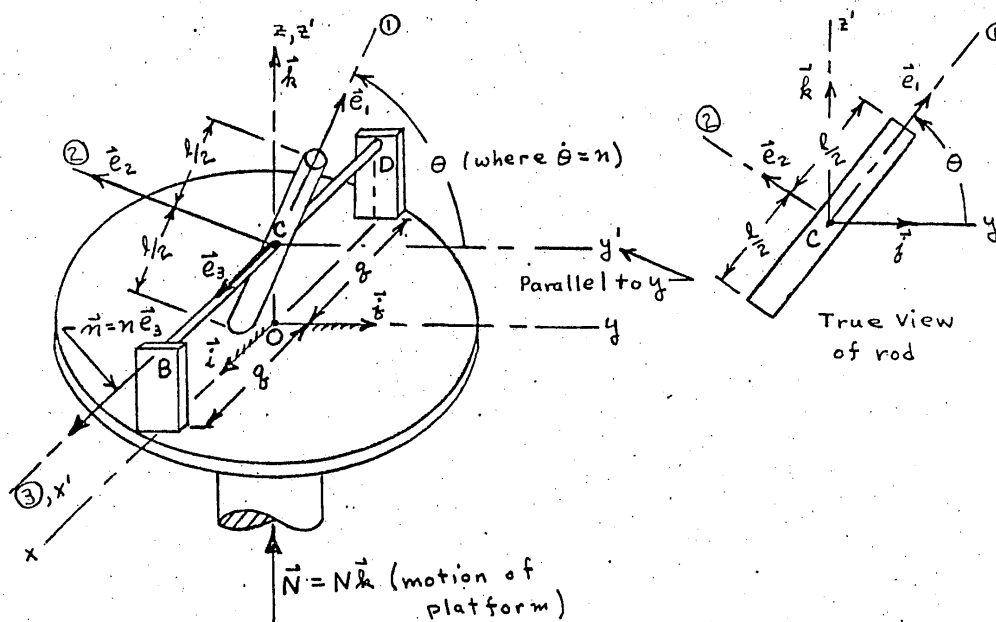

4.12.2.1 Part (a)

Let  $C$  be the reference point (the point the moments will be taken about). It is also the center of mass of the rod.

The absolute angular velocity of the reference frame is  $\omega_{cs} = N\vec{k}$  and the body absolute angular velocity is  $\Omega = N\vec{k} + \dot{\theta}\vec{i}$ . This is now written in body fixed coordinates  $e_1, e_2, e_3$ , hence

$$\Omega = N(\sin \theta \vec{e}_1 + \cos \theta \vec{e}_2) + \dot{\theta} \vec{e}_3$$

Therefore

$$\Omega_1 = N \sin \theta$$

$$\Omega_2 = N \cos \theta$$

$$\Omega_3 = \dot{\theta}$$

And

$$\begin{aligned}\dot{\Omega}_1 &= N\dot{\theta} \cos \theta \\ \dot{\Omega}_2 &= -N\dot{\theta} \sin \theta \\ \dot{\Omega}_3 &= \ddot{\theta} = 0\end{aligned}$$

And

$$\begin{aligned}I_1 &\sim 0 \\ I_2 &= \frac{ml^2}{12} \\ I_3 &= \frac{ml^2}{12}\end{aligned}$$

Hence

$$\mathbf{h}_c = \begin{pmatrix} I_1 & 0 & 0 \\ 0 & I_2 & 0 \\ 0 & 0 & I_3 \end{pmatrix} \begin{pmatrix} \Omega_1 \\ \Omega_2 \\ \Omega_3 \end{pmatrix}$$

The rate of change of the relative angular momentum of the beam using Euler equations is

$$\dot{\mathbf{h}}_c = \begin{pmatrix} \dot{h}_1 \\ \dot{h}_2 \\ \dot{h}_3 \end{pmatrix} = \begin{pmatrix} I_1\dot{\Omega}_1 + \Omega_2\Omega_3(I_3 - I_2) \\ I_2\dot{\Omega}_2 + \Omega_1\Omega_3(I_1 - I_3) \\ I_3\dot{\Omega}_3 + \Omega_1\Omega_2(I_2 - I_1) \end{pmatrix}$$

Therefore, the moment needed to move the beam with the angular velocity specified is given by

$$\mathbf{M}_c = \dot{\mathbf{h}}_c + m\boldsymbol{\rho}_c \times \ddot{\mathbf{r}}_c$$

Since the reference point is at the mass center of the rotating body, then  $\boldsymbol{\rho}_c = 0$ . Therefore,

$$\begin{aligned}M_1 &= I_1\dot{\Omega}_1 + \Omega_2\Omega_3(I_3 - I_2) \\ M_2 &= I_2\dot{\Omega}_2 + \Omega_1\Omega_3(I_1 - I_3) \\ M_3 &= I_3\dot{\Omega}_3 + \Omega_1\Omega_2(I_2 - I_1)\end{aligned}$$

Convert back to  $x'y'z'$  using

$$\begin{aligned}M_{x'} &= M_3 \\ M_{y'} &= M_1 \cos \theta - M_2 \sin \theta \\ M_{z'} &= M_1 \sin \theta + M_2 \cos \theta\end{aligned}$$



Hence

$$\begin{aligned} M_{x'} &= I_3 \dot{\Omega}_3 + \Omega_1 \Omega_2 (I_2 - I_1) \\ &= N^2 \sin \theta \cos \theta \frac{ml^2}{12} \end{aligned}$$

$$\begin{aligned} M_{y'} &= M_1 \cos \theta - M_2 \sin \theta \\ &= \overbrace{[I_1 \dot{\Omega}_1 + \Omega_2 \Omega_3 (I_3 - I_2)]}^{\text{vanish}} \cos \theta - [I_2 \dot{\Omega}_2 + \Omega_1 \Omega_3 (I_1 - I_3)] \sin \theta \\ &= - \left[ -\frac{ml^2}{12} N \dot{\theta} \sin \theta + \dot{\theta} N \sin \theta \left( 0 - \frac{ml^2}{12} \right) \right] \sin \theta \\ &= \frac{ml^2}{12} N \dot{\theta} \sin^2 \theta + \dot{\theta} N \sin^2 \theta \frac{ml^2}{12} \\ &= \frac{ml^2}{6} N \dot{\theta} \sin^2 \theta \end{aligned}$$

$$\begin{aligned} M_{z'} &= M_1 \sin \theta + M_2 \cos \theta \\ &= [I_1 \dot{\Omega}_1 + \Omega_2 \Omega_3 (I_3 - I_2)] \sin \theta + [I_2 \dot{\Omega}_2 + \Omega_1 \Omega_3 (I_1 - I_3)] \cos \theta \\ &= \dot{\theta} N \cos \theta \sin \theta \left( \frac{ml^2}{12} \right) + \left[ -\frac{ml^2}{12} N \dot{\theta} \sin \theta + \dot{\theta} N \sin \theta \left( 0 - \frac{ml^2}{12} \right) \right] \cos \theta \\ &= \dot{\theta} N \cos \theta \sin \theta \left( \frac{ml^2}{12} \right) - \frac{ml^2}{12} N \dot{\theta} \sin \theta \cos \theta - \dot{\theta} N \sin \theta \cos \theta \frac{ml^2}{12} \\ &= -\frac{ml^2}{12} N \dot{\theta} \sin \theta \cos \theta \end{aligned}$$

The above is the components of the resultant moment at  $C$  to sustain this motion.

#### 4.12.2.2 Part(b)

The bar's center of mass does not move in space. Hence there is no linear acceleration associated with the bar translation. Therefore, we can set up the free body diagram now and solve for the reactions as follows

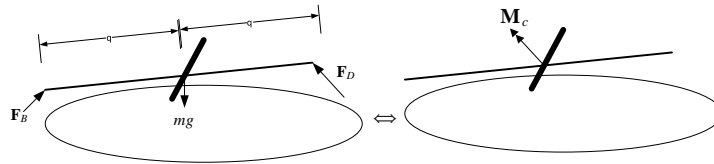

Dynamic loads balance with external forces

To find  $F_B$ , Taking moments at  $D$

$$\begin{aligned} -2qi \times F_B + (-qi) \times (-mgk) &= M_c \\ -2qi \times (F_x i + F_y j + F_z k) - mgqj &= M_c \\ k(-2qF_y) - j(-2qF_z) - mgqj &= M_c \\ -2qF_y k + 2qF_z j - mgqj &= M_c \end{aligned}$$

For vertical reactions only, hence need to find  $F_z$

$$\begin{aligned} 2qF_z - mgq &= \frac{ml^2}{6} N \dot{\theta} \sin^2 \theta \\ 2qF_z &= \frac{ml^2}{6} N \dot{\theta} \sin^2 \theta + mgq \\ F_z &= \frac{ml^2}{12q} N \dot{\theta} \sin^2 \theta + \frac{mg}{2} \end{aligned}$$

The force in the bearing  $F_z$  is positive at  $B$ . hence upwards.

To find  $F_z$  at  $D$ . taking moments at  $B$

$$\begin{aligned} 2qi \times F_D + (qi) \times (-mgk) &= M_c \\ 2qi \times (F_x i + F_y j + F_z k) + mgqj &= M_c \\ k(2qF_y) - j(2qF_z) + mgqj &= M_c \\ 2qF_y k - 2qF_z j + mgqj &= M_c \end{aligned}$$

For vertical reactions only, hence need to find  $F_z$

$$\begin{aligned} -2qF_z + mgq &= \frac{ml^2}{6} N \dot{\theta} \sin^2 \theta \\ -2qF_z &= \frac{ml^2}{6} N \dot{\theta} \sin^2 \theta - mgq \\ F_z &= -\frac{ml^2}{12q} N \dot{\theta} \sin^2 \theta + \frac{mg}{2} \end{aligned}$$

The force in the bearing  $F_z$  when  $t = 0$  is positive. but it can become negative. It depends if

$\frac{ml^2}{12q} N \dot{\theta} \sin^2 \theta$  is bigger or smaller than  $\frac{mg}{2}$

4.12.3 key solution

13

EM 542

Turntable A rotates at constant angular velocity  $N$  about the vertical  $z$  axis and the  $x, y, z$  axes are attached to the turntable. The slender rod of mass  $m$  and length  $\ell$  is forced to rotate at constant angular velocity  $n$  about axis 3 relative to the platform. [a] Determine the resultant moment  $\vec{M}_C$  that must be applied to the system at point C in order to sustain this motion. Give your answer in terms of components along axes  $x', y', z'$  (i.e.,  $\vec{M}_C = M_{x'}\vec{i}' + M_{y'}\vec{j}' + M_{z'}\vec{k}'$ ). [b] Determine the vertical components of the bearing reactions acting on the shaft at B and D and clearly show the direction of your answers on the sketch below.

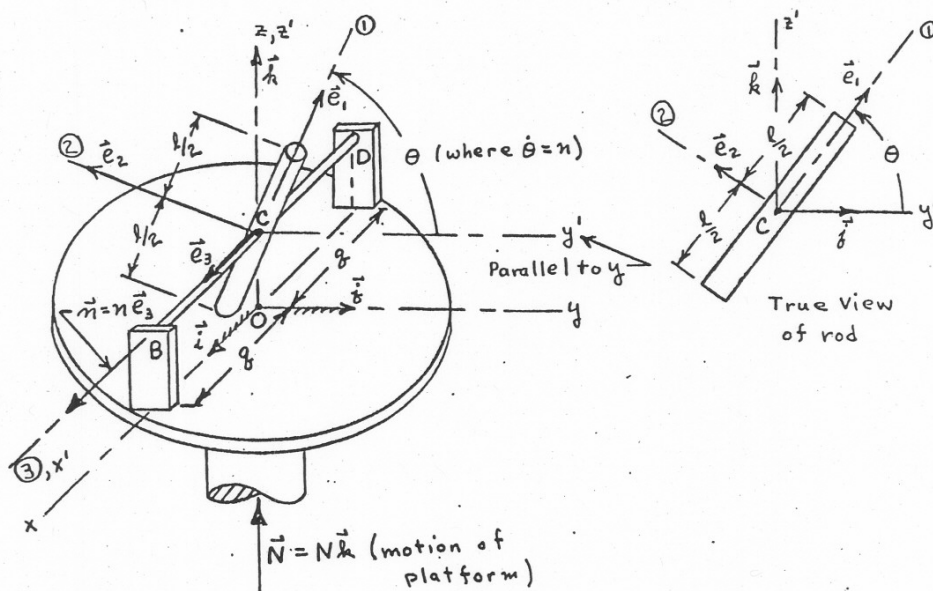

solution

	$\omega_1 = N \sin \theta$	$\dot{\omega}_1 = N n \cos \theta$	$I_1 = 0$	③
⑥	$\omega_2 = N \cos \theta$	$\dot{\omega}_2 = -N n \sin \theta$	$I_2 = \frac{1}{12} m l^2$	③
④	$\omega_3 = n$	$\dot{\omega}_3 = 0$	$I_3 = \frac{1}{12} m l^2$	③

$$(a) M_1^{(5)} = I_1 \dot{\omega}_1 + \omega_2 \omega_3 (I_3 - I_2) = 0$$

$$b) M_2^{(5)} = I_2 \dot{\omega}_2 + \omega_1 \omega_3 (I_1 - I_3) = -\frac{1}{12} m l^2 N n \sin \theta + N n \sin \theta (-\frac{1}{12} m l^2)$$

$$\therefore M_2 = -\frac{1}{6} m l^2 N n \sin \theta$$

$$c) M_3^{(5)} = I_3 \dot{\omega}_3 + \omega_1 \omega_2 (I_2 - I_1) = N^2 \sin \theta \cos \theta (\frac{1}{12} m l^2)$$

$$\therefore M_3 = \frac{1}{12} m l^2 N^2 \sin \theta \cos \theta$$

$$\textcircled{5} \left\{ M_1 = M_3 = \frac{1}{12} m l^2 N^2 \sin \theta \cos \theta$$

$$\textcircled{6} \left\{ M_y = M_1 \cos \theta - M_2 \sin \theta = +\frac{1}{6} m l^2 N n \sin^2 \theta$$

$$\textcircled{6} \left\{ M_z = M_1 \sin \theta + M_2 \cos \theta = -\frac{1}{6} m l^2 N n \sin \theta \cos \theta$$

b)

$$(a) B_z + D_z \stackrel{-Mg}{=} 0 \quad \textcircled{5}$$

$$B_z = -D_z + Mg$$

$$D_z(q) - B_z(q) = M_y = \frac{1}{6} m l^2 N n \sin^2 \theta \quad \textcircled{6}$$

$$\therefore D_z(2q) = \frac{1}{6} m l^2 N n \sin^2 \theta + Mg q$$

$$D_z = -B_z = \frac{1}{12} \frac{m l^2}{q} N n \sin^2 \theta + \frac{1}{2} Mg \quad \textcircled{2}$$

$$B_z = \frac{1}{2} Mg - \frac{1}{12} M \frac{l^2}{q} N n \sin^2 \theta \quad \textcircled{2}$$

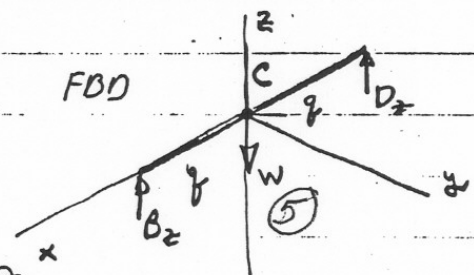

EMA 542

Home Work to be Handed In

15) Frame SRA rotates at a constant angular velocity  $\vec{\omega}$  about the vertical  $z$  axis. Bar AB of total mass  $m$  and length  $l$  is hinged to the frame at A by a bearing which allows it to rotate in the SRA plane at an angular velocity  $\dot{\theta}$  and an angular acceleration  $\ddot{\theta}$  relative to the SRA frame. The motion of the bar AB is restrained by a massless, elastic rod DB which has an unstretched length  $a$  and a spring constant  $K = AE/a$ .

- a. Determine the complete rotational equation of motion of bar AB as it vibrates through small angles  $\theta$  about point A by using the relative angular momentum method and rigid body moments of inertia.
- b. Determine the resultant moments exerted by bearing A on bar AB.

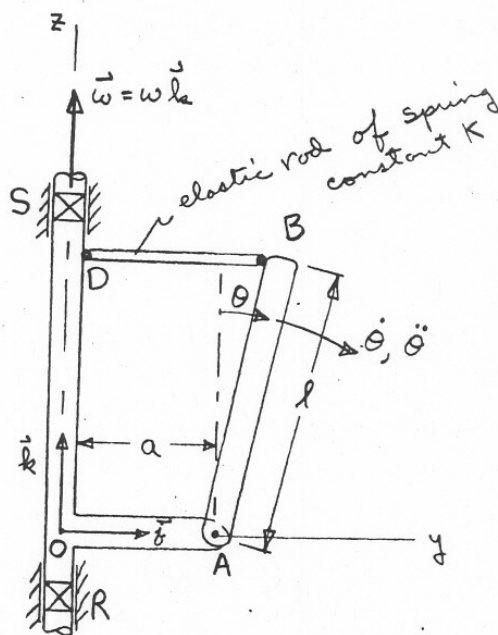

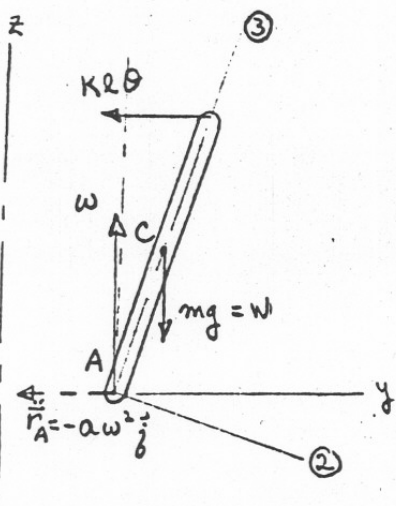

$$\begin{aligned} \omega_1 &= -\dot{\theta} & \dot{\omega}_1 &= -\ddot{\theta} & I_1 &= \frac{1}{3} m l^2 \\ \omega_2 &= -\omega \sin \theta & \dot{\omega}_2 &= -\omega \dot{\theta} \cos \theta & I_2 &= \frac{1}{3} m l^2 \\ \omega_3 &= \omega \cos \theta & \dot{\omega}_3 &= -\omega \dot{\theta} \sin \theta & I_3 &= 0 \end{aligned}$$

[ Must Use Eqs. (k) since point A is a moving point ]

$$\begin{aligned} \therefore M_1 &= I_1 \dot{\omega}_1 + \omega_2 \omega_3 (I_3 - I_2) + m \left\{ 0 - \left( \frac{l}{2} \right) (-a \omega^2 \cos \theta) \right\} \\ &= -\frac{1}{3} m l^2 \ddot{\theta} + (-\omega \sin \theta)(\omega \cos \theta) \left[ 0 - \frac{1}{3} m l^2 \right] + m \frac{l}{2} a \omega^2 \cos \theta \end{aligned}$$

$$\therefore M_1 = -\frac{1}{3} m l^2 \ddot{\theta} + \frac{1}{3} m l^2 \omega^2 \sin \theta \cos \theta + \frac{1}{2} m l a \omega^2 \cos \theta$$

Since the external moments about axis  $\hat{O}$  are given by <sup>for small angles</sup>

$$M_1 \approx +K l^2 \theta - m g \frac{l}{2} \theta$$

we have for small angle:

$$K l^2 \theta - m g \frac{l}{2} \theta = -\frac{1}{3} m l^2 \ddot{\theta} + \frac{1}{3} m l^2 \omega^2 \theta + \frac{1}{2} m l a \omega^2$$

$$\therefore \frac{1}{3} m l \ddot{\theta} + \left[ K l - \frac{m g}{2} - \frac{1}{3} m l \omega^2 \right] \theta = \frac{1}{2} m a \omega^2 \quad \checkmark$$

②

$$M_2 = I_2 \dot{\omega}_2 + \omega_1 \omega_3 (I_1 - I_3) + m(0 - 0) \\ = -\frac{1}{3} m l^2 \dot{\omega} \cos \theta + (-\dot{\theta})(\omega \cos \theta) \left( \frac{1}{3} m l^2 - 0 \right)$$

$$M_2 = -\frac{2}{3} m l^2 \dot{\omega} \cos \theta$$

$$M_3 = 0 = I_3 \dot{\omega}_3 + \omega_1 \omega_2 (I_2 - I_1) + m(0 - 0) \\ \uparrow \quad \uparrow y_c = 0 \text{ for axis } \textcircled{2} \\ x_c = 0 \text{ for axis } \textcircled{1}$$