

University Course

MATH 121B
Mathematical Tools for the Physical
Sciences

UC BERKELEY
Spring 2004

My Class Notes

Nasser M. Abbasi

Spring 2004

Contents

1	Introduction	1
1.1	A bit about UC Berkeley	2
1.2	Textbook	2
1.3	Course description	3
2	Study notes	5
2.1	cheat sheets	6
3	Exams	11
3.1	First exam	12
3.2	Second exam	13
3.3	Final exam	14
4	HWs	17
4.1	HW 1	18
4.2	HW 2	33
4.3	HW 3	54
4.4	HW 4	82
4.5	HW 5	103
4.6	HW 6	125
4.7	HW 7	153
4.8	HW 8	191
4.9	HW 9	228
4.10	HW 10	260
4.11	HW 11	283
4.12	HW 12	296

Chapter 1

Introduction

Local contents

- 1.1 A bit about UC Berkeley 2
- 1.2 Textbook 2
- 1.3 Course description 3

This is my web page for course MATH 121 B, Mathematical methods in physical sciences, that I took in spring 2004 at UC Berkeley.

Instructor: Prof. Richard E. Borcherds UC Berkeley Math department. Personal Homepage <http://math.berkeley.edu/reb/>

1.1 A bit about UC Berkeley

This below is a picture of Evans hall. It is a big tall building full of very smart people. The math department is on the 9th floor. The course was in room 3, which is on the ground floor on Evans hall



1.2 Textbook

MATHEMATICAL METHODS IN PHYSICAL SCI, BOAS. 2nd edition chapters 11, 12, 13, and 16

Textbook was Mary Boas, second edition. This seems to be the standard book for these type of course are most universities, at least the ones I know about. It is a good book, but more detailed examples would have been nice. So another book such as the problem solvers type books might be useful to have.

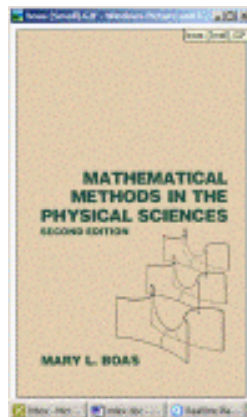

1.3 Course description

Spring 2004 (January-May 2004) Course description: Functions of a complex variable, Fourier series, finite-dimensional linear systems. Infinite-dimensional linear systems, orthogonal expansions, special functions, partial differential equations arising in mathematical physics. Intended for students in the physical sciences who are not planning to take more advanced mathematics courses.

Units: 4

Chapter 2

Study notes

Local contents

2.1 cheat sheets 6

2.1 cheat sheets

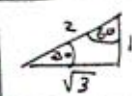
$\frac{d}{dx} \ln x = \frac{1}{x}$	$\frac{d}{dx} e^{ax} = ae^{ax}$	$\int \ln(x) = -x + x \ln(x)$	$\frac{d}{dx} \sin x = \cos x$	$\frac{d}{dx} \cos x = -\sin x$
$ax^2 + bx + c = 0 \Rightarrow x = \frac{-b \pm \sqrt{b^2 - 4ac}}{2a}$	$e^{x \ln(a)} = (e^{\ln(a)})^x = a^x$	$\log_a x = \frac{\ln(x)}{\ln(a)}$		
$\frac{d}{dx} \ln \frac{1}{x} = -\frac{1}{x}$	$\sin 2\alpha = 2 \sin \alpha \cos \alpha$ $\cos 2\alpha = 2 \cos^2 \alpha - 1$	$\sin x = x - \frac{x^3}{3!} + \dots$ $\cos x = 1 - \frac{x^2}{2!} + \dots$	$e^x = 1 + x + \frac{x^2}{2!} + \frac{x^3}{3!} + \dots$	$\log x^y = y \log x$
$\int e^{at} = \frac{1}{a} e^{at}$	$(\frac{u}{v})' = \frac{u'v - uv'}{v^2}$	$(uv)' = uv' + vu'$		
$A = \pi r^2$ $C = 2\pi r$	$\frac{A_1}{A} = \frac{\phi}{360}$ <small>circle area</small>	$\frac{ds}{\phi} = \frac{2\pi r}{360}$ <small>ds = r dφ in radians</small>	$\frac{x^2}{a^2} + \frac{y^2}{b^2} = 1$	
$\sin^2 \phi = \frac{1 - \cos 2\phi}{2}$	Incomplete $\Gamma(n, x) = \frac{x^{n-1}}{e^x} (1 + \frac{n-1}{x} + \frac{(n-1)(n-2)}{x^2} + \dots)$ Put $n = \frac{1}{2}$, $x = y^2$ to get $\operatorname{erf}(x) = 1 - \frac{\Gamma(\frac{1}{2}, x^2)}{\sqrt{\pi}}$		$(1 \pm x)^{\frac{1}{2}} = 1 \mp \frac{1}{2}x + \frac{1 \cdot 3}{2 \cdot 4}x^2 - \frac{1 \cdot 3 \cdot 5}{2 \cdot 4 \cdot 6}x^3$ $(1 \pm x)^{-\frac{1}{2}} = 1 \pm \frac{1}{2}x - \frac{1 \cdot 1}{2 \cdot 4}x^2 + \frac{1 \cdot 1 \cdot 3}{2 \cdot 4 \cdot 6}x^3$	
$\log(xy) = \log x + \log y$ $\log x^n = n \log x$ $\log \frac{x}{y} = \log x - \log y$	$e = \lim_{n \rightarrow \infty} (1 + \frac{1}{n})^n$	$\int \cos 2x dx = \frac{1}{2} \sin 2x$ $\int \sin 2x dx = -\frac{1}{2} \cos 2x$		
Legendre DE: $(1-x^2)y'' - 2xy' + l(l+1)y = 0$		$\int_{-1}^1 P_l P_m = 0$		
non product $\int_{-1}^1 f(x) P_n(x) dx = \frac{2}{2n+1} a_n$	$\tilde{f}(x) = a_0 P_0 + a_1 P_1 + \dots$			
$\int_{-1}^1 f(x) f(x) = N^2 \leftarrow \text{norm}$	so normalized with function = $\frac{f(x)}{\sqrt{N^2}}$			
$\int_0^\infty e^{-ax} dx = -\frac{1}{a} e^{-ax} \Big _0^\infty = \frac{1}{a}$	$\frac{d}{dx} \ln(f(x)g(x)) = \frac{g(x)f'(x) + f(x)g'(x)}{f(x)g(x)}$			
$X = \int \tilde{f}(x)$ \downarrow $\frac{d}{dx} X = \tilde{f}(x)$	$\nabla^2 u = 0$ $\begin{cases} \sin kx e^{ky} \\ \sin kx e^{-ky} \\ \cos kx e^{ky} \\ \cos kx e^{-ky} \end{cases}$	$\Gamma(n) = (n-1)!$ $u = \sum b_n \sin \frac{n\pi}{L} x$		
$\nabla^2 u = \frac{1}{x^2} \frac{\partial u}{\partial x}$	$\nabla^2 u = 0$ with $\nabla^2 u = 0$ for $x > 0$ has solution $u = \sum b_n$	$\Rightarrow b_n = \frac{2}{L} \int_0^L f(x) \sin \frac{n\pi}{L} x$		

$\int_0^\infty x^n e^{-ax} = \frac{n!}{a^{n+1}} \rightarrow \int_0^\infty x^n e^{-x} = n!$ $\xrightarrow{n \text{ noninteger}}$ $\int_0^\infty x^{p-1} e^{-x} = \Gamma(p), p > 0$

$\Gamma(n) = (n-1)!$ ex: $\Gamma(5) = 4!$ $\Gamma(n+1) = n!$ $\Gamma(p+1) = p\Gamma(p)$ $\Gamma(p) = \frac{1}{p} \Gamma(p+1)$ $\Gamma(-0.5) = \frac{1}{-0.5} \Gamma(0.5)$

$\Gamma(p) = \infty$ For $p = -1, -2, -3, \dots$ $\Gamma(p) \neq \infty$ at 0 $\Gamma(\frac{1}{2}) = \int_0^\infty x^{\frac{1}{2}-1} e^{-x} = \int_0^\infty \frac{1}{\sqrt{x}} e^{-x} = \sqrt{\pi}$ special: $\int_0^\infty e^{-t^2} = \frac{1}{2} \Gamma(\frac{1}{2})$ $\Gamma(p)\Gamma(1-p) = \frac{\pi}{\sin \pi p}$

$B(p, q) = \int_0^1 x^{p-1} (1-x)^{q-1} dx$ $p > 0, q > 0$ $B(p, q) = B(q, p)$ $B(p, q) = 2 \int_0^{\pi/2} (\sin \theta)^{2p-1} (\cos \theta)^{2q-1} d\theta$

$B(p, q) = \frac{\Gamma(p)\Gamma(q)}{\Gamma(p+q)}$ $B(p, q) = \int_0^\infty \frac{y^{p-1}}{(1+y)^{p+q}} dy$ $\int_0^\infty \frac{x^{p-1}}{(1+x)^{p+q}} dx$ used to solve $\int_0^\infty \frac{x^3}{(1+x)^5} dx$ type integrals

$\text{erf}(x) = \frac{2}{\sqrt{\pi}} \int_0^x e^{-t^2} dt$ factor comes out to be 1 $P(-\infty, x) = \frac{1}{\sqrt{2\pi}} \int_{-\infty}^x e^{-t^2/2} dt = \frac{1}{2} + \frac{1}{2} \text{erf}\left(\frac{x}{\sqrt{2}}\right)$

$P(0, x) = \frac{1}{\sqrt{2\pi}} \int_0^x e^{-t^2/2} = \frac{1}{2} \text{erf}\left(\frac{x}{\sqrt{2}}\right)$ $\text{erfc}(x) = \frac{2}{\sqrt{\pi}} \int_x^\infty e^{-t^2} = 1 - \text{erf}(x)$

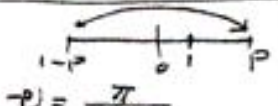
 $\Gamma(p)\Gamma(1-p) = \frac{\pi}{\sin \pi p}$ $P\Gamma(p) = \Gamma(p+1)$ $\text{erf}(\infty) = 1$ since $\int_{-\infty}^\infty e^{-x^2} = \sqrt{\pi}$ This area = $\frac{\text{erf}(x) \sqrt{\pi}}{2}$ This area = $1 - \text{erf}(x)$

Series approx
 $n! = n^n e^{-n} \sqrt{2\pi n}$

Legendre form: $F(k, \phi) = \int_0^\phi \frac{d\theta}{\sqrt{1-k^2 \sin^2 \theta}}$, $E(k, \phi) = \int_0^\phi \sqrt{1-k^2 \sin^2 \theta} d\theta$ $k = \sin \theta$

Complete: $F(k, \pi/2) = \int_0^{\pi/2} \frac{d\theta}{\sqrt{1-k^2 \sin^2 \theta}}$, $E(k, \pi/2) = \int_0^{\pi/2} \sqrt{1-k^2 \sin^2 \theta} d\theta$

Jacobi form: $F(k, x) = \int_0^x \frac{dx}{\sqrt{(1-x^2)(1-k^2 x^2)}}$, $E(k, x) = \int_0^x \sqrt{\frac{1-k^2 x^2}{1-x^2}} dx$

$\Phi(x, h) = (1-2xh+h^2)^{1/2}$
 expand in power series. $\Phi(x, h) \rightarrow P_0 + h P_1 + h^2 P_2 + \dots$

Associated Legendre:
 $P_n^m = (1-x^2)^{m/2} \frac{d^m}{dx^m} P_n$

Legendre polynomials:
 $\int_{-1}^1 P_n P_m = \frac{2}{2n+1}$

$f(x), g(x)$ are orthogonal on (a, b) if $\int_a^b f(x)g(x) dx = 0$.

$\int_{-\pi}^{\pi} \sin nx \sin mx = \begin{cases} 0 & m \neq n \\ \pi & m = n \neq 0 \end{cases}$

$\int_{-\pi}^{\pi} \sin nx \cos mx = 0$ for any n, m

$\int_{-1}^1 P_n P_m = 0$ $m \neq n$.
 $\int_{-1}^1 P_n = 0$. $\int_{-1}^1 P_n x^m = 0$ $m < n$

Leibniz Rule: ex-ple $\frac{d^q}{dx^q} (x \sin x) = x \frac{d^q}{dx^q} \sin x + \frac{d^q}{dx^q} x \sin x$

$\frac{d^n}{dx^n} fg = f \frac{d^n}{dx^n} g + n \frac{d^{n-1}}{dx^{n-1}} f \frac{d}{dx} g + \dots + \frac{n!}{2!} \frac{d^2}{dx^2} f \frac{d}{dx} g + \dots$

$(a+b)^n = a^n + n a^{n-1} b + \frac{n(n-1)}{2!} a^{n-2} b^2 + \dots + b^n$ to prove $B(p, q) = \int_0^1 \frac{x^{p-1} (1-x)^{q-1}}{(1+y)^{p+q}}$ sub $x = \frac{y}{1+y}$

binomial coeff $\binom{n}{r} = \frac{n!}{(n-r)! r!}$

$(a+b)^n = a^n \binom{n}{0} b^0 + a^{n-1} \binom{n}{1} b^1 + a^{n-2} \binom{n}{2} b^2 + \dots + \binom{n}{n} a^0 b^n$

HW: single card drawn from deck. what is prob. if it is either ace or red or both?
 $P = P(\text{Ace}) + P(\text{Red}) - P(\text{Ace and Red}) = \frac{4}{52} + \frac{13}{52} - \frac{4}{52} = \frac{13}{13} = 1$

what is prob that a number is $1 \leq n \leq 11$ is divisible by both 6 and 10?
 by either 6 or 10? both? A = not divisible by 6 $\Rightarrow P(A) = \frac{16}{99}$
 B = not divisible by 10 $\Rightarrow P(B) = \frac{9}{99}$
 $P(A \cap B) = P(A)P(B) = \frac{16}{99} \cdot \frac{9}{99} = \frac{16}{1089}$
 $P(A \cup B) = P(A) + P(B) - P(A \cap B) = \frac{16}{99} + \frac{9}{99} - \frac{16}{1089} = \frac{2}{9}$

HW: player makes ball in 3 baskets out of 4. How many tries need to have chance .99 of at least one basket? prob. not scoring after n tries = $(1-p)^n = (\frac{1}{4})^n$
 solve $(\frac{1}{4})^n = 0.01$. $n \log \frac{1}{4} = \log(0.01) \Rightarrow n = 4$

HW: separate wave eq. in 2D rect. $z = (x, y, z)$.
 $\frac{\partial^2 z}{\partial x^2} + \frac{\partial^2 z}{\partial y^2} = \frac{1}{v^2} \frac{\partial^2 z}{\partial t^2} \Rightarrow z = X Y T$
 $\Rightarrow Y T X'' + X T Y'' = \frac{1}{v^2} X Y T''$
 $\Rightarrow \frac{X''}{X} + \frac{Y''}{Y} = \frac{1}{v^2 T} \Rightarrow$ each is a function of one variable, and not in others.
 $\Rightarrow \frac{X''}{X} = -k_x^2, \frac{Y''}{Y} = -k_y^2, \frac{T''}{T} = -(k_x^2 + k_y^2) v^2 = -\omega^2$
 $\Rightarrow X = \begin{cases} \sin k_x x \\ \cos k_x x \end{cases}, Y = \begin{cases} \sin k_y y \\ \cos k_y y \end{cases}, T = \begin{cases} \sin(\omega t) \\ \cos(\omega t) \end{cases}$

$\int_0^\infty x^n e^{-ax} = \frac{n!}{a^{n+1}}$
 $\int_0^\infty e^{-x} x^n = n!$
 $\Gamma(n) = \int_0^\infty x^{n-1} e^{-x} = (n-1)!$
 $\Gamma(n+1) = n!$
 $\Gamma(\frac{1}{2}) = \sqrt{\pi}$
 $\text{Erf}(x) = \frac{2}{\sqrt{\pi}} \int_0^x e^{-t^2} dt$

HW: Separat Schrodinger eq. $\nabla^2 \psi + (\epsilon - V) \psi = 0$ in spherical.
 write in spherical = $\frac{1}{2} \frac{\partial}{\partial r} (r^2 \frac{\partial \psi}{\partial r}) + \frac{1}{r^2} \sin^2 \theta \frac{\partial}{\partial \theta} (\sin^2 \theta \frac{\partial \psi}{\partial \theta}) + \frac{1}{r^2 \sin^2 \theta} \frac{\partial^2 \psi}{\partial \phi^2} + (\epsilon - V(r)) \psi = 0$
 $\psi = R(r) \Theta(\theta) \Phi(\phi)$ Sub in above and multiply by $\frac{r^2}{R \Theta \Phi}$
 $\frac{1}{R} \frac{d}{dr} (r^2 \frac{dR}{dr}) + (\epsilon - V(r)) \frac{r^2}{R} + \frac{1}{\Theta} \frac{1}{\sin^2 \theta} \frac{d}{d\theta} (\sin^2 \theta \frac{d\Theta}{d\theta}) + \frac{1}{\Phi} \frac{1}{\sin^2 \theta} \frac{d^2 \Phi}{d\phi^2} = 0$

$\nabla^2 u = 0$ Solution: $u(x, y, z) = \begin{cases} e^{kx} \cos ky \\ e^{ky} \sin kx \\ e^{-ky} \cos kx \\ e^{-ky} \sin kx \end{cases}$

$\Rightarrow K + \frac{1}{\Theta} \frac{1}{\sin^2 \theta} \frac{d}{d\theta} (\sin^2 \theta \frac{d\Theta}{d\theta}) + \frac{1}{\Phi} \frac{1}{\sin^2 \theta} \frac{d^2 \Phi}{d\phi^2} = 0$ multiply by $\sin^2 \theta$ and let $\frac{1}{\Phi} \frac{d^2 \Phi}{d\phi^2} = -m^2$. $\Rightarrow \Phi = \sum C_m \sin m\phi$. so we now have
 $K + \frac{1}{\Theta} \frac{1}{\sin^2 \theta} \frac{d}{d\theta} (\sin^2 \theta \frac{d\Theta}{d\theta}) - \frac{m^2}{\sin^2 \theta} = 0$ multiply by Θ
 $\frac{1}{\sin^2 \theta} \frac{d}{d\theta} (\sin^2 \theta \frac{d\Theta}{d\theta}) - \frac{m^2}{\sin^2 \theta} \Theta + K \Theta = 0$ solution $\Theta = P_l^m(\cos \theta)$
 so $\psi = P_l^m(\cos \theta) \begin{cases} \sin m\phi \\ \cos m\phi \end{cases}$ HW: show that gradient desc so $V = -\frac{Gm}{\sqrt{x^2 + y^2 + z^2}}$ find $\frac{\partial V}{\partial x}, \frac{\partial V}{\partial y}$ and add $\frac{\partial^2 V}{\partial x^2}, \frac{\partial^2 V}{\partial y^2}, \frac{\partial^2 V}{\partial z^2} = 0$

$\nabla^2 = f$ $u(x, y, z) = -\frac{1}{4\pi} \iiint \frac{f(x', y', z')}{r} dx' dy' dz'$
 $\nabla^2 u = \frac{1}{\alpha^2} \frac{\partial^2 u}{\partial t^2}$ $u(t, x) = \begin{cases} e^{-k^2 \alpha^2 t} \cos kx \\ e^{k^2 \alpha^2 t} \sin kx \end{cases}$
 For bar (one dimension)

Since attached to supports. $X=0$ at $x=0$ and $x=d$
 $Y=0$ at $y=0, y=b$
 $\Rightarrow X = \sin k_x x$, and at $x=d \Rightarrow \sin k_x d = 0$
 $\Rightarrow k_x = \frac{n\pi}{d} \Rightarrow X = \sin \frac{n\pi x}{d}$, similarly
 $Y = \sin \frac{m\pi y}{b} \Rightarrow T = \begin{cases} \sin(\omega t) \\ \cos(\omega t) \end{cases}$

$\nabla^2 = \frac{1}{r^2} \frac{\partial}{\partial r} (r^2 \frac{\partial u}{\partial r})$
 $Y = X T, X = \begin{cases} \cos k_x x \\ \sin k_x x \end{cases}, T = \begin{cases} \cos \omega t \\ \sin \omega t \end{cases}$
 $Y = \begin{cases} \cos k_y y \\ \sin k_y y \end{cases}$
 $X = \begin{cases} \cos k_x x \\ \sin k_x x \end{cases}, Y = \begin{cases} \cos k_y y \\ \sin k_y y \end{cases}$
 $Z = X Y T$ for 2D wave.
 $X = \begin{cases} \cos k_x x \\ \sin k_x x \end{cases}, Y = \begin{cases} \cos k_y y \\ \sin k_y y \end{cases}$

HW: Find solution for steady state temp distribution in solid semi-infinite cylinder if $u=0$ at $r=1, u=y \cos \theta$ at $z=0$.
 $u = \begin{cases} J_n(kr) \sin(n\theta) e^{-kz} \\ J_n(kr) \cos(n\theta) e^{-kz} \end{cases}$ since $u=r \sin \theta$ when $z=0$, $k=y$ and set $n=1$
 $\Rightarrow u = J_1(kr) \sin(\theta) e^{-kz} \Rightarrow u = \sum_{m=1}^{\infty} C_m J_1(k_m r) \sin \theta e^{-k_m z}$
 $z=0$. B.C. to find C_m . $u = r \sin \theta = \sum C_m J_1(k_m r) \sin \theta$.
 take inner product wrt. $r J_1(k_m r)$ from $r=0$ to 1 .
 $\int_0^1 r \sin \theta r J_1(k_m r) dr = \sum C_m \int_0^1 J_1(k_m r) \sin \theta r J_1(k_n r) dr$
 $\Rightarrow \int_0^1 r^2 J_1(k_m r) = \sum C_m \int_0^1 J_1(k_m r) r J_1(k_n r) dr$
 From orthogonality of Bessel: $\int_0^1 J_p(k_m r) r J_p(k_n r) dr = 0$ $n \neq m$.
 $\Rightarrow \int_0^1 r^2 J_1(k_m r) dr = C_m \int_0^1 r J_1(k_m r) J_1(k_m r) dr$
 $C_m = \frac{\int_0^1 r^2 J_1(k_m r) dr}{\int_0^1 r J_1(k_m r) J_1(k_m r) dr} = \frac{\int_0^1 r^2 J_1(k_m r) dr}{\frac{1}{2} [J_2(k_m)]^2} = \frac{1}{J_2(k_m)}$
 $\Rightarrow C_m = \frac{1}{J_2(k_m)} = \frac{2}{k_m J_2(k_m)} \Rightarrow u = \sum C_m J_1(k_m r) \sin \theta e^{-k_m z} = \sum \frac{2}{k_m J_2(k_m)} J_1(k_m r) \sin \theta e^{-k_m z}$

Laplace eq. in cylind coords:
 $\nabla^2 u = \frac{1}{r} \frac{\partial}{\partial r} (r^2 \frac{\partial u}{\partial r}) + \frac{1}{r^2} \frac{\partial^2 u}{\partial \theta^2} + \frac{\partial^2 u}{\partial z^2} = 0$
 $u = R(r) \Theta(\theta) Z(z), Z = \begin{cases} e^{kz} \\ e^{-kz} \end{cases}, \Theta = \begin{cases} \sin \theta \\ \cos \theta \end{cases}, R(r) = J_n(kr)$
 $\Rightarrow u = \begin{cases} J_n(kr) \sin n\theta e^{-kz} \\ J_n(kr) \cos n\theta e^{kz} \end{cases} \Rightarrow u = J_0(k_m r) e^{-k_m z}$
 $\leftarrow k$ is zero of J_n .

Expansions of $f(x)$:
 $f(x) = a_0 P_0 + a_1 P_1 + a_2 P_2$
 $a_i = \frac{\int_{-1}^1 f(x) P_i(x) dx}{\int_{-1}^1 P_i(x) P_i(x) dx} = \frac{2}{2^i i!}$
 $\Rightarrow u = r^2 P_2^0(\cos \theta) = r^2 \frac{3}{2} \cos^2 \theta - \frac{r^2}{2}$

Laplace spherical: $\nabla^2 u = \frac{1}{r^2} \frac{\partial}{\partial r} (r^2 \frac{\partial u}{\partial r}) + \frac{1}{r^2 \sin^2 \theta} \frac{\partial^2 u}{\partial \theta^2} + \frac{1}{r^2 \sin^2 \theta} \frac{\partial^2 u}{\partial \phi^2} = 0$
 $u = R(r) \Theta(\theta) \Phi(\phi), \Phi = \begin{cases} \cos m\phi \\ \sin m\phi \end{cases}, \Theta = \begin{cases} P_l^m(\cos \theta) \\ P_l^m(\sin \theta) \end{cases}, R(r) = \begin{cases} r^l \\ r^{-l-1} \end{cases}$
 $u = r^l P_l^m(\cos \theta) \begin{cases} \sin m\phi \\ \cos m\phi \end{cases}$. For symm. $m=0 \Rightarrow u = r^l P_l^0(\cos \theta)$

HW: Find steady state temp dist. inside sphere $r=1$ when surface temp is $u = \cos \theta - (\cos \theta)^3$. $u = r^l P_l^m(\cos \theta)$ $\begin{cases} \sin m\theta \\ \cos m\theta \end{cases} \Rightarrow$ set $m=0$
 $u = r^l P_l^0(\cos \theta) \Rightarrow u_0 = \sum C_l r^l P_l^0(\cos \theta)$. when $r=1, u = \cos \theta - (\cos \theta)^3$
 $\Rightarrow \cos \theta - (\cos \theta)^3 = \sum C_l P_l^0(\cos \theta)$. let $x = \cos \theta$. we see that
 $x^3 - x^3 = \frac{2}{5} P_1(x) - \frac{2}{5} P_3(x) \Rightarrow C_1 = \frac{2}{5}, C_3 = -\frac{2}{5} \Rightarrow u = \frac{2}{5} r^1 P_1^0(\cos \theta) - \frac{2}{5} r^3 P_3^0(\cos \theta)$

Fuchs Theorem: write ODE as $y'' + f(x)y' + g(x)y = 0$. if $x \leq a$ and $x \geq b$ are expandable in convergent power series $\sum a_n x^n$, we say ODE is regular at origin. if one solution found, second $y_2 = y_1 \ln x + \dots$ example: $4x^2 y'' + y = 0$ has one solution $y_1 = \sqrt{x}$. so second is $y_2 = \sqrt{x} \ln x + \dots$ sub into DE
 $y' = \frac{1}{2} \frac{1}{\sqrt{x}} \ln x + \frac{1}{2} + \sum b_n(n+1)x^{n+1/2}$
 sub into ODE, set $n=0 \Rightarrow$ invid $a_0 = 0 = \frac{1}{2}$.

Bessel: $x^2 y'' + x y' + (x^2 - p^2) y = 0, y_1 = J_p(x) = \sum \frac{(-1)^n}{\Gamma(n+1)\Gamma(n+1)} (\frac{x}{2})^{2n+p}$
 $y_2 = Y_p = \frac{\cos(p\pi) J_p(x) - J_{-p}(x)}{\sin p\pi}$
 orthogonality: $\int_a^b x J_p(ax) J_p(bx) dx = \begin{cases} 0 & a \neq b \\ \frac{1}{2} J_{p+1}^2(a) = \frac{1}{2} J_{p-1}^2(a) & a=b \end{cases}$
 recursive: $\frac{d}{dx} (x^p J_p) = x^p J_{p-1}, J_{p-1} - J_{p+1} = 2J_p, \frac{d}{dx} (\frac{1}{x^p} J_p) = -\frac{1}{x^p} J_{p+1}$
 $J_p' = -\frac{p}{x} J_p + J_{p-1} = \frac{p}{x} J_p - J_{p+1}, j_n = \sqrt{\frac{\pi}{2xc}} J_{n+1/2}(x) = x^n (-\frac{1}{x} \frac{d}{dx})^n (\frac{\sin x}{x})$

Legendre $(1-x^2) y'' - 2xy' + l(l+1)y = 0, P_0=1, P_1=x, P_2 = \frac{1}{2}(3x^2-1), P_3(x) = \frac{1}{2}(5x^3-3x)$ normalization. $\int_{-1}^1 (P_l(x))^2 = \frac{2}{2l+1}$ $\frac{P_l}{r} = \frac{n!}{(n-r)!}$ order n
 $y_1 = P_2(x)$. orthogonality: $\int_{-1}^1 P_2(x) P_m(x) dx = 0$ $m \neq 2$ also $\int_{-1}^1 P_2(x) x dx = 0$

Leibniz Rule: Example: $\frac{d^9}{dx^9} (x \sin x) = x \frac{d^9}{dx^9} \sin x + 9 \frac{d^8}{dx^8} x \frac{d}{dx} \sin x + \frac{9 \cdot 8}{2} \frac{d^7}{dx^7} x^2 \frac{d^2}{dx^2} \sin x + \dots$
 $\int_0^L \sin^2 \frac{n\pi x}{L} dx = \frac{L}{2}$ HW: box A has 5 red balls, 6 black, box B has 5 red balls, 8 white. $P(\text{pick A}) \times P(\text{pick red from A}) + P(\text{pick B}) \times P(\text{pick red from B})$
 what is prob of picking red ball? $\frac{5}{11} \cdot \frac{5}{11} + \frac{6}{11} \cdot \frac{5}{11} = \frac{55}{121}$

Leibniz Rule: Example: $\frac{d^9}{dx^9} (x \sin x) = x \frac{d^9}{dx^9} \sin x + 9 \frac{d^8}{dx^8} x \frac{d}{dx} \sin x + \frac{9 \cdot 8}{2} \frac{d^7}{dx^7} x^2 \frac{d^2}{dx^2} \sin x + \dots$
 $\int_0^L \sin^2 \frac{n\pi x}{L} dx = \frac{L}{2}$ HW: box A has 5 red balls, 6 black, box B has 5 red balls, 8 white. $P(\text{pick A}) \times P(\text{pick red from A}) + P(\text{pick B}) \times P(\text{pick red from B})$
 what is prob of picking red ball? $\frac{5}{11} \cdot \frac{5}{11} + \frac{6}{11} \cdot \frac{5}{11} = \frac{55}{121}$

Leibniz Rule: Example: $\frac{d^9}{dx^9} (x \sin x) = x \frac{d^9}{dx^9} \sin x + 9 \frac{d^8}{dx^8} x \frac{d}{dx} \sin x + \frac{9 \cdot 8}{2} \frac{d^7}{dx^7} x^2 \frac{d^2}{dx^2} \sin x + \dots$
 $\int_0^L \sin^2 \frac{n\pi x}{L} dx = \frac{L}{2}$ HW: box A has 5 red balls, 6 black, box B has 5 red balls, 8 white. $P(\text{pick A}) \times P(\text{pick red from A}) + P(\text{pick B}) \times P(\text{pick red from B})$
 what is prob of picking red ball? $\frac{5}{11} \cdot \frac{5}{11} + \frac{6}{11} \cdot \frac{5}{11} = \frac{55}{121}$

Stirling approx $n! \approx n^n e^{-n} \sqrt{2\pi n}$

$\frac{\partial^2 z}{\partial x^2} + \frac{\partial^2 z}{\partial y^2} = \frac{1}{v^2} \frac{\partial^2 z}{\partial t^2} \Rightarrow z = X Y T$
 $\Rightarrow Y T X'' + X T Y'' = \frac{1}{v^2} X Y T''$
 $\Rightarrow \frac{X''}{X} + \frac{Y''}{Y} = \frac{1}{v^2 T} \Rightarrow$ each is a function of one variable, and not in others.
 $\Rightarrow \frac{X''}{X} = -k_x^2, \frac{Y''}{Y} = -k_y^2, \frac{T''}{T} = -(k_x^2 + k_y^2) v^2 = -\omega^2$
 $\Rightarrow X = \begin{cases} \sin k_x x \\ \cos k_x x \end{cases}, Y = \begin{cases} \sin k_y y \\ \cos k_y y \end{cases}, T = \begin{cases} \sin(\omega t) \\ \cos(\omega t) \end{cases}$

Since attached to supports. $X=0$ at $x=0$ and $x=d$
 $Y=0$ at $y=0, y=b$
 $\Rightarrow X = \sin k_x x$, and at $x=d \Rightarrow \sin k_x d = 0$
 $\Rightarrow k_x = \frac{n\pi}{d} \Rightarrow X = \sin \frac{n\pi x}{d}$, similarly
 $Y = \sin \frac{m\pi y}{b} \Rightarrow T = \begin{cases} \sin(\omega t) \\ \cos(\omega t) \end{cases}$

HW: Find solution for steady state temp distribution in solid semi-infinite cylinder if $u=0$ at $r=1, u=y \cos \theta$ at $z=0$.
 $u = \begin{cases} J_n(kr) \sin(n\theta) e^{-kz} \\ J_n(kr) \cos(n\theta) e^{-kz} \end{cases}$ since $u=r \sin \theta$ when $z=0$, $k=y$ and set $n=1$
 $\Rightarrow u = J_1(kr) \sin(\theta) e^{-kz} \Rightarrow u = \sum_{m=1}^{\infty} C_m J_1(k_m r) \sin \theta e^{-k_m z}$
 $z=0$. B.C. to find C_m . $u = r \sin \theta = \sum C_m J_1(k_m r) \sin \theta$.
 take inner product wrt. $r J_1(k_m r)$ from $r=0$ to 1 .
 $\int_0^1 r \sin \theta r J_1(k_m r) dr = \sum C_m \int_0^1 J_1(k_m r) \sin \theta r J_1(k_n r) dr$
 $\Rightarrow \int_0^1 r^2 J_1(k_m r) = \sum C_m \int_0^1 J_1(k_m r) r J_1(k_n r) dr$
 From orthogonality of Bessel: $\int_0^1 J_p(k_m r) r J_p(k_n r) dr = 0$ $n \neq m$.
 $\Rightarrow \int_0^1 r^2 J_1(k_m r) dr = C_m \int_0^1 r J_1(k_m r) J_1(k_m r) dr$
 $C_m = \frac{\int_0^1 r^2 J_1(k_m r) dr}{\int_0^1 r J_1(k_m r) J_1(k_m r) dr} = \frac{\int_0^1 r^2 J_1(k_m r) dr}{\frac{1}{2} [J_2(k_m)]^2} = \frac{1}{J_2(k_m)}$
 $\Rightarrow C_m = \frac{1}{J_2(k_m)} = \frac{2}{k_m J_2(k_m)} \Rightarrow u = \sum C_m J_1(k_m r) \sin \theta e^{-k_m z} = \sum \frac{2}{k_m J_2(k_m)} J_1(k_m r) \sin \theta e^{-k_m z}$

Bessel: $x^2 y'' + x y' + (x^2 - p^2) y = 0, y_1 = J_p(x) = \sum \frac{(-1)^n}{\Gamma(n+1)\Gamma(n+1)} (\frac{x}{2})^{2n+p}$
 $y_2 = Y_p = \frac{\cos(p\pi) J_p(x) - J_{-p}(x)}{\sin p\pi}$
 orthogonality: $\int_a^b x J_p(ax) J_p(bx) dx = \begin{cases} 0 & a \neq b \\ \frac{1}{2} J_{p+1}^2(a) = \frac{1}{2} J_{p-1}^2(a) & a=b \end{cases}$
 recursive: $\frac{d}{dx} (x^p J_p) = x^p J_{p-1}, J_{p-1} - J_{p+1} = 2J_p, \frac{d}{dx} (\frac{1}{x^p} J_p) = -\frac{1}{x^p} J_{p+1}$
 $J_p' = -\frac{p}{x} J_p + J_{p-1} = \frac{p}{x} J_p - J_{p+1}, j_n = \sqrt{\frac{\pi}{2xc}} J_{n+1/2}(x) = x^n (-\frac{1}{x} \frac{d}{dx})^n (\frac{\sin x}{x})$

Legendre $(1-x^2) y'' - 2xy' + l(l+1)y = 0, P_0=1, P_1=x, P_2 = \frac{1}{2}(3x^2-1), P_3(x) = \frac{1}{2}(5x^3-3x)$ normalization. $\int_{-1}^1 (P_l(x))^2 = \frac{2}{2l+1}$ $\frac{P_l}{r} = \frac{n!}{(n-r)!}$ order n
 $y_1 = P_2(x)$. orthogonality: $\int_{-1}^1 P_2(x) P_m(x) dx = 0$ $m \neq 2$ also $\int_{-1}^1 P_2(x) x dx = 0$

Leibniz Rule: Example: $\frac{d^9}{dx^9} (x \sin x) = x \frac{d^9}{dx^9} \sin x + 9 \frac{d^8}{dx^8} x \frac{d}{dx} \sin x + \frac{9 \cdot 8}{2} \frac{d^7}{dx^7} x^2 \frac{d^2}{dx^2} \sin x + \dots$
 $\int_0^L \sin^2 \frac{n\pi x}{L} dx = \frac{L}{2}$ HW: box A has 5 red balls, 6 black, box B has 5 red balls, 8 white. $P(\text{pick A}) \times P(\text{pick red from A}) + P(\text{pick B}) \times P(\text{pick red from B})$
 what is prob of picking red ball? $\frac{5}{11} \cdot \frac{5}{11} + \frac{6}{11} \cdot \frac{5}{11} = \frac{55}{121}$

Leibniz Rule: Example: $\frac{d^9}{dx^9} (x \sin x) = x \frac{d^9}{dx^9} \sin x + 9 \frac{d^8}{dx^8} x \frac{d}{dx} \sin x + \frac{9 \cdot 8}{2} \frac{d^7}{dx^7} x^2 \frac{d^2}{dx^2} \sin x + \dots$
 $\int_0^L \sin^2 \frac{n\pi x}{L} dx = \frac{L}{2}$ HW: box A has 5 red balls, 6 black, box B has 5 red balls, 8 white. $P(\text{pick A}) \times P(\text{pick red from A}) + P(\text{pick B}) \times P(\text{pick red from B})$
 what is prob of picking red ball? $\frac{5}{11} \cdot \frac{5}{11} + \frac{6}{11} \cdot \frac{5}{11} = \frac{55}{121}$

It is known that 1% of population have cancer. It is also known that a test of this cancer is positive in 99% of people who have it but is also positive in 2% of people who don't have it. What is prob. that a person who test positive has cancer of this type? Let A = event person has cancer, B = Event test is positive. Find $P_B(A) = \frac{P(A \cap B)}{P(B)} = \frac{P(A) P_B(A)}{P(A) P_B(A) + P(\bar{A}) P_B(\bar{A})}$. Given as $P(A) = 0.01$, $P(B|A) = 0.99$, $P(B|\bar{A}) = 0.02$. Then $P_B(A) = \frac{0.01 \times 0.99}{0.01 \times 0.99 + 0.02 \times 0.99} = 0.0297$. $P_B(A) = 0.99$ given. then $P_B(B) = 0.01 \times 0.99 + 0.02 \times 0.99 = 0.0297$ so 3% chance person who test positive has cancer.

5 cards are dealt from Deck. what is P(they are all same suite)? $P = \frac{\# \text{ ways to select suite} \times \# \text{ way to select 5 cards out of one suite}}{\# \text{ ways to select 5 cards from 52}} = \frac{4 \times \binom{13}{5}}{\binom{52}{5}} = 1.98 \times 10^{-5}$. what is Prob they are all diamonds? $\frac{\binom{13}{5}}{\binom{52}{5}} = 4.95 \times 10^{-6}$. what is prob they are all face card? $\frac{\binom{12}{5}}{\binom{52}{5}}$

What is prob they are from same suite and in series? $4 \times \frac{\binom{13}{5}}{\binom{52}{5}} = 1.98 \times 10^{-5}$. In family of 5 children, what is Prob. there are 2 boys and 2 girls? $\frac{\binom{5}{2}}{2^5} = \frac{5}{16}$. what is prob. that 2 and 3 of clubs are next to each others in Deck of card? $\frac{2 \times 2 \times 2 \times 2 \times 2}{52 \times 51 \times 50 \times 49 \times 48} = \frac{1}{26}$

2 cards drawn from deck. what is prob. they are both ace? $\frac{\binom{4}{2}}{\binom{52}{2}} = \frac{1}{271}$ or $\frac{4}{52} \times \frac{3}{51}$; if you know one is Ace, what is prob. both are ace? $P = \frac{\binom{3}{1}}{\binom{49}{1}} = \frac{3}{49}$. if one is ace of spade, what is prob both are ace? $\frac{3}{48+3} = \frac{1}{17}$

Maxwell-Boltzmann: Balls are different. Can have more than one ball in Box. Fermi-Dirac: Balls are same, each Box can have one Ball only inst at most. Bose-Einstein: Balls are same, can have more than one ball in same Box. MB: $\sum b_i = \# \text{ boxes}$, FD: number of ways to put b balls in n boxes = $\binom{n}{b}$. BE: $\binom{n+b-1}{b}$. $\sin 2x = 2 \sin x \cos x$, $\cos 2x = 2 \cos^2 x - 1$, $\int e^{ax} dx = \frac{1}{a} e^{ax} + C$, $\int e^{ax} \ln x dx = \frac{1}{a} \ln x e^{ax} - \frac{1}{a^2} e^{ax} + C$

A weighted coin with p prob. for head is tossed 3 times, x = number of heads minus tail. find μ, σ . $x_i = 3, 2, 1, 0, -1, -2, -3$. $P_i = p^3, p^2(1-p), p(1-p)^2, (1-p)^3$. $\mu = \sum x_i P_i = 3p^3 + 3p^2(1-p) - 3p(1-p)^2 - 3(1-p)^3 = 3(2p-1)$. $\text{Var} = \sum x_i^2 P_i - \mu^2 = 12p(1-p)$. For binomial distribution $\bar{x} = np, \sigma = \sqrt{npq}$, $\text{Var} = npq$. Var can also be written $x^2 - \bar{x}^2$.

Trick $\lim_{N \rightarrow \infty} \left(\frac{1-p}{N}\right)^N = \frac{1}{e}$. to proof: $\left(\frac{1-p}{N}\right)^N = e^{N \log(1-p/N)} = e^{-N \frac{p}{N} - \dots} = e^{-p}$. Recursive Hermite: $H_{n+1}(x) = 2x H_n - 2n H_{n-1}$. Gaussian probability density for a random variable with μ, σ is $P = \frac{1}{\sigma \sqrt{2\pi}} e^{-\frac{(x-\mu)^2}{2\sigma^2}}$, Cumulative = $\frac{1}{\sigma \sqrt{2\pi}} \int_{-\infty}^x e^{-\frac{(t-\mu)^2}{2\sigma^2}} dt$. Example: Find p of exactly 52 heads in 100 toss: $\mu = np = 100 \times \frac{1}{2} = 50$. $\sigma = \sqrt{npq} = \sqrt{100 \times \frac{1}{2} \times \frac{1}{2}} = 5 \Rightarrow t = \frac{x-\mu}{\sigma} = \frac{52-50}{5} = 0.4$. Then $P(x) = \frac{1}{\sigma} \phi(t) = \frac{1}{5} \phi(0.4)$. but $\phi(t) = \frac{1}{\sqrt{2\pi}} e^{-t^2/2} \Rightarrow \phi(0.4) = 0.36 \Rightarrow P = 0.07$

HW: Normal approx (Gaussian) to binomial. Find prop. of getting exactly 120 aces in 720 tosses of die: $\sigma = \sqrt{npq} = \sqrt{720 \times \frac{1}{6} \times \frac{5}{6}} = 10$. $\mu = np = 720 \times \frac{1}{6} = 120 \Rightarrow P = \frac{1}{\sigma \sqrt{2\pi}} e^{-\frac{t^2}{2}}$ where $t = \frac{x-\mu}{\sigma} \Rightarrow P = 0.0398$

HW: Using Gaussian distribution, Find prob of getting between 499,000 and 501,000 heads in 10^6 tosses: $\mu = np = 10^6 \times \frac{1}{2} = 500,000$. $\sigma = \sqrt{npq} = 10^6 \times \frac{1}{2} \times \frac{1}{2} = 500 \Rightarrow t_1 = \frac{499,000 - 500,000}{500} = -2, t_2 = \frac{501,000 - 500,000}{500} = 2$. So want $P(-2, 2) = P(-2, 0) + P(0, 2) = 2P(0, 2)$. need table to find: $= 2 \times \frac{1}{2} \text{erf}\left(\frac{2}{\sqrt{2}}\right) = \text{erf}\left(\frac{2}{\sqrt{2}}\right) = 0.954$

Summary Gaussian: Find t_1, t_2 . Then μ, σ . Then write $P(x_1, x_2) = P(-x_1, -x_2) + P(x_1, x_2) = 2P(x_1, x_2) = 2 \times \frac{1}{2} \text{erf}\left(\frac{x_2}{\sigma}\right)$ (to find prob. between t_1, t_2)

Sample space for 2 die sum: $x = 2, 3, 4, 5, 6, 7, 8, 9, 10, 11, 12$. $P_i = 1, 2, 3, 4, 5, 6, 5, 4, 3, 2, 1 \Rightarrow 36$. $\mu = 7, \text{Var} = \frac{35}{6}$

HW: Coin is tossed repeatedly. x = number of toss in which head first appear. Find P_i, \bar{x}, Var . $x_i = 1, 2, 3, \dots \Rightarrow \mu = \sum_{n=1}^{\infty} n \left(\frac{1}{2}\right)^n = 2$. $\text{Var} = \sum_{n=1}^{\infty} n^2 \left(\frac{1}{2}\right)^n - \mu^2 = 6 - 4 = 2$

HW: Poisson. In an alpha particle counting, number of alpha particles is recorded each minute for 50 hrs. total particles is 6000. in how many 1 minute intervals you expect no particles? Exactly 1? here $\mu = \frac{6000}{50 \times 60} = 2$ particles per min $\Rightarrow P = \frac{\mu^n}{n!} e^{-\mu}$. For $n=0 \Rightarrow P = e^{-2} = 0.135$, so 13% of time. i.e. 406 1-minute intervals.

HW: Poisson. Suppose you have 5 exams during 5 days. Find prob on a given day you have no exams, one exam? $P = e^{-\mu} e^{-\mu} = e^{-2}$. $\mu = 1$ exam per day. $\Rightarrow P = e^{-1}$ etc.

HW: if there are 100 misprints in a 40 pages. on how many pages you expect to find no misprints? 2 misprint? $\mu = \frac{100}{40} = 2.5$. so Prob. of no misprint on given page = $P_0 = \frac{\mu^0}{0!} e^{-\mu} = 0.082$. \Rightarrow expected pages with no misprints = $40 \times P_0 = 3.3$. \Rightarrow " " " 2 misprints = $40 P_2 = 40 \times \frac{2.5^2}{2!} e^{-2.5} = 10.3$ etc.

HW: Coin is tossed repeatedly. x = number of toss in which head first appear. Find P_i, \bar{x}, Var . $x_i = 1, 2, 3, \dots \Rightarrow \mu = \sum_{n=1}^{\infty} n \left(\frac{1}{2}\right)^n = 2$. $\text{Var} = \sum_{n=1}^{\infty} n^2 \left(\frac{1}{2}\right)^n - \mu^2 = 6 - 4 = 2$

HW: Binomial probability density: $f(x) = \binom{n}{x} p^x q^{n-x}$. This is prob. of exactly x success out of n trials. P = Prob. of success. Prob. density functions answer questions: what is prob. x is ... distribution (or cumulative) answers: what is prob. of at most x.

Chapter 3

Exams

Local contents

3.1	First exam	12
3.2	Second exam	13
3.3	Final exam	14

3.1 First exam

3.1.1 Questions

Math 121B midterm, Thursday 2004 Feb 19, 9:30-11:00am.

Please make sure that your name is on everything you hand in.
 You are allowed calculators and 1 page of notes.
 All questions have about the same number of marks.

- Express the integral

$$\int_0^{\infty} \frac{y^2 dy}{(1+y)^6}$$
 as a beta function, hence in terms of gamma functions, and use this to evaluate it explicitly. (Hint: put $x = y/(1+y)$ in the definition $B(p, q) = \int_0^1 x^{p-1}(1-x)^{q-1} dx = \Gamma(p)\Gamma(q)/\Gamma(p+q)$.)
- Use Stirling's formula $n! \cong n^n e^{-n} \sqrt{2\pi n}$ to evaluate

$$\lim_{n \rightarrow \infty} \frac{(2n)! \sqrt{n}}{2^{2n} (n!)^2}.$$
- Find the general solution of

$$(x^2 + 1)y'' - 2xy' + 2y = 0$$
 by writing y as a power series $a_0 + a_1x + a_2x^2 + a_3x^3 + \dots$ in x .
- Find the best (in the least squares sense) second-degree polynomial approximation $a_0 + a_1x + a_2x^2$ to the function x^4 for $-1 \leq x \leq 1$. (The first few Legendre polynomials are $P_0(x) = 1$, $P_1(x) = x$, $P_2(x) = (3x^2 - 1)/2$, $P_3(x) = (5x^3 - 3x)/2$, $P_4(x) = (35x^4 - 30x^2 + 3)/8$.)
- Find $P_6(0)$ from Rodrigues' formula

$$P_l(x) = \frac{1}{2^l l!} \frac{d^l}{dx^l} (x^2 - 1)^l.$$

Figure 3.1: Questions

3.2 Second exam

3.2.1 Questions

Math 121B midterm, 2004 April 1.

Please make sure that your name is on everything you hand in.
You are allowed calculators and 1 page of notes.
All questions have about the same number of marks.

- Solve the following differential equation by the method of Frobenius (generalized power series):

$$x^2 y'' - 6y = 0.$$
- Express $\frac{d}{dx} J_0(x)$ in terms of $J_1(x)$, using the definition

$$J_p(x) = \sum_{n=0}^{\infty} \frac{(-1)^n (x/2)^{2n+p}}{n!(n+p)!}.$$
- Use the relation

$$\exp(2xh - h^2) = \sum_{n=0}^{\infty} \frac{H_n(x)h^n}{n!}$$
 to calculate the Hermite polynomials H_0, H_1, H_2 , and H_3 . What is the coefficient of x^n of $H_n(x)$?
- The Laguerre differential equation is

$$xy'' + (1-x)y' + py = 0.$$
 Find the polynomial solution $L_p(x)$ with constant term 1 for $p = 3$.
- A bar of length π with insulated sides is initially at a temperature of 1. Starting at time $t = 0$, the ends are held at a temperature of 0. Find the temperature distribution $T(x, t)$ in the bar at time t . The temperature T satisfies the heat equation

$$\frac{\partial T}{\partial t} = \frac{\partial^2 T}{\partial x^2}.$$

1

Figure 3.2: Questions

3.3 Final exam

3.3.1 Questions

Math 121B Final 2004 May 18 8:00-11:00am .

Please make sure that your name is on everything you hand in.
 You are allowed calculators and 1 sheet of notes.
 All questions have about the same number of marks.

✓ 1. Evaluate $\int_0^{\infty} x^{10} e^{-x^2} dx.$
 (Hint: put $y = x^2.$)

✓ 2. If $|x| = \sum_l c_l P_l(x)$ for $|x| \leq 1$ is the expansion of $|x|$ as a Legendre series, then find the coefficients c_l for $l = 0, 1, 2.$

0 3. Evaluate $\lim_{n \rightarrow \infty} \frac{\Gamma(n + 1/2)}{\sqrt{n}\Gamma(n)}.$

1 ? 4. By repeated integration by parts, find the first 3 terms of the asymptotic series for $\int_x^{\infty} t^{n-1} e^{-t} dt.$

✓ 5. Find a nonzero solution of the following differential equation:
 $x(x-1)^2 y'' = 2y.$

3/4 6. A vibrating string of length π whose displacement y satisfies the equation $\frac{\partial^2 y}{\partial x^2} = \frac{\partial^2 y}{\partial t^2}$ $\checkmark \sin(x)$
 has the initial conditions $y(x, 0) = 2 \sin(x) \cos(x)$ and has zero initial velocity. Find $y(x, t)$ for all x ($0 \leq x \leq \pi$) and all $t \geq 0$.

7/4 7. What is the probability that a random integer n , $1 \leq n \leq 999$, is divisible by both 6 and 10? What is the probability that it is divisible by 6 given that it is divisible by 10?

1

Figure 3.3: Questions page 1

1 ✓ 8. In a family of 3 children, what is the probability that all three are girls $\frac{1}{4}$ given that at least two are girls? What is the probability that all three are girls given that the oldest two are girls? $\frac{1}{2}$

✓ 9. How many solutions are there to the equation

$$a + b + c + d = 20$$

$\frac{1}{2}$ where a, b, c, d are non-negative integers?

✓ $\frac{1}{2}$ 10. If there are an average of two misprints per page of a long book, what is the chance that a given page has no misprints? What is the chance that a given page has at least two misprints?

2

Figure 3.4: Questions page 2

Chapter 4

HWs

Local contents

4.1	HW 1	18
4.2	HW 2	33
4.3	HW 3	54
4.4	HW 4	82
4.5	HW 5	103
4.6	HW 6	125
4.7	HW 7	153
4.8	HW 8	191
4.9	HW 9	228
4.10	HW 10	260
4.11	HW 11	283
4.12	HW 12	296

4.1 HW 1

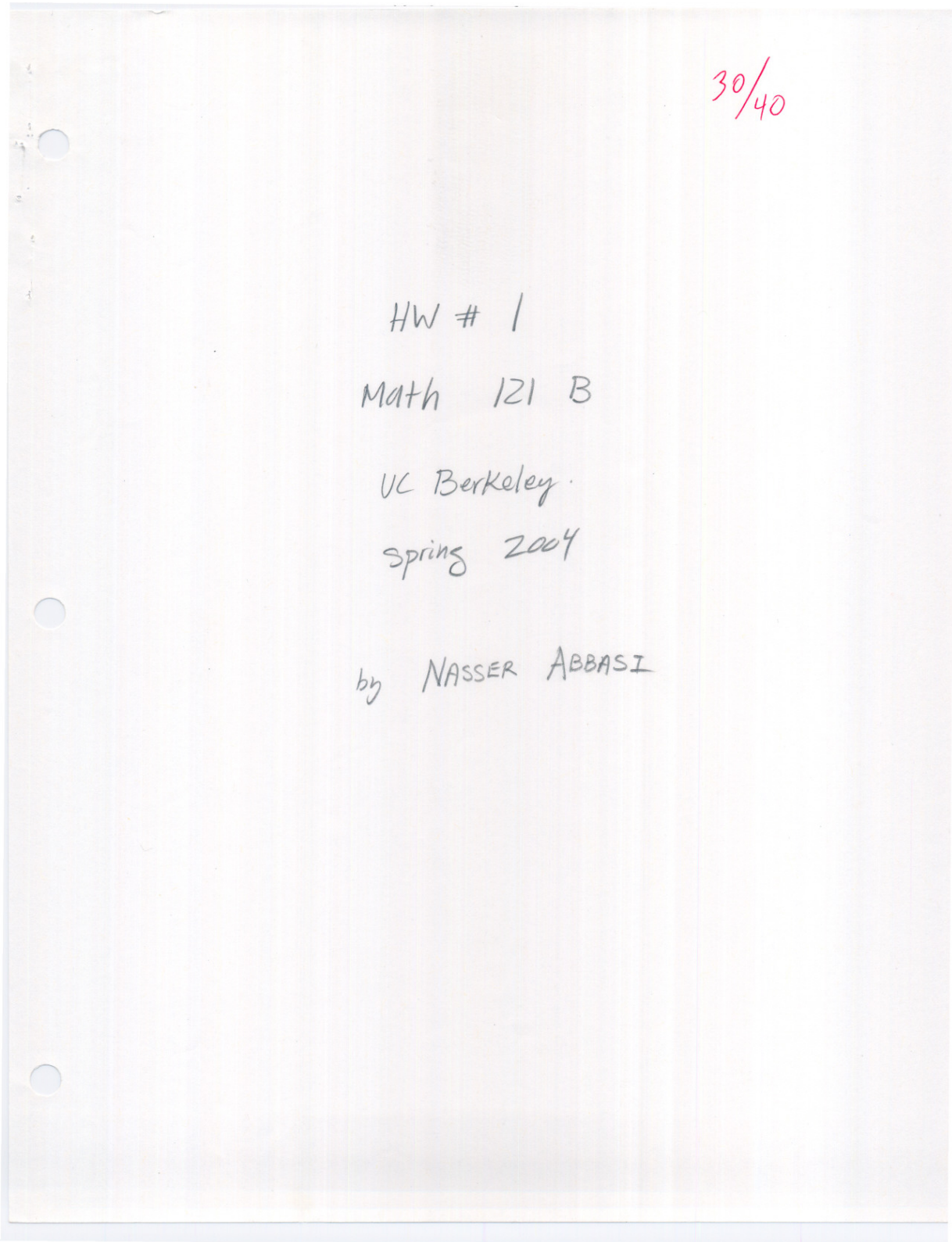

①

problem ch 11, section 3, number 4

Q) Evaluate $\Gamma(5.7)$ using tables and recursion relation $\Gamma(p+1) = p\Gamma(p)$

A) Table for $\Gamma(x)$ is given for $1 \leq x \leq 2$ (using Handbook of Math. Functions by Abramowitz) page 267.

$$\begin{aligned} \text{so } \Gamma(5.7) &= 4.7 \Gamma(4.7) = (4.7)(3.7) \Gamma(3.7) = (4.7)(3.7)(2.7) \Gamma(2.7) \\ &= (4.7)(3.7)(2.7)(1.7) \Gamma(1.7) \end{aligned}$$

from Table, $\Gamma(1.7) = 0.9086387329$

hence $\Gamma(5.7) = 72.52763452395129$

Problem ch 11, section 3, number 8

Q) express the following integral as Γ function and evaluate using table of Γ function

$$\int_0^{\infty} x^{2/3} e^{-x} dx$$

A) since by definition, $\Gamma(p) = \int_0^{\infty} x^{p-1} e^{-x} dx \quad p > 0$

hence here $p-1 = 2/3$ or $\boxed{p = 5/3}$

From Table, There is no value for $\Gamma(5/3)$, but There is a

value for $\Gamma(1.665)$ and $\Gamma(1.670)$. and $\Gamma(5/3)$ is

between These two values. so use interpolation to

find \Rightarrow

$$\Gamma(1.665) = 0.9024728748$$

$$\Gamma(1.670) = 0.9032964995$$

$$\frac{\Gamma(\frac{12}{3}) - \Gamma(1.665)}{\frac{12}{3} - 1.665} = \frac{\Gamma(1.670) - \Gamma(1.665)}{1.670 - 1.665}$$

$$\Gamma(\frac{12}{3}) = \left(\frac{\Gamma(1.670) - \Gamma(1.665)}{1.670 - 1.665} \right) (\frac{12}{3} - 1.665) + \Gamma(1.665)$$

$$\Gamma(\frac{5}{3}) = 0.9027452929509336$$

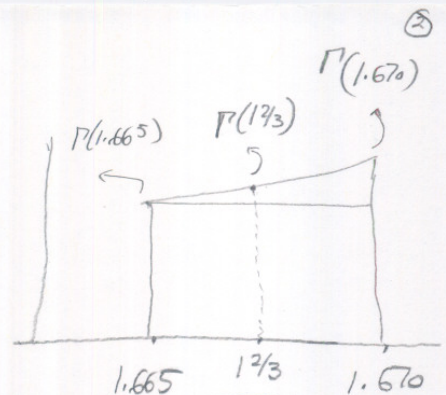

ps. I am assuming constant slope, which is not accurate, but better than using closest value $\Gamma(1.665)$.

③

problem ch 11, section 3, number 13

Q) express following integral as Γ function and evaluate using Tables.

$$\int_0^1 x^2 \left(\ln \frac{1}{x}\right)^3 dx$$

A) let $x = e^{-u}$
 so $dx = -e^{-u} du$

when $x=0 \Rightarrow u = \infty$

when $x=1 \Rightarrow u = 0$

hence integral becomes $I = \int_{\infty}^0 e^{-2u} \left(\ln \frac{1}{e^{-u}}\right)^3 (-e^{-u} du)$

but $\int_{\infty}^0 = -\int_0^{\infty}$, hence

$$I = \int_0^{\infty} e^{-3u} (\ln e^u)^3 du$$

but $\ln e^u = u$

so integral becomes $I = \int_0^{\infty} e^{-3u} u^3 du = \int_0^{\infty} u^3 e^{-3u} du$

to convert to form $\int_0^{\infty} x^{p-1} e^{-x} dx$, let $3u = x$

hence $3du = dx$

when $u=0 \Rightarrow x=0$

when $u=\infty \Rightarrow x=\infty$

$$I = \int_0^{\infty} \left(\frac{x}{3}\right)^3 e^{-x} \frac{dx}{3} = \left(\frac{1}{3}\right)\left(\frac{1}{27}\right) \int_0^{\infty} x^3 e^{-x} dx$$

i.e. $p-1=3$, hence $\Gamma(4) = \int_0^{\infty} x^3 e^{-x} dx \Rightarrow \boxed{I = \left(\frac{1}{3}\right)\left(\frac{1}{27}\right) \Gamma(4)} \Rightarrow$

To find $\Gamma(4)$

$$\Gamma(4) = 3\Gamma(3) = (3)(2)\Gamma(2) = (3)(2)(1)\Gamma(1) = 6$$

$$\text{So } I = \left(\frac{1}{3}\right)\left(\frac{1}{27}\right) 6^2$$

$$= \boxed{\frac{2}{27}}$$

$$= \boxed{0.074074074\dots}$$

(4)

5

Chapter 11, problem 4.5

1) Evaluate the following Γ function using $\Gamma(p) = \frac{1}{p} \Gamma(p+1)$ and tables.

$$\Gamma(-2.3)$$

$$\begin{aligned} \text{1) } \Gamma(-2.3) &= \frac{1}{-2.3} \Gamma(-1.3) \\ &= \left(-\frac{1}{2.3}\right) \left(-\frac{1}{1.3}\right) \Gamma(-.3) \\ &= \left(-\frac{1}{2.3}\right) \left(-\frac{1}{1.3}\right) \left(-\frac{1}{.3}\right) \Gamma(0.7) \\ &= \left(-\frac{1}{2.3}\right) \left(-\frac{1}{1.3}\right) \left(-\frac{1}{.3}\right) \left(\frac{1}{0.7}\right) \underbrace{\Gamma(1.7)}_{\substack{= 0.9086387329 \\ \text{From Table.}}} \end{aligned}$$

$$\text{so } \Gamma(-2.3) = -1.4471073943303074$$

6

Chap 11, problem 4.7

Q) using table of Γ , sketch Γ between 1 and 2; then compute few points and sketch it from -4 to +4.

A) From Table. (look at 1, 1.25, 1.5, 1.75, 2.0)

$$\begin{aligned}\Gamma(1) &= 1 \\ \Gamma(1.25) &= 0.9064 \\ \Gamma(1.5) &= 0.88622 \\ \Gamma(1.75) &= 0.91906 \\ \Gamma(2.0) &= 1\end{aligned}$$

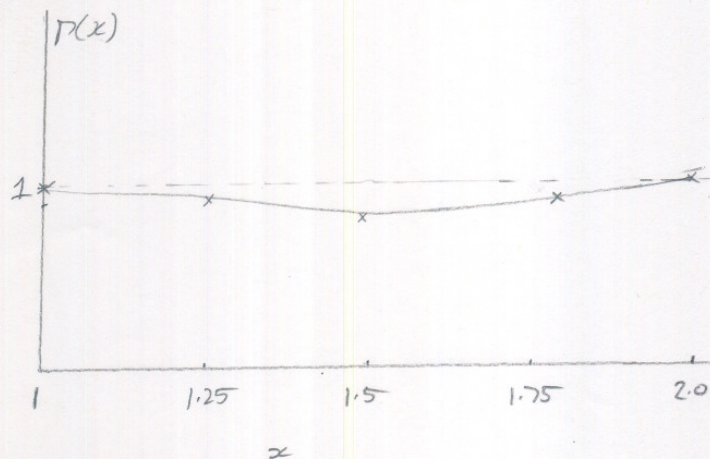

Q) sketch from -4 to +4, find Γ at (.5) intervals.

$$\begin{aligned}\Gamma(4) &= 3\Gamma(3) = (3)(2)\Gamma(2) = 6 \\ \Gamma(3.5) &= 2.5\Gamma(2.5) = (2.5)(1.5)\Gamma(1.5) = (2.5)(1.5)(0.88622) = 3.32335 \\ \Gamma(3) &= 2\Gamma(2) = 2 \\ \Gamma(2) &= 1 \\ \Gamma(1.5) &= 0.88622 \\ \Gamma(1) &= 1 \\ \Gamma(.5) &= \frac{1}{.5}\Gamma(1.5) = \frac{1}{.5} \cdot 0.88622 = 1.77245 \\ \Gamma(0) &= \infty \\ \Gamma(-.5) &= \frac{1}{-.5}\Gamma(.5) = \frac{1}{-.5} \frac{1}{.5}\Gamma(1.5) = \frac{1}{-.5} \frac{1}{.5} \cdot 0.88622 = -3.54491 \\ \Gamma(-1.0) &= \infty \quad (\text{since } \Gamma \text{ has singularities at all negative integers}) \\ \Gamma(-1.5) &= \frac{1}{-1.5}\Gamma(-.5) = \frac{1}{-1.5} \frac{1}{-.5} \Gamma(.5) = \frac{1}{-1.5} \frac{1}{-.5} \frac{1}{.5}\Gamma(1.5) = 2.36327 \\ \Gamma(-2) &= \infty \\ \Gamma(-2.5) &= \frac{1}{-2.5}\Gamma(-1.5) = \frac{1}{-2.5} \frac{1}{-1.5} \Gamma(-.5) = \frac{1}{-2.5} \frac{1}{-1.5} \frac{1}{-.5}\Gamma(.5) \\ &= \frac{1}{-2.5} \frac{1}{-1.5} \frac{1}{-.5} \frac{1}{.5}\Gamma(1.5) \\ &= -0.945309\end{aligned}$$

$$\Gamma(-3) = \infty$$

$$\Gamma(-3.5) = \frac{1}{-3.5} \Gamma(-2.5) = \frac{1}{-3.5} \frac{1}{-2.5} \Gamma(-1.5)$$

= 2.36327 from above

$$\Gamma(-4) = \infty$$

$$= 0.27$$

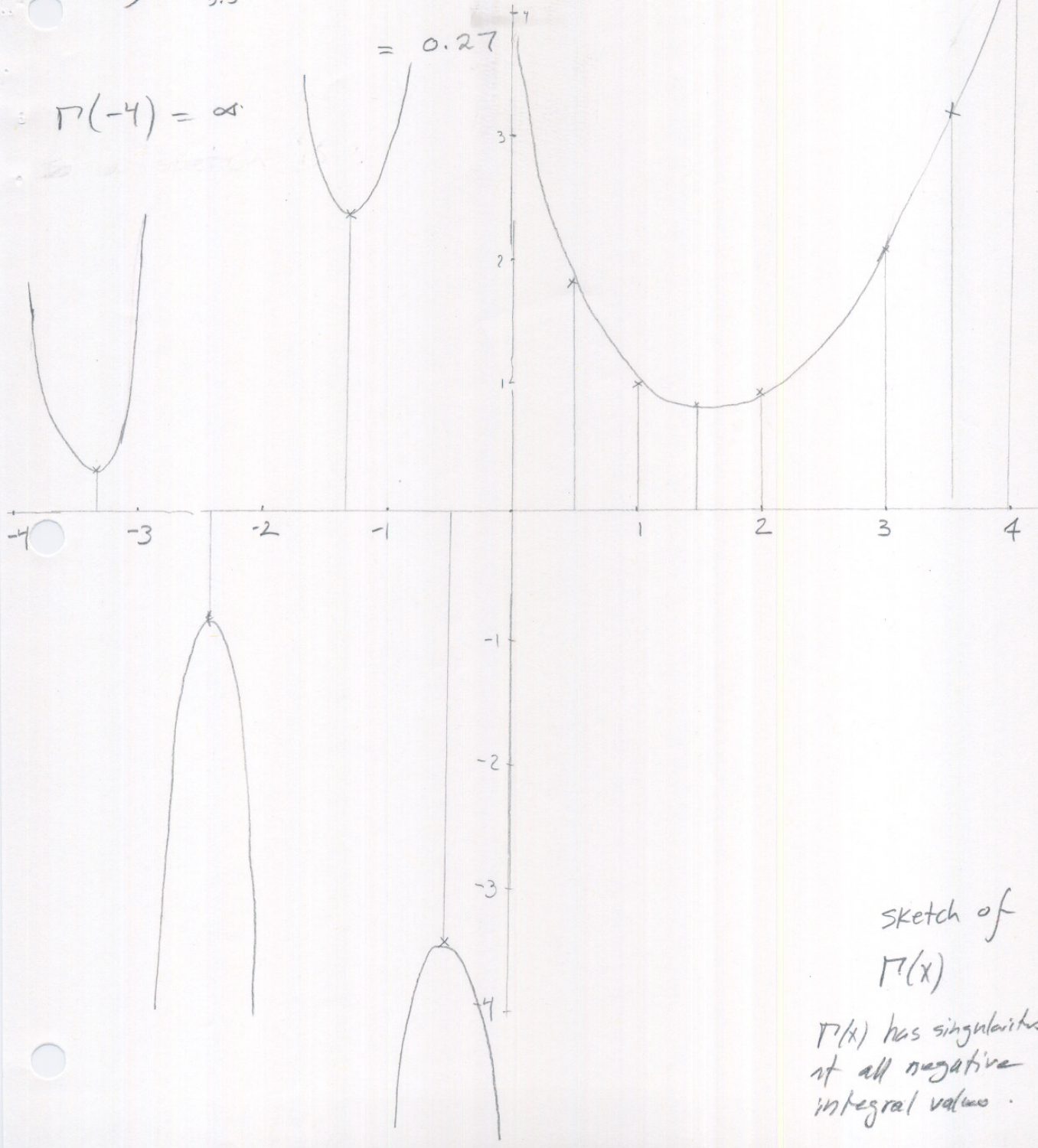

Sketch of $\Gamma(x)$

$\Gamma(x)$ has singularities at all negative integral values.

chapter 11, 5.1

⑧

prove that for positive integral n

$$\Gamma\left(n+\frac{1}{2}\right) = \frac{1 \cdot 3 \cdot 5 \cdots (2n-1)}{2^n} \sqrt{\pi} = \frac{(2n)!}{4^n n!} \sqrt{\pi}$$

since n is positive integral, then use

$$\Gamma(p+1) = p\Gamma(p) \quad \text{to expand } \Gamma\left(n+\frac{1}{2}\right).$$

So $\Gamma\left(n+\frac{1}{2}\right) = \left(n-\frac{1}{2}\right) \Gamma\left(n-\frac{1}{2}\right)$

apply again to expand $\Gamma\left(n-\frac{1}{2}\right)$

$$\Gamma\left(n-\frac{1}{2}\right) = \left(n-\frac{3}{2}\right) \Gamma\left(n-\frac{3}{2}\right)$$

$$\Gamma\left(n-\frac{3}{2}\right) = \left(n-\frac{5}{2}\right) \Gamma\left(n-\frac{5}{2}\right)$$

continue until we get to $\Gamma\left(1-\frac{1}{2}\right)$ which is $\frac{1}{2} \Gamma\left(\frac{1}{2}\right)$

hence

$$\Gamma\left(n+\frac{1}{2}\right) = \overbrace{\left(n-\frac{1}{2}\right) \left(n-\frac{3}{2}\right) \left(n-\frac{5}{2}\right) \cdots \left(\frac{1}{2}\right)}^{n \text{ times}} \Gamma\left(\frac{1}{2}\right)$$

for example, for $n=4$ 4 terms

$$\Gamma\left(4+\frac{1}{2}\right) = \left(3\frac{1}{2}\right) \left(2\frac{1}{2}\right) \left(1\frac{1}{2}\right) \left(\frac{1}{2}\right) \Gamma\left(\frac{1}{2}\right)$$

$$\text{So } \Gamma\left(n+\frac{1}{2}\right) = \frac{(2n-1)}{2} \frac{(2n-3)}{2} \frac{(2n-5)}{2} \cdots \frac{1}{2} \Gamma\left(\frac{1}{2}\right)$$

$$= \frac{(2n-1)(2n-3)(2n-5) \cdots (1)}{2^n} \Gamma\left(\frac{1}{2}\right)$$

$$= \frac{(1)(3) \cdots (2n-5)(2n-3)(2n-1)}{2^n} \Gamma\left(\frac{1}{2}\right) \Rightarrow$$

$$= \frac{1 \cdot 3 \cdot 5 \cdots (2n-3) \cdot (2n-1)}{2^n} \sqrt{\pi} \quad \text{--- (1)}$$

now need to show that $\frac{1 \cdot 3 \cdot 5 \cdots (2n-1)}{2^n} \Rightarrow \frac{(2n)!}{4^n n!}$

$$\text{now } 1 \cdot 2 \cdot 3 \cdot 4 \cdot 5 \cdots (2n-3)(2n-2)(2n-1)(2n) = (2n)!$$

$$\text{so } \frac{(2n)!}{2 \cdot 4 \cdot 6 \cdot 8 \cdots (2n-2)(2n)} = 1 \cdot 3 \cdot 5 \cdots (2n-1) \quad \text{--- (2)}$$

$$\text{but } 2 \cdot 4 \cdot 6 \cdot 8 \cdots (2n-2)(2n) = 2 [1 \cdot 2 \cdot 3 \cdot 4 \cdots n] \quad \text{by factoring 2 out.}$$

$$= 2 n!$$

hence from (2)

$$\frac{(2n)!}{2 n!} = 1 \cdot 3 \cdot 5 \cdots (2n-1)$$

sub the above back into equation (1), I set

$$\frac{\frac{(2n)!}{2 n!}}{2^n} \sqrt{\pi}$$

$$\text{or } \left[\frac{(2n)!}{4^n n!} \sqrt{\pi} = \Gamma\left(n + \frac{1}{2}\right) \right]$$

QED

Chapter 11, problem ~~12.1~~ ^{6.1}

(10)

1) Prove that $B(p, q) = B(q, p)$

hint: Put $x = 1 - y$

by definition

$$B(p, q) = \int_0^1 x^{p-1} (1-x)^{q-1} dx$$

$p > 0 \quad q > 0$ — (1)

so need to show that $\int_0^1 x^{p-1} (1-x)^{q-1} dx \equiv \int_0^1 x^{q-1} (1-x)^{p-1} dx$.

let $x = 1 - y$ in (1)

$$dx = -dy$$

when $x = 0 \Rightarrow y = 1$

when $x = 1 \Rightarrow y = 0$

so (1) becomes $\int_1^0 (1-y)^{p-1} (1-(1-y))^{q-1} (-dy)$

$$= \int_1^0 (1-y)^{p-1} (y)^{q-1} (-dy) = \int_0^1 (1-y)^{p-1} y^{q-1} dy \text{ — (2)}$$

but y is a dummy variable, so in (2), rewrite ' y ' as ' x '

$$= \int_0^1 x^{q-1} (1-x)^{p-1} dx \text{ — (3)}$$

but (3) is definition of $B(q, p)$. hence

$$B(p, q) = B(q, p)$$

QED

problem chapter 11, 6.2 ①

Q) prove $B(p, q) = \int_0^{\infty} \frac{y^{p-1}}{(1+y)^{p+q}} dy$. ①

from definition $B(p, q) = \int_0^1 x^{p-1} (1-x)^{q-1} dx$ $p > 0$ $q > 0$.

let $x = \frac{y}{1+y}$ into above equation:

when $x = 0 \Rightarrow y = 0$

when $x = 1 \Rightarrow \frac{y}{1+y} = 1$ i.e. $y = \infty$

$$\begin{aligned} \frac{dx}{dy} &= \frac{d}{dy} (y)(1+y)^{-1} = 1(1+y)^{-1} + y(-1)(1+y)^{-2} = \frac{1}{(1+y)} - \frac{y}{(1+y)^2} \\ &= \frac{1+y-y}{(1+y)^2} = \frac{1}{(1+y)^2} \end{aligned}$$

so $dx = \frac{1}{(1+y)^2} dy$

$$\begin{aligned} B(p, q) &= \int_0^{\infty} \left(\frac{y}{1+y}\right)^{p-1} \left(1 - \frac{y}{1+y}\right)^{q-1} \frac{1}{(1+y)^2} dy \\ &= \int_0^{\infty} \frac{y^{p-1}}{(1+y)^{p-1}} \left(\frac{1+y-y}{1+y}\right)^{q-1} \frac{1}{(1+y)^2} dy = \int_0^{\infty} \frac{y^{p-1}}{(1+y)^{p-1}} \frac{1}{(1+y)^{q-1}} \frac{1}{(1+y)^2} dy \\ &= \int_0^{\infty} \frac{y^{p-1}}{(1+y)^{p-1+q-1+2}} dy = \int_0^{\infty} \frac{y^{p-1}}{(1+y)^{p+q}} dy \end{aligned}$$

QED

problem ch 11, 7.3

(12)

express following integral as β function, here in terms of Γ functions, and evaluate from tables.

$$I = \int_0^1 \frac{dx}{\sqrt{1-x^3}} = \int_0^1 \frac{dx}{(1-x^3)^{1/2}} = \int_0^1 (1-x^3)^{-\frac{1}{2}} dx$$

$$\text{Compare to } \beta(p, q) = \int_0^1 x^{p-1} (1-x)^{q-1} dx \quad \text{--- (1)}$$

$$\text{let } x^3 = y \quad \checkmark$$

$$\text{so } x = y^{1/3} \Rightarrow dx = \frac{1}{3} y^{-2/3} dy$$

$$\text{when } x=0 \Rightarrow y=0$$

$$\text{when } x=1 \Rightarrow y=1$$

$$\text{so } \int_0^1 (1-x^3)^{-1/2} dx = \int_0^1 (1-y)^{-1/2} \frac{1}{3} y^{-2/3} dy = \frac{1}{3} \int_0^1 y^{-2/3} (1-y)^{-1/2} dy$$

since y is dummy variable, rewrite as

$$I = \frac{1}{3} \int_0^1 x^{-2/3} (1-x)^{-1/2} dx \quad \text{compare to (1)}$$

$$\text{hence need } p-1 = -\frac{2}{3} \quad \text{and } q-1 = -\frac{1}{2}$$

$$\text{i.e. } p = \frac{1}{3} \quad \text{and } q = \frac{1}{2}$$

$$\text{hence } I = \frac{1}{3} \beta(p, q) = \frac{1}{3} \beta\left(\frac{1}{3}, \frac{1}{2}\right) = \frac{1}{3} \frac{\Gamma\left(\frac{1}{3}\right) \Gamma\left(\frac{1}{2}\right)}{\Gamma\left(\frac{1}{3} + \frac{1}{2}\right)}$$

$$= \frac{1}{3} \frac{\Gamma\left(\frac{1}{3}\right) \Gamma\left(\frac{1}{2}\right)}{\Gamma\left(\frac{5}{6}\right)}, \text{ but } \Gamma\left(\frac{1}{3}\right) = \frac{1}{\sqrt{3}} \Gamma\left(\frac{4}{3}\right) \text{ so } \Rightarrow$$

$$\frac{1}{13} \Gamma\left(\frac{4}{3}\right), \Gamma\left(\frac{1}{2}\right) \quad \Gamma\left(\frac{4}{3}\right) \sqrt{\pi}$$

From Tables, $\Gamma\left(\frac{4}{3}\right) \cong \Gamma(1.335) = 0.89278$

$$\Gamma\left(\frac{5}{6}\right) = \frac{1}{56} \Gamma\left(\frac{11}{6}\right) = \frac{6}{5} \underbrace{\Gamma(1.8333)}_{\cong 0.93969}$$

so $I = 1.403$ ✓

p.s. To get more accurate result need to use interpolation to find $\Gamma(x)$ for x values not in table. here I used closest value in Table instead.

problem chapter 11, 7.7

(14)

- Q) Express following integral as β function, hence in terms of Γ functions and evaluate using Table

$$I = \int_0^{\pi/2} \frac{d\theta}{\sqrt{\sin \theta}} = \int_0^{\pi/2} (\sin \theta)^{-1/2} d\theta \quad \text{--- (1)}$$

The trig. Form of Beta function is

$$B(p, q) = 2 \int_0^{\pi/2} (\sin \theta)^{2p-1} (\cos \theta)^{2q-1} d\theta$$

Compare with (1).

need $2p-1 = -\frac{1}{2}$, $2q-1 = 0$

hence $p = \frac{-\frac{1}{2} + 1}{2} = .25$, $q = \frac{1}{2}$

so $I = \frac{1}{2} B(p, q) = \frac{1}{2} B(.25, .5)$

$$I = \frac{1}{2} \frac{\Gamma(.25) \Gamma(.5)}{\Gamma(.75)} = \frac{1}{2} (2.62206) = 1.31103$$

$$\Gamma(.25) = \frac{1}{.25} \Gamma(1.25) = 4 \Gamma(1.25) = 4 (0.9064)$$

$$\Gamma(.75) = \frac{1}{.75} \Gamma(1.75) = \frac{1}{.75} (0.91906)$$

hence $I = 2.62206$

7.9?
11.2?
11.5?

11.8?
11.9?

4.2 HW 2

35/
40

HW # 2

Math 121 B

Nasser Abbasi

(Extension student)

Ch 11

①

9.1

sketch $y = e^{-x^2}$

$$e = 2.718$$

look at few points.

x	y
0	1
+1	$1/e = .367$
+2	$1/e^4 = .018$
+3	$1/e^9 = .00012$
-1	$1/e = .367$
-2	$1/e^4 = .018$
-3	$1/e^9 = .00012$

the same since x^2

so plot is

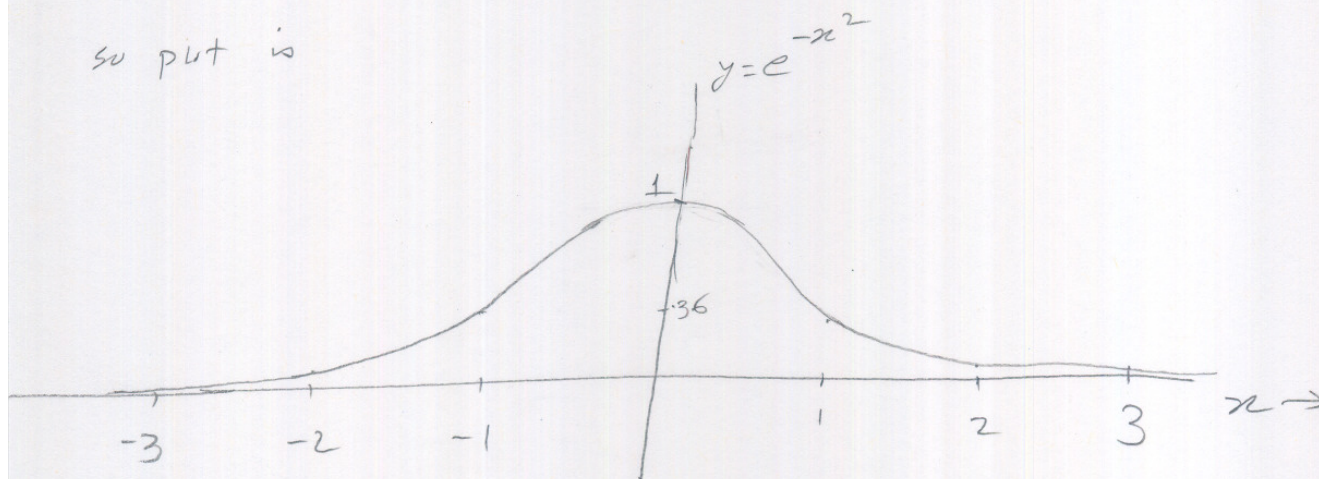

notice how quickly y approaches zero on each side due to the e^{x^2} being in the denominator.

ch 11

9.3

prove that $\text{erf}(x)$ is an odd function of x .

$$\text{erf}(x) = \frac{2}{\sqrt{\pi}} \int_0^x e^{-t^2} dt$$

a function is odd if $f(-x) = -f(x)$ and even if $f(-x) = f(x)$.

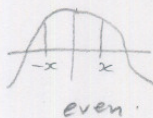
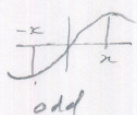

So need to show that $\text{erf}(-x) = -\text{erf}(x)$

$$\text{erf}(-x) = \frac{2}{\sqrt{\pi}} \int_0^{-x} e^{-t^2} dt$$

$$\text{but } \int_a^b = -\int_b^a$$

let $t = -s$

$$dt = -ds$$

$$\text{when } t=0 \Rightarrow s=0$$

$$\text{when } t=-x \Rightarrow s=x$$

$$\text{so } \text{erf}(-x) = \frac{2}{\sqrt{\pi}} \int_0^x e^{-(-s)^2} (-ds)$$

$$\text{erf}(-x) = -\frac{2}{\sqrt{\pi}} \int_0^x e^{-s^2} ds$$

since 's' is a dummy variable, I can rewrite above as

$$\text{erf}(-x) = -\frac{2}{\sqrt{\pi}} \int_0^x e^{-t^2} dt = -\text{erf}(x)$$

hence odd.

Ch 11

9.4 Show that $I = \int_{-\infty}^{\infty} e^{-\frac{y^2}{2}} dy = \sqrt{2\pi}$

(a) by using 9.5 and 9.2 a

(b) by reducing it to a Γ function and using 5.3

Dr I show part (b) first (since easier)

(b)



First let $y = \sqrt{2}t \Rightarrow dy = \sqrt{2} dt$

$$y = -\infty \Rightarrow t = -\infty$$

$$y = +\infty \Rightarrow t = +\infty$$

$$\text{so } I = \int_{-\infty}^{\infty} e^{-\frac{1}{2}(\sqrt{2}t)^2} \sqrt{2} dt \Rightarrow \sqrt{2} \int_{-\infty}^{\infty} e^{-t^2} dt$$

since $\int e^{-t^2}$ is even, then $\int_{-\infty}^{\infty} e^{-t^2} dt = 2 \int_0^{\infty} e^{-t^2} dt$

$$\text{so } I = 2\sqrt{2} \int_0^{\infty} e^{-t^2} dt \quad \text{but } \int_0^{\infty} e^{-t^2} dt = \frac{1}{2} \Gamma\left(\frac{1}{2}\right) = \frac{1}{2} \sqrt{\pi}$$

$$\text{so } I = 2\sqrt{2} \frac{\sqrt{\pi}}{2} = \boxed{\sqrt{2\pi}}$$

(a) from 9.2 (a) $P(-\infty, x)$ is given. so I replace x with zero to get

$$P(-\infty, 0) = \frac{1}{\sqrt{2\pi}} \int_{-\infty}^0 e^{-t^2/2} dt = \frac{1}{2} + \frac{1}{2} \operatorname{erf}\left(\frac{0}{\sqrt{2}}\right) = \frac{1}{2} \quad \text{since } \operatorname{erf}(0) = 0$$

and from 9.2 (b), put $x = +\infty$ to get:

$$P(0, +\infty) = \frac{1}{\sqrt{2\pi}} \int_0^{+\infty} e^{-t^2/2} dt = \frac{1}{2} \operatorname{erf}\left(\frac{\infty}{\sqrt{2}}\right) = \frac{1}{2} \quad \text{since } \operatorname{erf}(\infty) = 1 \text{ by definition.}$$

since $P(-\infty, 0) + P(0, +\infty) = P(\infty)$

hence from (9.5) $P(-\infty, 0) + P(0, +\infty) = 1$

$$\text{hence } \frac{1}{\sqrt{2\pi}} \int_{-\infty}^0 e^{-t^2/2} dt + \frac{1}{\sqrt{2\pi}} \int_0^{\infty} e^{-t^2/2} dt = 1 \Rightarrow \boxed{\int_{-\infty}^{\infty} e^{-t^2/2} dt = \sqrt{2\pi}}$$

Ch 11

$$\boxed{10.3} \quad \int_0^2 e^{-x^2} dx.$$

(4)

$$\operatorname{erf}(2) = \frac{2}{\sqrt{\pi}} \int_0^2 e^{-x^2} dx \quad \text{by definition}$$

$$\text{hence } \int_0^2 e^{-x^2} dx = \frac{\sqrt{\pi}}{2} \operatorname{erf}(2).$$

From Table, $\operatorname{erf}(2) = 0.9953222650$

$$\text{and } \frac{\sqrt{\pi}}{2} = 0.8862269255$$

$$\text{hence } \int_0^2 e^{-x^2} dx = \boxed{0.88208139079}$$

$$\boxed{10.5} \quad \text{Find } \operatorname{erfc}(5)$$

$$\operatorname{erfc}(5) = 1 - \operatorname{erf}(5)$$

Table for $\operatorname{erf}(x)$ only goes up to 2. however Table 7.3 in handbook of math. Functions, Abramowitz, Page 316, contain Table for $\operatorname{erfc}(x)$ for $x=5$.

using Table entry for $\frac{1}{x^2} = 0.04$, then

$$\text{for } x=5 : \quad x e^{x^2} \operatorname{erfc}(x) = 0.5535232$$

$$\text{hence } \operatorname{erfc}(5) = \frac{0.5535232}{5 e^{25}} = \boxed{1.53746 \times 10^{-12}}$$

ch 11

⑤

10.13 by repeated integration by parts, find several terms of the asymptotic series for

$$I = \int_x^\infty t^{n-1} e^{-t} dt$$

$$t^{n-1} e^{-t} = t^{n-1} \frac{d}{dt} (-e^{-t})$$

so let $u = t^{n-1}$, $dv = -e^{-t}$ and apply $\int u dv = uv - \int v du$

$$\text{hence } I = \underbrace{t^{n-1} (-e^{-t})}_x^\infty - \int_x^\infty (n-1) t^{n-2} (-e^{-t}) dt$$

→ looking at this alone

$$\lim_{t \rightarrow \infty} \left(-\frac{t^{n-1}}{e^t} \right) + \frac{x^{n-1}}{e^x}$$

$$\lim_{t \rightarrow \infty} \left(\frac{t^{n-1}}{e^t} \right) = 0$$

I can show this by expanding e^t as power series and then dividing by t^{n-1} both numerator and denominator:

$$\begin{aligned} \frac{t^{n-1}}{1+t+\frac{t^2}{2!}+\frac{t^3}{3!}+\dots} &= \frac{1}{\frac{1}{t^{n-1}} + \frac{t}{t^{n-1}} + \frac{t^2}{2! t^{n-1}} + \frac{t^3}{3! t^{n-1}} + \dots + \frac{t^{n-2}}{(n-2)! t^{n-1}} + \frac{t^{n-1}}{(n-1)! t^{n-1}} + \frac{t^n}{n! t^{n-1}} + \dots} \\ &= \frac{1}{\frac{1}{t^{n-1}} + \frac{1}{t^{n-2}} + \frac{1}{2! t^{n-3}} + \frac{1}{3! t^{n-4}} + \dots + \frac{1}{(n-2)! t} + \frac{1}{(n-1)!} + \frac{t}{n!} + \frac{t^2}{(n+1)!} + \dots} \end{aligned}$$

now let $t \rightarrow \infty$ we get

$$\begin{aligned} &= \frac{1}{\frac{1}{\infty} + \frac{1}{\infty} + \frac{1}{\infty} + \frac{1}{\infty} + \dots + \frac{1}{(n-1)!} + \infty + \infty + \infty + \dots} \\ &= \frac{1}{0+0+0+0+\dots + \frac{1}{(n-1)!} + \infty} = \frac{1}{\infty} = 0 \Rightarrow \end{aligned}$$

So this means

$$I = \int_x^\infty t^{n-1} (-e^{-t}) dt - \int_x^\infty (n-1)t^{n-2} (-e^{-t}) dt$$

$$= \left(0 + \frac{x^{n-1}}{e^x} \right) + (n-1) \int_x^\infty t^{n-2} e^{-t} dt.$$

apply integration by parts again to $\int_x^\infty t^{n-2} e^{-t} dt$ set

$$= \frac{x^{n-1}}{e^x} + (n-1) \left[\left(0 + \frac{x^{n-2}}{e^x} \right) + (n-2) \int_x^\infty t^{n-3} e^{-t} dt \right]$$

$$= \frac{x^{n-1}}{e^x} + (n-1) \left[\frac{x^{n-2}}{e^x} + (n-2) \int_x^\infty t^{n-3} e^{-t} dt \right]$$

$$= \frac{x^{n-1}}{e^x} + \frac{(n-1)x^{n-2}}{e^x} + (n-1)(n-2) \left[\frac{x^{n-3}}{e^x} + (n-3) \int_x^\infty t^{n-4} e^{-t} dt \right]$$

$$= \frac{x^{n-1}}{e^x} + \frac{(n-1)x^{n-2}}{e^x} + \frac{(n-1)(n-2)x^{n-3}}{e^x} + (n-1)(n-2)(n-3) \left[\frac{x^{n-4}}{e^x} + (n-4) \int_x^\infty t^{n-5} e^{-t} dt \right]$$

$$= \frac{x^{n-1}}{e^x} \left(1 + \frac{(n-1)}{x} + \frac{(n-1)(n-2)}{x^2} + \frac{(n-1)(n-2)(n-3)}{x^3} + \dots \right)$$

$$+ \frac{(n-1)(n-2)\dots(n-(n+1))}{(n-1)!} \int_x^\infty t^{n-n} e^{-t} dt$$

\downarrow
 $\int_x^\infty e^{-t} dt$

$$= \frac{x^{n-1}}{e^x} \left(1 + \frac{(n-1)}{x} + \frac{(n-1)(n-2)}{x^2} + \dots + \frac{(n-1)(n-2)\dots(2)}{x^{n-2}} \right) + (n-1)! \int_x^\infty e^{-t} dt \quad (7)$$

$$\text{but } \int_x^\infty e^{-t} dt = -e^{-t} \Big|_x^\infty = -e^{-\infty} + e^{-x} = \frac{1}{e^x}$$

$$\text{hence } I = \frac{x^{(n-1)}}{e^x} \left(1 + \frac{(n-1)}{x} + \dots + \frac{(n-1)(n-2)\dots(2)}{x^{n-2}} \right) + \frac{(n-1)!}{e^x}$$

To verify if $x=0$ then we set

$$0 + \frac{(n-1)!}{e^0} = \boxed{(n-1)! = \Gamma(n)}$$

as expected. ok.

Dr note on my solution. after I solved this I found in the back of book it gives solution the same but without the $\frac{(n-1)!}{e^x}$ term.

$$\text{ie book says } \int_x^\infty t^{n-1} e^{-t} dt = \frac{x^{n-1}}{e^x} \left[1 + \frac{(n-1)}{x} + \dots \right] \quad (1)$$

however, book also says that when $x=0$, we should get the Gamma function $\Gamma(n)$. (page 472). however, if I put $x=0$ in (1), I get 0. while in my solution,

I do get $\Gamma(n)$ due to the extra term $\frac{(n-1)!}{e^x}$.

did I overlook something?

ch 11

10.14

express error function as incomplete Γ function.I'll start with the sequence for $\Gamma(n, x)$ obtained from 10.13

$$\Gamma(n, x) = \frac{x^{n-1}}{e^x} \left(1 + \frac{(n-1)}{x} + \frac{(n-1)(n-2)}{x^2} + \frac{(n-1)(n-2)(n-3)}{x^3} + \dots \right)$$

put $n = \frac{1}{2}$, and sub $x = y^2$ we get

$$\begin{aligned} \Gamma\left(\frac{1}{2}, y^2\right) &= \frac{y^{2(\frac{1}{2}-1)}}{e^{y^2}} \left(1 + \frac{-\frac{1}{2}}{y^2} + \frac{(-\frac{1}{2})(-\frac{3}{2})}{y^4} + \frac{(-\frac{1}{2})(-\frac{3}{2})(-\frac{5}{2})}{y^6} + \dots \right) \\ &= \frac{1}{y e^{y^2}} \left(1 - \frac{1}{2y^2} + \frac{3}{4y^4} - \frac{3 \times 5}{8y^6} + \dots \right) \\ &= \frac{1}{y e^{y^2}} \left(1 - \frac{1}{2y^2} + \frac{3}{(2y^2)^2} - \frac{3 \times 5}{(2y^2)^3} + \dots \right) \end{aligned}$$

the expression on the R.H.S. is $\sqrt{\pi} \operatorname{erfc}(y)$ by looking at 10.4 on page 469. ✓ OK.

hence $\Gamma\left(\frac{1}{2}, y^2\right) = \sqrt{\pi} \operatorname{erfc}(y)$

since y now is a dummy variable
I can rewrite as x .

hence $\Gamma\left(\frac{1}{2}, x^2\right) = \sqrt{\pi} \operatorname{erfc}(x) = \sqrt{\pi} (1 - \operatorname{erf}(x))$

so $\operatorname{erf}(x) = 1 - \frac{\Gamma\left(\frac{1}{2}, x^2\right)}{\sqrt{\pi}}$ ✓

Ch 11

12.1

Expand $F(k, \phi)$ and $E(k, \phi)$ in power series in $k^2 \sin^2 \phi$ for small k and integrate term by term. From these series find series for the complete elliptic integrals K and E . (9)

$$F(k, \phi) = \int_0^{\phi} \frac{d\phi}{\sqrt{1 - k^2 \sin^2 \phi}} \quad 0 \leq k \leq 1$$

Since $0 \leq k \leq 1$, then $k^2 \sin^2 \phi \leq 1$ (since $\max \sin \phi = 1$)
 hence can expand using binomial theorem $(1-x)^p$, where
 here $p = -\frac{1}{2}$ and $x = (k \sin \phi)^2$

$$\text{i.e. } F(k, \phi) = \int_0^{\phi} \underbrace{(1 - (k \sin \phi)^2)^{-\frac{1}{2}}}_{\downarrow \text{expand this}} d\phi$$

$$(1-x)^{-\frac{1}{2}} = 1 + \frac{1}{2}x + \frac{1 \cdot 3}{2 \cdot 4}x^2 + \frac{1 \cdot 3 \cdot 5}{2 \cdot 4 \cdot 6}x^3 + \frac{1 \cdot 3 \cdot 5 \cdot 7}{2 \cdot 4 \cdot 6 \cdot 8}x^4 + \dots$$

I will use the first 4 terms, hence

$$= 1 + \frac{1}{2}(k \sin \phi)^2 + \frac{1 \cdot 3}{2 \cdot 4}(k \sin \phi)^4 + \frac{1 \cdot 3 \cdot 5}{2 \cdot 4 \cdot 6}(k \sin \phi)^6 + \dots$$

$$\text{So } F(k, \phi) = \int_0^{\phi} d\phi + \frac{1}{2} \int_0^{\phi} (k \sin \phi)^2 d\phi + \frac{1 \cdot 3}{2 \cdot 4} \int_0^{\phi} (k \sin \phi)^4 d\phi + \frac{1 \cdot 3 \cdot 5}{2 \cdot 4 \cdot 6} \int_0^{\phi} (k \sin \phi)^6 d\phi$$

Since k is a parameter not dependent on ϕ , take outside \int ,

$$F(k, \phi) = \int_0^{\phi} d\phi + \frac{k^2}{2} \int_0^{\phi} \sin^2 \phi d\phi + \frac{1 \cdot 3}{2 \cdot 4} k^4 \int_0^{\phi} \sin^4 \phi d\phi + \frac{1 \cdot 3 \cdot 5}{2 \cdot 4 \cdot 6} k^6 \int_0^{\phi} \sin^6 \phi d\phi$$

now integrate each term:

$$\int_0^{\phi} d\phi = \boxed{\phi}$$

$$\frac{k^2}{2} \int_0^{\phi} \sin^2 \phi d\phi = \frac{k^2}{2} \left[\int_0^{\phi} \frac{1 - \cos(2\phi)}{2} d\phi = \int_0^{\phi} \frac{1}{2} d\phi - \frac{1}{2} \int_0^{\phi} \cos 2\phi d\phi \right]$$

$$= \frac{k^2}{2} \left(\frac{1}{2}(\phi) - \frac{1}{2}(\cos \phi \sin \phi) \right) = \boxed{\frac{k^2}{4} \phi - \frac{k^2}{4} \cos \phi \sin \phi} \rightarrow$$

(10)

Third term

$$\frac{1.3}{2.4} K^4 \int_0^\phi \sin^4 \phi \, d\phi = \frac{1.3}{2.4} K^4 \int_0^\phi (\sin^2 \phi)^2 \, d\phi$$

$$\text{but } \sin^2 \phi = \frac{1 - \cos 2\phi}{2} \quad \text{so} \quad \frac{1.3}{2.4} K^4 \int_0^\phi \left(\frac{1 - \cos 2\phi}{2} \right)^2 \, d\phi$$

$$= \frac{1.3}{2.4} K^4 \int_0^\phi \frac{1}{4} (1 - 2\cos 2\phi + \cos^2 \phi) \, d\phi$$

$$= \frac{1.3}{2.4} \frac{1}{4} K^4 \left(\int_0^\phi 1 \, d\phi - 2 \int_0^\phi \cos 2\phi + \int_0^\phi \cos^2 \phi \right)$$

$$= \frac{1.3}{2.4} \frac{1}{4} K^4 \left(\phi - 2 \cos \phi \sin \phi + \int_0^\phi \frac{1 + \cos 2\phi}{2} \, d\phi \right)$$

$$= \frac{1.3}{2.4} \frac{1}{4} K^4 \left(\phi - 2 \cos \phi \sin \phi + \int_0^\phi \frac{1}{2} \, d\phi + \int_0^\phi \cos 2\phi \, d\phi \right)$$

$$= \frac{1.3}{2.4} \frac{1}{4} K^4 \left(\phi - 2 \cos \phi \sin \phi + \frac{1}{2} \phi + \cos \phi \sin \phi \right)$$

$$= \frac{1.3}{2.4} \frac{1}{4} K^4 \phi - \frac{1.3}{2.4} \frac{2}{4} K^4 \cos \phi \sin \phi + \frac{1.3}{2.4} \frac{1}{4} \frac{1}{2} K^4 \phi + \frac{1.3}{2.4} \frac{1}{4} K^4 \cos \phi \sin \phi$$

$$= \frac{3}{32} K^4 \phi - \frac{3}{16} K^4 \cos \phi \sin \phi + \frac{3}{64} K^4 \phi + \frac{3}{32} K^4 \cos \phi \sin \phi$$

$$= \frac{9}{64} K^4 \phi - \frac{3}{32} K^4 \cos \phi \sin \phi$$

we can continue as this for $\int \sin^6 \phi \, d\phi$. stopping here, I get

$$F(K, \phi) = \phi + \frac{K^2}{4} \phi - \frac{K^2}{4} \cos \phi \sin \phi + \frac{9}{64} K^4 \phi - \frac{3}{32} K^4 \cos \phi \sin \phi \dots$$

before I continue to $E(K, \phi)$, I verify the above is OK \rightarrow

from Tables, $F(k, \phi)$ for $k=0.5$ and $\phi = \frac{\pi}{4}$ is 0.804366 ⁽¹⁾

using series expansion:

$$\frac{\pi}{4} + \frac{.5^2}{4} \frac{\pi}{4} - \frac{.5^2}{4} \cos \frac{\pi}{4} \sin \frac{\pi}{4} + \frac{9}{64} \cdot .5^4 \frac{\pi}{4} - \frac{3}{32} \cdot .5^4 \cos \frac{\pi}{4} \sin \frac{\pi}{4}$$

$$\Rightarrow \boxed{\cancel{0.82504}} \quad \boxed{0.77153}$$

This is a good approximation considering I only used 3 terms in the expansion. error is about 2.5%.

Now I will do the expansion for $E(k, \phi)$.

$$E(k, \phi) = \int_0^{\phi} \sqrt{1 - k^2 \sin^2 \theta} d\theta$$

Similarly, expand $(1-x)^p$ using binomial theory, where here $p = \frac{1}{2}$ not $-\frac{1}{2}$ as was the case with $F(k, \phi)$.

$$(1-x)^p = (1-x)^{\frac{1}{2}} = 1 - \frac{1}{2}x - \frac{1 \cdot 1}{2 \cdot 4} x^2 - \frac{1 \cdot 1 \cdot 3}{2 \cdot 4 \cdot 6} x^3 - \dots$$

where $x = (k \sin \phi)^2$

$$\begin{aligned} \approx \int_0^{\phi} (1-x)^{\frac{1}{2}} d\phi &= \int_0^{\phi} 1 - \frac{1}{2} \int_0^{\phi} (k \sin \theta)^2 d\theta - \frac{1}{8} \int_0^{\phi} (k^2 \sin^2 \theta)^2 d\theta - \dots \\ &= \phi - \frac{1}{2} k^2 \int_0^{\phi} \sin^2 \theta d\theta - \frac{k^4}{8} \int_0^{\phi} \sin^4 \theta d\theta - \dots \\ &= \phi - \frac{1}{2} k^2 \left[\frac{1}{2} \phi - \frac{1}{2} \cos \theta \sin \theta \right] - \frac{k^4}{8} \left[\frac{1}{4} (\phi - 2 \cos \theta \sin \theta + \frac{1}{2} \phi + \cos \theta \sin \theta) \right] \\ &= \phi - \frac{1}{4} k^2 \phi + \frac{k^2}{4} \cos \phi \sin \phi - \frac{k^4}{32} \left(\frac{3}{2} \phi - \cos \phi \sin \phi \right) \end{aligned}$$

→

$$E(k, \phi) = \phi - \frac{1}{4}k^2\phi + \frac{k^2}{4} \cos\phi \sin\phi - \frac{3}{64}k^4\phi + \frac{k^4}{32} \cos\phi \sin\phi \dots$$

Verify: try with $k = .5$ and $\phi = \frac{\pi}{4}$.

from Table, $E(k, \phi) = \boxed{0.767196}$

From series:

$$= \frac{\pi}{4} - \frac{.5^2}{4} \frac{\pi}{4} + \frac{.5^2}{4} \cos \frac{\pi}{4} \sin \frac{\pi}{4} - \frac{3}{64} \cdot .5^4 \frac{\pi}{4} + \frac{.5^4}{32} \cos \frac{\pi}{4} \sin \frac{\pi}{4}$$

$$= \boxed{\cancel{0.767196}} \quad \boxed{0.766236}$$

This is a very good approximation with only 3 terms.
error is only 0.1%.

this tells me that $F(k, \phi)$ does not converge as quickly as $E(k, \phi)$ (unless I made a mistake).

Now use these series to find ^{series for} complete elliptic integrals

K and E :

$K = F(k, \frac{\pi}{2})$, so replace ϕ with $\frac{\pi}{2}$ in the series for $F(\cdot)$ found.

$$= \frac{\pi}{2} + \frac{k^2}{4} \frac{\pi}{2} - \frac{k^2}{4} \cos \frac{\pi}{2} \sin \frac{\pi}{2} + \frac{9}{64} k^4 \frac{\pi}{2} - \frac{3}{32} k^4 \cos \frac{\pi}{2} \sin \frac{\pi}{2}$$

$$\boxed{K = \frac{\pi}{2} + \frac{k^2}{8} \pi + \frac{9}{128} k^4 \pi + \dots} \quad (\text{since } \cos \frac{\pi}{2} = 0 \text{ all Trig term disappears})$$

Similarly Find $E \longrightarrow$

$$E(k, \frac{\pi}{2}) = \frac{\pi}{2} - \frac{1}{4} k^2 \frac{\pi}{2} - \frac{k^2}{4} \cos \frac{\pi}{2} \sin \frac{\pi}{2} - \frac{3}{64} k^4 \frac{\pi}{2} + \frac{k^4}{32} \cos \frac{\pi}{2} \sin \frac{\pi}{2} \quad (13)$$

$$E(k) = \frac{\pi}{2} - \frac{k^2}{8} \pi - \frac{3k^4}{124} \pi - \dots$$

12.2 Find from Tables or (for small k) from power series of problem 1

$$K(0.13) = F(0.13, \frac{\pi}{2})$$

↓
lower case k

From Tables, (in Abramowitz), Page 608,

$$\text{for } m = k^2 = 0.13^2 = 0.0169, \text{ ~~use } k~~$$

$$\text{Table shows } K(0.01) = \text{~~1.57474~~} 1.57474$$

$$\text{and } K(0.02) = \text{~~1.57873~~} 1.57873$$

(What is best way to find values for K between entries in Table? use interpolation?).

$$\text{Take } K(0.13) = \text{~~1.57474~~} 1.58$$

From Table used 0.02 is closer!

using Series:

$$K = \frac{\pi}{2} + \frac{k^2}{8} \pi + \frac{9}{124} k^4 \pi$$

when $k = 0.13$, I get

$$K = 1.5775$$

From my series using only 3 terms.

(14)

Ch 11
12.7

$$\int_0^{\pi/4} \frac{d\phi}{\sqrt{1 - 0.25 \sin^2 \phi}}$$

here $k^2 = 0.25 \Rightarrow k = 0.5$ ✓

so use ~~$F(k, \phi)$~~ $F(0.5, \pi/4)$

From series expansion of the Legendre form of elliptic integral F :

$$F(k, \phi) = \phi + \frac{k^2}{4} \phi - \frac{k^2}{4} \cos \phi \sin \phi + \frac{9}{64} k^4 \phi - \frac{3}{32} k^4 \cos \phi \sin \phi$$

$$= \frac{\pi}{4} + \frac{.5^2}{4} \frac{\pi}{4} - \frac{.5^2}{4} \cos \frac{\pi}{4} \sin \frac{\pi}{4} + \frac{9}{64} .5^4 \frac{\pi}{4} - \frac{3}{32} .5^4 \cos \frac{\pi}{4} \sin \frac{\pi}{4}$$

$$= 0.807209$$
 ✓

From Mathematica I get 0.804366

12.9 ?

ch 11

12.16

Find the length of one arch of $y = \sin x$

15

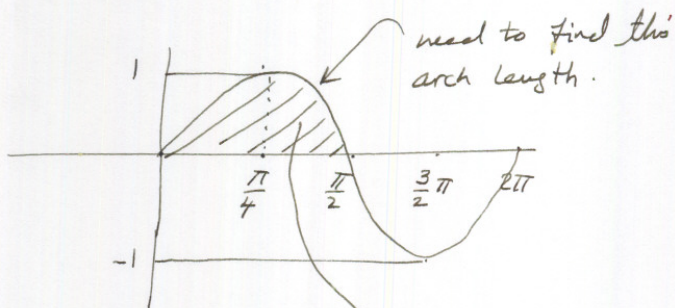

looking at the arch, after rotating it sideways by 90° , it becomes an ellipse as

so now I can use

E function to find length of arc for 0 to $\frac{\pi}{2}$, then arch length will be twice that.

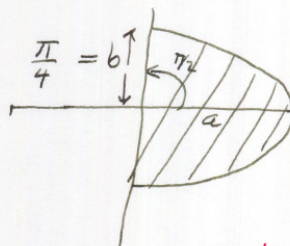

I don't understand your method!

$$\text{Arclength} = \int \sqrt{1 + \cos^2 t} dt$$

$$\left(\int \sqrt{1 + \left(\frac{dy}{dx}\right)^2} dx \right)$$

$$\text{ie } \boxed{\text{arch length} = 2 a E\left(k, \frac{\pi}{2}\right)}$$

must use $a > b$, here $a = 1$ (which is max value for \sin).

$$\text{so since } k^2 = \frac{a^2 - b^2}{a^2} = \frac{1 - \left(\frac{\pi}{4}\right)^2}{1} = 0.38315 \quad \frac{1}{5}$$

$$\text{so } \boxed{k = 0.618991}$$

$$\text{so arch length} = 2 E\left(0.618991, \frac{\pi}{2}\right)$$

$$= 2 (1.4)$$

$$= \boxed{2.8}$$

here E was obtained from mathematical tables.

Please note: book gives answer as 3.8. I went over this few times and don't see where I am making an error?

ch 11

15

12.18 sketch graph of $\text{sn}(u)$ as a function of u for $K = \frac{1}{2}$. Use table for the elliptic integral

$$u = \int_0^{\phi} \frac{d\phi}{\sqrt{1 - K^2 \sin^2 \phi}}$$

and remember that $\text{sn}(u) = \sin \phi$.

I generate this Table (use $K = 1/2$)

ϕ	$u = \int_0^{\phi} \frac{d\phi}{\sqrt{1 - K^2 \sin^2 \phi}} = F(K, \phi)$	$\text{sn}(u) = \sin \phi$
0	0	0
$\frac{\pi}{8}$	$F(\frac{1}{2}, \frac{\pi}{8}) = 0.395$	0.382
$\frac{\pi}{4}$	$F(\frac{1}{2}, \frac{\pi}{4}) = 0.804$	0.707
$\frac{3}{8}\pi$	$F(\frac{1}{2}, \frac{3}{8}\pi) = \cancel{1.235} 1.235$	0.92
$\frac{\pi}{2}$	$F(\frac{1}{2}, \frac{\pi}{2}) = 1.685$	1
$\frac{5}{8}\pi$	$F(\frac{1}{2}, \frac{5}{8}\pi) = 2.13$	0.92
$\frac{3}{4}\pi$	$F(\frac{1}{2}, \frac{3}{4}\pi) = 2.56$	0.707
$\frac{7}{8}\pi$	$F(\frac{1}{2}, \frac{7}{8}\pi) = 2.97$	0.38
π	$F(\frac{1}{2}, \pi) = 3.37$	0
$\frac{3}{2}\pi$	$F(\frac{1}{2}, \frac{3}{2}\pi) = 5.05$	-1
2π	$F(\frac{1}{2}, 2\pi) = 6.74$	0

→ plot

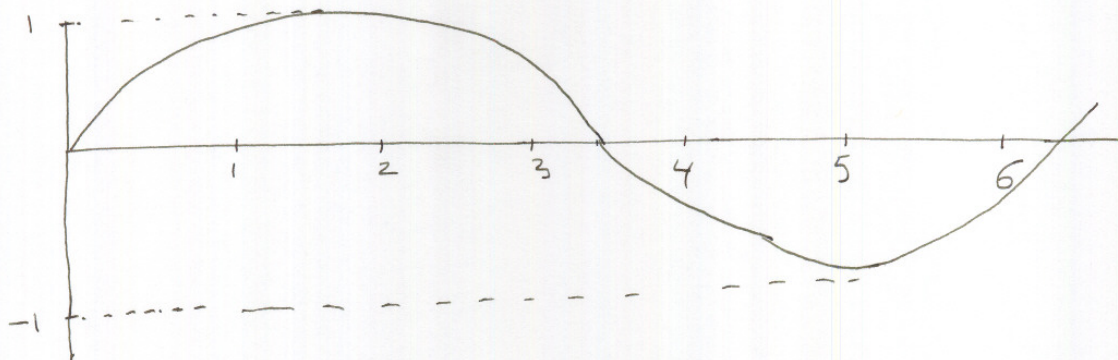

it looks very much like a ~~cos~~ sine function.

please see plot next page
using mathematica.

(18)

this is a plot of sn function using mathematica, along with the sin function to compare the two.

```
Plot[{JacobiSN[x, .52], Sin[x]}, {x, 0, 2 Pi},  
PlotStyle -> {Dashing [{0.05, 0.05}], Dashing [{0.01, 0.01}]}
```

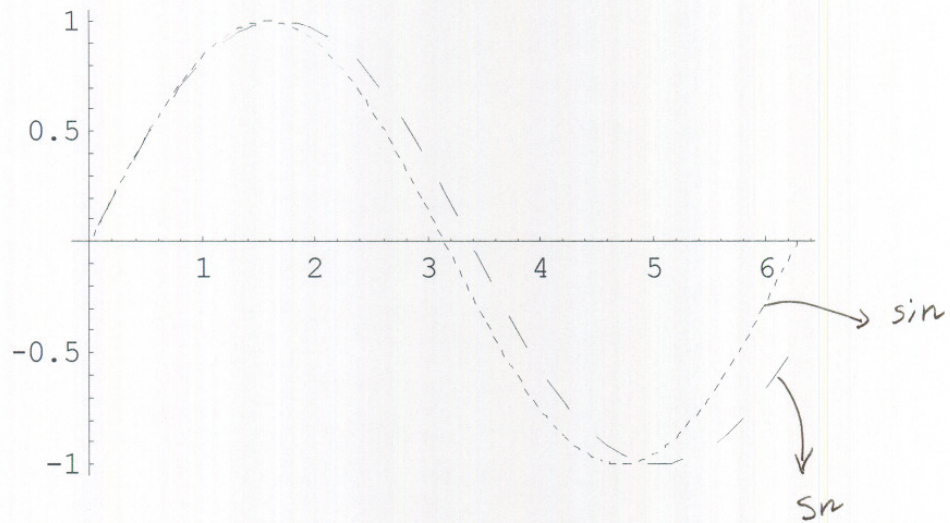

Ch 11

12.21

by transforming $\int_0^{\pi/2} \frac{d\phi}{\sqrt{\cos\phi}}$ to one of the standard

forms for an elliptic integral of first kind, show that

Beta function \leftarrow $B\left(\frac{1}{4}, \frac{1}{2}\right) = 2\sqrt{2} F\left(\frac{1}{\sqrt{2}}, \frac{\pi}{2}\right) = 2\sqrt{2} K\left(\frac{1}{\sqrt{2}}\right)$ and

so $K\left(\frac{1}{\sqrt{2}}\right) = \frac{1}{4\sqrt{\pi}} \Gamma^2\left(\frac{1}{4}\right)$.

Evaluate these expressions from tables to check result.

The First kind is either the Legendre form $\int_0^{\phi} \frac{d\phi}{\sqrt{1-k^2\sin^2\phi}}$ or the

Jacobi form $\int_0^x \frac{dx}{\sqrt{(1-x^2)(1-k^2x^2)}}$.

I will use the Legendre form.

let $\phi = 2\alpha \Rightarrow d\phi = 2d\alpha$

then $\int_0^{\pi/2} \frac{d\phi}{\sqrt{\cos\phi}} = \int_0^{\pi/4} \frac{2d\alpha}{\sqrt{\cos 2\alpha}}$

now since $\sin^2\alpha = \frac{1-\cos 2\alpha}{2}$ then $\cos 2\alpha = 1-2\sin^2\alpha$

so integral becomes $2 \int_0^{\pi/4} \frac{d\alpha}{\sqrt{1-2\sin^2\alpha}}$

this is in the form needed, however $K^2=2$ here, i.e. $K=\sqrt{2}$ which is irrational and also K is supposed to be $(0,1)$ range,

since $K^2 = \frac{a^2-b^2}{a^2}$, and in ellips $a > b$. Still, not

knowing what else to do, I used above form, and evaluated \rightarrow

$$2 \int_0^{\pi/4} \frac{d\alpha}{\sqrt{1-25\sin^2\alpha}} = 2 F(\sqrt{2}, \frac{\pi}{4})$$

$$= 2 \left(1.31 - 1.8 \times 10^{-16} i \right)$$

complex value
obtained from Mathematica

Since complex part is so small, I drop it.

so integral is $2(1.31) = \boxed{2.622}$

But if I keep the complex part I get

$$\boxed{2.622 - 3.7 \times 10^{-16} i}$$

4.3 HW 3

39/
40

HW # 3

Math 121 B

NASSER ABBASI

UCB extension.

Ch 12

1.1

solve DE using power series and by elementary method. Verify same solution.

$$y'' + 4y = 0$$

$$\text{let } y = a_0 + a_1 x + a_2 x^2 + a_3 x^3 + a_4 x^4 + \dots$$

$$y' = a_1 + 2a_2 x + 3a_3 x^2 + 4a_4 x^3 + \dots$$

$$y'' = 2a_2 + 2 \cdot 3 a_3 x + 3 \cdot 4 a_4 x^2 + \dots + (n)(n+2) a_{n+2} x^n$$

$$4y = 4a_0 + 4a_1 x + 4a_2 x^2 + 4a_3 x^3 + \dots + 4a_n x^n$$

$$\text{so } \boxed{(n+1)(n+2) a_{n+2} = -4 a_n}$$

now I can generate few a 's to see pattern for even and odd a 's.

$$n=0$$

$$1 \cdot 2 a_2 = -4 a_0 \Rightarrow a_2 = \frac{-4}{1 \cdot 2} a_0$$

$$n=1$$

$$2 \cdot 3 a_3 = -4 a_1 \Rightarrow a_3 = \frac{-4}{2 \cdot 3} a_1$$

$$n=2$$

$$3 \cdot 4 a_4 = -4 a_2 \Rightarrow a_4 = \frac{-4}{3 \cdot 4} a_2 = \frac{-4}{3 \cdot 4} \left(\frac{-4}{1 \cdot 2} \right) a_0 = \frac{+4^2}{1 \cdot 2 \cdot 3 \cdot 4} a_0$$

$$n=3$$

$$4 \cdot 5 a_5 = -4 a_3 \Rightarrow a_5 = \frac{-4}{4 \cdot 5} a_3 = \frac{-4}{4 \cdot 5} \left(\frac{-4}{2 \cdot 3} \right) a_1 = \frac{4^2}{2 \cdot 3 \cdot 4 \cdot 5} a_1$$

$$n=4$$

$$5 \cdot 6 a_6 = -4 a_4 \Rightarrow a_6 = \frac{-4}{5 \cdot 6} a_4 = \frac{-4}{5 \cdot 6} \frac{4^2}{1 \cdot 2 \cdot 3 \cdot 4} a_0 = \frac{-4^3}{1 \cdot 2 \cdot 3 \cdot 4 \cdot 5 \cdot 6} a_0$$

$$n=5$$

$$6 \cdot 7 a_7 = -4 a_5 \Rightarrow a_7 = \frac{-4}{6 \cdot 7} a_5 = \frac{-4}{6 \cdot 7} \frac{4^2}{2 \cdot 3 \cdot 4 \cdot 5} a_1 = \frac{-4^3}{2 \cdot 3 \cdot 4 \cdot 5 \cdot 6 \cdot 7} a_1$$

from this I see that for odd n , $a_n = \frac{4^{(n-1)/2}}{n!} a_1$

and for even n , $a_n = \frac{4^{n/2}}{n!} a_0$



so $y = a_0 \sum_{\substack{n \text{ even} \\ n \geq 0}} s(n) \frac{4^{n/2}}{n!} x^n + a_1 \sum_{\substack{n \text{ odd} \\ n \geq 1}} c(n) \frac{4^{(n-1)/2}}{n!} x^n$

this function flips the sign.
 $n=0$ it is +
 at $n=2$ it is -
 $n=4$ it is +
 $n=6$ it is -
 :
 etc

this flips the sign
 $n=1$ it is +
 at $n=3$ it is -
 $n=5$ it is +
 $n=7$ it is -
 :
 etc.

not sure how to write this in the sum directly.

looking at few terms in y we see

$$y = a_0 \left[1 - \frac{4}{2} x^2 + \frac{4^2}{4!} x^4 - \frac{4^3}{6!} x^6 + \dots \right]$$

\downarrow \downarrow \downarrow \downarrow
 $n=0$ $n=2$ $n=4$ $n=6$

This is power series of $\cos 2x$
 can be better seen by noting that $4=2^2$

$$+ a_1 \left[x - \frac{4}{3!} x^3 + \frac{4^2}{5!} x^5 - \dots \right]$$

\downarrow \downarrow \downarrow
 $n=1$ $n=3$ $n=5$

let $a_1 = 2C$ where C is some constant. I need to do this to make second series a sin series.

$$so \ y = a_0 [\cos 2x] + C \left[2x - \frac{2^3}{3!} x^3 + \frac{2^5}{5!} x^5 - \dots \right]$$

$$\boxed{y = a_0 \cos 2x + C \sin 2x}$$

③

now I solve using basic method to verify the series solution.

$$y'' + 4y = 0$$

$$\text{let } y = Ae^{mx}$$

$$y' = Ame^{mx}$$

$$y'' = Am^2e^{mx}$$

$$\text{so } Am^2e^{mx} + 4Ae^{mx} = 0$$

$$\text{i.e. } e^{mx}(Am^2 + 4A) = 0 \Rightarrow m^2 + 4 = 0 \Rightarrow m = \pm 2i$$

$$\text{so } y_1 = A_1 e^{2ix}, \quad y_2 = A_2 e^{-2ix}$$

$$\text{so general solution} = y_1 + y_2 = A_1 e^{2ix} + A_2 e^{-2ix}$$

$$= A_1 (\cos 2x + i \sin 2x) + A_2 (\cos -2x + i \sin -2x)$$

$$\text{but } \begin{aligned} \cos -x &= \cos x \\ \sin -x &= -\sin x \end{aligned}$$

$$\text{so } y = A_1 (\cos 2x + i \sin 2x) + A_2 (\cos 2x - i \sin 2x)$$

$$= \cos 2x (A_1 + A_2) + \sin 2x (A_1 - A_2) i$$

$$\text{let } A_1 + A_2 = C_1$$

$$\text{let } i(A_1 - A_2) = C_2$$

$$\text{so } \boxed{y = C_1 \cos 2x + C_2 \sin 2x}$$

which match series solution, where $C_1 = a_0$

$$\text{and } \frac{a_1}{2} = C_2$$

(4)

Ch 12

1.11

Solve by series method

$$y'' - x^2 y' - xy = 0$$

$$y = a_0 + a_1 x + a_2 x^2 + a_3 x^3 + a_4 x^4 + \dots$$

$$y' = a_1 + 2a_2 x + 3a_3 x^2 + 4a_4 x^3 + \dots$$

$$y'' = 2a_2 + 2 \cdot 3 a_3 x + 3 \cdot 4 a_4 x^2 + \dots + (n+1)(n+2) a_{n+2} x^n + \dots$$

$$xy = a_0 x + a_1 x^2 + a_2 x^3 + \dots + a_{n-1} x^n$$

$$x^2 y' = a_1 x^2 + 2a_2 x^3 + \dots + (n-1) a_{n-1} x^n$$

So recursive formula is

$$(n+1)(n+2) a_{n+2} x^n - (n-1) a_{n-1} x^n - a_{n-1} x^n = 0$$

$$\Rightarrow (n+1)(n+2) a_{n+2} - (n-1) a_{n-1} - a_{n-1} = 0$$

n=1:

$$2 \cdot 3 a_3 - a_0 = 0 \Rightarrow a_3 = \frac{1}{2 \cdot 3} a_0$$

n=2

$$3 \cdot 4 a_4 - a_1 - a_1 = 0 \Rightarrow a_4 = \frac{1}{3 \cdot 4} (a_1 + a_1) = \frac{2}{3 \cdot 4} a_1$$

n=3

$$4 \cdot 5 a_5 - 2a_2 - a_2 = 0 \Rightarrow a_5 = \frac{1}{4 \cdot 5} (2a_2 + a_2) = \frac{3}{4 \cdot 5} a_2$$

n=4

$$5 \cdot 6 a_6 - 3a_3 - a_3 = 0 \Rightarrow a_6 = \frac{4}{5 \cdot 6} a_3 = \frac{4}{5 \cdot 6} \cdot \frac{1}{2 \cdot 3} a_0 = \frac{4}{2 \cdot 3 \cdot 5 \cdot 6} a_0$$

n=5

$$6 \cdot 7 a_7 - 4a_4 - a_4 = 0 \Rightarrow a_7 = \frac{5}{6 \cdot 7} a_4 = \frac{5}{6 \cdot 7} \cdot \frac{2}{3 \cdot 4} a_1$$

n=6

$$7 \cdot 8 a_8 - 5a_5 - a_5 = 0 \Rightarrow a_8 = \frac{6}{7 \cdot 8} a_5 = \frac{6}{7 \cdot 8} \cdot \frac{3}{4 \cdot 5} a_2$$



now note that $a_2 = 0$ ✓ (by looking at Table of Coefficients.)

$$\text{so } a_3 = \frac{1}{2 \cdot 3} a_0$$

$$a_4 = \frac{2}{3 \cdot 4} a_1$$

$$a_5 = 0$$

$$a_6 = \frac{4}{2 \cdot 3 \cdot 5 \cdot 6} a_0$$

$$a_7 = \frac{5 \cdot 2}{6 \cdot 7 \cdot 3 \cdot 4} a_1$$

$$a_8 = 0$$

⋮

so, plug in y , we get

$$y = a_0 + a_1 x + \left(\frac{1}{2 \cdot 3} a_0\right) x^3 + \left(\frac{2}{3 \cdot 4}\right) a_1 x^4 + \frac{4}{2 \cdot 3 \cdot 5 \cdot 6} a_0 x^6 + \frac{5 \cdot 2}{6 \cdot 7 \cdot 3 \cdot 4} a_1 x^7$$

$$y = a_0 \left[1 + \frac{1}{2 \cdot 3} x^3 + \frac{4}{2 \cdot 3 \cdot 5 \cdot 6} x^6 + \dots \right]$$

$$+ a_1 \left[x + \frac{2}{3 \cdot 4} x^4 + \frac{5 \cdot 2}{6 \cdot 7 \cdot 3 \cdot 4} x^7 + \dots \right]$$

To make denominators factorial expressions, I multiply numerator and denominator for each term as needed:

$$y = a_0 \left[1 + \frac{x^3}{3!} + \frac{(4)(4)}{2 \cdot 3 \cdot 4 \cdot 5 \cdot 6} x^6 + \dots \right]$$

$$+ a_1 \left[x + \frac{2(2)}{2 \cdot 3 \cdot 4} x^4 + \frac{5(5)}{2 \cdot 3 \cdot 4} \frac{2(4)}{5 \cdot 6 \cdot 7} x^7 + \dots \right]$$

$$\boxed{y = a_0 \left[1 + \frac{x^3}{3!} + \frac{4^2}{6!} x^6 + \dots \right] + a_1 \left[x + \frac{2^2}{4!} x^4 + \frac{(5 \cdot 2)^2}{7!} x^7 + \dots \right]}$$

✓ this is the Series Solution.

ch 12
1.16

solve $(x^2+1)y'' - 2xy' + 2y = 0$ by series method.

$$y = a_0 + a_1 x + a_2 x^2 + a_3 x^3 + a_4 x^4 + \dots$$

$$y' = a_1 + 2a_2 x + 3a_3 x^2 + 4a_4 x^3 + \dots$$

$$y'' = 2a_2 + 6a_3 x + 12a_4 x^2 + \dots$$

$$2y = 2a_0 + 2a_1 x + 2a_2 x^2 + 2a_3 x^3 + \dots$$

$$2xy' = 2a_1 x + 4a_2 x^2 + 6a_3 x^3 + \dots$$

$$x^2 y'' = 2a_2 x^2 + 6a_3 x^3 + 12a_4 x^4 + \dots$$

by inspection, looking at first column, $2a_2 + 2a_0 = 0$ i.e. $a_2 = -a_0$

now I write the general recursive formula for x^n

$$\underbrace{x^2 y''}_{n(n-1)a_n x^n} + \underbrace{y''}_{(n+1)(n+2)a_{n+2} x^n} - \underbrace{2xy'}_{2n a_n x^n} + \underbrace{2y}_{2a_n x^n} \rightarrow$$

D.E.
since equation equals zero, then coeff. of each power of x must be zero as well. hence

$$(n(n-1)a_n + (n+1)(n+2)a_{n+2} - 2n a_n + 2a_n) x^n = 0$$

i.e.

$$(n+1)(n+2)a_{n+2} = -n(n-1)a_n - 2a_n + 2a_n$$

$$(n+1)(n+2)a_{n+2} = a_n (2n-2 - n(n-1))$$

I will now use this to generate few 'a' terms \rightarrow

let me simplify the recursive equation a little more

$$(n+1)(n+2) a_{n+2} = a_n (3n - n^2 - 2)$$

~~start~~

start with $n=1$ since I already know a_2 .

$n=1$

$$(2)(3) a_3 = a_1 (3 - 1 - 2) \Rightarrow a_3 = 0$$

$n=2$

$$(3)(4) a_4 = a_2 (6 - 4 - 2) \Rightarrow a_4 = 0$$

$n=3$

$$(4)(5) a_5 = a_3 (9 - 9 - 2) \Rightarrow a_5 = 0$$

actually, no need to continue:

since, $a_3 = 0$ and $a_4 = 0$, and this recursive relation

finds a_{n+2} in terms of a_n , then all a_n are

Zero for $n=3, 4, 5, \dots$!

$$\text{so } y = a_0 + a_1 x + a_2 x^2$$

$$= a_0 + a_1 x - a_0 x^2$$

$$y = a_0 [1 - x^2] + a_1 x$$

ch 12

$$\boxed{2.1} \text{ using 2.6: } a_{n+2} = - \frac{(l-n)(l+n+1)}{(n+2)(n+1)} a_n \text{ and}$$

$$2.7: y = a_0 \left[1 - \frac{l(l+1)}{2!} x^2 + \frac{l(l+1)(l-2)(l+3)}{4!} x^4 - \dots \right] \\ + a_1 \left[x - \frac{(l-1)(l+2)}{3!} x^3 + \frac{(l-1)(l+2)(l-3)(l+4)}{5!} x^5 - \dots \right]$$

and the requirement that $P_l(1) = 1$, find $P_2(x)$, $P_3(x)$ and $P_4(x)$.

Solution

If I write $y = a_0$

$$y = a_0 \left(1 + a_2 x^2 + a_4 x^4 + a_6 x^6 + \dots \right) \leftarrow \text{The even } l \text{ series} \\ + a_1 \left(x + a_3 x^3 + a_5 x^5 + \dots \right) \rightarrow \text{The odd } l \text{ series.}$$

The ' a_0 ' series is the one that remains for $l = 0, 2, 4, 6, 8, \dots$ and the ' a_1 ' series diverges in those cases and not used.

the ' a_1 ' series remains for $l = 1, 3, 5, 7, \dots$ and the ' a_0 ' series diverges for those values and not used.

so for $P_2(x)$, this is $l=2$. hence will use the a_0 series.

for $P_3(x)$, this is $l=3$, hence use the a_1 series

for $P_4(x)$, this is $l=4$, hence use the a_0 series.

$$\text{so } P_2(x) = a_0 (1 + a_2 x^2)$$

$$P_3(x) = a_1 (x + a_3 x^3)$$

$$P_4(x) = a_0 (1 + a_2 x^2 + a_4 x^4)$$

so I just need to find the a 's above to complete the solution \Rightarrow

$$\begin{aligned} \text{for } l=2, \quad a_2 &= - \frac{(l-0)(l+0+1)}{(0+2)(0+1)} a_0 \\ & \quad \downarrow \\ & \quad \text{ie } n=0 \\ &= - \frac{(2)(2+1)}{2} a_0 = - \frac{(2)(3)}{2} a_0 = -\frac{3}{1} a_0. \end{aligned} \quad (7)$$

hence $P_2(x) = a_0(1-3x^2)$

a_0 is found by using the restriction that y must be 1 when $x=1$.

$$\text{so } 1 = a_0(1-3(1)^2) = a_0(1-3)$$

$$\text{so } a_0 = -\frac{1}{2}$$

$$\text{so } P_2(x) = -\frac{1}{2}(1-3x^2) = \boxed{\frac{1}{2}(3x^2-1)}$$

for $l=3$.

$$P_3(x) = a_4(x + a_3x^3)$$

$$a_3 \equiv a_{n+2} \quad \text{so } n=1$$

$$\text{so } a_3 = - \frac{(l-1)(l+1+1)}{(1+2)(1+1)} a_1 = - \frac{(l-1)(l+2)}{3 \cdot 2} a_1$$

$$\text{let } l=3, \quad a_3 = - \frac{(3-1)(3+2)}{3 \cdot 2} a_1 = - \frac{(2)(5)}{3 \cdot 2} a_1 = -\frac{5}{3} a_1$$

so $P_3(x) = a_1(x - \frac{5}{3}x^3)$. apply the boundary restriction:

$$1 = a_1(1 - \frac{5}{3}) \Rightarrow 1 = a_1(\frac{-2}{3}) \Rightarrow a_1 = -\frac{3}{2}$$

$$\text{so } P_3(x) = -\frac{3}{2}(x - \frac{5}{3}x^3) = \frac{5}{2}x^3 - \frac{3}{2}x = \boxed{\frac{1}{2}(5x^3 - 3x)}$$

\Rightarrow

for $l=4$

$$P_4(x) = a_0(1 + a_2 x^2 + a_4 x^4)$$

find a_2 , and use to find a_4 .

$$a_2, \text{ i.e. } n=0 \Rightarrow a_2 = - \frac{(l-0)(l+0+1)}{(0+2)(0+1)} a_0$$

$$= - \frac{l(l+1)}{2} a_0 \cdot \xrightarrow{l=4} - \frac{4(5)}{2} a_0 = -10 a_0$$

$$a_4, \text{ i.e. } n=2 \Rightarrow a_4 = - \frac{(l-2)(l+2+1)}{(2+2)(2+1)} a_2$$

$$\xrightarrow{l=4} a_4 = - \frac{(4-2)(4+2+1)}{(4)(3)} a_2 = - \frac{(2)(7)}{(4)(3)} \overbrace{(-10 a_0)}^{a_2}$$

$$a_4 = + \frac{70}{6} a_0 = + \frac{35}{3} a_0$$

$$\text{so } P_4(x) = a_0 \left(1 - 10x^2 + \frac{35}{3}x^4 \right)$$

now apply boundary conditions to find a_0

$$1 = a_0 \left(1 - 10 + \frac{35}{3} \right) \Rightarrow 1 = a_0 \left(\frac{3-30+35}{3} \right) = a_0 \left(\frac{8}{3} \right)$$

$$\text{so } a_0 = \frac{3}{8}$$

$$\text{so } P_4(x) = \frac{3}{8} \left(1 - 10x^2 + \frac{35}{3}x^4 \right) = \frac{3}{8} - \frac{30x^2}{8} + \frac{35}{8}x^4$$

$$P_4(x) = \frac{1}{8} (35x^4 - 30x^2 + 3)$$

ch 12
2.2

show that $P_l(-1) = (-1)^l$

(9)

$$P_l(x) = a_0 \underbrace{[1 + a_2 x^2 + a_4 x^4 + \dots]}_{\text{sum of even functions in } x} + a_1 \underbrace{[x + a_3 x^3 + \dots]}_{\text{sum of odd functions in } x}$$

There are 2 cases to consider. when l is even, and odd.

when l is even

then $P_l(x)$ is the sum of even functions (x^2, x^4, x^6, \dots)
but sum of even functions is an even function.

$$\text{so } P_l(-x) = P_l(x)$$

$$\text{for } x=1, \text{ we set } P_l(-1) = P_l(1)$$

but $P_l(1) = 1$ by definition, since this is the boundary condition; we want to solve for.

$$\text{so } P_l(-1) = 1$$

now since l is even,

$$\text{then } 1 = (-1)^l$$

$$\begin{aligned} l &= -1^0 \\ &= -1^2 \\ &= -1^4 \\ &= -1^6 \\ &\vdots \end{aligned}$$

$$\text{so } \boxed{P_l(-1) = (-1)^l} \quad (1)$$

now for the case l is odd:

now $P_l(x)$ is sum of odd functions of x , (x, x^3, x^5, \dots)

so $P_l(x)$ is an odd function.

$$\text{i.e. } P_l(-x) = -P_l(x)$$

$$\text{for } x=1, \text{ we have } P_l(-1) = -P_l(1) = -1$$

again, since l is odd, then -1 is the same as $(-1)^l$

$$\text{hence } \boxed{P_l(-1) = (-1)^l} \quad (2) \quad \text{from (1) \& (2), then } \boxed{P_l(-1) = (-1)^l \text{ for all } l}$$

Ch 12

(10)

2.3 sketch graph of $P_0(x)$, $P_1(x)$, $P_2(x)$, $P_3(x)$ from $x = -1$ to $x = 1$.

in all graphs we must have $P_l(1) = 1$ since this is the boundary condition on the solution of the D.E. we used to obtain the Legendre polynomials.

in addition $P_l(0) = 0$ for odd l .

also, $P_l(-1) = (-1)^l$, so $P_l(-1) = 1$ for even l , and $P_l(-1) = -1$ for odd l .

$P_0(x) = 1$, plot is

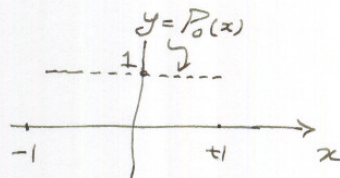

$P_1(x) = x$, plot is

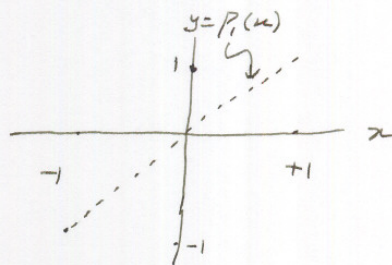

$P_2(x) = \frac{1}{2}(3x^2 - 1)$

when $y = 0 \Rightarrow 3x^2 - 1 = 0$ i.e. $x = \pm \sqrt{\frac{1}{3}}$ are the roots.

when $x = 0 \Rightarrow P_2(x) = -\frac{1}{2}$ so plot

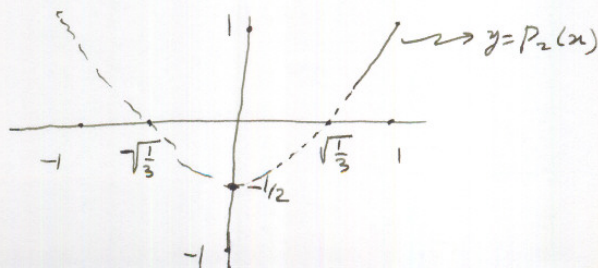

(11)

$$P_3(x) = \frac{1}{2}(5x^3 - 3x)$$

when $y=0 \Rightarrow 5x^3 - 3x = 0 \quad \text{or} \quad x(5x^2 - 3) = 0.$

i.e. $x=0$ or $5x^2 - 3 = 0$ i.e. $x^2 = \frac{3}{5}$ or $x = \pm \sqrt{\frac{3}{5}}$

so roots are $0, +\sqrt{\frac{3}{5}}, -\sqrt{\frac{3}{5}}$

so, in the plot we have

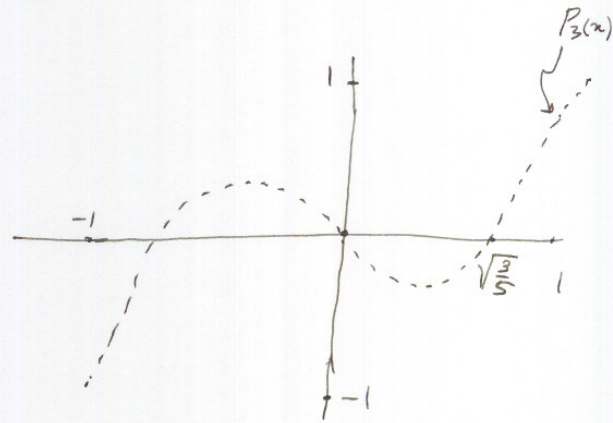

putting the ~~3~~ plots all on one diagram we have

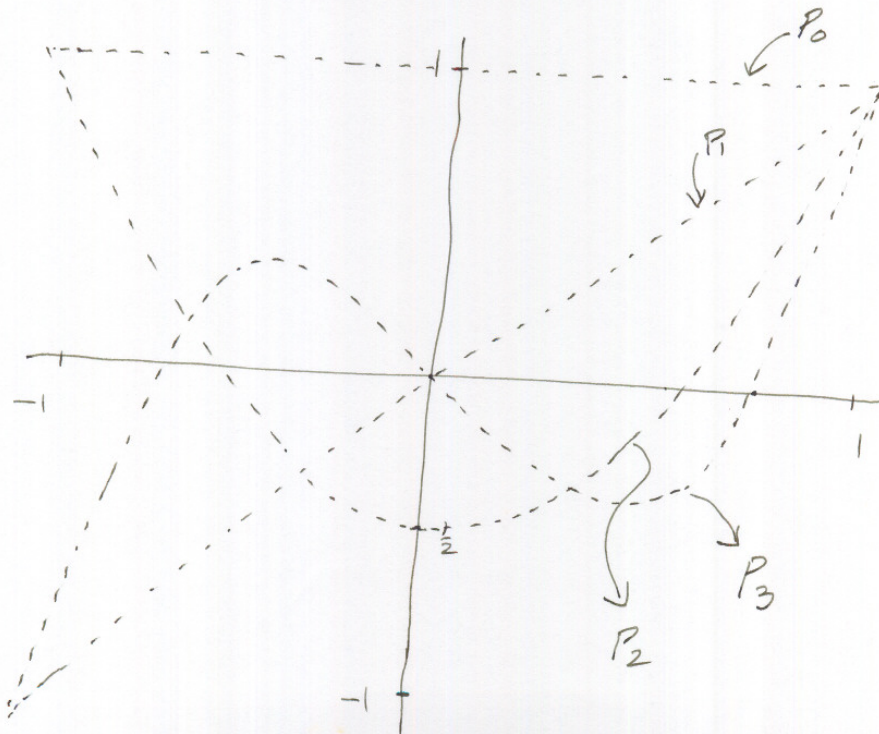

Ch 12

3.5

Solve $\frac{d^{100}}{dx^{100}} x^2 e^{-x}$ using Leibniz rule.

Leibniz rule is used for differentiation of products

it says
$$\frac{d^n}{dx^n} uv = \frac{d^0}{dx^0} u \frac{d^n}{dx^n} v + n \frac{d^1}{dx^1} u \frac{d^{n-1}}{dx^{n-1}} v$$

$$+ \frac{n(n-1)}{2!} \frac{d^2}{dx^2} u \frac{d^{n-2}}{dx^{n-2}} v + \dots$$

taking $u = x^2$ and $v = e^{-x}$, we get

$$\frac{d^{100}}{dx^{100}} x^2 e^{-x} = \frac{d^0}{dx^0} x^2 \frac{d^{100}}{dx^{100}} e^{-x} + 100 \frac{d^1}{dx^1} x^2 \frac{d^{99}}{dx^{99}} e^{-x} + \frac{(100)(99)}{2!} \frac{d^2}{dx^2} x^2 \frac{d^{98}}{dx^{98}} e^{-x} +$$

$$\frac{(100)(99)(98)}{3!} \frac{d^3}{dx^3} x^2 \frac{d^{97}}{dx^{97}} e^{-x} + \dots$$

but $\frac{d^n}{dx^n} x^m = 0$ for $n > m$. so all terms from here and the rest are zero.

$$\text{So } \frac{d^{100}}{dx^{100}} x^2 e^{-x} = x^2 \frac{d^{100}}{dx^{100}} e^{-x} + 100(2x) \frac{d^{99}}{dx^{99}} e^{-x} + \frac{(100)(99)}{2} \frac{d^{98}}{dx^{98}} e^{-x}$$

now need to find $\frac{d^m}{dx^m} e^{-x}$. by trying few terms I see

$$\left. \begin{aligned} \frac{d}{dx} e^{-x} &= -e^{-x} \\ \frac{d^2}{dx^2} e^{-x} &= e^{-x} \\ \frac{d^3}{dx^3} e^{-x} &= -e^{-x} \end{aligned} \right\} \text{ so } \frac{d^m}{dx^m} e^{-x} = \begin{cases} -e^{-x} & \text{when } m \text{ is even} \\ e^{-x} & \text{when } m \text{ is odd.} \end{cases}$$

$$\text{hence Result} = x^2 (+e^{-x}) + 200x (e^{-x}) + 9900 (+e^{-x}) = \boxed{e^{-x}(9900 + x^2) + 200x e^{-x}}$$

(13)

Ch 12

4.3 Find $P_0(x)$, $P_1(x)$, $P_2(x)$, $P_3(x)$ and $P_4(x)$ from Rodrigues formula (4.1). Compare your solution with (2.8) and problem 2.1.

Rodrigues formula generates Legendre's polynomials for different l values and given by

$$P_l(x) = \frac{1}{2^l l!} \frac{d^l}{dx^l} (x^2-1)^l$$

$$P_0(x) = \frac{1}{2^0 0!} \frac{d^0}{dx^0} (x^2-1)^0 = \boxed{1}$$

$$P_1(x) = \frac{1}{2 \cdot 1!} \frac{d}{dx} (x^2-1)^1 = \frac{1}{2} (2x) = \boxed{x}$$

$$\begin{aligned} P_2(x) &= \frac{1}{2^2 2!} \frac{d^2}{dx^2} (x^2-1)^2 = \frac{1}{8} \frac{d}{dx} \left(\frac{d}{dx} (x^2-1)^2 \right) \\ &= \frac{1}{8} \frac{d}{dx} (2(x^2-1) \cdot 2x) = \frac{1}{8} \frac{d}{dx} (4x^3 - 4x) = \frac{1}{8} (12x^2 - 4) \\ &= \boxed{\frac{1}{2} (x^2-1)} \end{aligned}$$

$$\begin{aligned} P_3(x) &= \frac{1}{2^3 3!} \frac{d^3}{dx^3} (x^2-1)^3 = \frac{1}{8 \cdot 6} \frac{d^2}{dx^2} \left(\frac{d}{dx} (x^2-1)^3 \right) \\ &= \frac{1}{48} \frac{d^2}{dx^2} (3(x^2-1)^2 \cdot 2x) = \frac{1}{48} \frac{d^2}{dx^2} (6x(x^4 - 2x^2 + 1)) \\ &= \frac{1}{48} \frac{d^2}{dx^2} (6x^5 - 12x^3 + 6x) = \frac{1}{48} \frac{d}{dx} \left(\frac{d}{dx} (6x^5 - 12x^3 + 6x) \right) \\ &= \frac{1}{48} \frac{d}{dx} (28x^4 - 24x^2 + 6) = \frac{1}{48} (36x^3 - 24x) \\ &= \frac{1}{48} \frac{d}{dx} (30x^4 - 36x^2 + 6) = \frac{1}{48} (120x^3 - 72x) = \boxed{\frac{1}{2} (5x^3 - 3x)} \end{aligned}$$

→ back

(14)

$$\begin{aligned} \frac{d^2}{dx^2} (x^2-1)^3 &= \frac{d}{dx} \left(3(x^2-1)^2 \cdot 2x \right) = \frac{d}{dx} (6x^5 - 12x^3 + 6x) \\ &= 30x^4 - 36x^2 + 6 \end{aligned}$$

$$\frac{d^3}{dx^3} (x^2-1)^3 = \frac{d}{dx} \left(\begin{array}{c} \downarrow \\ \end{array} \right) = 120x^3 - 72x$$

$$\frac{d^4}{dx^4} (x^2-1)^3 = \frac{d}{dx} \left(\begin{array}{c} \downarrow \\ \end{array} \right) = \frac{360}{720} x^2 - 72$$

so now plug above into (1) we get:

$$\begin{aligned} &= (x^2-1)(360x^2-72) + 8x(120x^3-72x) + 12(30x^4-36x^2+6) \\ &= 144 - 1440x^2 + \cancel{720x^4} + \cancel{1320x^4} + 1680x^4 \end{aligned}$$

$$\begin{aligned} \text{so } P_4(x) &= \frac{1}{244!} \left(\begin{array}{c} \downarrow \\ \end{array} \right) \\ &= \frac{1}{384} \left(\begin{array}{c} \downarrow \\ \end{array} \right) \end{aligned}$$

$$\text{so } P_4(x) = \frac{1}{384} (1680x^4 - 1440x^2 + 144)$$

$$P_4(x) = \frac{1}{48} (35x^4 - 30x^2 + 3)$$

This result agrees with result obtained in 2.1

ch 12

4.4

show that $\int_{-1}^1 x^m P_l(x) dx = 0$ if $m < l$.

(15)

use Rodrigues formula, write $P_l(x) = \frac{1}{2^{l!}} \frac{d^l}{dx^l} (x^2-1)^l$

4/5

let $k = \frac{1}{2^{l!}}$ so $P_l(x) = k \frac{d^l}{dx^l} (x^2-1)^l$

hence integral is $k \int_{-1}^1 x^m \frac{d}{dx} \left(\frac{d^{l-1}}{dx^{l-1}} (x^2-1)^l \right) dx = k \int_{-1}^1 x^m d \left(\frac{d^{l-1}}{dx^{l-1}} (x^2-1)^l \right)$

apply integration by parts: $\int u dv = uv - \int v du$

$u = x^m \Rightarrow du = m x^{m-1}$

$dv = d \left(\frac{d^{l-1}}{dx^{l-1}} (x^2-1)^l \right) \Rightarrow v = \frac{d^{l-1}}{dx^{l-1}} (x^2-1)^l$

hence integral = $k \left[x^m \frac{d^{l-1}}{dx^{l-1}} (x^2-1)^l \right]_{-1}^1 - k m \int_{-1}^1 x^{m-1} \frac{d^{l-1}}{dx^{l-1}} (x^2-1)^l$

(1)

now I show that $\left[x^m \frac{d^{l-1}}{dx^{l-1}} (x^2-1)^l \right]_{-1}^1$ is zero.

looking at $\frac{d^{l-1}}{dx^{l-1}} (x^2-1)^l \Rightarrow$ look at $(x^2-1)^l$. write as $(x-1)^l (x+1)^l$

~~differentiate this we get $(2x-2)^l$~~
~~we can also get~~

so $\frac{d^{l-1}}{dx^{l-1}} (x^2-1)^l = \frac{d^{l-1}}{dx^{l-1}} (x-1)^l (x+1)^l$

apply Leibniz rule for differentiation of products. $\frac{d^n}{dx^n} ab = a \frac{d^n}{dx^n} b + n \frac{d}{dx} a \frac{d^{n-1}}{dx^{n-1}} b + \dots$

$= (x+1)^l \frac{d^{l-1}}{dx^{l-1}} (x-1)^l + (l-1) \frac{d}{dx} (x+1)^l \frac{d^{l-2}}{dx^{l-2}} (x-1)^l + \dots$

I'm not sure how the result follows... I think the idea is that $\frac{d^k}{dx^k} (x+1)^l \sim (x+1)^{l-k}$, which is zero when $x=-1$. Similar result for $\frac{d^k}{dx^k} (x-1)^l$

now $\frac{d^2}{dx^2} (x+1)^l = \frac{d}{dx} \left(\frac{d}{dx} (x+1)^l \right) = \frac{d}{dx} (l) = 0$

are left with

$\frac{d^{l-1}}{dx^{l-1}} (x^2-1)^l = (x+1)^l \frac{d^{l-1}}{dx^{l-1}} (x-1)^l + (l-1) \frac{d}{dx} (x+1)^l \frac{d^{l-2}}{dx^{l-2}} (x-1)^l$

hence in the above we are every term in the expansion above is a product of such terms, hence vanishes at both $x=1$ and $x=-1$.

now going back to equation (1), we have

(16)

$$\int_{-1}^1 x^m P_l(x) dx = k \left[x^m \frac{d^{l-1}}{dx^{l-1}} (x^2-1)^l \right]_{-1}^1 - km \int_{-1}^1 x^{m-1} \frac{d^{l-1}}{dx^{l-1}} (x^2-1)^l dx$$

this is zero as shown.

$$\text{so } \int_{-1}^1 x^m P_l(x) dx = -km \int_{-1}^1 x^{m-1} \frac{d^{l-1}}{dx^{l-1}} (x^2-1)^l dx$$

Now, apply integration by parts again to this

$$= -km \int_{-1}^1 x^{m-1} \frac{d}{dx} \left(\frac{d^{l-2}}{dx^{l-2}} (x^2-1)^l \right) dx = -km \int_{-1}^1 x^{m-1} d \left(\frac{d^{l-2}}{dx^{l-2}} (x^2-1)^l \right)$$

as before, we get the $[uv] - \int v du$, and as before, the $[uv]$ term reduced to zero.

hence each time we apply integration by parts, $x^m \rightarrow x^{m-1}$ and

$$\frac{d^k}{dx^k} (x^2-1)^l \rightarrow \frac{d^{k-1}}{dx^{k-1}} (x^2-1)^l$$

This is a race between m and l .

if $m < l$, then we can terminate integration by parts with $\int_{-1}^1 (\text{some constant}) \frac{d^n}{dx^n} (x^2-1)^l dx$

$$\text{but } \int_{-1}^1 \frac{d}{dx} \left(\frac{d^{n-1}}{dx^{n-1}} (x^2-1)^l \right) dx = \left[\frac{d^{n-1}}{dx^{n-1}} (x^2-1)^l \right]_{-1}^1$$

by the fundamental theory of calculus.

but the expression we have shown to be zero. hence this completes the proof.

$$\text{so } \int_{-1}^1 x^m P_l(x) dx = 0 \text{ if } m < l.$$

(17)

ch 12

5.1

Find $P_3(x)$ by setting one more term in the generating function expansion 5.3.

$$\phi(x, h) = \frac{1}{(1-2xh+h^2)^{1/2}} \quad |h| < 1 \quad (1)$$

$$\phi(x, h) = P_0(x) + h P_1(x) + h^2 P_2(x) + h^3 P_3(x) + \dots + h^l P_l(x) + \dots$$

expand (1) in power series. let $y = 2xh - h^2$, then (1) can be written as

$$\phi(y) = \phi(x, h) = (1-y)^{-1/2} \quad \text{expand } \phi(y) \text{ as Taylor series around } y=0$$

$$\phi(y) = (1-y)^{-1/2} \Rightarrow 1 \quad \text{at } y=0$$

$$\phi'(y) = -\frac{1}{2} (1-y)^{-3/2} (-1) \Rightarrow +\frac{1}{2} \quad \text{at } y=0$$

$$\phi''(y) = +\frac{1}{2} \left(-\frac{3}{2}\right) (1-y)^{-5/2} (-1) \Rightarrow +\frac{3}{2^2} \quad \text{at } y=0$$

$$\phi'''(y) = +\frac{1}{2} \left(+\frac{3}{2}\right) \left(-\frac{5}{2}\right) (1-y)^{-7/2} (-1) \Rightarrow +\frac{3 \cdot 5}{2^3} \quad \text{at } y=0$$

$$\text{so } \phi(y) = \phi(\bar{y}) + \phi'(\bar{y}) y + \frac{\phi''(\bar{y})}{2!} y^2 + \frac{\phi'''(\bar{y})}{3!} y^3 + \dots$$

$$= 1 + \left(+\frac{1}{2}\right) y + \frac{3}{4} \frac{1}{2!} y^2 + \left(+\frac{3 \cdot 5}{8}\right) \frac{1}{3!} y^3 + \dots$$

$$\phi(y) = 1 + \frac{1}{2} y + \frac{3}{8} y^2 + \frac{15}{48} y^3 + \dots$$

now replace y with $2xh - h^2$ we set

$$\phi(x, h) = 1 + \frac{1}{2} (2xh - h^2) + \frac{3}{8} (2xh - h^2)^2 + \frac{15}{48} (2xh - h^2)^3 + \dots$$

$$= 1 + xh - \frac{h^2}{2} + \frac{3}{8} (4x^2h^2 - 4xh^3 + h^4) + \frac{15}{48} ((2xh - h^2)^2 (2xh - h^2))$$

$$= 1 + xh - \frac{h^2}{2} + \frac{12}{8} x^2h^2 - \frac{3}{2} xh^3 + \frac{3}{8} h^4 + \frac{15}{48} ((4x^2h^2 - 4xh^3 + h^4) (2xh - h^2))$$

(19)

Ch 12

5.3

use recursion relation $l P_l(x) = (2l-1)x P_{l-1}(x) - (l-1)P_{l-2}(x)$ and the values P_0 and P_1 to find P_2, P_3, P_4, P_5, P_6 .

$$P_0 = 1$$

$$P_1 = x$$

so for P_2 , $l=2$. hence from the recursion formula

$$2P_2 = (4-1)x P_1 - P_0 = 3x(x) - 1 = 3x^2 - 1$$

$$\text{i.e. } P_2 = \boxed{\frac{1}{2}(3x^2 - 1)}$$

now set $l=3$

$$\text{so } 3P_3 = 5x P_2 - P_1 = 5x \left(\frac{1}{2}(3x^2 - 1) \right) - 2x$$

$$= 5x \left(\frac{3}{2}x^2 - \frac{1}{2} \right) - 2x = \frac{15x^3}{2} - \frac{5x}{2} - 2x = \frac{15x^3}{2} - \frac{(5+4)x}{2}$$

$$3P_3 = \frac{15x^3}{2} - \frac{9}{2}x = \frac{1}{2}(15x^3 - 9x)$$

$$\text{so } P_3 = \boxed{\frac{1}{2}(5x^3 - 3x)}$$

For P_4 , $l=4$.

$$\text{so } 4P_4 = 7x P_3 - 3P_2 = 7x \left(\frac{5}{2}x^3 - \frac{3}{2}x \right) - 3 \left(\frac{3x^2}{2} - \frac{1}{2} \right)$$

$$= \frac{35}{2}x^4 - \frac{21}{2}x^2 - \frac{9x^2}{2} + \frac{3}{2}$$

$$= \frac{35}{2}x^4 - \frac{30}{2}x^2 + \frac{3}{2}$$

$$\text{so } P_4 = \frac{35}{8}x^4 - \frac{30}{8}x^2 + \frac{3}{8}$$

$$= \boxed{\frac{1}{8}(35x^4 - 30x^2 + 3)}$$

→

(18)

$$\begin{aligned}
 &= 1 + xh + h^2 \left(-\frac{1}{2} + \frac{3}{2}x^2 \right) - \frac{3}{2}xh^3 + \frac{3}{8}h^4 + \frac{15}{48} \left(8x^3h^3 - 4x^2h^4 - 8x^2h^4 + 4xh^5 + 2xh^5 - h^6 \right) \\
 &= P_0 + hP_1 + h^2P_2 + h^3 \left(-\frac{3}{2}x + \frac{15}{48}x^3 \right) + h^4 \left(\dots \right) + \dots \\
 &= P_0 + hP_1 + h^2P_2 + h^3 \left(-\frac{3}{2}x + \frac{15}{6}x^3 \right) + \dots \\
 &= P_0 + hP_1 + h^2P_2 + h^3 \frac{1}{2} \left(\frac{15}{3}x^3 - 3x \right) + \dots \\
 &= P_0 + hP_1 + h^2P_2 + h^3 \underbrace{\frac{1}{2} (5x^3 - 3x)}_{\text{but this is } P_3(x)} + \dots
 \end{aligned}$$

do not care for P_3

hence
$$= P_0(x) + hP_1(x) + h^2P_2(x) + h^3P_3(x) + \dots$$

(20)

for P_5 , $l=5$

$$\begin{aligned} \text{so } 5P_5 &= 9xP_4 - 4P_3 \\ &= 9x \left(\frac{35}{8}x^4 - \frac{30}{8}x^2 + \frac{3}{8} \right) - 4 \left(\frac{5}{2}x^3 - \frac{3}{2}x \right) \\ &= \frac{315x^5}{8} - \frac{270x^3}{8} + \frac{27x}{8} - \frac{20x^3}{2} + \frac{12x}{2} \end{aligned}$$

$$= \cancel{\frac{315x^5}{8}} - \cancel{\frac{270x^3}{8}}$$

$$= \frac{315x^5}{8} - \frac{270x^3}{8} - \frac{80x^3}{8} + \frac{27x}{8} + \frac{48x}{8}$$

$$5P_5 = \frac{315x^5}{8} - \frac{350x^3}{8} + \frac{75x}{8}$$

$$\text{so } P_5 = \frac{315x^5}{5 \cdot 8} - \frac{350x^3}{5 \cdot 8} + \frac{75x}{5 \cdot 8} = \frac{63x^5}{8} - \frac{70x^3}{8} + \frac{15x}{8}$$

$$P_5 = \frac{1}{8} (63x^5 - 70x^3 + 15x)$$

for P_6 , $l=6$

$$\begin{aligned} \text{so } 6P_6 &= 11xP_5 - 5P_4 \\ &= 11x \left(\frac{63}{8}x^5 - \frac{70}{8}x^3 + \frac{15}{8}x \right) - 5 \left(\frac{35}{8}x^4 - \frac{30}{8}x^2 + \frac{3}{8} \right) \\ &= \left(\frac{693x^6}{8} - \frac{770x^4}{8} + \frac{165x^2}{8} \right) - \frac{175x^4}{8} + \frac{150x^2}{8} - \frac{15}{8} \end{aligned}$$

$$\Rightarrow P_6 = \frac{1}{16} \left(231x^6 - 315x^4 + 105x^2 - 5 \right)$$

(2)

ch 12

5.5

Differentiate (5.8a) and use recursion relation 5.8b with l replaced by $l-1$ to prove 5.8c.

5.8a is given by $l P_l(x) = (2l-1)x P_{l-1}' - (l-1)P_{l-2}$

5.8b is $x P_l' - P_{l-1}' = l P_l$

5.8c is $P_l' - x P_{l-1}' = l P_{l-1}$

differentiate 5.8a, we set

$$l P_l' = (2l-1)x P_{l-1}' + (2l-1)P_{l-1} - (l-1)P_{l-2}' \quad \text{--- (1)}$$

from 5.8b, replace l by $l-1$, we set

$$x P_{l-1}' - P_{l-2}' = (l-1)P_{l-1}$$

$$\text{or } P_{l-2}' = x P_{l-1}' - (l-1)P_{l-1} \quad \text{--- (2)}$$

Plug (2) into (1) to remove P_{l-2}' term in (1), we set

$$l P_l' = (2l-1)x P_{l-1}' + (2l-1)P_{l-1} - (l-1)[x P_{l-1}' - (l-1)P_{l-1}]$$

expand and simplify:

$$l P_l' = 2lx P_{l-1}' - x P_{l-1}' + 2lx P_{l-1} - P_{l-1} - lx P_{l-1}' + l(l-1)P_{l-1} + x P_{l-1}' - (l-1)P_{l-1}$$

→

(22)

$$lP'_l = 2lx P'_{l-1} - x P'_{l-1} + 2lP_{l-1} - P_{l-1} - lx P'_{l-1} + l^2 P_{l-1} - lP_{l-1} + x P'_{l-1} - lP_{l-1} + P_{l-1}$$

$$lP'_l = 2lx P'_{l-1} - lx P'_{l-1} + l^2 P_{l-1}$$

$$P'_l = x P'_{l-1} + l P_{l-1}$$

$$\text{or } \boxed{P'_l - x P'_{l-1} = l P_{l-1}}$$

(23)

ch 12

5.6

From 5.8b and 5.8c obtain 5.8d. Then differentiate 5.8d and eliminate P'_{l-1} using 5.8b. Your result should be the Legendre equation.

$$5.8b: x P'_l - P'_{l-1} = l P_l$$

$$5.8c: P'_l - x P'_{l-1} = l P_{l-1}$$

$$5.8d: (1-x^2) P'_l = l P_{l-1} - l x P_l$$

multiply 5.8b by x and $5.8c - 5.8b$ leads to

$$x^2 P'_l - x P'_{l-1} = x l P_l$$

$$P'_l - x P'_{l-1} = l P_{l-1}$$

$$(1-x^2) P'_l = l P_{l-1} - x l P_l \quad \text{which is 5.8d.}$$

differentiate 5.8d, we get

$$(1-x^2) P''_l + P'_l (-2x) = l P'_{l-1} - [x l P'_l + l P_l]$$

$$(1-x^2) P''_l - 2x P'_l = l P'_{l-1} - x l P'_l - l P_l$$

eliminate P'_{l-1} in above equation by using 5.8b

from 5.8b, $P'_{l-1} = x P'_l - l P_l$. hence substitute in to get.

$$(1-x^2) P''_l - 2x P'_l = l [x P'_l - l P_l] - x l P'_l - l P_l$$

$$(1-x^2) P''_l - 2x P'_l = l x P'_l - l^2 P_l - x l P'_l - l P_l$$

$$(1-x^2) P''_l - 2x P'_l + l(l+1) P_l = 0 \quad \text{which is the Legendre equation.}$$

ch 12

5.7

write 5.8c with l replaced by $l+1$ and use it to eliminate the xP'_l term in 5.8b. you should get 5.8e.

$$5.8c: P'_l - xP'_{l-1} = lP_{l-1}$$

$$5.8b: xP'_l - P'_{l-1} = lP_l$$

$$5.8e: (2l+1)P_l = P'_{l+1} - P'_{l-1}$$

replace l with $l+1$ in 5.8c, we get

$$P'_{l+1} - xP'_l = (l+1)P_l$$

$$\Rightarrow xP'_l = P'_{l+1} - (l+1)P_l \quad \text{①}$$

sub ① into 5.8b

$$[P'_{l+1} - (l+1)P_l] - P'_{l-1} = lP_l$$

$$P'_{l+1} - (l+1)P_l - P'_{l-1} = lP_l \quad \checkmark$$

$$\begin{aligned} P'_{l+1} - P'_{l-1} &= lP_l + (l+1)P_l \\ &= lP_l + lP_l + P_l \\ &= 2lP_l + P_l \quad \checkmark \end{aligned}$$

$$\boxed{P'_{l+1} - P'_{l-1} = P_l(2l+1)}$$

which is 5.8e.

(25)

ch 12

5.11 express $x-x^3$ as a linear combination of Legendre polynomials.

$$f(x) = x - x^3$$

$$P_3 = \frac{1}{2}(5x^3 - 3x)$$

$$\text{so } P_3 = \frac{5}{2}x^3 - \frac{3}{2}x$$

$$\frac{5}{2}x^3 = P_3 + \frac{3}{2}x$$

$$\boxed{x^3 = \frac{2}{5}P_3 + \frac{3}{5}x}$$

$$\text{so } f(x) = x - \left[\frac{2}{5}P_3 + \frac{3}{5}x \right] = -\frac{2}{5}P_3 + x - \frac{3}{5}x = -\frac{2}{5}P_3 + \frac{2}{5}x$$

$$f(x) = \frac{2}{5}(x - P_3) \quad \textcircled{1}$$

now $P_1 = 1-x$ or $x = 1 - P_1$

hence $f(x) = \frac{2}{5}((1 - P_1) - P_3) = \frac{2}{5}(1 - P_1 - P_3)$

~~$\therefore \boxed{x - x^3 = \frac{2}{5}(1 - P_1 - P_3)}$ opps.~~

now $P_1 = x$, hence from $\textcircled{1}$ we set

$$\text{so } f(x) = \frac{2}{5}(P_1 - P_3)$$

$$\therefore \boxed{x - x^3 = \frac{2}{5}(P_1 - P_3)}$$

4.4 HW 4

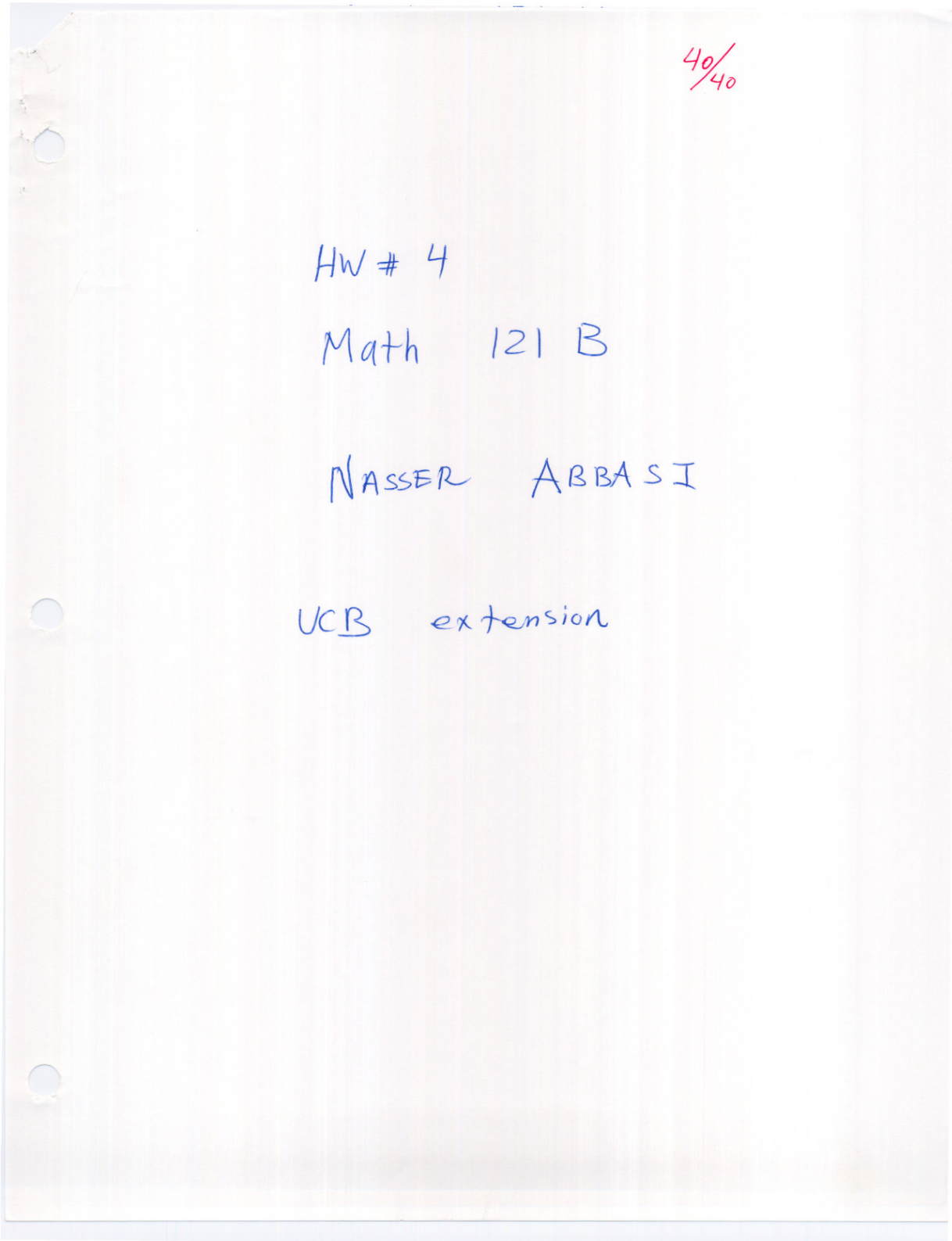

ch 12

6.4 show that functions $f(x)$ and $g(x)$ are orthogonal on $(-a, a)$ if $f(x)$ is even and $g(x)$ is odd. (1)

$$\begin{aligned} \text{inner product} &= \int_{-a}^a f(x) g(x) dx \\ &= \int_{-a}^a \text{even function} \times \text{odd function} dx \\ &= \int_{-a}^a \text{odd function} dx. \end{aligned}$$

$$\text{but } \int_{-a}^a \text{odd function} dx = 0$$

$$\text{hence } \int_{-a}^a f(x) g(x) dx = 0$$

hence $f(x), g(x)$ are orthogonal to each other over $(-a, a)$.

6.5 evaluate $\int_{-1}^1 P_0(x) P_2(x) dx$ to show they are orthogonal.

$$P_0(x) = 1$$

$$P_2(x) = \frac{1}{2}(3x^2 - 1)$$

$$\begin{aligned} \Rightarrow \int_{-1}^1 1 \cdot \frac{1}{2}(3x^2 - 1) dx &= \frac{1}{2} \left[\left(\frac{3x^3}{3} \right)_{-1}^1 - (x)_{-1}^1 \right] \\ &= \frac{1}{2} \left[(1 - (-1)^3) - (1 - (-1)) \right] \\ &= \frac{1}{2} \left[(1 - (-1)) - (1 + 1) \right] \\ &= \frac{1}{2} \left[2 - 2 \right] = 0 \quad \checkmark \end{aligned}$$

hence $P_0(x), P_2(x)$ are orthogonal over $(-1, 1)$

Ch 12

6.6 Show in two ways that $P_l(x)$ and $P_l'(x)$ are orthogonal on $(-1, 1)$.

first way:

$P_l(x)$ is either odd or even function. if $l=1, 3, 5, \dots$ i.e. is odd, then $P_l(x)$ is odd. if $l=2, 4, 6, \dots$ i.e. even, then $P_l(x)$ is even.

now if $P_l(x)$ is even, then $P_l'(x)$ is odd. this is because $P_l(x)$ is a polynomial of terms in x with exponents that are all either even or odd. similarly if $P_l(x)$ is odd then $P_l'(x)$ is even.

$$\text{hence } \int_{-1}^1 P_l(x) P_l'(x) dx \begin{cases} \rightarrow \int_{-1}^1 \text{even} \times \text{odd} \\ \text{or} \\ \rightarrow \int_{-1}^1 \text{odd} \times \text{even} \end{cases}$$

in both cases we get $\int_{-1}^1 \text{odd function } dx = 0$

hence $P_l(x), P_l'(x)$ are orthogonal over $(-1, 1)$.

Second way:

using relationship $\int_{-1}^1 x^m P_l(x) dx = 0$ if $m < l$.

now degree of $P_l'(x)$ is ^{one} less than degree of $P_l(x)$, since derivatives lowers degree (order) of polynomial.

now I integrate $\int_{-1}^1 P_l'(x) P_l(x) dx$ term by term as this:

$$\int_{-1}^1 (\text{first term in } P_l'(x) + \text{second term} + \dots + \text{last term}) P_l(x) dx$$

now each term of $P_l'(x)$ is of the form ax^m . since $m < l$ from as mentioned above, we set

$$\int_{-1}^1 (P_l' \text{ 1st term}) P_l(x) + \int_{-1}^1 (P_l' \text{ 2nd term}) P_l(x) + \dots$$

(3)

and all these integrals are of the form

$$\text{some constant} \int_{-1}^1 x^m P_l(x) dx$$

where $m < l$. (actually largest m value is $l-1$)

hence we get

$$0 + 0 + 0 + \dots = 0$$

$$\text{i.e.} \int_{-1}^1 P_l'(x) P_l(x) dx = 0$$

hence P_l' and P_l are orthogonal on $(-1, 1)$.

(Ps. please see problem 7.3 solution next for the same argument (written more clearly than here) which shows that $\int_{-1}^1 P_m P_l = 0$ when $m < l$

and this is the same as saying $\int_{-1}^1 P_l' P_l dx = 0$ since order of P_l' is less than order of P_l .)

ch 12
 7.3 use problem 4.4 to show that $\int_{-1}^1 P_m P_l dx = 0$. (4)
 if $m < l$.

in 4.4, we showed that $\int_{-1}^1 x^m P_l dx = 0$ if $m < l$.

write $P_m(x) = f_1(x) + f_2(x) + \dots + f_m(x)$.

where each $f(x)$ is of the form $a x^u$, where a is some constant, and u is an exponent which can be zero for f_1 term. (if P_m is even, then $f_1(x)$ is a constant, if P_m is odd then $f_1(x) = ax$).

$$\begin{aligned} \text{so now we write } \int_{-1}^1 P_m P_l dx &= \int_{-1}^1 (f_1 + f_2 + f_3 + \dots + f_m) P_l dx \\ &= \int_{-1}^1 f_1(x) P_l(x) dx + \int_{-1}^1 f_2(x) P_l(x) dx + \dots + \int_{-1}^1 f_m(x) P_l(x) dx. \\ &= a_1 \int_{-1}^1 x^{n_1} P_l(x) dx + a_2 \int_{-1}^1 x^{n_2} P_l(x) dx + \dots + a_m \int_{-1}^1 x^{n_m} P_l(x) dx. \end{aligned}$$

where we have each exponent $n_i < l$ as given.

hence by applying 4.4, we set 0 for each integral.

if the first term of $P_m(x)$ was a constant (i.e. $P_m(x)$ was even), then we set $\int_{-1}^1 P_l(x) dx$ for the first integral, which is also zero. (see proof of this last part in problem 7.5 next)

$$\text{hence } \int_{-1}^1 P_m P_l dx = 0 \text{ if } m < l.$$

Ch 12
7.5

show that $\int_{-1}^1 P_l(x) dx = 0$ $l > 0$

(5)

This can be shown immediately by applying result of Problem 4.4 which said $\int_{-1}^1 x^m P_l dx = 0$

when $m < l$.

Let $m=0$ here and the result follows.

Another proof is to write $\int_{-1}^1 P_l dx$ as

$$\int_{-1}^1 P_0 P_l dx, \text{ since } P_0 = 1.$$

now apply orthogonality principle for Legendre polynomials which says that $\int_{-1}^1 P_n P_m dx = 0$ $n \neq m$,

and since here $n=0$ and $m=l > 0$, then $m \neq n$,

$$\text{hence } \int_{-1}^1 P_l dx = 0.$$

ch 12
 [8.2] Find the norm of each following function on given interval and state the normalized function.

$P_2(x)$ on $(-1, 1)$

$$N^2 = \int_{-1}^1 P_2^*(x) P_2(x) dx = \frac{2}{2(2)+1} = \frac{2}{5}$$

so Norm of $P_2(x) = \boxed{\sqrt{\frac{2}{5}}}$

hence the normalized $P_2(x) = \frac{P_2(x)}{N} = \frac{P_2(x)}{\sqrt{\frac{2}{5}}}$

$$= \sqrt{\frac{5}{2}} \left(\frac{1}{2} (3x^2 - 1) \right) = \boxed{\frac{\sqrt{10}}{4} (3x^2 - 1)}$$

ch 12

9.1

Expand following function in Legendre series.

$$f(x) = \begin{cases} -1 & -1 < x < 0 \\ 1 & 0 < x < 1 \end{cases}$$

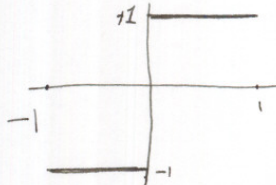

use 3 terms.

$$f(x) = a_0 P_0 + a_1 P_1 + a_2 P_2$$

$$\text{where } a_i = \frac{\int_{-1}^1 f(x) P_i(x) dx}{\int_{-1}^1 P_i(x) P_i(x) dx} = \frac{\int_{-1}^0 (-1) P_i(x) dx + \int_0^1 (+1) P_i(x) dx}{\frac{2}{2i+1}}$$

$$a_0 = \frac{-\int_{-1}^0 P_0 dx + \int_0^1 P_0 dx}{\frac{2}{1}} = \frac{-\int_{-1}^0 1 dx + \int_0^1 1 dx}{2} = \frac{-[x]_{-1}^0 + [x]_0^1}{2} \\ = \frac{-[+1] + [1]}{2} = \boxed{0}$$

$$a_1 = \frac{-\int_{-1}^0 P_1 dx + \int_0^1 P_1 dx}{\frac{2}{2+1}} = \frac{-\int_{-1}^0 x dx + \int_0^1 x dx}{\frac{2}{3}} = \frac{-[\frac{x^2}{2}]_{-1}^0 + [\frac{x^2}{2}]_0^1}{\frac{2}{3}} \\ = \frac{-\frac{1}{2}[0-1] + \frac{1}{2}[1-0]}{\frac{2}{3}} = \frac{\frac{1}{2} + \frac{1}{2}}{\frac{2}{3}} = \boxed{\frac{3}{2}}$$

$$a_2 = \frac{-\int_{-1}^0 \frac{1}{2}(3x^2-1) dx + \int_0^1 \frac{1}{2}(3x^2-1) dx}{\frac{2}{4+1}} = \frac{-\frac{1}{2} [\frac{3x^3}{3} - x]_{-1}^0 + \frac{1}{2} [\frac{3x^3}{3} - x]_0^1}{\frac{2}{5}} \\ = \frac{-\frac{1}{2} [(0-0) - (-1^3 - (-1))] + \frac{1}{2} [(1-1) - (0-0)]}{\frac{2}{5}} = \frac{-\frac{1}{2} [0] + \frac{1}{2} [0]}{\frac{2}{5}} = \boxed{0}$$

$$\text{So } f(x) \approx \frac{3}{2} P_1 = \frac{3}{2} x$$

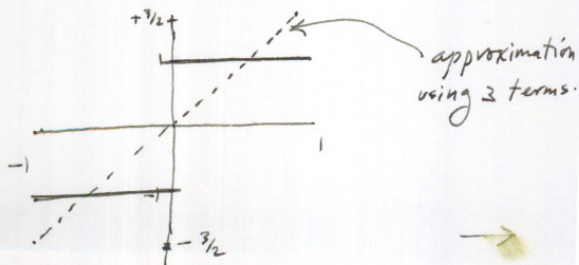

let me try and see if we add one more term (7)

$$a_3 = \frac{-\int_{-1}^0 P_3(x) dx + \int_0^1 P_3(x) dx}{6+1} = \frac{-\int_{-1}^0 \left(-\frac{3x}{2} + \frac{5x^3}{2}\right) dx + \int_0^1 \left(-\frac{3x}{2} + \frac{5x^3}{2}\right) dx}{2/7}$$

I just realized that I could do this faster by noting that

$$\int_{-1}^0 \text{even } P_k = \int_0^1 \text{even } P_k. \quad \text{so all even } a\text{'s} = 0$$

~~so I only need to integrate once over $(-1, 0)$ or $(0, 1)$.~~

also $\int_{-1}^0 \text{odd } P_k = -\int_0^1 \text{odd } P_k$. so all $a\text{'s}$ that are odd need integrate only from $(-1, 0)$ and multiply by 2 to get result. (sorry for not seeing this earlier!)

$$a_3 = \frac{2 \int_{-1}^0 P_3(x) dx}{2/7} = \frac{2 \int_{-1}^0 \left(-\frac{3x}{2} + \frac{5x^3}{2}\right) dx}{2/7}$$

$$= \frac{2 \left[-\frac{3}{2} \frac{x^2}{2} + \frac{5}{2} \frac{x^4}{4} \right]_{-1}^0}{2/7} = \frac{2 \left[\left(-\frac{3}{4}(0) + \frac{5}{8}(0)\right) - \left(-\frac{3}{4}(-1)^2 + \frac{5}{8}(-1)^4\right) \right]}{2/7}$$

$$= 7 \left[0 - \left(-\frac{3}{4} + \frac{5}{8}\right) \right] = 7 \left[\frac{3}{4} - \frac{5}{8} \right] = 7 \left[\frac{1}{8} \right] = \frac{7}{8}$$

$$\text{So } f(x) \approx \frac{3}{2}x + \frac{7}{8} \left(-\frac{3}{2}x + \frac{5x^3}{2}\right)$$

$$\approx \frac{3}{2}x - \frac{21}{16}x + \frac{35}{16}x^3 = \frac{3}{16}x + \frac{35}{16}x^3$$

$$= \frac{1}{16} (3x + 35x^3)$$

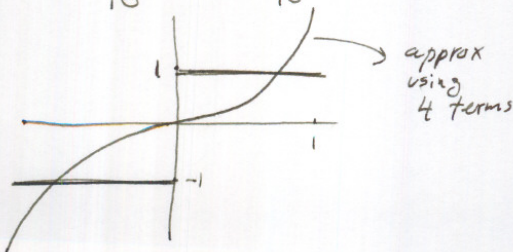

ch 12
9.6

Expand by Legendre series using 2 terms.

$$f(x) = \begin{cases} 0 & (-1, 0) \\ (\ln \frac{1}{x})^2 & (0, 1) \end{cases}$$

$$\tilde{f}(x) = a_0 P_0 + a_1 P_1$$

$$\text{where } a_n = \frac{\int_{-1}^1 f(x) P_n(x) dx}{\frac{2}{2n+1}}$$

since $f(x) = 0$ over $(-1, 0)$, integration is only needed from $(0, 1)$.

$$a_0 = \frac{\int_0^1 f(x) P_0(x) dx}{2} = \frac{1}{2} \int_0^1 (\ln \frac{1}{x})^2 \cdot 1 dx$$

$$\text{let } \ln \frac{1}{x} = u \rightarrow \frac{du}{dx} = -\frac{1}{x} \rightarrow dx = -x du$$

$$\begin{cases} e^u = \frac{1}{x} \Rightarrow x = e^{-u} & \text{so } dx = -e^{-u} du. \end{cases}$$

when $x=0$, $u=\infty$. when $x=1$, $u=0$

$$\text{so } a_0 = \frac{1}{2} \int_{\infty}^0 u^2 (-e^{-u}) du = \frac{1}{2} \int_0^{\infty} u^2 e^{-u} du = \frac{1}{2} \Gamma(3) = \frac{1}{2} 2! = 1$$

$$\text{To find } a_1 \quad a_1 = \frac{\int_0^1 f(x) P_1(x) dx}{\frac{2}{3}} = \frac{3}{2} \int_0^1 (\ln \frac{1}{x})^2 x dx$$

$$\text{let } x = e^{-u} \rightarrow \frac{dx}{du} = -e^{-u}$$

when $x=0 \rightarrow u=\infty$, when $x=1 \rightarrow u=0$

$$\ln \frac{1}{x} = \ln \frac{1}{e^{-u}} = \ln e^u = u$$

$$\text{so } a_1 = \frac{3}{2} \int_{\infty}^0 u^2 e^{-u} (-e^{-u}) du = \frac{3}{2} \int_0^{\infty} u^2 e^{-2u} du$$

$$\text{but } \int_0^{\infty} u^n e^{-au} du = \frac{n!}{a^{n+1}} \quad \text{from equation 2.2 page 458 book.}$$

$$\text{so } a_1 = \frac{3}{2} \left(\frac{2!}{2^3} \right) = \frac{3}{2} \left(\frac{1}{4} \right) = \frac{3}{8}$$

$$\text{hence } \tilde{f}(x) = a_0 P_0 + a_1 P_1 = \boxed{1 + \frac{3}{8} x} \rightarrow$$

$$\text{hence } f(x) \approx a_0 P_0 + a_1 P_1$$

$$= 1.1 + \frac{3}{8}x = 1 + \frac{3}{8}x$$

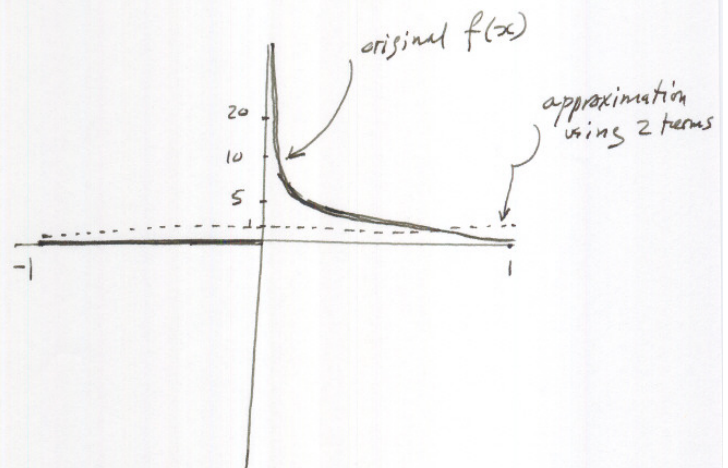

$$\begin{aligned} \text{when } x = -1 & \quad \tilde{f}(x) = 1 - \frac{3}{8} = \frac{5}{8} \\ \text{when } x = 0 & \quad \tilde{f}(x) = 1 \\ \text{when } x = 1 & \quad \tilde{f}(x) = 1 + \frac{3}{8} = \frac{11}{8} \end{aligned}$$

ch 12

9.11

Expand in Legendre polynomials

$$f(x) = 7x^4 - 3x + 1$$

This is a degree 4 polynomial. hence best fit will only require using up to P_4 Legendre Basis. (This is because $\int_{-1}^1 P_\ell (any poly degree < \ell) = 0$ hence no need to try more than P_5 and higher)

$$i.e \quad \tilde{f}(x) = a_0 P_0 + a_1 P_1 + a_2 P_2 + a_3 P_3 + a_4 P_4$$

where

$$a_n = \frac{\int_{-1}^1 f(x) P_n(x) dx}{\frac{2}{2n+1}}$$

$$a_0 = \frac{\int_{-1}^1 (7x^4 - 3x + 1) \cdot 1 dx}{2} = \frac{1}{2} \left(\left[\frac{7x^5}{5} \right]_{-1}^1 - 3 \left[\frac{x^2}{2} \right]_{-1}^1 + \left[x \right]_{-1}^1 \right)$$

$$= \frac{1}{2} \left(\frac{7}{5} (1 - (-1)^5) - \frac{3}{2} (1 - (-1)^2) + 2 \right) = \frac{1}{2} \left(\frac{7}{5} (2) - \frac{3}{2} (0) + 2 \right) = \boxed{\frac{12}{5}}$$

$$a_1 = \frac{\int_{-1}^1 (7x^4 - 3x + 1) x dx}{\frac{2}{3}} = \frac{3}{2} \left[7 \left(\frac{x^6}{6} \right)_{-1}^1 - 3 \left(\frac{x^3}{3} \right)_{-1}^1 + \left(\frac{x^2}{2} \right)_{-1}^1 \right]$$

$$= \frac{3}{2} \left[\frac{7}{6} (1 - (-1)^6) - (1 - (-1)^3) + \frac{1}{2} (1 - (-1)^2) \right] = \frac{3}{2} \left[\frac{7}{6} (0) - (2) + \frac{1}{2} (0) \right]$$

$$= \boxed{-3}$$

$$a_2 = \frac{\int_{-1}^1 (7x^4 - 3x + 1) \cdot \frac{1}{2}(3x^2 - 1) dx}{\frac{2}{5}} = \frac{5}{2} \int_{-1}^1 21x^6 - 7x^4 - 9x^3 + 3x + 3x^2 - 1 dx$$

$$= \frac{5}{4} \left(21 \left(\frac{x^7}{7} \right)_{-1}^1 - 7 \left(\frac{x^5}{5} \right)_{-1}^1 - 9 \left(\frac{x^4}{4} \right)_{-1}^1 + 3 \left(\frac{x^2}{2} \right)_{-1}^1 + 3 \left(\frac{x^3}{3} \right)_{-1}^1 - \left(x \right)_{-1}^1 \right)$$

$$= \frac{5}{4} \left(\frac{21}{7} (1 - (-1)^7) - \frac{7}{5} (1 - (-1)^5) - \frac{9}{4} (1 - (-1)^4) + \frac{3}{2} (1 - (-1)^2) + (1 - (-1)^3) - (1 - (-1)) \right)$$

$$= \frac{5}{4} \left(\frac{21}{7} (2) - \frac{7}{5} (2) - \frac{9}{4} (0) + \frac{3}{2} (0) + (2) - (2) \right) = \frac{5}{4} \left(\frac{42}{7} - \frac{14}{5} \right) = \frac{5}{4} \left(\frac{210}{35} - \frac{98}{35} \right)$$

$$= \frac{5}{4} \left(\frac{112}{35} \right) = \boxed{\frac{14}{5}}$$

$$\begin{aligned}
 a_3 &= \frac{\int_{-1}^1 (7x^4 - 3x + 1) \left(-\frac{3}{2}x + \frac{5}{2}x^3\right) dx}{\frac{2}{7}} \quad (11) \\
 &= \frac{7}{2} \int_{-1}^1 -21x^5 + 35x^7 + 9x^2 - 15x^4 - 3x + 5x^3 dx \\
 &= \frac{7}{4} \left(-2 \left(\frac{x^6}{6}\right) \Big|_{-1}^1 + 35 \left(\frac{x^8}{8}\right) \Big|_{-1}^1 + 9 \left(\frac{x^3}{3}\right) \Big|_{-1}^1 - 15 \left(\frac{x^5}{5}\right) \Big|_{-1}^1 - 3 \left(\frac{x^2}{2}\right) \Big|_{-1}^1 + 5 \left(\frac{x^4}{4}\right) \Big|_{-1}^1 \right) \\
 &= \frac{7}{4} \left(-\frac{1}{3}(1 - (-1)^6) + \frac{35}{8}(1 - (-1)^8) + 3(1 - (-1)^3) - 3(1 - (-1)^5) - \frac{3}{2}(1 - (-1)^2) + \frac{5}{4}(1 - (-1)^4) \right) \\
 &= \frac{7}{4} \left(-\frac{1}{3}(0) + \frac{35}{8}(0) + 3(2) - 3(2) - \frac{3}{2}(0) + \frac{5}{4}(0) \right) = \frac{7}{4} (6 - 6) = \boxed{0}
 \end{aligned}$$

$$\begin{aligned}
 a_4 &= \frac{\int_{-1}^1 (7x^4 - 3x + 1) \left(\frac{1}{8}(3 - 30x^2 + 35x^4)\right) dx}{\frac{2}{9}} \\
 &= \frac{9}{2} \frac{1}{8} \int_{-1}^1 21x^4 - 210x^6 + 245x^8 - 9x + 90x^3 - 95x^5 + 3 - 30x^2 + 35x^4 dx \\
 &= \frac{9}{16} \left[21 \left(\frac{x^5}{5}\right) - 210 \left(\frac{x^7}{7}\right) + 245 \left(\frac{x^9}{9}\right) - 9(0) + 90 \left(\frac{x^4}{4}\right) - 95 \left(\frac{x^6}{6}\right) + 3(2) - 30 \left(\frac{x^3}{3}\right) + 35 \left(\frac{x^5}{5}\right) \right]_{-1}^1 \\
 &= \frac{9}{16} \left(\frac{42}{5} - \frac{420}{7} + \frac{490}{9} + 6 - 20 + 14 \right) = \frac{9}{16} \left(\frac{128}{45} \right) = \boxed{\frac{8}{5}}
 \end{aligned}$$

$$\begin{aligned}
 \text{so } \tilde{f}(x) &= a_0 P_0 + a_1 P_1 + a_2 P_2 + a_3 P_3 + a_4 P_4 = \boxed{\frac{12}{5} P_0 - 3 P_1 + 4 P_2 + 0 P_3 + \frac{8}{5} P_4} \\
 &= \frac{12}{5}(1) - 3(x) + 4\left(\frac{3}{2}x^2 - \frac{1}{2}\right) + 0 + \frac{8}{5}\left(\frac{1}{8}(3 - 30x^2 + 35x^4)\right)
 \end{aligned}$$

$$\begin{aligned}
 &= \frac{7}{5} - 3x + 6x^2 - 2 + \frac{3}{5} - \frac{30}{5}x^2 + 7x^4 \\
 \tilde{f}(x) &= 7x^4 - x^2 - 3x + 1
 \end{aligned}$$

$$= \frac{12}{5} - 3x + 6x^2 - 2 + \frac{3}{5} - \frac{30}{5}x^2 + 7x^4$$

$$\tilde{f}(x) = 7x^4 - x^2 - 3x + 1$$

note: 2 roots of $f(x)$ are real. the other 2 roots are complex.

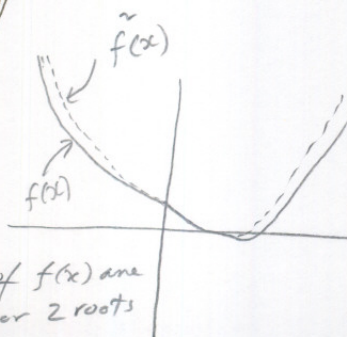

Ch 112

9.14

Find the best fit (in least square sense)

Second order degree polynomial approximation to each of these functions for $-1 < x < 1$ $|x|$ 

Least square fit of a polynomial is the same as expanding the polynomial using Legendre polynomials. This was proved in class notes and in problem 9.16, page 507.

So I need to expand $|x|$ in Legendre polynomials. Since we want a second degree polynomial, then

$$\tilde{f}(x) = a_0 P_0 + a_1 P_1 + a_2 P_2 \quad \text{where } a_n = \frac{\int_{-1}^1 f(x) P_n}{\frac{2}{2n+1}}$$

$$a_0 = \frac{\int_{-1}^1 |x| P_0 dx}{2} = \frac{1}{2} \left(2 \int_0^1 x dx \right) = \left[\frac{x^2}{2} \right]_0^1 = \frac{1}{2} [1 - 0] = \boxed{\frac{1}{2}}$$

$$a_1 = \frac{\int_{-1}^1 |x| P_1 dx}{\frac{2}{3}} = \frac{3}{2} \int_{-1}^1 \overset{\text{odd}}{\text{even } f \times \text{odd } f} dx = 0$$

$$\begin{aligned} a_2 &= \frac{\int_{-1}^1 |x| P_2}{\frac{2}{5}} = \frac{5}{2} \left(\int_{-1}^0 -x \left(\frac{3}{2} x^2 - \frac{1}{2} \right) + \int_0^1 x \left(\frac{3}{2} x^2 - \frac{1}{2} \right) \right) \\ &= \frac{5}{2} \left(- \left[\left(\frac{3}{2} \frac{x^4}{4} \right) - \frac{1}{2} \left(\frac{x^2}{2} \right) \right]_{-1}^0 + \left[\left(\frac{3}{2} \frac{x^4}{4} \right) - \frac{1}{2} \left(\frac{x^2}{2} \right) \right]_0^1 \right) \\ &= \frac{5}{2} \left(- \left[\frac{3}{8} (0 - (-1)^4) + \frac{1}{4} (0 - (-1)^2) \right] + \left[\frac{3}{8} (1 - 0) - \frac{1}{4} (1 - 0) \right] \right) \\ &= \frac{5}{2} \left(- \left[\frac{3}{8} (-1) + \frac{1}{4} (-1) \right] + \left[\frac{3}{8} - \frac{1}{4} \right] \right) = \frac{5}{2} \left[- \left(-\frac{3}{8} - \frac{1}{4} \right) + \left(\frac{1}{8} \right) \right] \\ &= \frac{5}{2} \left(- \left(-\frac{5}{8} \right) + \frac{1}{8} \right) = \frac{5}{2} \left(\frac{5}{8} + \frac{1}{8} \right) = \frac{5}{2} \left(\frac{6}{8} \right) = \boxed{\frac{15}{8}} \rightarrow \end{aligned}$$

(13)

$$\text{so } \hat{f}(x) = a_0 P_0 + a_1 P_1 + a_2 P_2$$

$$= \frac{1}{2} P_0 + 0 P_1 + \frac{15}{8} P_2$$

$$= \frac{1}{2} + \frac{15}{8} \left(\frac{3}{2} x^2 - \frac{1}{2} \right)$$

$$= \frac{1}{2} + \frac{45}{16} x^2 - \frac{15}{16} = \frac{45}{16} x^2 - \frac{7}{16} = \boxed{\frac{1}{16} (45x^2 - 7)}$$

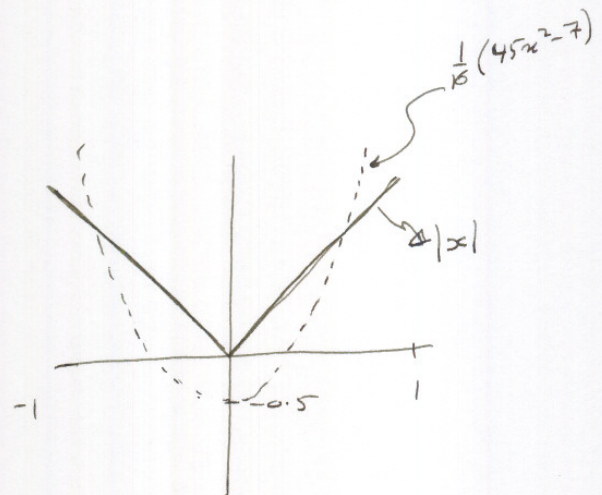

ch 12
10.1 verify equations (10.3) and (10.4)

$$(10.3) \quad (1-x^2) u'' - 2(m+1)x u' + [l(l+1) - m(m+1)] u = 0$$

$$(10.4) \quad (1-x^2)(u')' - 2[(m+1)] x(u')' + [l(l+1) - m(m+1)(m+2)] u' = 0$$

To verify (10.3) start with the associated Legendre DE:

$$(1-x^2) y'' - 2x y' + \left[l(l+1) - \frac{m^2}{1-x^2} \right] y = 0 \quad (1)$$

Substitute $y = (1-x^2)^{\frac{m}{2}} u$

$$\begin{aligned} \text{so } \frac{dy}{dx} &= \frac{d}{dx} \left((1-x^2)^{\frac{m}{2}} u \right) = \frac{d}{dx} u (1-x^2)^{\frac{m}{2}} + u \frac{d}{dx} \left((1-x^2)^{\frac{m}{2}} \right) \\ &= \frac{du}{dx} (1-x^2)^{\frac{m}{2}} + u \left(\frac{m}{2} (1-x^2)^{\frac{m}{2}-1} \cdot (-2x) \right) \end{aligned}$$

$$y' = \frac{du}{dx} (1-x^2)^{\frac{m}{2}} - \frac{u m x (1-x^2)^{\frac{m}{2}-1}}{1}$$

$$\text{and } \frac{d^2 y}{dx^2} = \frac{d}{dx} \left(\frac{du}{dx} (1-x^2)^{\frac{m}{2}} \right) - \frac{d}{dx} \left(u m x (1-x^2)^{\frac{m}{2}-1} \right)$$

$$= \frac{d^2 u}{dx^2} (1-x^2)^{\frac{m}{2}} + \frac{du}{dx} \left(\frac{m}{2} (1-x^2)^{\frac{m}{2}-1} (-2x) \right) - \left(\frac{du}{dx} m (1-x^2)^{\frac{m}{2}-1} x + \right)$$

$$\rightarrow u m \frac{d}{dx} \left(x (1-x^2)^{\frac{m}{2}-1} \right)$$

$$= \frac{d^2 u}{dx^2} (1-x^2)^{\frac{m}{2}} - \frac{du}{dx} m x (1-x^2)^{\frac{m}{2}-1} - \left(\frac{du}{dx} m x (1-x^2)^{\frac{m}{2}-1} + u m \left((1-x^2)^{\frac{m}{2}-1} + x \left(\frac{m}{2}-1 \right) (1-x^2)^{\frac{m}{2}-2} (-2x) \right) \right)$$

$$= u'' (1-x^2)^{\frac{m}{2}} - u' m x (1-x^2)^{\frac{m}{2}-1} - u' m x (1-x^2)^{\frac{m}{2}-1} - u m (1-x^2)^{\frac{m}{2}-1} + u m x \left(\frac{m}{2}-1 \right) (-2x) (1-x^2)^{\frac{m}{2}-2}$$

$$y'' = u'' (1-x^2)^{\frac{m}{2}} - u' m x (1-x^2)^{\frac{m}{2}-1} - u' m x (1-x^2)^{\frac{m}{2}-1} + u m (1-x^2)^{\frac{m}{2}-1} + 2 u m x^2 \left(\frac{m}{2}-1 \right) (1-x^2)^{\frac{m}{2}-2}$$

Substitute y', y'' above into (1)



$$(1-x^2) \left[u'' (1-x^2)^{\frac{m}{2}} - 2u'mx(1-x^2)^{\frac{m}{2}-1} - um(1-x^2)^{\frac{m}{2}-1} + 2umx^2(\frac{m}{2}-1)(1-x^2)^{\frac{m}{2}-2} \right] \\ - 2x \left[u'(1-x^2)^{\frac{m}{2}} - umx(1-x^2)^{\frac{m}{2}-1} \right] + \left[l(l+1) - \frac{m^2}{1-x^2} \right] (1-x^2)^{\frac{m}{2}} u = 0$$

divide by $(1-x^2)^{\frac{m}{2}-2}$ both sides of the equation. \Rightarrow

$$(1-x^2) \left[u'' (1-x^2)^2 - 2u'mx(1-x^2) - um(1-x^2) + 2umx^2(\frac{m}{2}-1) \right] \\ - 2x \left[u'x(1-x^2)^2 - umx^2(1-x^2) \right] + \left[l(l+1) - \frac{m^2}{1-x^2} \right] (1-x^2)^2 u = 0 \\ \Rightarrow u'' \left[(1-x^2)^3 \right] + u' \left[-2mx(1-x^2)^2 - 2x(1-x^2)^2 \right] \\ + u \left[-m(1-x^2)^2 + 2mx^2(\frac{m}{2}-1)(1-x^2) + 2mx^2(1-x^2) \right. \\ \left. + \left[l(l+1) - \frac{m^2}{1-x^2} \right] (1-x^2)^2 \right] = 0$$

divide by $(1-x^2)^2 \Rightarrow$

$$u'' (1-x^2) + u' (-2mx - 2x) \\ + u \left(-m + 2mx^2(\frac{m}{2}-1) \frac{1}{(1-x^2)} + 2mx^2 \frac{1}{(1-x^2)} + \left[l(l+1) - \frac{m^2}{1-x^2} \right] \right) = 0 \\ (1-x^2)u'' - 2(m+1)xu' + u \left(-m + \frac{2mx^2 \frac{m}{2} - 2mx^2}{(1-x^2)} + \frac{2mx^2}{1-x^2} + \left[\quad \right] \right) = 0 \\ (1-x^2)u'' - 2(m+1)xu' + u \left(-m + \frac{2mx}{1-x^2} (mx - 2x) + \frac{2mx^2}{1-x^2} + \left[\quad \right] \right) = 0 \\ (1-x^2)u'' - 2(m+1)xu' + u \left(-m + \frac{mx^2}{1-x^2} (m - 2 + 2) + l(l+1) - \frac{m^2}{1-x^2} \right) = 0$$

$$\underbrace{(1-x^2)u'' - 2(m+1)xu'} + u \left(-m + \frac{m^2x^2}{1-x^2} - \frac{m^2}{1-x^2} + l(l+1) \right) = 0$$

↓

$$+ u \left(-m + \frac{m^2(x^2-1)}{1-x^2} + l(l+1) \right) = 0$$

↓

$$+ u \left(-m - \frac{m^2(1-x^2)}{1-x^2} + l(l+1) \right) = 0$$

↓

$$+ u \left(-m - m^2 + l(l+1) \right) = 0$$

↓

$$+ u \left(l(l+1) - m(m+1) \right) = 0$$

hence we get

$$\boxed{(1-x^2)u'' - 2(m+1)xu' + [l(l+1) - m(m+1)]u = 0}$$

→

now verify (10.4)

$$\text{differentiate } (1-x^2)u'' - 2(m+1)xu' + [l(l+1) - m(m+1)]u = 0$$

$$-2xu'' + (1-x^2)(u'')' - 2(m+1)[xu'' + u'] + [l(l+1) - m(m+1)]u' = 0$$

$$(1-x^2)(u'')' + u''(-2x - 2(m+1)x) + u'(-2(m+1) - m(m+1) + l(l+1)) = 0$$

$$(1-x^2)(u'')' + u''(-2x - 2mx - 2x) + u'(\cancel{m(m+1)}(m+1)(-2-m) + l(l+1)) = 0$$

$$(1-x^2)(u'')' + u''x(-4 - 2m) + u'(-(m+1)(m+2) + l(l+1)) = 0$$

$$(1-x^2)(u'')' - 2[(m+1)+1]x(u'')' + [l(l+1) - (m+1)(m+2)]u' = 0$$

which is 10.4.

ch 12
 10.2 the equation for associated Legendre functions
 (and for Legendre functions when $m=0$) usually arises in
 the form
$$\frac{1}{\sin\theta} \frac{d}{d\theta} \left(\sin\theta \frac{dy}{d\theta} \right) + \left[l(l+1) - \frac{m^2}{\sin^2\theta} \right] y = 0 \quad (1)$$

make the change of variable $x = \cos\theta$ and obtain

$$(1-x^2)y'' - 2xy' + \left[l(l+1) - \frac{m^2}{1-x^2} \right] y = 0 \quad (2)$$

Solution

let $x = \cos\theta$ ~~in (1)~~

$$\frac{dx}{d\theta} = -\sin\theta \Rightarrow d\theta = -\frac{dx}{\sin\theta}$$

so also $\frac{dy}{d\theta}$ becomes $-\frac{dy}{dx} \sin\theta = -\sin\theta \frac{dy}{dx}$

hence using these, we substitute in (1)

$$\frac{1}{\sin\theta} \frac{d}{d\theta} \left(\sin\theta \left(-\sin\theta \frac{dy}{dx} \right) \right) + \left[l(l+1) - \frac{m^2}{1-\cos^2\theta} \right] y = 0$$

$$-\frac{\sin\theta}{\sin\theta} \frac{d}{dx} \left(-\sin^2\theta \frac{dy}{dx} \right) + \left[l(l+1) - \frac{m^2}{1-x^2} \right] y = 0$$

$$\frac{d}{dx} \left((1-\cos^2\theta) \frac{dy}{dx} \right) + \downarrow = 0$$

$$\frac{d}{dx} \left((1-x^2) \frac{dy}{dx} \right) + \downarrow = 0$$

$$-2x \frac{dy}{dx} + (1-x^2) \frac{d^2y}{dx^2} + \downarrow = 0$$

$$(1-x^2)y'' - 2xy' + \left[l(l+1) - \frac{m^2}{1-x^2} \right] y = 0$$

QED

ch 12
10.5

Find $P'_4 \cos \theta$ by substituting $P_4(x)$

$$P'_l = (1-x^2)^{\frac{m-l}{2}}$$

a

$$P_4(x) = \frac{1}{8} (3 - 30x^2 + 35x^4) \quad \text{found in problem 4.3.}$$

so $\boxed{l=4 \text{ and } m=1}$

hence

$$\begin{aligned} P'_4(x) &= (1-x^2)^{\frac{1}{2}} \frac{d}{dx} \left(\frac{1}{8} (3 - 30x^2 + 35x^4) \right) \\ &= \sqrt{1-x^2} \frac{1}{8} (-60x + 140x^3) \\ &= \sqrt{1-x^2} \frac{1}{2} (35x^3 - 15x) \end{aligned}$$

let $x = \cos \theta$.

$$P'_4(\cos \theta) = \sqrt{1-\cos^2 \theta} \frac{1}{2} (35 \cos^3 \theta - 15 \cos \theta)$$

$$\boxed{P'_4(\cos \theta) = \frac{1}{2} \sin \theta (35 \cos^3 \theta - 15 \cos \theta)}$$

4.5 HW 5

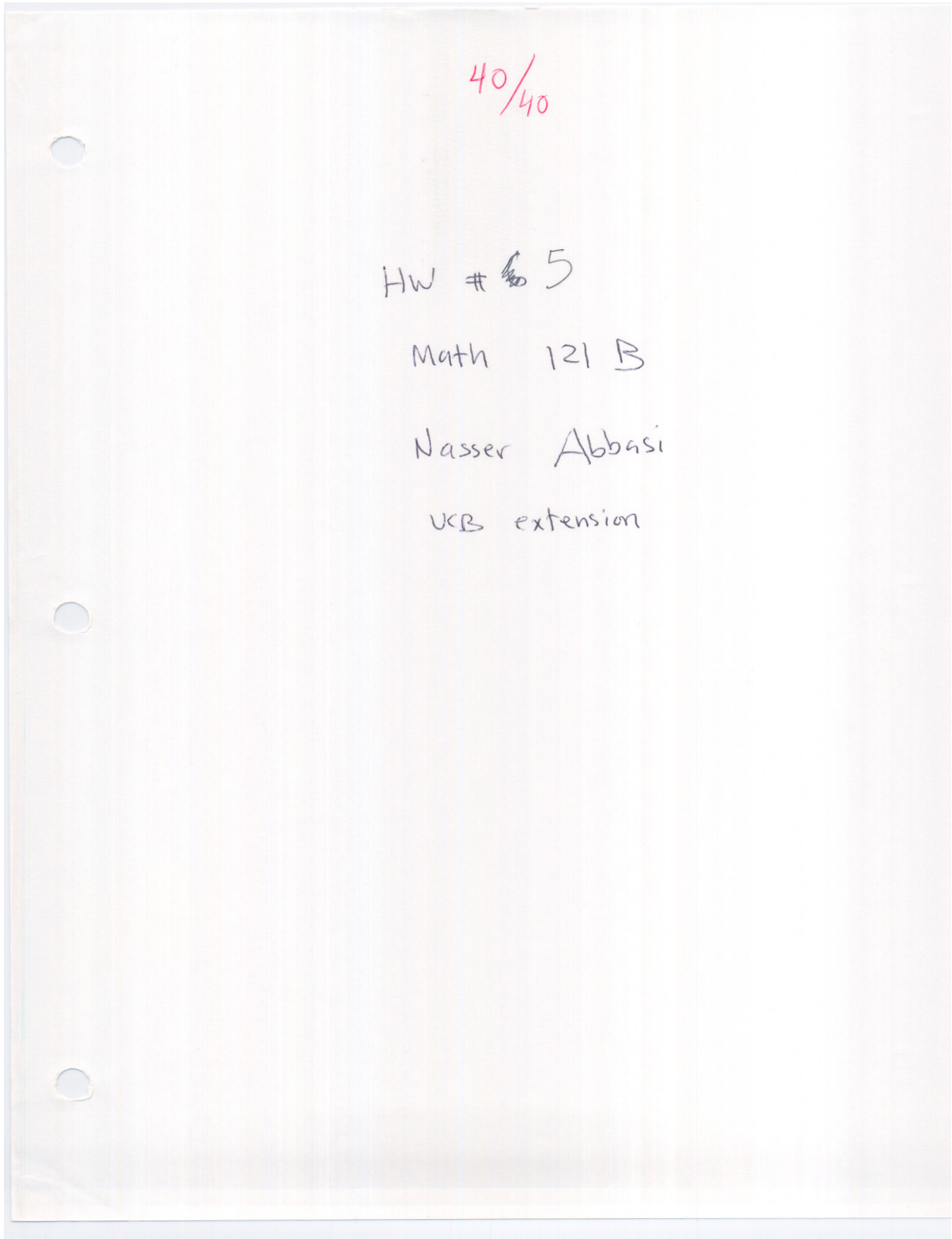

ch 12

P 11.2

Solve using method of Frobenius (generalized power series).

$$x^2 y'' + x y' - 9y = 0.$$

$$\text{let } y = a_0 x^s + a_1 x^{s+1} + a_2 x^{s+2} + a_3 x^{s+3} + \dots$$

$$y' = s a_0 x^{s-1} + a_1 (s+1) x^s + a_2 (s+2) x^{s+1} + \dots$$

$$y'' = s(s-1) a_0 x^{s-2} + a_1 (s+1)(s) x^{s-1} + a_2 (s+2)(s+1) x^s + \dots$$

$$\rightarrow x^2 y'' = s(s-1) a_0 x^s + a_1 (s+1)(s) x^{s+1} + a_2 (s+2)(s+1) x^{s+2} + \dots$$

$$\rightarrow x y' = s a_0 x^s + a_1 (s+1) x^{s+1} + a_2 (s+2) x^{s+2} + \dots$$

$$\rightarrow -9y = -9 a_0 x^s - 9 a_1 x^{s+1} - 9 a_2 x^{s+2} - \dots$$

now arrange Table:

	x^s	x^{s+1}	x^{s+2}	x^{s+n}
$x^2 y''$	$s(s-1) a_0$	$a_1 (s+1)(s)$	$a_2 (s+2)(s+1)$	$a_n (s+n)(s+n-1)$
$x y'$	$s a_0$	$a_1 (s+1)$	$a_2 (s+2)$	$a_n (s+n)$
$-9y$	$-9 a_0$	$-9 a_1$	$-9 a_2$	$-9 a_n$

total coeff. of each power = 0.

$$\text{from coeff for } x^s: \quad s(s-1) a_0 + s a_0 - 9 a_0 = 0$$

$$(s(s-1) + s - 9) a_0 = 0$$

since $a_0 \neq 0$ by hypothesis,

$$s(s-1) + s - 9 = 0$$

$$\text{or } s^2 - s + s - 9 = 0$$

$$\text{or } s^2 - 9 = 0 \Rightarrow$$

$$\boxed{s = \pm 3}$$



now looking at each column shows that each

$a_n = 0$ for $n > 0$. ✓ since no recursive formula.

so solutions are only

$$y = a_0 x^5$$

(and each column adds to zero, so we
set $K a_n = 0$ for some
 $K(n)$.

$$\Rightarrow a_n = 0$$

i.e. $y_1 = a_0 x^3$

or $y_2 = a_0 x^{-3}$ ✓

so general solution is $y = a_0 x^3 + a_0 x^{-3}$

or can be written as

$$y = A x^3 + B x^{-3}$$

A, B to be found from initial conditions.

Ch 12

v 11.6

use method of generalized power series to solve

$$3xy'' + (3x+1)y' + y = 0$$

writes as $3xy'' + 3xy' + y' + y = 0$.

$$\rightarrow \text{let } y = a_0 x^s + a_1 x^{s+1} + a_2 x^{s+2} + a_3 x^{s+3} + \dots$$

$$\rightarrow y' = s a_0 x^{s-1} + a_1 (s+1) x^s + a_2 (s+2) x^{s+1} + a_3 (s+3) x^{s+2} + \dots$$

$$\rightarrow 3xy' = 3s a_0 x^s + 3a_1 (s+1) x^{s+1} + 3a_2 (s+2) x^{s+2} + \dots$$

$$y'' = s(s-1) a_0 x^{s-2} + a_1 (s+1)s x^{s-1} + a_2 (s+2)(s+1) x^s + \dots$$

$$\rightarrow 3xy'' = 3s(s-1) a_0 x^{s-1} + 3a_1 (s+1)s x^s + 3a_2 (s+2)(s+1) x^{s+1} + \dots$$

Now set up the Table

	x^{s-1}	x^s	x^{s+1}	x^{s+n}
$3xy''$	$3s(s-1)a_0$	$3s(s+1)a_1$	$3(s+1)(s+2)a_2$	$3(s+n)(s+n+1)a_{n+1}$
$3xy'$	0	$3s a_0$	$3(s+1)a_1$	$3(s+n)a_n$
y'	$s a_0$	$(s+1)a_1$	$(s+2)a_2$	$(s+n+1)a_{n+1}$
y	0	a_0	a_1	a_n

First solve the indicial equation.

From first column, we set $3s(s-1)a_0 + s a_0 = 0$

or $a_0 (s + 3s(s-1)) = 0$

but $a_0 \neq 0$ by hypothesis. $\Rightarrow s + 3s^2 - 3s = 0$

$$3s^2 - 2s = 0 \rightarrow$$

(4)

$$S = \frac{-b \pm \sqrt{b^2 - 4ac}}{2a} = \frac{-(-2) \pm \sqrt{4 - 4(0)}}{2(3)}$$

$$= \frac{2 \pm 2}{6} = \frac{4}{6} \text{ or } 0$$

$$\text{ie } \boxed{S_1 = \frac{2}{3}, \quad S_2 = 0}$$

for $S_1 = \frac{2}{3}$

Recurrence equation is

$$3(s+n)(s+n+1)a_{n+1} + 3(s+n)a_n + (s+n+1)a_{n+1} + a_n = 0$$

$$a_{n+1} [3(s+n)(s+n+1) + (s+n+1)] = -a_n [1 + 3(s+n)]$$

$$a_{n+1} [3(\frac{2}{3}+n)(\frac{2}{3}+n+1) + (\frac{2}{3}+n+1)] = -a_n [1 + 3(\frac{2}{3}+n)]$$

$$a_{n+1} [(2+3n)(\frac{5}{3}+n) + (\frac{5}{3}+n)] = -a_n [1 + (2+3n)]$$

$$a_{n+1} [\frac{10}{3} + 2n + 5n + 3n^2 + \frac{5}{3} + n] = -a_n [3 + 3n]$$

$$a_{n+1} [\frac{15}{3} + 8n + 3n^2] = -a_n [3 + 3n]$$

$$a_{n+1} (5 + 8n + 3n^2) = -3a_n (1+n)$$

$$\boxed{a_{n+1} = \frac{-3a_n(1+n)}{5+8n+3n^2}}$$

→

5

for $n=0$

$$a_1 = \frac{-3a_0(1)}{5} = \boxed{-\frac{3}{5}a_0}$$

for $n=1$

$$a_2 = \frac{-3a_1(2)}{5+8+3} = \frac{-6}{16} \left(-\frac{3}{5}a_0\right) = \frac{18}{80}a_0 = \boxed{-\frac{9}{40}a_0}$$

for $n=2$

$$a_3 = \frac{-3a_2(3)}{5+8(2)+3(2^2)} = \frac{-9}{33} \left(\frac{9}{40}\right)a_0 = \frac{-81}{2640}a_0 = \frac{-81}{1320}a_0 = \boxed{-\frac{27}{440}a_0}$$

$$\text{so } y = a_0 x^s + a_1 x^{s+1} + a_2 x^{s+2} + \dots$$

$$y = a_0 x^{2/3} - \frac{3}{5}a_0 x^{5/3} + \frac{9}{40}a_0 x^{8/3} - \frac{27}{440}a_0 x^{11/3}$$

$$= a_0 \left(x^{2/3} - \frac{3}{5}x^{5/3} + \frac{9}{40}x^{8/3} - \frac{27}{440}x^{11/3} \right)$$

$$y_1 = a_0 x^{2/3} \left(1 - \frac{3}{5}x + \frac{9}{40}x^2 - \frac{27}{440}x^3 + \dots \right)$$

The above solution is for $s = 2/3$.

Now I need to find second solution for $s=0$.

from Recursive equation

$$a_{n+1} \cdot (3(s+n)(s+n+1) + (s+n+1)) = -a_n (1+3(s+n))$$

$$s=0 \Rightarrow a_{n+1} (3(n)(n+1) + (n+1)) = -a_n (1+3n)$$

$$a_{n+1} (3(n^2+n) + (n+1)) = -a_n (1+3n)$$

$$a_{n+1} (3n^2+4n+1) = -a_n (1+3n)$$

$$\Rightarrow \boxed{a_{n+1} = -\frac{a_n (1+3n)}{3n^2+4n+1}} \rightarrow$$

$$\underline{n=0} \quad a_1 = \frac{-a_0(1)}{1} = \boxed{-a_0}$$

$$\underline{n=1} \quad a_2 = -a_1 \left(\frac{1+3}{3+4+1} \right) = -\frac{4}{8} a_1 = -\frac{1}{2} (-a_0) = \boxed{\frac{a_0}{2}}$$

$$\underline{n=2} \quad a_3 = -a_2 \left(\frac{1+6}{3 \times 2^2 + 4 \times 2 + 1} \right) = \frac{7}{12+8+1} (-a_2)$$

$$= -\frac{7}{21} \left(\frac{a_0}{2} \right) = -\frac{7}{42} a_0 = \boxed{-\frac{1}{6} a_0}$$

$$\underline{n=3} \quad a_4 = -a_3 \left(\frac{1+9}{3 \times 3^2 + 4 \times 3 + 1} \right) = \frac{-10}{27+12+1} \left(-\frac{7}{42} a_0 \right)$$

$$= \frac{70}{1680} a_0 = \frac{7}{168} a_0 = \boxed{\frac{1}{24} a_0}$$

$$\text{so } y_2 = a_0 x^0 + a_1 x^1 + a_2 x^2 + a_3 x^3 + a_4 x^4 + \dots$$

$$= a_0 + a_0 x + \frac{a_0}{2} x^2 - \frac{1}{6} a_0 x^3 + \frac{1}{24} a_0 x^4 + \dots$$

$$y_2 = a_0 \left(1 - x + \frac{x^2}{2} - \frac{1}{6} x^3 + \frac{1}{24} x^4 - \dots \right)$$

So general solution is $y = Ay_1 + By_2$

$$y = Ax^{2/3} \left(1 - \frac{3}{5}x + \frac{9}{40}x^2 - \frac{27}{440}x^3 + \dots \right)$$

$$+ B \left(1 - x + \frac{x^2}{2} - \frac{1}{6}x^3 + \frac{1}{24}x^4 + \dots \right)$$

where A, B are constants found from initial conditions.

ch 12
12.5

show that $\frac{d}{dx} (x J_1(x)) = x J_0(x)$.

use power series expansion $J_p(x) = \sum_{n=0}^{\infty} \frac{(-1)^n}{\Gamma(n+1)\Gamma(n+p+1)} \left(\frac{x}{2}\right)^{2n+p}$

for $p=1$, $J_1(x) = \sum \frac{(-1)^n}{\Gamma(n+1)\Gamma(n+2)} \left(\frac{x}{2}\right)^{2n+1}$

so $\frac{d}{dx} (x J_1(x)) = \frac{d}{dx} \left(x \sum \frac{(-1)^n}{\Gamma(n+1)\Gamma(n+2)} \left(\frac{x}{2}\right)^{2n+1} \right)$

$= \frac{d}{dx} \left(\sum \frac{(-1)^n}{\Gamma(n+1)\Gamma(n+2)} x \left(\frac{x}{2}\right)^{2n+1} \right)$

$= \frac{d}{dx} \left(\sum \frac{(-1)^n}{\Gamma(n+1)\Gamma(n+2)} x^{(2n+2)} \left(\frac{1}{2}\right)^{2n+1} \right)$

$= \sum \frac{(-1)^n}{\Gamma(n+1)\Gamma(n+2)} (2n+2) x^{(2n+1)} \left(\frac{1}{2}\right)^{2n+1}$

$= \sum \frac{(-1)^n (2n+2)}{\Gamma(n+1)\Gamma(n+2)} \left(\frac{x}{2}\right)^{2n+1}$

but $\Gamma(n+2) = (n+1)\Gamma(n+1)$ from definition.

so $= \sum \frac{(-1)^n 2(n+1)}{\Gamma(n+1)\Gamma(n+1)(n+1)} \left(\frac{x}{2}\right)^{2n+1} = \sum \frac{(-1)^n 2}{\Gamma(n+1)\Gamma(n+1)} \left(\frac{x}{2}\right)^{2n}$

$= \sum \frac{(-1)^n}{\Gamma(n+1)\Gamma(n+1)} \left(\frac{x}{2}\right)^{2n} x \quad \text{--- (1)}$

but $x J_0(x)$ is just the above, because

$x J_0(x) = x \sum \frac{(-1)^n}{\Gamma(n+1)\Gamma(n+1)} \left(\frac{x}{2}\right)^{2n} \Rightarrow$ more x into the sum gives (1). QED

hence $\frac{d}{dx} (x J_1(x)) = x J_0(x)$

ch 12
12.6 show that $J_0(x) - J_2(x) = 2 \frac{d}{dx} J_1(x)$.

here I will write few terms of $J_0 - J_2$ and compare to few terms of $2 \frac{d}{dx} J_1$.

$$J_p = \sum \frac{(-1)^n}{\Gamma(n+1)\Gamma(n+p+1)} \left(\frac{x}{2}\right)^{2n+p}$$

$$J_0 = \sum \frac{(-1)^n}{\Gamma(n+1)\Gamma(n+1)} \left(\frac{x}{2}\right)^{2n}$$

$$J_1 = \sum \frac{(-1)^n}{\Gamma(n+1)\Gamma(n+2)} \left(\frac{x}{2}\right)^{2n+1}$$

$$J_2 = \sum \frac{(-1)^n}{\Gamma(n+1)\Gamma(n+3)} \left(\frac{x}{2}\right)^{2n+2}$$

$$\begin{aligned} J_0 - J_2 &= \left(\frac{1}{\Gamma(1)\Gamma(1)} - \frac{1}{\Gamma(2)\Gamma(2)} \left(\frac{x}{2}\right)^2 + \frac{1}{\Gamma(3)\Gamma(3)} \left(\frac{x}{2}\right)^4 - \dots \right) - \left(\frac{1}{\Gamma(1)\Gamma(3)} \left(\frac{x}{2}\right)^2 - \frac{1}{\Gamma(2)\Gamma(4)} \left(\frac{x}{2}\right)^4 + \dots \right) \\ &= \frac{1}{\Gamma(1)\Gamma(1)} + \left(\frac{x}{2}\right)^2 \left[-\frac{1}{\Gamma(2)\Gamma(2)} - \frac{1}{\Gamma(1)\Gamma(3)} \right] + \left(\frac{x}{2}\right)^4 \left[\frac{1}{\Gamma(3)\Gamma(3)} + \frac{1}{\Gamma(2)\Gamma(4)} \right] + \dots \end{aligned}$$

now $\Gamma(1) = \Gamma(2)$, $\Gamma(3) = 2\Gamma(2)$, $\Gamma(4) = 3\Gamma(3)$ so above becomes

$$\begin{aligned} J_0 - J_2 &= \frac{1}{\Gamma(1)\Gamma(1)} + \left(\frac{x}{2}\right)^2 \left[-\frac{1}{\Gamma(2)\Gamma(2)} - \frac{1}{2\Gamma(2)\Gamma(2)} \right] + \left(\frac{x}{2}\right)^4 \left[\frac{1}{\Gamma(3)\Gamma(3)} + \frac{1}{\frac{1}{2}\Gamma(3)3\Gamma(3)} \right] + \dots \\ &= 1 - \left(\frac{x}{2}\right)^2 \left[\frac{3}{2} \frac{1}{\Gamma(2)\Gamma(2)} \right] + \left(\frac{x}{2}\right)^4 \left[\frac{1}{\Gamma(3)\Gamma(3)} + \frac{2}{3} \frac{1}{\Gamma(3)\Gamma(3)} \right] \\ &= 1 - \left(\frac{x}{2}\right)^2 \left[\frac{3}{2} \frac{1}{\Gamma(2)\Gamma(2)} \right] + \left(\frac{x}{2}\right)^4 \left[\frac{5}{3} \frac{1}{\Gamma(3)\Gamma(3)} \right] + \dots \quad \text{--- (1)} \end{aligned}$$

now look at $2 \frac{d}{dx} J_1(x)$.

$$\begin{aligned} 2 \frac{d}{dx} J_1(x) &= 2 \frac{d}{dx} \left(\frac{1}{\Gamma(1)\Gamma(2)} \left(\frac{x}{2}\right) - \frac{1}{\Gamma(2)\Gamma(3)} \left(\frac{x}{2}\right)^3 + \frac{1}{\Gamma(3)\Gamma(4)} \left(\frac{x}{2}\right)^5 - \dots \right) \\ &= 2 \frac{d}{dx} \left(\frac{1}{\Gamma(1)\Gamma(2)} \frac{1}{2} x - \frac{1}{\Gamma(2)2\Gamma(2)} \left(\frac{1}{2}\right)^3 x^3 + \frac{1}{\Gamma(3)3\Gamma(3)} \left(\frac{1}{2}\right)^5 x^5 - \dots \right) \\ &= 2 \left(\frac{1}{2} \frac{1}{\Gamma(1)\Gamma(2)} - \frac{1}{2} \frac{1}{\Gamma(2)\Gamma(2)} \left(\frac{1}{2}\right)^3 3x^2 + \frac{1}{3} \frac{1}{\Gamma(3)\Gamma(3)} \left(\frac{1}{2}\right)^5 \cdot 5x^4 - \dots \right) \\ &= 1 - \frac{3}{\Gamma(2)\Gamma(2)} \left(\frac{1}{2}\right)^3 x^2 + \frac{5}{3} \frac{1}{\Gamma(3)\Gamma(3)} \left(\frac{1}{2}\right)^4 x^4 - \dots \\ &= 1 - \frac{3}{2} \frac{1}{\Gamma(2)\Gamma(2)} \left(\frac{x}{2}\right)^2 + \frac{5}{3} \frac{1}{\Gamma(3)\Gamma(3)} \left(\frac{x}{2}\right)^4 - \dots \quad \text{--- (2)} \end{aligned}$$

looking at (1) and (2), show they are the same, i.e. coefficient of x are equal in both sequences. hence

$$\boxed{2 \frac{d}{dx} J_1(x) = J_0 - J_2}$$

(9)

ch 12
12.8

show that $\lim_{x \rightarrow 0} x^{-3/2} J_{3/2}(x) = \frac{1}{3} \sqrt{\frac{2}{\pi}}$.

$$J_p = \sum \frac{(-1)^n}{\Gamma(n+1)\Gamma(n+p+1)} \left(\frac{x}{2}\right)^{2n+p}$$

$$J_{3/2} = \sum \frac{(-1)^n}{\Gamma(n+1)\Gamma(n+\frac{3}{2}+1)} \left(\frac{x}{2}\right)^{2n+3/2} = \left(\frac{x}{2}\right)^{3/2} \sum \frac{(-1)^n}{\Gamma(n+1)\Gamma(n+\frac{3}{2}+1)} \left(\frac{x}{2}\right)^{2n}$$

expand:

$$J_{3/2} = \left(\frac{x}{2}\right)^{3/2} \left(\frac{1}{\Gamma(1)\Gamma(\frac{3}{2}+1)} - \text{terms with } x \text{ in numerator. I don't care about since in the limit will be all removed} \right)$$

$$\lim_{x \rightarrow 0} \frac{1}{x^{3/2}} \frac{(x)^{3/2}}{(2)^{3/2}} \left(\frac{1}{\Gamma(1)\Gamma(\frac{3}{2}+1)} - \dots \right)$$

$$= \frac{1}{2^{3/2}} \left(\frac{1}{\Gamma(1)\Gamma(\frac{3}{2}+1)} \right) = \frac{1}{2^{3/2}} \left(\frac{1}{\Gamma(1)\frac{3}{2}\Gamma(\frac{3}{2})} \right)$$

$$= \frac{1}{2^{3/2}} \left(\frac{1}{\Gamma(1)\frac{3}{2} \times \frac{1}{2} \Gamma(\frac{1}{2})} \right) = \frac{1}{2^{3/2}} \left(\frac{1}{\frac{3}{2} \times \frac{1}{2} \times \sqrt{\pi}} \right)$$

$$= \frac{1}{2^{3/2}} \frac{2^2}{3} \frac{1}{\sqrt{\pi}} = \frac{1}{3} \frac{1}{\sqrt{\pi}} 2^{2-3/2} = \frac{1}{3} \frac{1}{\sqrt{\pi}} 2^{1/2} = \frac{1}{3} \sqrt{\frac{2}{\pi}}$$

here I used $\Gamma(p+1) = p\Gamma(p)$

ch 12

12.9

show that $\sqrt{\frac{\pi x}{2}} J_{(1/2)}^{(x)} = \sin x$

$$J_p = \sum \frac{(-1)^n}{\Gamma(n+1)\Gamma(n+p+1)} \left(\frac{x}{2}\right)^{2n+p}$$

$$J_{1/2} = \sum \frac{(-1)^n}{\Gamma(n+1)\Gamma(n+\frac{1}{2}+1)} \left(\frac{x}{2}\right)^{2n+\frac{1}{2}}$$

$$= \frac{1}{\Gamma(1)\Gamma(\frac{1}{2}+1)} \left(\frac{x}{2}\right)^{1/2} - \frac{1}{\Gamma(2)\Gamma(1\frac{1}{2}+1)} \left(\frac{x}{2}\right)^{3/2} + \frac{1}{\Gamma(3)\Gamma(2\frac{1}{2}+1)} \left(\frac{x}{2}\right)^{5/2} - \dots$$

but $\Gamma(p+1) = p\Gamma(p)$ and $\Gamma(\frac{1}{2}) = \sqrt{\pi}$

so write $\Gamma(\frac{1}{2}+1)$ as $\frac{1}{2}\Gamma(\frac{1}{2}) = \frac{1}{2}\sqrt{\pi}$

and $\Gamma(1\frac{1}{2}+1) = 1\frac{1}{2}\Gamma(1\frac{1}{2}) = \frac{3}{2} \times \frac{1}{2} \times \sqrt{\pi}$

and $\Gamma(2\frac{1}{2}+1) = 2\frac{1}{2}\Gamma(2\frac{1}{2}) = \frac{5}{2} \times \frac{3}{2} \times \frac{1}{2} \times \sqrt{\pi}$

$\Gamma(3\frac{1}{2}+1) = 3\frac{1}{2}\Gamma(3\frac{1}{2}) = \frac{7}{2} \times \frac{5}{2} \times \frac{3}{2} \times \frac{1}{2} \times \sqrt{\pi}$ etc...

$$\text{so } J_{1/2} = \frac{1}{\Gamma(1)\frac{1}{2}\sqrt{\pi}} \left(\frac{x}{2}\right)^{1/2} - \frac{1}{\Gamma(2)\frac{3}{2} \times \frac{1}{2} \times \sqrt{\pi}} \left(\frac{x}{2}\right)^{3/2} + \frac{1}{\Gamma(3)\frac{5}{2} \times \frac{3}{2} \times \frac{1}{2} \times \sqrt{\pi}} \left(\frac{x}{2}\right)^{5/2} - \dots$$

and $\Gamma(1) = 1$

$\Gamma(2) = 1$

$\Gamma(3) = 2!$

$\Gamma(4) = 3!$ etc...

$$\text{so } J_{1/2} = \frac{1}{\frac{1}{2}\sqrt{\pi}} \left(\frac{x}{2}\right)^{1/2} - \frac{1}{\frac{3}{2} \times \frac{1}{2} \times \sqrt{\pi}} \left(\frac{x}{2}\right)^{3/2} + \frac{1}{2! \times \frac{5}{2} \times \frac{3}{2} \times \frac{1}{2} \times \sqrt{\pi}} \left(\frac{x}{2}\right)^{5/2} - \frac{1}{3! \times \frac{7}{2} \times \frac{5}{2} \times \frac{3}{2} \times \frac{1}{2} \times \sqrt{\pi}} \left(\frac{x}{2}\right)^{7/2} + \dots$$

$$= \frac{1}{\sqrt{\pi}} \left(\frac{1}{2} \frac{x^{1/2}}{2^{1/2}} - \frac{x^{5/2}}{\frac{3}{2} \times \frac{1}{2} \times 2^{5/2}} + \frac{x^{9/2}}{2 \times \frac{5}{2} \times \frac{3}{2} \times \frac{1}{2} \times 2^{9/2}} - \frac{x^{13/2}}{(2 \times 3) \frac{7}{2} \times \frac{5}{2} \times \frac{3}{2} \times \frac{1}{2} \times 2^{13/2}} + \dots \right)$$

$$= \frac{1}{\sqrt{\pi}} \left(\frac{x^{1/2}}{2^{-1/2}} - \frac{x^{5/2}}{1 \times 3 \times 2^{-2} \times 2^{5/2}} + \frac{x^{9/2}}{2 \times 5 \times 3 \times 1 \times 2^{-3} \times 2^{9/2}} - \frac{x^{13/2}}{(2 \times 3) \times 7 \times 5 \times 3 \times 1 \times 2^{-4} \times 2^{13/2}} + \dots \right)$$

$$= \frac{1}{\sqrt{\pi}} \left(\frac{x^{1/2}}{2^{-1/2}} - \frac{x^{5/2}}{2^{1/2} \times 1 \times 3} + \frac{x^{9/2}}{2 \times 5 \times 3 \times 1 \times 2^{3/2}} - \frac{x^{13/2}}{(2 \times 3) \times 7 \times 5 \times 3 \times 1 \times 2^{5/2}} + \dots \right)$$

use this to get 4 factorial

use this to get 113 factorial

$$= \frac{1}{\sqrt{\pi}} \left(\frac{x^{\frac{1}{2}}}{2^{-\frac{1}{2}}} - \frac{x^{\frac{5}{2}}}{2^{\frac{1}{2}} \times 1 \times 2 \times 3} + \frac{x^{\frac{9}{2}}}{1 \times 2 \times 3 \times 4 \times 5 \times 2^{-\frac{1}{2}}} - \frac{x^{\frac{13}{2}}}{1 \times 2 \times 3 \times 4 \times 5 \times 6 \times 7 \times 2^{-\frac{3}{2}}} \right)$$

borrow
borrowed
borrow
borrow

ok, almost there.

now multiply $J_{1/2}$ by $\sqrt{\frac{\pi x}{2}}$

$$= \sqrt{\frac{\pi x}{2}} \times$$

$$= x - \frac{x^3}{3!} + \frac{x^5}{5!} - \frac{x^7}{7!} + \dots$$

$$= \sin x$$

QED

(12)

ch 12

13.1 Using eq 12.9 and 13.1, write out first few terms of

$J_0(x)$, $J_1(x)$, $J_{-1}(x)$, $J_2(x)$, $J_{-2}(x)$. Show that $J_{-1}(x) = -J_1(x)$ and $J_{-2}(x) = J_2(x)$.

$$(12.9) \quad J_p(x) = \sum \frac{(-1)^n}{\Gamma(n+1)\Gamma(n+p+1)} \left(\frac{x}{2}\right)^{2n+p}$$

$$(13.1) \quad J_{-p}(x) = \sum \frac{(-1)^n}{\Gamma(n+1)\Gamma(n-p+1)} \left(\frac{x}{2}\right)^{2n-p}$$

First few terms:

$$J_0(x) = \frac{1}{\Gamma(1)\Gamma(1)} - \frac{1}{\Gamma(2)\Gamma(2)} \left(\frac{x}{2}\right)^2 + \frac{1}{\Gamma(3)\Gamma(4)} \left(\frac{x}{2}\right)^4 - \frac{1}{\Gamma(4)\Gamma(5)} \left(\frac{x}{2}\right)^6 + \dots$$

$$J_1(x) = \frac{1}{\Gamma(1)\Gamma(2)} \left(\frac{x}{2}\right) - \frac{1}{\Gamma(2)\Gamma(3)} \left(\frac{x}{2}\right)^3 + \frac{1}{\Gamma(3)\Gamma(4)} \left(\frac{x}{2}\right)^5 - \frac{1}{\Gamma(4)\Gamma(5)} \left(\frac{x}{2}\right)^7 + \dots$$

$$J_{-1}(x) = \frac{1}{\Gamma(1)\Gamma(0)} \left(\frac{x}{2}\right)^{-1} - \frac{1}{\Gamma(2)\Gamma(1)} \left(\frac{x}{2}\right)^1 + \frac{1}{\Gamma(3)\Gamma(2)} \left(\frac{x}{2}\right)^3 - \frac{1}{\Gamma(4)\Gamma(3)} \left(\frac{x}{2}\right)^5 \dots$$

$$= 0 - \frac{1}{\Gamma(2)\Gamma(1)} \left(\frac{x}{2}\right) + \frac{1}{\Gamma(3)\Gamma(2)} \left(\frac{x}{2}\right)^3 - \frac{1}{\Gamma(4)\Gamma(3)} \left(\frac{x}{2}\right)^5 + \dots$$

$$J_2(x) = \frac{1}{\Gamma(1)\Gamma(3)} \left(\frac{x}{2}\right)^2 - \frac{1}{\Gamma(2)\Gamma(4)} \left(\frac{x}{2}\right)^4 + \frac{1}{\Gamma(3)\Gamma(5)} \left(\frac{x}{2}\right)^6 - \dots$$

$$J_{-2} = \frac{1}{\Gamma(1)\Gamma(-1)} \left(\frac{x}{2}\right)^{-2} - \frac{1}{\Gamma(2)\Gamma(0)} \left(\frac{x}{2}\right)^0 + \frac{1}{\Gamma(3)\Gamma(1)} \left(\frac{x}{2}\right)^2 - \dots$$

$$= 0 - 0 + \frac{1}{\Gamma(3)\Gamma(1)} \left(\frac{x}{2}\right)^2 - \dots$$

→

now need to show that $J_{-1}(x) = -J_1(x)$

From power series for $J_{-1}(x)$:

$$= -\frac{1}{0!x1!} \left(\frac{x}{2}\right) + \frac{1}{2!x1!} \left(\frac{x}{2}\right)^3 - \frac{1}{3!x2!} \left(\frac{x}{2}\right)^5 + \dots$$

and from power series for $J_1(x)$

$$= \frac{1}{0!x1!} \left(\frac{x}{2}\right) - \frac{1}{1!x2!} \left(\frac{x}{2}\right)^3 + \frac{1}{2!x3!} \left(\frac{x}{2}\right)^5 - \dots$$

so we see that $-J_1(x) = J_{-1}(x)$.

now show that $J_{-2}(x) = J_2(x)$.

power series for $J_{-2}(x) =$

$$\frac{1}{2!x0!} \left(\frac{x}{2}\right)^2 - \frac{1}{3!x1!} \left(\frac{x}{2}\right)^4 + \dots$$

while power series for $J_2(x) =$

$$\frac{1}{2!x0!} \left(\frac{x}{2}\right)^2 - \frac{1}{1!x3!} \left(\frac{x}{2}\right)^4 + \dots$$

which are the same.

(14)

ch 12

13.2

show that in general for integral n , $J_{-n} = (-1)^n J_n$ and $J_n(-x) = (-1)^n J_n$.(I'll use J_m, J_m instead since 'n' already used in the sum terms)

$$J_m(x) = \sum_{n=0}^{\infty} \frac{(-1)^n}{n! (n+m)!} \left(\frac{x}{2}\right)^{2n+m}$$

for m integer.

①

write out some terms:

$$J_m(x) = \frac{1}{m!} \left(\frac{x}{2}\right)^m - \frac{1}{(1+m)!} \left(\frac{x}{2}\right)^{2+m} + \frac{1}{(2+m)!} \left(\frac{x}{2}\right)^{3+m} - \dots$$

now if $m < 0$, then all negative factorials ^{terms} are zero, since $\Gamma(\text{negative integer}) = \infty$ and so $\frac{1}{\Gamma(n+m)} \rightarrow 0$ for $n+m < 0$ so $J_m(x)$ for negative m will have all its few terms when $(n+m) < 0$, as zero.so for negative m , we start sum from $n=m$

$$J_m = \sum_{n=m}^{\infty} \frac{(-1)^n}{\Gamma(n+1) \Gamma(n-m+1)} \left(\frac{x}{2}\right)^{2n-m}$$

let $n-m = k$, so when $n=m$, $k=0$, when $n=\infty$, $k=\infty$.

$$\text{so } J_{-m} = \sum_{k=0}^{\infty} \frac{(-1)^{k+m}}{\Gamma(k+m+1) \Gamma(k+1)} \left(\frac{x}{2}\right)^{2(k+m)-m}$$

$$J_{-m} = (-1)^m \sum_{k=0}^{\infty} \frac{(-1)^k}{\Gamma(k+1) \Gamma(k+m+1)} \left(\frac{x}{2}\right)^{2k+m}$$

but this is the same sum expression for $J_m(x)$ with k replacing n .

$$\text{so it can be written as } J_{-m} = (-1)^m \sum_{n=0}^{\infty} \frac{(-1)^n}{\Gamma(n+1) \Gamma(n+m+1)} \left(\frac{x}{2}\right)^{2n+m}$$

②

compare ① and ②, we see that

$$J_{-m}(x) = (-1)^m J_m(x)$$

Q.E.D.

13.5

$$N_{1/2} = \frac{\cos(\frac{\pi}{2}) J_{1/2} - J_{-1/2}}{\sin \frac{\pi}{2}} \quad \text{using eq 13.3 page 513}$$

$$\sin \frac{\pi}{2} = 1$$

$$\cos \frac{\pi}{2} = 0$$

$$\text{so } \boxed{N_{1/2} = -J_{1/2}}$$

Show that $N_{3/2} = J_{-3/2}$

$$N_{3/2} = \frac{\cos(\frac{3}{2}\pi) J_{3/2} - J_{-3/2}}{\sin(\frac{3}{2}\pi)}$$

$$\text{but } \sin(\frac{3}{2}\pi) = -\sin \frac{\pi}{2} = -1$$

$$\text{and } \cos(\frac{3}{2}\pi) = 1$$

$$\text{hence } \boxed{N_{3/2}(x) = +J_{-3/2}(x)}$$

ch 12

14.1

using Tables, sketch and find first 3 zeros for $J_0(x)$.
 from Table 9.1, page 390, handbook of math functions, by
 Abramowitz :

$J_0(x)$ changes signs at $x = 2.45, 5.55, 8.55$

From page 359 of same book :

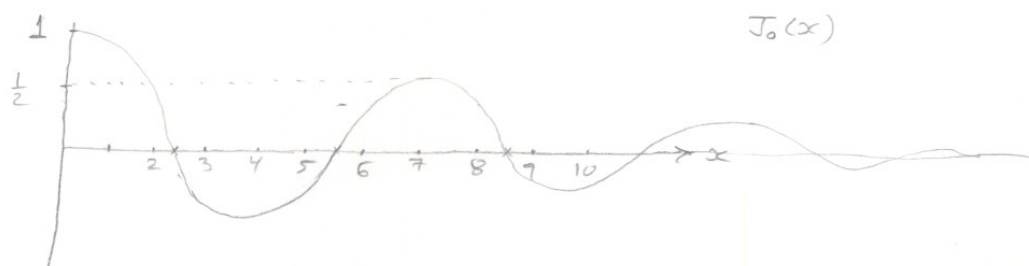

14.3 using Tables, sketch and find first 3 zeros of $N_0(x)$.

From same book, $N_0(x)$ Tables, (called $Y_0(x)$), are given on page 391.

From these Tables, I see $Y_0(x)$ change sign at

$x = 0.95, 3.85, 7.05$

Y_0 is very similar to J_0 , for $x > 2$. from page 359

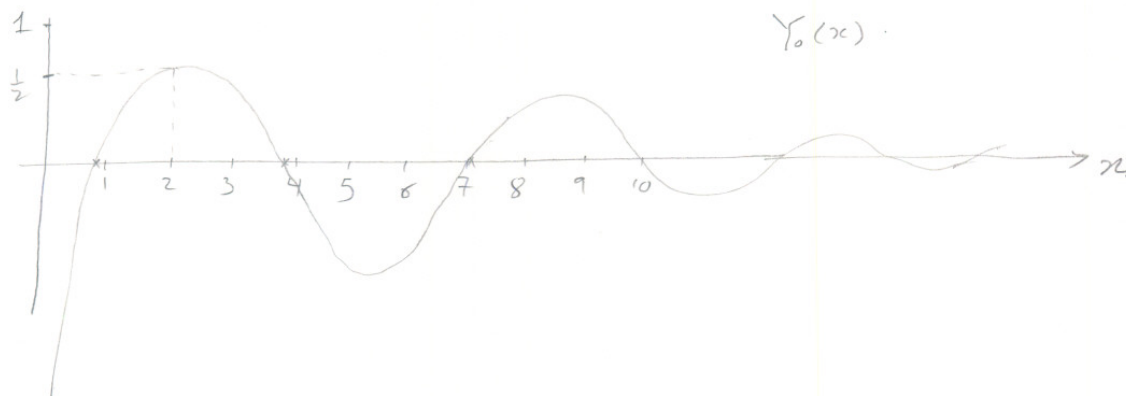

ch 12
 15.1 prove 15.2 by method similar to one used to prove 15.1.

15.2 is: $\frac{d}{dx} [x^{-p} J_p] = -x^{-p} J_{p+1}$

$$J_p = \sum \frac{(-1)^n}{\Gamma(n+1)\Gamma(n+p+1)} \left(\frac{x}{2}\right)^{2n+p}$$

$$J_{p+1} = \sum \frac{(-1)^n}{\Gamma(n+1)\Gamma(n+p+2)} \left(\frac{x}{2}\right)^{2n+p+1}$$

multiply by x^{-p} and differentiate

$$x^{-p} J_p = \sum \frac{(-1)^n}{\Gamma(n+1)\Gamma(n+p+1)} x^{2n} \frac{1}{2^{2n+p}}$$

$$\frac{d}{dx} [x^{-p} J_p] = \sum \frac{(-1)^n}{\Gamma(n+1)\Gamma(n+p+1)} (2n) x^{2n-1} \frac{1}{2^{2n+p}}$$

$\Gamma(n+1) = n\Gamma(n)$, so $\frac{d}{dx} [x^{-p} J_p] = \sum \frac{(-1)^n}{n\Gamma(n)\Gamma(n+p+1)} (2n) x^{2n-1} \frac{1}{2^{2n+p}} = \sum \frac{(-1)^n}{\Gamma(n)\Gamma(n+p+1)} \frac{x^{2n-1}}{2^{2n+p-1}}$

multiply by $\frac{1}{(x)^{-p}} \Rightarrow \frac{1}{(x)^p} \frac{d}{dx} [x^{-p} J_p] = \frac{1}{(x)^p} \sum \frac{(-1)^n}{\Gamma(n)\Gamma(n+p+1)} \frac{x^{2n-1}}{2^{2n+p-1}} = \sum \frac{(-1)^n}{\Gamma(n)\Gamma(n+p+1)} \frac{x^{2n+p-1}}{2^{2n+p-1}}$

$$\Rightarrow \frac{1}{(x)^p} \frac{d}{dx} [x^{-p} J_p] = - \sum \frac{(-1)^n}{\Gamma(n)\Gamma(n+p+1)} \left(\frac{x}{2}\right)^{2n+p-1} = \boxed{\sum \frac{(-1)^n n}{\Gamma(n+1)\Gamma(n+p+1)} \left(\frac{x}{2}\right)^{2n+p-1}}$$

let me look at few terms in J_{p+1} and in

to see pattern:

$$\sum \frac{(-1)^n n}{\Gamma(n+1)\Gamma(n+p+1)} \left(\frac{x}{2}\right)^{2n+p-1} = 0 - \frac{1}{\Gamma(2)\Gamma(p+2)} \left(\frac{x}{2}\right)^{p+1} + \frac{1 \times 2}{\Gamma(3)\Gamma(p+3)} \left(\frac{x}{2}\right)^{p+3} - \frac{1 \times 3}{\Gamma(4)\Gamma(p+4)} \left(\frac{x}{2}\right)^{p+5} + \dots$$

$$J_{p+1} = \frac{1}{\Gamma(1)\Gamma(p+2)} \left(\frac{x}{2}\right)^{p+1} - \frac{1}{\Gamma(2)\Gamma(p+3)} \left(\frac{x}{2}\right)^{p+3} + \frac{1}{\Gamma(3)\Gamma(p+4)} \left(\frac{x}{2}\right)^{p+5} + \dots$$

so if I rewrite (1) as

$$\sum \frac{(-1)^n n}{\Gamma(n+1)\Gamma(n+p+1)} \left(\frac{x}{2}\right)^{2n+p-1} = 0 - \frac{1}{1 \times \Gamma(1)\Gamma(p+2)} \left(\frac{x}{2}\right)^{p+1} + \frac{1 \times 2}{2 \Gamma(2)\Gamma(p+3)} \left(\frac{x}{2}\right)^{p+3} - \frac{1 \times 3}{3 \Gamma(3)\Gamma(p+4)} \left(\frac{x}{2}\right)^{p+5} + \dots$$

but $J_{p+1} = \frac{1}{\Gamma(1)\Gamma(p+2)} \left(\frac{x}{2}\right)^{p+1} - \frac{1}{\Gamma(2)\Gamma(p+3)} \left(\frac{x}{2}\right)^{p+3} + \frac{1}{\Gamma(3)\Gamma(p+4)} \left(\frac{x}{2}\right)^{p+5} + \dots$

so we see the sign shift!

i.e. $J_{p+1} = - \sum \frac{(-1)^n n}{\Gamma(n+1)\Gamma(n+p+1)} \left(\frac{x}{2}\right)^{2n+p-1} = - \frac{1}{x^{-p}} \frac{d}{dx} [x^{-p} J_p]$

Ch 12

15.2

solve 15.1 and 15.2 for J_{p+1} and J_{p-1} . Add and subtract these two equations to get 15.3 and 15.4.

$$(15.1) \quad \frac{d}{dx} (x^p J_p) = x^p J_{p-1}$$

$$(15.2) \quad \frac{d}{dx} (x^{-p} J_p) = -x^{-p} J_{p+1}$$

$$\text{From (15.1)} \quad J_{p-1} = x^{-p} \frac{d}{dx} (x^p J_p)$$

$$\text{From (15.2)} \quad J_{p+1} = -x^p \frac{d}{dx} (x^{-p} J_p)$$

$$\begin{aligned} \text{So } J_{p-1} + J_{p+1} &= x^{-p} \frac{d}{dx} (x^p J_p) - x^p \frac{d}{dx} (x^{-p} J_p) = x^{-p} [x^p J_p' + p x^{p-1} J_p] - x^p [x^{-p} J_p' + (-p)x^{-p-1} J_p] \\ &= x^{-p} x^p J_p' + x^{-p} p x^{p-1} J_p - x^p x^{-p} J_p' + p x^p x^{-p-1} J_p \\ &= J_p' + x^{-1} p J_p - J_p' + x^{-1} p J_p \\ &= x^{-1} p J_p + x^{-1} p J_p \end{aligned}$$

$$J_{p-1} + J_{p+1} = \boxed{2 \frac{p}{x} J_p} \quad \text{which is 15.3}$$

$$\begin{aligned} \text{now } J_{p-1} - J_{p+1} &= x^{-p} \frac{d}{dx} (x^p J_p) + x^p \frac{d}{dx} (x^{-p} J_p) \\ &= x^{-p} [x^p J_p' + p x^{p-1} J_p] + x^p [x^{-p} J_p' + (-p)x^{-p-1} J_p] \\ &= J_p' + p x^{-1} J_p + J_p' - p x^{-1} J_p \\ &= \boxed{2 J_p'(x)} \quad \text{which is 15.4.} \end{aligned}$$

ch 12

15.3 Carry out the differentiation in 15.1 and 15.2 to get 15.5

From (15.1) $\frac{d}{dx} [x^p J_p] = x^p J_{p-1}$

15.2 $\frac{d}{dx} [x^{-p} J_p] = -x^{-p} J_{p+1}$

differentiate 15.1 $\Rightarrow x^p J_p' + p x^{p-1} J_p = x^p J_{p-1}$

so $J_p' = \frac{x^p J_{p-1} - p x^{p-1} J_p}{x^p} = J_{p-1} - p x^{-1} J_p = \boxed{J_{p-1} - \frac{p}{x} J_p} \quad \text{--- (1)}$

differentiate 15.2 \Rightarrow

$$x^{-p} J_p' + (-p) x^{-p-1} J_p = -x^{-p} J_{p+1}$$

so $J_p' = \frac{-x^{-p} J_{p+1} + p x^{-p-1} J_p}{x^{-p}} = -J_{p+1} + p x^{-1} J_p$

$$= \boxed{-J_{p+1} + \frac{p}{x} J_p} \quad \text{--- (2)}$$

from (1) and (2) we see that

$$J_p' = J_{p-1} - \frac{p}{x} J_p = \frac{p}{x} J_p - J_{p+1}$$

which is 15.5

ch 12
 15.5 Using 15.4 and 15.5 show that $J_0 = J_2$ at every min or max of J_1 . and $J_0 = -J_2 = -J_1'$ at every position zero of J_1 . sketch J_0, J_1, J_2 on same axes.

(15.4): $J_{p-1} - J_{p+1} = 2J_p'$
 (15.5) $J_p' = -\frac{p}{x} J_p + J_{p-1} = \frac{p}{x} J_p - J_{p+1}$

$J_p^{(x)} = 0$ at min or max of J_p by definition.

From 15.4, set $p=1$ and $J_p' = 0$ we set
 $J_0 - J_2 = 0 \Rightarrow \boxed{J_0 = J_2}$ at each minmax of J_1

From (15.5), set $p=1$, we set

$J_1^{(x)} = -\frac{1}{x} J_1 + J_0$
 and $J_1^{(x)} = \frac{1}{x} J_1 - J_2$

so for $x > 0$, $J_1' = -\frac{J_1}{x} + J_0$ — (1)
 $J_1' = \frac{J_1}{x} - J_2$ — (2)

at a zero of $J_1(x)$, this means $J_1(x) = 0$ by definition.

i.e. $\textcircled{1}, \textcircled{2} \Rightarrow \left. \begin{matrix} J_1' = J_0 \\ J_1' = -J_2 \end{matrix} \right\}$ or $\boxed{J_0 = -J_2 = J_1'}$ at each zero of J_1

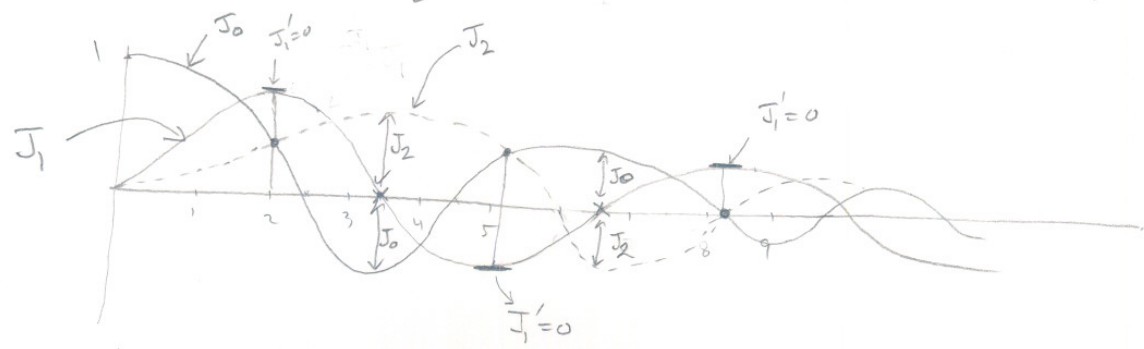

at each zero of J_1 , $J_0 = -J_1'$
 at $J_1' = 0$, $J_0 = J_2$

ch 12
15.7

using 15.2 show that $\int_0^{\infty} J_1(x) dx = -J_0(x) \Big|_0^{\infty} = 1$

$$(15.2) \quad \frac{d}{dx} [x^{-p} J_p] = -x^{-p} J_{p+1}(x).$$

$$\text{let } p=0 \Rightarrow \frac{d}{dx} [x^{-0} J_0] = -x^{-0} J_1$$

$$\text{or } \frac{d}{dx} (J_0) = -J_1$$

From Fundamental theorem of Calculus, $\frac{d}{dx} (f(x)) = g(x) \Rightarrow \int g(x) dx = f(x)$

$$\text{so } -\int_a^b J_1 dx = -\left[J_0 \Big|_b - J_0 \Big|_a \right]$$

$$\text{or } \int_a^b g(x) dx = f(x) \Big|_b - f(x) \Big|_a$$

$$\text{i.e. } \int_0^{\infty} J_1(x) dx = -\left[J_0 \Big|_0^{\infty} \right] = -\left[J_0(\infty) - J_0(0) \right]$$

$$\text{From } J_p = \sum \frac{(-1)^n}{\Gamma(n+1)\Gamma(n+p+1)} \left(\frac{x}{2}\right)^{2n+p}$$

$$\text{when } p=0, x=0 \text{ we set } \sum \frac{(-1)^n}{\Gamma(n+1)\Gamma(n+1)} \left(\frac{x}{2}\right)^{2n}$$

$$\text{so } J_0(x) = \frac{1}{\Gamma(1)\Gamma(1)} - \frac{1}{\Gamma(2)\Gamma(2)} \left(\frac{x}{2}\right)^2 + \dots = 1$$

when $p=0$, $J_0(\infty) = 0$

since graph of J_0

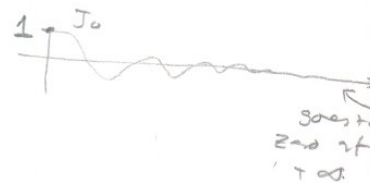

$$\int_0^{\infty} J_1(x) dx = -\left[J_0(\infty) - J_0(0) \right]$$

$$= -\left[0 - 1 \right] = \boxed{1}$$

4.6 HW 6



ch 12

16.3

Find solutions of following DE in terms of Bessel functions by using 16.1 and 16.2.

$$xy'' + 2y' + 4y = 0.$$

$$(16.1) \quad y'' + \frac{1-2a}{x} y' + \left[(bcx^{c-1})^2 + \frac{a^2 - p^2 c^2}{x^2} \right] y = 0$$

$$(16.2) \quad y = x^a Z_p(bx^c)$$

start by dividing DE by x to set it to 16.1 form:

$$y'' + \frac{2}{x} y' + 4\frac{y}{x} = 0$$

$$\text{Compare to 16.1} \Rightarrow 1-2a = 2 \Rightarrow 2a = -1 \Rightarrow \boxed{a = -\frac{1}{2}} \quad \text{--- ①}$$

$$a^2 - p^2 c^2 = 0 \Rightarrow \frac{1}{4} - p^2 c^2 = 0 \quad \text{--- ②}$$

$$\text{and } (bc)^2 (x^{c-1})^2 = \frac{4}{x}$$

$$\text{so } bc = 2 \quad \text{--- ③}$$

$$\text{and } x^{2c-2} = x^{-1} \Rightarrow 2c-2 = -1 \Rightarrow \boxed{c = \frac{1}{2}} \quad \text{--- ④}$$

$$\text{From ④ and ③} \Rightarrow b = \frac{2}{c} = \frac{2}{\frac{1}{2}} = 4 \quad \text{i.e. } \boxed{b=4}$$

$$\text{From ④ and ②} \Rightarrow \frac{1}{4} - p^2 \left(\frac{1}{4}\right) = 0 \Rightarrow 1 = p^2 \quad \text{i.e. } \boxed{p=1}$$

$$\text{So solution } y = x^{-\frac{1}{2}} \sum_1 (4x^{\frac{1}{2}})$$

$$\boxed{y = \frac{1}{\sqrt{x}} \sum_1 (4\sqrt{x})}$$

$$\text{i.e. general solution } y = \frac{1}{\sqrt{x}} \left[A J_1(4\sqrt{x}) + B N_1(4\sqrt{x}) \right]$$

where A, B are arbitrary constants.

where J_1 is Bessel function order 1.

$$N_p(x) \text{ is } \frac{\cos(\pi p) J_p(x) - J_{-p}(x)}{\sin \pi p} \quad (\text{eq. 13.3 in text})$$

used mathematica to plot the solution for $A=1, B=1$.

please see next.

```
Plot[ $\frac{\text{BesselJ}[1, 4 \sqrt{x}]}{\sqrt{x}} + \frac{\text{BesselY}[1, 4 \sqrt{x}]}{\sqrt{x}}$ , {x, 0, 10}]
```

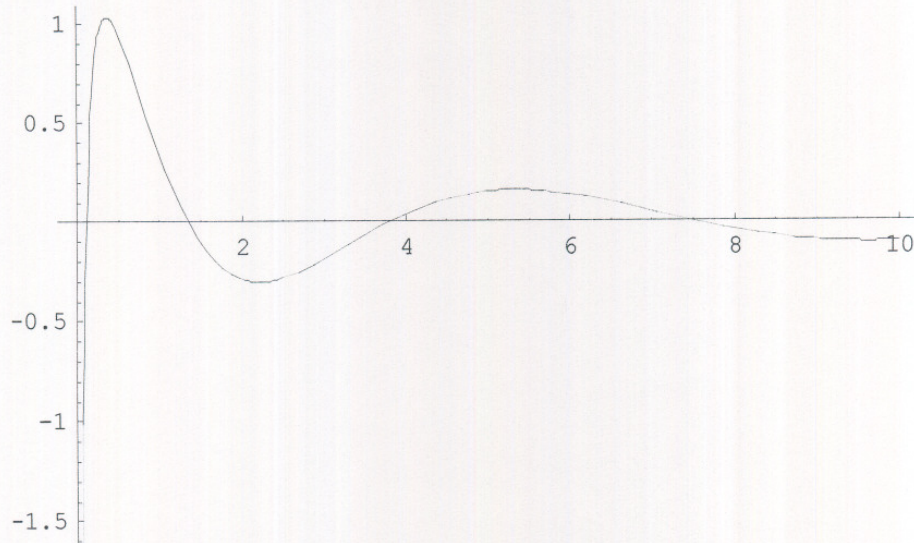

```
Plot[ $\frac{\text{BesselJ}[1, 4 \sqrt{x}]}{\sqrt{x}} + \frac{\text{BesselY}[1, 4 \sqrt{x}]}{\sqrt{x}}$ , {x, 0, 50}]
```

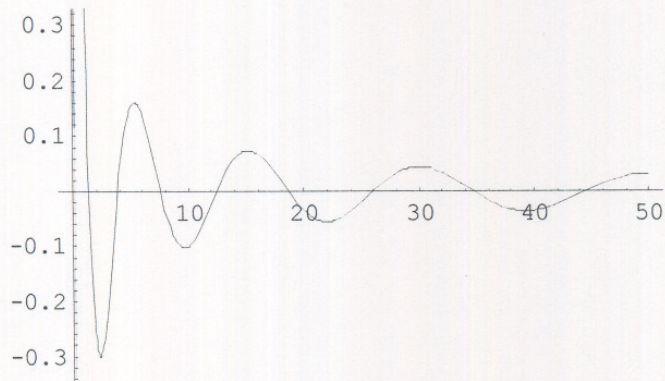

-Graphics-

Ch 12

17.2 From problem 12.9, $J_{1/2} = \sqrt{\frac{2}{\pi x}} \sin x$. Use (15.2) to obtain $J_{3/2}(x)$ and $J_{5/2}(x)$. substitute your result for the J 's into 17.4. to verify the formulas stated for J_0, J_1, J_2 in terms of $\sin x$ and $\cos x$.

$$15.2 \text{ is } \frac{d}{dx} [x^{-p} J_p(x)] = -x^{-p} J_{p+1}(x)$$

$$17.4 \text{ for } J_n(x) = \sqrt{\frac{\pi}{2x}} J_{\frac{(2n+1)}{2}} = x^n \left(-\frac{1}{x} \frac{d}{dx} \right)^n \left(\frac{\sin x}{x} \right)$$

$$\text{since } J_{1/2} = \sqrt{\frac{2}{\pi x}} \sin x, \text{ Then using 15.2 } \boxed{J_{p+1} = -\frac{d}{dx} [x^{-p} J_p] \frac{1}{x^{-p}}}$$

$$\text{let } p = \frac{1}{2} \Rightarrow J_{3/2} = -\frac{d}{dx} \left[x^{-1/2} J_{1/2} \right] \frac{1}{x^{-1/2}}$$

$$\text{i.e. } J_{3/2} = -\frac{d}{dx} \left[x^{-1/2} \sqrt{\frac{2}{\pi x}} \sin x \right] \sqrt{x}$$

$$= -\sqrt{x} \frac{d}{dx} \left[\frac{1}{\sqrt{x}} \sqrt{\frac{2}{\pi x}} \sin x \right] = -\sqrt{x} \frac{d}{dx} \left[\frac{1}{x} \sqrt{\frac{2}{\pi}} \sin x \right] = -\sqrt{\frac{2x}{\pi}} \frac{d}{dx} [x^{-1} \sin x]$$

apply product rule of differentiation

$$J_{3/2} = -\sqrt{\frac{2x}{\pi}} \left[x^{-1} \cos x + (-1)x^{-2} \sin x \right] = -\sqrt{\frac{2x}{\pi}} \left[\frac{\cos x}{x} - \frac{\sin x}{x^2} \right]$$

$$\text{i.e. } \boxed{J_{3/2} = -\sqrt{\frac{2x}{\pi}} \left[\frac{\cos x}{x} - \frac{\sin x}{x^2} \right]}$$

to find $J_{5/2}$, let $p = 3/2$ and apply 15.2 again.

$$\text{i.e. } J_{p+1} = -x^p \frac{d}{dx} [x^{-p} J_p]$$

$$\text{or } J_{5/2} = -x^{3/2} \frac{d}{dx} \left[x^{-3/2} J_{3/2} \right] = -x^{3/2} \frac{d}{dx} \left[x^{-3/2} \left(-\sqrt{\frac{2x}{\pi}} \left(\frac{\cos x}{x} - \frac{\sin x}{x^2} \right) \right) \right]$$

$$J_{5/2} = +x^{3/2} \frac{d}{dx} \left[x^{-3/2} x^{1/2} \sqrt{\frac{2}{\pi}} \left(\frac{\cos x}{x} - \frac{\sin x}{x^2} \right) \right] = x^{3/2} \frac{d}{dx} \left[x^{-1} \sqrt{\frac{2}{\pi}} \left(\frac{\cos x}{x} - \frac{\sin x}{x^2} \right) \right]$$

$$= x^{3/2} \sqrt{\frac{2}{\pi}} \frac{d}{dx} \left[\frac{1}{x} \left(\frac{\cos x}{x} - \frac{\sin x}{x^2} \right) \right] = x \sqrt{\frac{2x}{\pi}} \frac{d}{dx} \left(\frac{\cos x}{x^2} - \frac{\sin x}{x^3} \right)$$

$$= x \sqrt{\frac{2x}{\pi}} \left(\frac{1}{x^2} (-\sin x) + \cos x (-2x^{-3}) - \left[\frac{1}{x^3} \cos x + \sin x (-3x^{-4}) \right] \right)$$

$$= x \sqrt{\frac{2x}{\pi}} \left(-\frac{\sin x}{x^2} - \frac{2 \cos x}{x^3} - \frac{\cos x}{x^3} + \frac{3 \sin x}{x^4} \right) \longrightarrow$$

$$\underline{n=0} \quad j_0 = \sqrt{\frac{\pi}{2x}} J_{\frac{(2n+1)}{2}} = \sqrt{\frac{\pi}{2x}} J_{1/2} = \sqrt{\frac{\pi}{2x}} \sqrt{\frac{2}{\pi x}} \sin x = \sqrt{\frac{2\pi}{2\pi x^2}} \sin x = \boxed{\frac{1}{x} \sin x}$$

using $j_n = x^n \left(-\frac{1}{x} \frac{d}{dx}\right)^n \left(\frac{\sin x}{x}\right)$ we set for $n=0$

$$j_0 = x^0 \left(-\frac{1}{x} \frac{d}{dx}\right)^0 \left(\frac{\sin x}{x}\right) = \boxed{\frac{\sin x}{x}} \quad \text{which matches}$$

so $\boxed{\text{ok for } n=0}$

$$\underline{n=1} \quad j_1 = \sqrt{\frac{\pi}{2x}} J_{\frac{(2n+1)}{2}} = \sqrt{\frac{\pi}{2x}} J_{3/2} = \sqrt{\frac{\pi}{2x}} \left(-\sqrt{\frac{2x}{\pi}} \left[\frac{\cos x}{x} - \frac{\sin x}{x^2}\right]\right)$$

$$= -\sqrt{\frac{2\pi x}{2x\pi}} \left(\frac{\cos x}{x} - \frac{\sin x}{x^2}\right) = \boxed{-\frac{\cos x}{x} + \frac{\sin x}{x^2}}$$

from derivative formula for j_n , we set

$$j_1 = x^1 \left(-\frac{1}{x} \frac{d}{dx}\right)^1 \left(\frac{\sin x}{x}\right) = x^1 \left(-\frac{1}{x} \left(\frac{1}{x} \cos x + \sin x (-1)x^{-2}\right)\right)$$

$$= x \left(-\frac{1}{x} \left(\frac{\cos x}{x} - \frac{\sin x}{x^2}\right)\right) = \boxed{-\frac{\cos x}{x} + \frac{\sin x}{x^2}} \quad \text{which matches}$$

so $\boxed{\text{ok for } n=1}$

$$\underline{n=2} \quad j_2 = \sqrt{\frac{\pi}{2x}} J_{\frac{(2n+1)}{2}} = \sqrt{\frac{\pi}{2x}} J_{5/2} = \sqrt{\frac{\pi}{2x}} x \sqrt{\frac{2x}{\pi}} \left(3 \frac{\sin x}{x^4} - \frac{\sin x}{x^2} - \frac{3 \cos x}{x^3}\right)$$

$$= x \sqrt{\frac{\pi 2x}{2x\pi}} \left(3 \frac{\sin x}{x^4} - \frac{\sin x}{x^2} - \frac{3 \cos x}{x^3}\right) = \boxed{3 \frac{\sin x}{x^3} - \frac{\sin x}{x} - \frac{3 \cos x}{x^2}}$$

from derivative formula for j_n , we set

$$j_2 = x^2 \left(-\frac{1}{x} \frac{d}{dx}\right)^2 \left(\frac{\sin x}{x}\right) = x^2 \left(-\frac{1}{x} \frac{d}{dx} \left(-\frac{1}{x} \frac{d}{dx} \left(\frac{\sin x}{x}\right)\right)\right)$$

$$= x^2 \left(-\frac{1}{x} \frac{d}{dx}\right) \left(-\frac{1}{x} \left[\frac{1}{x} \cos x + \sin x (-1)x^{-2}\right]\right)$$

$$= x^2 \left(-\frac{1}{x} \frac{d}{dx}\right) \left(-\frac{\cos x}{x^2} + \frac{\sin x}{x^3}\right) = x^2 \left(-\frac{1}{x} \left[-\frac{1}{x^2} (\sin x) - \cos x (-2)x^{-3} + \frac{1}{x^3} \cos x + \sin x \frac{(-3)}{x^4}\right]\right)$$

$$= -x \left[\frac{\sin x}{x^2} + \frac{3 \cos x}{x^3} - \frac{3 \sin x}{x^4}\right] = \boxed{-\frac{\sin x}{x} - \frac{3 \cos x}{x^2} + \frac{3 \sin x}{x^3}} \quad \text{which matches above answer also. QED}$$

Ch 12
 17.5 show from 17.4 that $h_n^{(1)}(x) = -i x^n \left(-\frac{1}{x} \frac{d}{dx}\right)^n \left(\frac{e^{ix}}{x}\right)$.

$$17.4: h_n^{(1)} = j_n(x) + i y_n(x)$$

$$\text{where } y_n(x) = -x^n \left(-\frac{1}{x} \frac{d}{dx}\right)^n \left(\frac{\cos x}{x}\right)$$

$$\text{from 17.4: } h_n^{(1)} = j_n(x) + i y_n(x)$$

$$\text{replace } j_n(x) \text{ by } x^n \left(-\frac{1}{x} \frac{d}{dx}\right)^n \left(\frac{\sin x}{x}\right)$$

$$\text{and } y_n(x) \text{ by } -x^n \left(-\frac{1}{x} \frac{d}{dx}\right)^n \left(\frac{\cos x}{x}\right)$$

$$\text{so 17.4 becomes: } h_n^{(1)} = x^n \left(-\frac{1}{x} \frac{d}{dx}\right)^n \left(\frac{\sin x}{x}\right) - i x^n \left(-\frac{1}{x} \frac{d}{dx}\right)^n \left(\frac{\cos x}{x}\right)$$

$$h_n^{(1)} = x^n \left(-\frac{1}{x} \frac{d}{dx}\right)^n \left[\frac{\sin x}{x} - i \frac{\cos x}{x} \right] = x^n \left(-\frac{1}{x} \frac{d}{dx}\right)^n \left[\left(\frac{x}{i}\right) \left(\frac{\sin x}{x} - i \frac{\cos x}{x}\right) \right]$$

$$= x^n \left(-\frac{1}{x} \frac{d}{dx}\right)^n \left[\frac{1}{i} \left(i \frac{\sin x}{x} - i^2 \frac{\cos x}{x} \right) \right] = x^n \left(-\frac{1}{x} \frac{d}{dx}\right)^n \left[\frac{1}{i} \left(\frac{\cos x}{x} + i \frac{\sin x}{x} \right) \right]$$

$$\text{but } e^{ix} = \cos x + i \sin x$$

$$\text{so } h_n^{(1)} = x^n \left(-\frac{1}{x} \frac{d}{dx}\right)^n \left[\frac{1}{i} \frac{e^{ix}}{x} \right] \quad \checkmark, \text{ but } \frac{1}{i} = -i \text{ so}$$

$$h_n^{(1)} = -i x^n \left(-\frac{1}{x} \frac{d}{dx}\right)^n \left[\frac{e^{ix}}{x} \right]$$

Ch 12
 17.7 solve $xy'' = y$ using 16.1 and then express answer in terms of a function I_p by 17.3.

16.1: says that $y'' + \frac{1-2a}{x} y' + \left[(bcx^{c-1})^2 + \frac{a^2 - p^2 c^2}{x^2} \right] y = 0$
 has solution $y = x^a Z_p (bx^c)$.

17.3: $I_p(x) = i^{-p} J_p(ix)$.

first solve $xy'' = y$.

$$\Rightarrow y'' - \frac{y}{x} = 0$$

compare to 16.1

$$1-2a=0 \quad \text{i.e.} \quad 2a=1 \quad \text{or} \quad \boxed{a=\frac{1}{2}}$$

$$-(a^2 - p^2 c^2) = 0 \quad \text{i.e.} \quad \boxed{p^2 c^2 = \frac{1}{4}} \quad \text{--- ①}$$

$$\text{and } bc^2 x^{2c-2} = -x^{-1} \Rightarrow bc^2 = -1$$

$$\text{and } 2c-2 = -1 \quad \text{i.e.} \quad 2c=1 \quad \text{i.e.} \quad \boxed{c=\frac{1}{2}} \quad \text{--- ②}$$

$$\text{then } b^2 \left(\frac{1}{4}\right) = -1 \quad \text{i.e.} \quad b^2 = -4 \quad \text{i.e.} \quad \boxed{b = \pm\sqrt{-4} \text{ or } \pm 2i}$$

$$\text{from ① and ②} \Rightarrow p^2 \left(\frac{1}{4}\right) = \frac{1}{4} \quad \text{i.e.} \quad \boxed{p=1}$$

So solution is $y = x^a Z_p b x^c$

$$= \sqrt{x} Z_p (\pm 2i) \sqrt{x}$$

i.e. $\boxed{y = \sqrt{x} Z_1(2i\sqrt{x}) \text{ or } y = \sqrt{x} Z_1(-2i\sqrt{x})}$

if I just take the positive root of b , i.e. $b = 2i$, then general solution is

$$\boxed{y = \sqrt{x} [A J_1(2i\sqrt{x}) + B N_1(2i\sqrt{x})]}$$

$$\text{or } y = \sqrt{x} [A J_1(2i\sqrt{x}) + B (\cos(\pi) J_1(2i\sqrt{x}) - \sin(\pi) J_{-1}(2i\sqrt{x}))] \quad \text{--- ③}$$

note: because of \cos expression,
 I'll leave y in terms of J and N and continue from there:

$$\text{so } y = \sqrt{x} \left[A J_1(2i\sqrt{x}) + B N_1(2i\sqrt{x}) \right]$$

$$\text{but } J_p(ix) = \frac{I_p(x)}{i^{-p}}$$

$$\text{so } J_1(i2\sqrt{x}) = \frac{I_1(2\sqrt{x})}{i^{-1}} = \boxed{-i I_1(2\sqrt{x})}$$

$$\text{and } J_{-1}(2i\sqrt{x}) = \frac{I_{-1}(2\sqrt{x})}{i} = -i I_{-1}(2\sqrt{x})$$

$$\text{so } \boxed{y = \sqrt{x} \left[A i I_1(2\sqrt{x}) + B N_1(2i\sqrt{x}) \right]}$$

to expand $N(x)$ in terms of J_p using eq. 13.3, I get $\sin \pi$ in denominator. for $x \neq 0$ this has a limit according to book.

So I'll show this as well:

$$y = \sqrt{x} \left[A i I_1(2\sqrt{x}) + B \left(\frac{\cos \pi J_1(2i\sqrt{x}) - J_{-1}(2i\sqrt{x})}{\sin \pi} \right) \right]$$

$$y = \sqrt{x} \left[A i I_1(2\sqrt{x}) + B \left(\frac{\cos \pi i I_1(2\sqrt{x}) + i I_{-1}(2\sqrt{x})}{\sin \pi} \right) \right]$$

$$\boxed{y = i\sqrt{x} \left[A I_1(2\sqrt{x}) + B \left(\frac{\cos \pi I_1(2\sqrt{x}) + I_{-1}(2\sqrt{x})}{\sin \pi} \right) \right]}$$

↗ this is general solution in terms of I_p but with indeterminate form for second term. this is valid for $x \neq 0$.

ch 12

17.10

Using Tables, sketch graph of the hyperbolic

Bessel function $I_0(x)$.

from Table 9.11, page 428, Handbook of math functions, Abramowitz,
these are values for $I_0(x)$.

x	$I_0(x)$
1	1.26606
2	2.79
5	27.2
10	2815.7
50	too large.

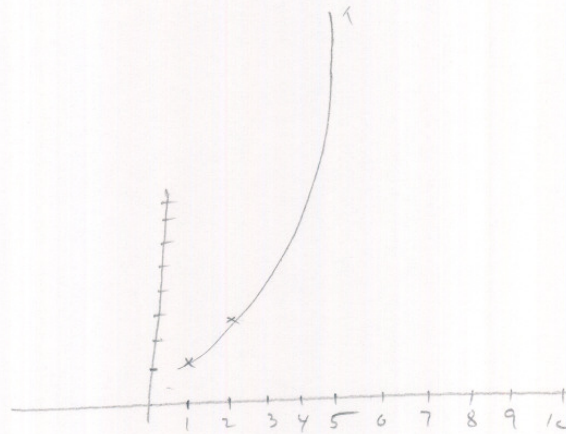

I now used *mma* to plot $I_0(x)$:



```
Plot[BesselI[0,x],{x,0,5} ]
```

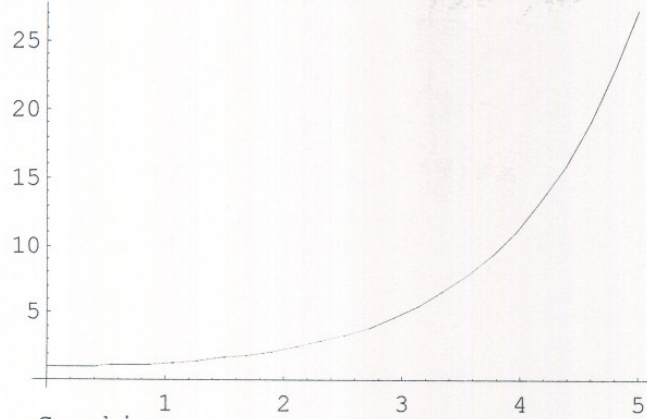

```
-Graphics-
```

```
Plot[BesselI[0,x],{x,0,10} ]
```

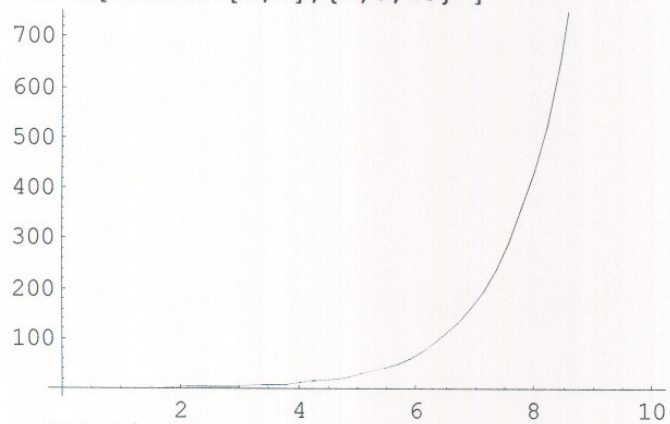

```
-Graphics-
```

ch 12

17.12

use section 15 recursion relations and 17.4 to obtain the following recursion relations for spherical Bessel functions:

$$j_{n-1}(x) + j_{n+1}(x) = (2n+1)j_n(x)/x$$

looking at 15.3 which says

$$J_{n-1}(x) + J_{n+1}(x) = \frac{2n}{x} J_n(x)$$

and using (17.4): $j_n(x) = \sqrt{\frac{\pi}{2x}} J_{\frac{2n+1}{2}}(x)$

so from 17.4, find J_{p-1} and J_{p+1} and J_p and sub into 17.4.

so from 17.4, $J_{\frac{2n+1}{2}} = \sqrt{\frac{2x}{\pi}} j_n(x)$

or $J_{n+\frac{1}{2}} = \sqrt{\frac{2x}{\pi}} j_n$

let $n+\frac{1}{2} = m$.

so $J_m = \sqrt{\frac{2x}{\pi}} j_{m-\frac{1}{2}}$

and $J_{m-1} = \sqrt{\frac{2x}{\pi}} j_{m-\frac{3}{2}}$

and $J_{m+1} = \sqrt{\frac{2x}{\pi}} j_{m+\frac{1}{2}}$

plug into 15.3 \Rightarrow

$$\sqrt{\frac{2x}{\pi}} j_{m-\frac{3}{2}} + \sqrt{\frac{2x}{\pi}} j_{m+\frac{1}{2}} = \frac{2(m-\frac{1}{2})}{x} \sqrt{\frac{2x}{\pi}} j_{m-\frac{1}{2}}$$

now we want to go back to 'n'. so let $m-\frac{3}{2} = n-1 \Rightarrow m+\frac{1}{2} = n+1$
 $\Rightarrow m-\frac{1}{2} = n$

$$\Rightarrow \sqrt{\frac{2x}{\pi}} j_{n-1} + \sqrt{\frac{2x}{\pi}} j_{n+1} = \frac{2}{x} (n-1+1) \sqrt{\frac{2x}{\pi}} j_n$$

or $j_{n-1} + j_{n+1} = \frac{2n}{x} j_n$ QED.

Ch 12

19.1

Prove equation 19.10 in following way. First note that 19.2 and 19.3 and therefore 19.7 hold whether a and b are zeros of $J_p(x)$ or not. Let a be zero but let b be just any number. From 19.7 show that

$$\int_0^1 xuv \, dx = \frac{J_p(b) a J_p'(a)}{b^2 - a^2}$$

now let $b \rightarrow a$ and evaluate using L'Hopital rule. here find

$$\int_0^1 xuv \, dx = \frac{1}{2} J_p'^2(a) \text{ for } a=b.$$

Solution

starting from equation 19.7 in book (page 523)

$$(v x u' - u x v') \Big|_0^1 + (a^2 - b^2) \int_0^1 xuv \, dx = 0$$

here

$$\begin{cases} u = J_p(ax) \\ v = J_p(bx) \end{cases}$$

we are given that a is a zero of $J_p(x)$ but b is not.

then the above becomes

$$J_p(bx) x J_p'(ax) - J_p(ax) x J_p'(bx) \Big|_0^1 + (a^2 - b^2) \int_0^1 x J_p(ax) J_p(bx) \, dx = 0$$

$$\left[J_p(b) (1) (a) J_p'(a) - \overset{=0 \text{ since } a \text{ is zero of } J_p}{J_p(a) \times 1 \times b \times J_p'(b)} - [0] + (a^2 - b^2) \int_0^1 x J_p(ax) J_p(bx) \, dx = 0 \right]$$

$$\text{so } \int_0^1 x J_p(ax) J_p(bx) \, dx = \frac{J_p(b) a J_p'(a)}{b^2 - a^2}$$

follows from above by rearranging.

for $b=a$, $J_p(bx) = J_p(ax)$, so LHS in above becomes

$$\int_0^1 x J_p^2(ax) \, dx, \text{ For RHS, use L'Hopital rule } \rightarrow$$

$$\lim_{b \rightarrow a} \frac{J_p(b) - J_p(a)}{b^2 - a^2} = \lim_{b \rightarrow a} \frac{\frac{d}{db} (J_p(b) - J_p(a))}{\frac{d}{db} (b^2 - a^2)}$$

$$= \lim_{b \rightarrow a} \frac{J_p'(b) - J_p'(a)}{2b} = \frac{J_p'(a) - J_p'(a)}{2a} = \frac{1}{2} (J_p'(a))^2$$

$$\text{so } \int_0^1 x J_p^2(ax) dx = \frac{1}{2} (J_p'(a))^2$$

now I need to show that LHS also results in $\frac{1}{2} J_{p-1}^2(a)$.

From 15.5

$$J_p'(x) = -\frac{p}{x} J_p(x) + J_{p-1}(x)$$

From 15.5

$$\text{so } J_p'(a) = -\frac{p}{a} J_p(a) + J_{p-1}(a)$$

then

$$\text{so } (J_p'(a))^2 = (J_{p-1}(a))^2$$

, but 'a' is a zero of $J_p(x)$, so $J_p(a) = 0$

$$\text{i.e. } \frac{1}{2} (J_p'(a))^2 = \frac{1}{2} J_{p-1}^2(a) \text{ which is what is required to show.}$$

now need to prove last form, the $\frac{1}{2} J_{p+1}^2(a)$.

From

$$\text{From 15.5, } J_p'(x) = \frac{p}{x} J_p(x) - J_{p+1}(x)$$

$$\text{so } J_p'(a) = \frac{p}{a} J_p(a) - J_{p+1}(a)$$

$\leftarrow = 0$

$$\text{so } J_p'(a) = -J_{p+1}(a)$$

$$(J_p'(a))^2 = J_{p+1}^2(a)$$

$$\text{so } \frac{1}{2} (J_p'(a))^2 = \frac{1}{2} J_{p+1}^2(a)$$

QED

Ch 12

$$\boxed{19.2} \quad \text{given } J_{3/2}(x) = \sqrt{\frac{2}{\pi x}} \left(\frac{\sin x}{x} - \cos x \right)$$

$$\text{use 19.10 to evaluate } \int_0^1 \left(\frac{\sin \alpha x}{\alpha x} - \cos \alpha x \right)^2 dx$$

assume β is a root of J_p i.e. $J_p(\beta) = 0$.

hence now I can use 19.10 (which can only be used if β is root).

i.e. I can write

$$\int_0^1 x J_p(\beta x) J_p(\beta x) dx = \frac{1}{2} J_p'^2(\beta)$$

now use the fact that $J_{3/2}(x) = \sqrt{\frac{2}{\pi x}} \left(\frac{\sin x}{x} - \cos x \right)$, then above becomes (for $p=3/2$)

$$\int_0^1 x \left[\sqrt{\frac{2}{\pi \beta x}} \left(\frac{\sin \beta x}{\beta x} - \cos \beta x \right) \right]^2 dx = \frac{1}{2} J_{3/2}'^2(\beta)$$

$$\frac{2}{\pi \beta} \int_0^1 \left(\frac{\sin \beta x}{\beta x} - \cos \beta x \right)^2 dx = \frac{1}{2} J_{3/2}'^2(\beta)$$

$$\int_0^1 \left(\frac{\sin \beta x}{\beta x} - \cos \beta x \right)^2 dx = \frac{\beta \pi}{4} J_{3/2}'^2(\beta)$$

where β is zero of $J_{3/2}(x)$.

before I use the fact from 'a' being root of $\tan x = x$,

let me calculate RHS of above equation



$$J'_{3/2}(\beta) = \frac{d}{dx} \sqrt{\frac{2}{\pi x}} \left(\frac{\sin x}{x} - \cos x \right) \Big|_{x=\beta}$$

$$= \sqrt{\frac{2}{\pi}} \left[\left(\frac{1}{\sqrt{x}} \left[\frac{1}{x} \cos x + \sin x \left(-\frac{1}{x^2} \right) - (-\sin x) \right] + \left(\frac{\sin x}{x} - \cos x \right) \left(-\frac{1}{2} \frac{1}{x^{3/2}} \right) \right) \right] \Big|_{x=\beta}$$

$$J'_{3/2}(\beta) = \sqrt{\frac{2}{\pi}} \left[\frac{1}{\sqrt{\beta}} \left(\frac{\cos \beta}{\beta} - \frac{\sin \beta}{\beta^2} + \sin \beta \right) + \left(\frac{\sin \beta}{\beta} - \cos \beta \right) \left(-\frac{1}{2\beta^{3/2}} \right) \right]$$

$$= \sqrt{\frac{2}{\pi}} \left[\frac{\cos(\beta)}{\beta^{3/2}} - \frac{\sin \beta}{\beta^{5/2}} + \frac{\sin \beta}{\beta^{1/2}} - \frac{\sin \beta}{2\beta^{5/2}} + \frac{\cos \beta}{2\beta^{3/2}} \right]$$

$$J'_{3/2}(\beta) = \sqrt{\frac{2}{\pi}} \left[\frac{3}{2} \frac{\cos \beta}{\beta^{3/2}} - \frac{3}{2} \frac{\sin \beta}{\beta^{5/2}} + \frac{\sin \beta}{\beta^{1/2}} \right]$$

$$J'^2_{3/2}(\beta) = \frac{2}{\pi} \left[\frac{3}{2} \frac{\cos \beta}{\beta^{3/2}} - \frac{3}{2} \frac{\sin \beta}{\beta^{5/2}} + \frac{\sin \beta}{\beta^{1/2}} \right]^2$$

$$= \frac{2}{\pi} \left[\frac{9}{4} \frac{\cos^2 \beta}{\beta^3} + \left(\frac{\sin \beta}{\beta^{1/2}} - \frac{3}{2} \frac{\sin \beta}{\beta^{5/2}} \right)^2 + 2 \cdot \frac{3}{2} \frac{\cos \beta}{\beta^{3/2}} \left(\frac{\sin \beta}{\beta^{1/2}} - \frac{3}{2} \frac{\sin \beta}{\beta^{5/2}} \right) \right]$$

$$= \frac{2}{\pi} \left[\frac{9}{4} \frac{\cos^2 \beta}{\beta^3} + \left(\frac{\sin^2 \beta}{\beta} + \frac{9}{4} \frac{\sin^2 \beta}{\beta^5} - 3 \frac{\sin \beta}{\beta^{1/2}} \frac{\sin \beta}{\beta^{5/2}} \right) + 3 \frac{\cos \beta \sin \beta}{\beta^{3/2} \beta^{1/2}} - \frac{9}{2} \frac{\cos \beta \sin \beta}{\beta^{3/2} \beta^{5/2}} \right]$$

so

$$J'^2_{3/2}(\beta) = \frac{2}{\pi} \left[\frac{9}{4} \frac{\cos^2 \beta}{\beta^3} + \frac{\sin^2 \beta}{\beta} + \frac{9}{4} \frac{\sin^2 \beta}{\beta^5} - \frac{3 \sin^2 \beta}{\beta^3} + \frac{3 \cos \beta \sin \beta}{\beta^2} - \frac{9}{2} \frac{\cos \beta \sin \beta}{\beta^4} \right]$$

$$\text{so } \int_0^1 \left(\frac{\sin \beta x}{\beta x} - \cos \beta x \right)^2 dx = \frac{\beta \pi}{4} \left[\dots \right]$$

$$\int_0^1 \left(\frac{\sin \beta x}{\beta x} - \cos \beta x \right)^2 dx = \frac{1}{2} \left[\frac{9}{4} \frac{\cos^2 \beta}{\beta^2} + \frac{\sin^2 \beta}{\beta} + \frac{9}{4} \frac{\sin^2 \beta}{\beta^4} - \frac{3 \sin^2 \beta}{\beta^2} + \frac{3 \cos \beta \sin \beta}{\beta} - \frac{9}{2} \frac{\cos \beta \sin \beta}{\beta^3} \right]$$

the above is valid for β root of J_p . now I need to find how to replace β by 'a' \rightarrow

since 'a' is root of $\tan x = x$, then

$$\frac{\sin x}{\cos x} = x \quad \text{or} \quad \frac{\sin x}{x} = \cos x.$$

From $J_{3/2}(x) = \sqrt{\frac{2}{\pi x}} \left(\frac{\sin x}{x} - \cos x \right)$

replace x by $a \Rightarrow J_{3/2}(a) = \sqrt{\frac{2}{\pi a}} \left(\frac{\sin a}{a} - \cos a \right)$

$$= \sqrt{\frac{2}{\pi a}} (\cos a - \cos a)$$

$$= 0$$

good. This means 'a' is a zero of $J_{3/2}(x)$. hence

I am allowed now to use equation 19.10. so

replace β by 'a' in equation (1) will be valid

now \Rightarrow

$$\int_0^1 \left(\frac{\sin ax}{ax} - \cos ax \right)^2 dx = \frac{1}{2} \left[\frac{a}{4} \frac{\cos^2 a}{a^2} + \sin^2 a + \frac{a}{4} \frac{\sin^2 a}{a^4} - 3 \frac{\sin^2 a}{a^2} \right. \\ \left. + 3 \frac{\cos a \sin a}{a} - \frac{a}{2} \frac{\cos a \sin a}{a^3} \right]$$

now I can simplify RHS more using $\frac{\sin a}{\cos a} = a$ or $\boxed{\sin a = a \cos a}$

$$\text{so } I = \frac{a}{8} \frac{\cos^2 a}{a^2} + \frac{1}{2} a^2 \cos^2 a + \frac{a}{8} \frac{\cos^2 a a^2}{a^4} - \frac{3}{2} \frac{a^2 \cos^2 a}{a^2} + \frac{3 \cos a a \cos a}{2 a} \\ - \frac{a}{4} \frac{\cos a a \cos a}{a^3}$$

$$= \frac{a}{8} \frac{\cos^2 a}{a^2} + \frac{1}{2} a^2 \cos^2 a + \frac{a}{8} \frac{\cos^2 a}{a^2} - \frac{3}{2} \cos^2 a + \frac{3}{2} \cos^2 a - \frac{a}{4} \frac{\cos^2 a}{a^2}$$

$$= \cos^2 a \left[\frac{a}{8a^2} + \frac{a^2}{2} + \frac{a}{8a^2} - \frac{3}{2} + \frac{3}{2} - \frac{a}{4a^2} \right] = \cos^2 a \left[\frac{a}{8a^2} + \frac{a^2}{2} + \frac{a}{8a^2} - \frac{a}{4a^2} \right]$$

$$= \boxed{\frac{a^2}{2} \cos^2 a}$$

ch 12

19.3

Use 17.4 and 19.10 to write the orthogonality condition and the normalization integral for the spherical Bessel function $j_n(x)$.

from 19.10

$$\int_0^1 x J_p(ax) J_p(bx) dx = \begin{cases} 0 & a \neq b \\ \frac{1}{2} J_{p+1}^2(a) = \frac{1}{2} J_{p-1}^2(a) = \frac{1}{2} J_p'^2(a) & a=b \end{cases}$$

where a, b are roots of $J_p(x)$.

$$\text{from (17.4)} \quad j_n(x) = \sqrt{\frac{\pi}{2x}} \frac{J_{\frac{2n+1}{2}}(x)}{\frac{2n+1}{2}}$$

$$\text{so } J_{\frac{2n+1}{2}}(x) = j_n(x) \sqrt{\frac{2x}{\pi}}$$

$$\text{let } p = \frac{2n+1}{2} \Rightarrow \frac{2p-1}{2} = n$$

$$\text{so } J_p(x) = j_{\frac{2p-1}{2}}(x) \sqrt{\frac{2x}{\pi}} \Rightarrow \boxed{J_p(ax) = \frac{j_{\frac{2p-1}{2}}(ax) \sqrt{2ax}}{\sqrt{\pi}}}$$

so 19.10 becomes

$$\int_0^1 x j_{\frac{2p-1}{2}}(ax) j_{\frac{2p-1}{2}}(bx) \sqrt{\frac{2ax}{\pi}} \sqrt{\frac{2bx}{\pi}} dx = \begin{cases} 0 & \text{see below} \\ \end{cases}$$

$$\int_0^1 \sqrt{\frac{4abx^2}{\pi^2}} x j_{\frac{2p-1}{2}}(ax) j_{\frac{2p-1}{2}}(bx) dx = \begin{cases} 0 & \text{see later} \\ \end{cases}$$

$$\int_0^1 \frac{2x}{\pi} \sqrt{ab} x j_{\frac{2p-1}{2}}(ax) j_{\frac{2p-1}{2}}(bx) dx = \begin{cases} 0 & \text{see later} \\ \end{cases}$$

$$\frac{2}{\pi} \sqrt{ab} \int_0^1 x^2 j_{\frac{2p-1}{2}}(ax) j_{\frac{2p-1}{2}}(bx) dx = \begin{cases} 0 & a \neq b \\ \frac{1}{2} j_{\frac{2p-1}{2}}^2(a) = \frac{1}{2} j_{\frac{2p-1}{2}}^2(b) = \frac{1}{2} j_{\frac{2p-1}{2}}'^2(a) & a=b \end{cases}$$

QED

Ch 12
20.1 use table to evaluate the following limit

$$\lim_{x \rightarrow 0} \frac{J_4(x)}{J_2^2(x)}$$

this is for small x (since $x \rightarrow 0$) so use approximation for small x from table.

$$\text{for small } x \quad J_p(x) = \frac{1}{\Gamma(p+1)} \left(\frac{x}{2}\right)^p + O(x^{p+2})$$

hence above limit can be written as

$$\lim_{x \rightarrow 0} \frac{\frac{1}{\Gamma(4+1)} \left(\frac{x}{2}\right)^4 + O(x^{4+2})}{\left[\frac{1}{\Gamma(2+1)} \left(\frac{x}{2}\right)^2 + O(x^{2+2})\right]^2} = \frac{\lim_{x \rightarrow 0} \frac{1}{\Gamma(5)} \left(\frac{x}{2}\right)^4 + O(x^6)}{\left[\frac{1}{\Gamma(3)} \left(\frac{x}{2}\right)^2 + O(x^4)\right]^2}$$

$$= \lim_{x \rightarrow 0} \frac{\frac{1}{\Gamma(5)} \left(\frac{x}{2}\right)^4 + O(x^6)}{\frac{1}{\Gamma^2(3)} \left(\frac{x}{2}\right)^4 + O(x^4) + 2 \frac{1}{\Gamma(3)} \left(\frac{x}{2}\right)^2 O(x^4)}$$

now, for $x \rightarrow 0$, $\{O(x^4)\}^2$ is very small, since x^8 term. the same can be said as $O(x^6)$ and $O(x^4)$. These terms can be ignored in the limit.

$$\begin{aligned} \text{so } \lim_{x \rightarrow 0} &= \frac{\frac{1}{\Gamma(5)} \left(\frac{x}{2}\right)^4}{\frac{1}{\Gamma^2(3)} \left(\frac{x}{2}\right)^4} = \frac{\frac{1}{\Gamma(5)}}{\frac{1}{\Gamma^2(3)}} = \frac{\Gamma^2(3)}{\Gamma(5)} \\ &= \frac{(2!)^2}{(4!)} = \frac{2^2}{2 \times 3 \times 4} = \frac{1}{2 \times 3} = \boxed{\frac{1}{6}} \end{aligned}$$

Ch 12

21.13

Solve using Frobenius method. Show that conditions of Fuchs's theorem are satisfied.

$$x^2 y'' - x y' + y = 0$$

$$\rightarrow y = a_0 x^s + a_1 x^{s+1} + a_2 x^{s+2} + \dots + a_n x^{s+n} + \dots$$

$$y' = a_0 s x^{s-1} + a_1 (s+1) x^s + a_2 (s+2) x^{s+1} + \dots + a_n (s+n) x^{s+n-1}$$

$$\rightarrow x y' = a_0 s x^s + a_1 (s+1) x^{s+1} + a_2 (s+2) x^{s+2} + \dots + a_n (s+n) x^{s+n}$$

$$y'' = a_0 s(s-1) x^{s-2} + a_1 (s+1)s x^{s-1} + a_2 (s+2)(s+1) x^s + \dots$$

$$\rightarrow x^2 y'' = a_0 s(s-1) x^s + a_1 (s+1)s x^{s+1} + a_2 (s+2)(s+1) x^{s+2} + \dots$$

Set up table:

	x^s	x^{s+1}	x^{s+2}	x^{s+n}
y	a_0	a_1	a_2	a_n
$-x y'$	$-a_0 s$	$-a_1 (s+1)$	$-a_2 (s+2)$	$-a_n (s+n)$
$x^2 y''$	$a_0 s(s-1)$	$a_1 (s+1)s$	$a_2 (s+2)(s+1)$	$a_n (s+n)(s+n-1)$

First solve indicial equation.

from first column we get

$$a_0 - a_0 s + a_0 s(s-1) = 0$$

$$1 - s + s^2 - s = 0$$

for $a_0 \neq 0$ by hypothesis

$$\text{so } s^2 - 2s + 1 = 0 \Rightarrow s = \frac{-b \pm \sqrt{b^2 - 4ac}}{2a} = \frac{2 \pm \sqrt{4 - 4}}{2}$$

$$s = 1 \pm 0 = 1$$

observe one solution only since s has one value.

→

for $s=1$, Find recurrence formulas

$$a_n - a_n(s+n) + a_{n-1}(s+n-1) = 0$$

$$\text{i.e. } a_n - a_n(1+n) + a_{n-1}(1+n)(n) = 0$$

$$\text{so } a_n(1 - (1+n) + n + n^2) = 0$$

$$a_n(1 - 1 - n + n + n^2) = 0$$

$$a_n(n^2) = 0 \Rightarrow a_n = 0 \text{ for } n > 0.$$

so solution is only

$$y = a_0 x^1$$

$$\boxed{y_1 = a_0 x} \quad \text{this is the first solution.}$$

now need to show that conditions of Fuchs's are met.

$$\text{our equation are written as } y'' + f(x)y' + g(x)y = 0$$

$$\text{so } \left. \begin{array}{l} f(x) = -\frac{1}{x} \\ g(x) = \frac{1}{x^2} \end{array} \right\} \text{ for this problem. } y'' - \frac{1}{x}y' + \frac{1}{x^2}y = 0$$

$$\left. \begin{array}{l} xf(x) = -1 \\ x^2g(x) = 1 \end{array} \right\} \text{ these are expandable as power series}$$

$$\text{as } -1 = a_0 x^0, \quad a_0 = -1$$

$$\text{as } 1 = a_0 x^0, \quad a_0 = 1$$

here Fuchs's conditions are met. this means second

$$\text{solution } \boxed{y_2(x) = y_1(x) \ln(x) + \text{another Frobenius series}}$$

$$\text{so } \boxed{y_2(x) = a_0 x \ln(x) + \text{another Frobenius series}}$$

now I find the second solution \rightarrow

The second solution series can be found by

writing $y = a_0 x \ln(x) + \sum_{n=0}^{\infty} b_n x^{n+5}$ and sub
this into the DE given to solve for b_n terms. However, a
faster method is to use the substitution

$$y_2(x) = u(x) v(x)$$

where $u(x)$ is the first solution.

$$\text{so let } y_2(x) = \underbrace{a_0 x}_2 v(x) \text{ first solution.}$$

$$\text{from } x^2 y'' - x y' + y = 0 \quad \text{--- (1)}$$

$$y' = a_0 x v'(x) + a_0 v(x)$$

$$y'' = a_0 x v''(x) + v'(x) a_0 + a_0 v'(x)$$

so (1) becomes

$$x^2 [a_0 x v''(x) + v'(x) a_0 + a_0 v'(x)] - x [a_0 x v'(x) + a_0 v(x)] + a_0 x v(x) = 0$$

$$a_0 x^3 v'' + a_0 x^2 v' + a_0 x^2 v' - a_0 x^2 v' - a_0 x^2 v + a_0 x v = 0$$

$$a_0 x^3 v'' + a_0 x^2 v' = 0$$

$$x v'' + v' = 0$$

i.e. $x \frac{d^2 v(x)}{dx^2} + v'(x) = 0$. This is separable equation whose solution
as given in book page 529

$$v(x) = A + B \ln(x)$$

so second solution is $y_2 = u(x) v(x)$

$$y_2 = a_0 x [A + B \ln(x)] = \underbrace{A_1 x}_{y_1} + \underbrace{A_2 x \ln(x)}_{y_2}$$

$$\text{so general solution } y = y_1 + y_2 = \underbrace{a_0 x}_{y_1} + \underbrace{A_2 x \ln(x)}_{y_2}$$

$$= K_1 x + A_2 x \ln(x)$$

ch 12
21.15 solve $xy'' + xy' - 2y = 0$

3/5

let $y = a_0 x^s + a_1 x^{s+1} + a_2 x^{s+2} + \dots$

$$y' = a_0 s x^{s-1} + a_1 (s+1) x^s + a_2 (s+2) x^{s+1} + \dots$$

$$\rightarrow xy' = a_0 s x^s + a_1 (s+1) x^{s+1} + a_2 (s+2) x^{s+2} + \dots$$

$$y'' = a_0 s(s-1) x^{s-2} + a_1 (s+1)s x^{s-1} + a_2 (s+2)(s+1) x^s + \dots$$

$$\rightarrow xy'' = a_0 s(s-1) x^{s-1} + a_1 (s+1)s x^s + a_2 (s+2)(s+1) x^{s+1}$$

$$\rightarrow 2y = 2a_0 x^s + 2a_1 x^{s+1} + 2a_2 x^{s+2} + \dots$$

Set up Table

	x^{s-1}	x^s	x^{s+1}	x^{s+n}
xy''	$a_0 s(s-1)$	$a_1 (s+1)s$	$a_2 (s+2)(s+1)$	$a_{n+1} (s+n+1)(s+n)$
xy'	$a_0 s$	$a_1 (s+1)$		$a_n (s+n)$
$-2y$		$-2a_0$	$-2a_1$	$-2a_n$

so from first column, $a_0 s(s-1) = 0$

i.e. $s^2 - s = 0$ for $a_0 \neq 0$

$$\text{so } s = \frac{-b \pm \sqrt{b^2 - 4ac}}{2a} = \frac{1 \pm \sqrt{1-0}}{2} = \frac{1 \pm 1}{2}$$

$$= \frac{1+1}{2} \text{ or } 0 \quad \text{i.e. } \boxed{s=1 \text{ or } 0}$$

since the two values of s differ by an integer, then

the larger value of s gives the one solution.

so use $\boxed{s=1}$ \rightarrow

The recursive formula is

$$a_{n+1}(s+n+1)(s+n) + a_n(s+n) - 2a_n = 0$$

$$a_{n+1} = \frac{2a_n - a_n(s+n)}{(s+n+1)(s+n)} = \frac{a_n(2 - (s+n))}{(s+n+1)(s+n)}$$

but $s=1$. so

$$a_{n+1} = \frac{a_n(1-n)}{(2+n)(1+n)}$$

For $n=0$, $a_1 = \frac{a_0}{2}$

for $n=1$, $a_2 = \frac{a_1(0)}{3 \times 2} = 0$

for $n=2$, $a_3 = \frac{a_2(1-2)}{4 \times 3} = 0$ since $a_2=0$.

so all $a_n, n > 1$ are zero.

so first solution is

$$y_1 = a_0 x + \frac{a_0}{2} x^2$$

$$y_1 = a_0 \left(x + \frac{x^2}{2} \right)$$

now need to show that condition of Fuchs's are met

write DE as $y'' + f(x)y' + g(x)y = 0$

so $y'' + y' - \frac{2}{x}y = 0$.

i.e. $\begin{cases} f(x) = 1 \\ g(x) = -\frac{2}{x} \end{cases}$

i.e. $\underline{xf(x)}$ and $\underline{x^2g(x)}$

both are expandable in power series
this means second solution is

$$y_2(x) = y_1(x) \ln(x) + \text{another Frobenius Series}$$

now to find the second solution.

$$\text{let } y_2(x) = u(x) v(x)$$

$$\text{where } u(x) = y_1(x).$$

$$\text{so } y_2(x) = a_0 \left(x + \frac{x^2}{2}\right) v(x)$$

Why are you abandoning the form $y_2 = y_1 \cdot \ln x + \sum b_n x^n$?

sub into the DE \Rightarrow

$$x y_2''(x) + x y_2'(x) - 2 y_2(x) = 0$$

$$y_2'(x) = (a_0 + a_0 x) v(x) + a_0 \left(x + \frac{x^2}{2}\right) v'(x)$$

$$y_2''(x) = (a_0 + a_0 x) v' + v (a_0) + a_0 \left(x + \frac{x^2}{2}\right) v'' + v' (a_0 + a_0 x)$$

$$x y_2'(x) = (a_0 x + a_0 x^2) v + a_0 \left(x^2 + \frac{x^3}{2}\right) v'$$

$$x y_2''(x) = (a_0 x + a_0 x^2) v' + a_0 x v + a_0 \left(x^2 + \frac{x^3}{2}\right) v'' + v' (a_0 x + a_0 x^2)$$

DE is

$$a_0 \left(x^2 + \frac{x^3}{2}\right) v'' + 2(a_0 x + a_0 x^2) v' + a_0 x v + a_0 \left(x^2 + \frac{x^3}{2}\right) v' + (a_0 x + a_0 x^2) v - 2 a_0 \left(x + \frac{x^2}{2}\right) v = 0$$

$$v'' \left(a_0 x^2 + a_0 \frac{x^3}{2}\right) + v' \left(2 a_0 x + 2 a_0 x^2 + a_0 x^2 + \frac{a_0 x^3}{2}\right) + v \left(a_0 x + a_0 x + a_0 x^2 - 2 a_0 x - a_0 x^2\right) = 0$$

$$v'' \left(a_0 x^2 + a_0 \frac{x^3}{2}\right) + v' \left(2 a_0 x + 3 a_0 x^2 + \frac{1}{2} a_0 x^3\right) + v(0) = 0$$

$$v'' \left(a_0 x + a_0 \frac{x^2}{2}\right) + v' \left(2 a_0 + 3 a_0 x + \frac{1}{2} a_0 x^2\right) = 0$$

$$\text{or } v'' \left(x + \frac{x^2}{2}\right) + v' \left(2 + 3x + \frac{1}{2} x^2\right) = 0 \quad \text{since } a_0 \neq 0.$$

Solve for $v(x)$

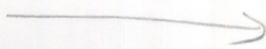

$$v'' + v' \left(\frac{2+3x+\frac{1}{2}x^2}{x+\frac{x^2}{2}} \right) = 0$$

$$v'' = -v' \left(\frac{2+3x+\frac{1}{2}x^2}{x+\frac{x^2}{2}} \right) = -v' \left(\frac{4+6x+x^2}{2x+x^2} \right)$$

$$\text{ie } \frac{d^2v}{dx^2} = - \left(\frac{4+6x+x^2}{2x+x^2} \right) \frac{dv}{dx}$$

$$\text{let } \frac{dv}{dx} = Y(x)$$

$$\text{so } \frac{dY}{dx} = - \left(\frac{4+6x+x^2}{2x+x^2} \right) Y$$

$$\text{so } \frac{dY}{Y} = - \left(\frac{4+6x+x^2}{2x+x^2} \right) dx$$

$$\text{so } \ln Y = - \int \frac{4+6x+x^2}{2x+x^2} dx = - \int \frac{4+6x+x^2}{x(x+2)} dx$$

do Partial Fraction

$$\frac{A}{x} + \frac{Bx+C}{x+2} = \frac{A(x+2) + Bx^2+Cx}{x(x+2)} = \frac{4+6x+x^2}{x(x+2)}$$

$$Ax + 2A + Bx^2 + Cx = 4 + 6x + x^2$$

$$\text{so } A+C=6$$

$$2A = 4$$

$$B = 1$$

$$\left. \begin{array}{l} \text{so } A+C=6 \\ 2A=4 \\ B=1 \end{array} \right\} A=2 \Rightarrow C=6-A=4$$

$$\text{so } - \int \left(\frac{2}{x} + \frac{x+4}{x+2} \right) dx = \ln Y$$

integrating constant.

$$A \ln Y = - \left[2 \ln(x) + x + 2 \ln(x+2) \right]$$

$$\text{so } Y = B \exp \left(2 \ln(x) + x + 2 \ln(x+2) \right)$$

$$\text{ie } \frac{dv}{dx} = B \exp \left(2 \ln(x) + x + 2 \ln(x+2) \right) \rightarrow$$

$$\text{so } v = B \int \exp(2 \ln(x) + x + 2 \ln(x+2)) dx$$

$$v(x) = B \int e^x e^{(2 \ln(x))} e^x e^{2 \ln(x+2)} dx$$

$$= B \int e^x (e^{\ln x})^2 (e^{\ln(x+2)})^2 dx$$

$$= B \int e^x x^2 (x+2)^2 dx$$

$$= B \int e^x x^2 (x^2 + 4x + 4) dx$$

$$= B \int e^x (x^4 + 4x^3 + 4x^2) dx$$

$$= B \left[\int x^4 e^x + 4 \int e^x x^3 + 4 \int e^x x^2 \right]$$

$$v(x) = B e^x (8 - 8x + 4x^2 + x^4) + C \quad \begin{array}{l} \text{integration} \\ \text{constant} \end{array}$$

so second solution is

$$y_2 = u(x) v(x)$$

$$y_2 = a_0 \left(x + \frac{x^2}{2}\right) \left(B e^x (8 - 8x + 4x^2 + x^4) + C \right)$$

so general solution is

$$y = y_1(x) \ln(x) + y_2(x)$$

$$= a_0 \left(x + \frac{x^2}{2}\right) \ln(x) + a_0 \left(x + \frac{x^2}{2}\right) \left(B e^x (8 - 8x + 4x^2 + x^4) + C \right)$$

$$y = K_1 \left(x + \frac{x^2}{2}\right) \ln(x) + K_2 \left(x + \frac{x^2}{2}\right) e^x (8 - 8x + 4x^2 + x^4)$$

K_1, K_2 arbitrary constants.

ch 12
 21.18 solve $x^2 y'' - 3xy' + 4y = 0$, $u = x^2$

here first solution is given.

so first look at Fuchs's Conditions.

$$y'' - \frac{3}{x} y' + \frac{4}{x^2} y = 0.$$

$$\left. \begin{aligned} f(x) &= -\frac{3}{x} \Rightarrow x f(x) = -3 \\ g(x) &= \frac{4}{x^2} \Rightarrow x^2 g(x) = 4 \end{aligned} \right\} \begin{array}{l} \text{regular or has nonessential} \\ \text{singularity at origin.} \end{array}$$

let $y_2 = u(x) v(x) = x^2 v(x)$

$$\text{so } y_2' = x^2 v' + 2xv$$

$$y_2'' = x^2 v'' + 2xv' + 2xv' + 2v$$

$$x^2 y_2'' = x^4 v'' + 4x^3 v' + 2x^2 v$$

$$-3xy_2' = -3x^3 v' - 6x^2 v$$

so DE becomes

$$(x^4 v'' + 4x^3 v' + 2x^2 v) - 3x^3 v' - 6x^2 v + 4x^2 v = 0$$

$$v''(x^4) + v'(4x^3 - 3x^3) + v(2x^2 - 6x^2 + 4x^2) = 0$$

$$\boxed{x^4 v'' + x^3 v' = 0}$$

$$v'' = -\frac{x^3}{x^4} v'$$

$$v'' = -\frac{1}{x} v'$$

$$\frac{dv}{dx^2} = -\frac{1}{x} \frac{dv}{dx}$$

let $\frac{dv}{dx} = Y(x)$

$$\frac{dY}{dx} = -\frac{1}{x} Y \Rightarrow \frac{dY}{Y} = -\frac{1}{x} dx \rightarrow$$

$$\ln Y(x) = -\ln(x) + C$$

$$\text{so } e^{-\ln(x)+C} = Y(x).$$

$$\text{i.e. } \frac{dv}{dx} = A e^{-\ln(x)} = A \frac{1}{x}$$

$$\text{so } dv = A \frac{dx}{x}$$

$$\text{so } \boxed{v(x) = A \ln(x) + B}$$

$$\text{So second solution } y_2 = x^2 v(x)$$

$$y_2 = x^2 (A \ln(x) + B)$$

So general solution

$$y = y_1 + y_2$$

$$= x^2 + x^2 (A \ln(x) + B)$$

$$= x^2 + A x^2 \ln(x) + B x^2$$

$$\boxed{y(x) = C x^2 + A x^2 \ln(x)}$$

4.7 HW 7

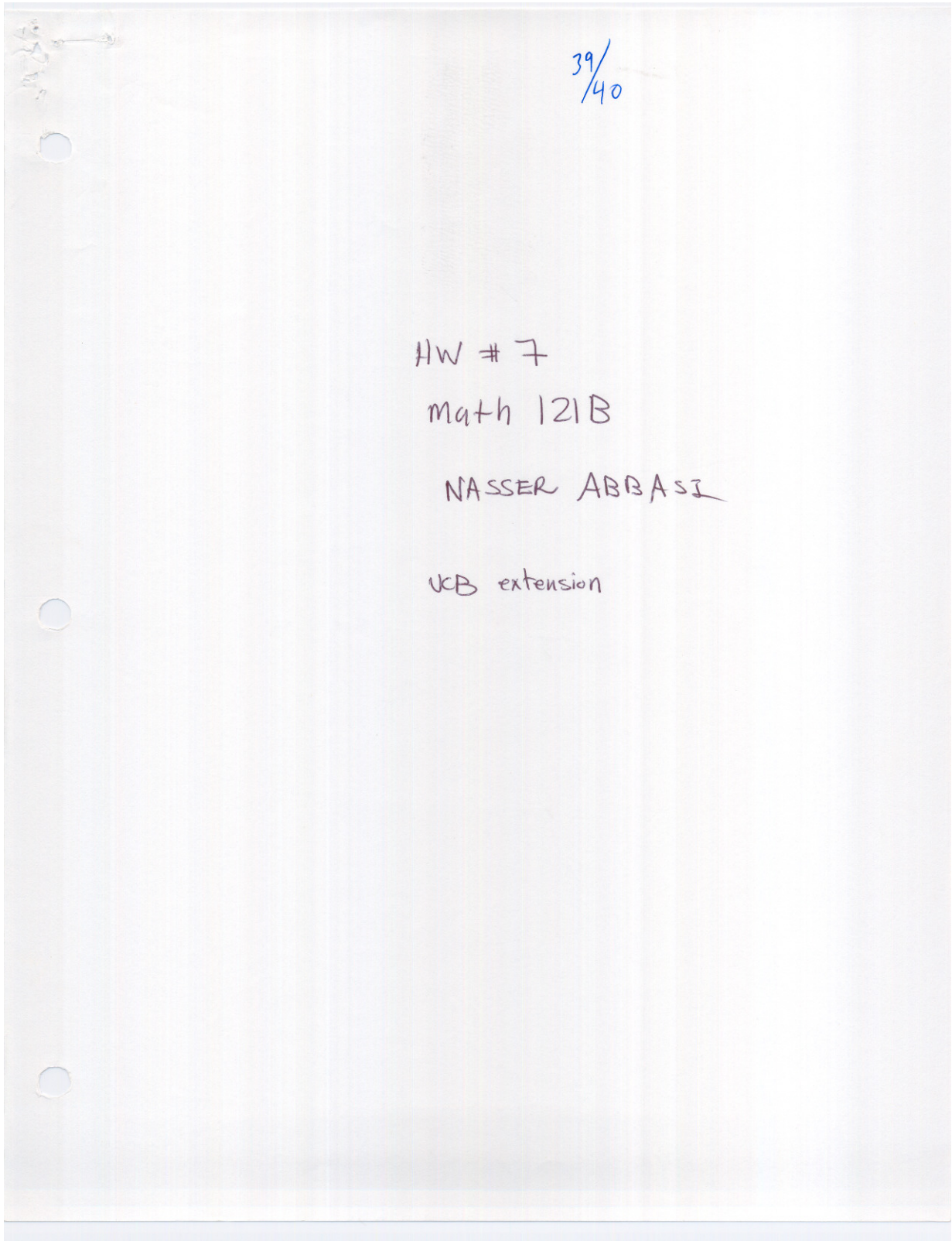

ch 12

22.1

verify equations (22.2) (22.3) (22.4) and (22.8)

$$22.2 \quad (D-x)(D+x)y = \left(\frac{d}{dx} - x\right)(y' + xy) = y'' - x^2y + y \quad \text{--- (a)}$$

$$\text{and } (D+x)(D-x)y = y'' - x^2y - y. \quad \text{--- (b)}$$

note $D = \frac{d}{dx}$

$$\text{eq a is } \left(\frac{d}{dx} - x\right)\left(\frac{d}{dx} + x\right)y$$

$$= \left(\frac{d}{dx} - x\right)\left(\frac{dy}{dx} + xy\right)$$

$$= \frac{d}{dx}\left(\frac{dy}{dx}\right) + \frac{d}{dx}(xy) - x\frac{dy}{dx} - x^2y$$

$$= \frac{d^2y}{dx^2} + \left(x\frac{dy}{dx} + y\frac{dx}{dx}\right) - x\frac{dy}{dx} - x^2y$$

$$= y'' + \underline{xy'} + y - \underline{xy'} - x^2y$$

$$= y'' + y - x^2y \quad \text{verified ok.}$$

for b

$$\left(\frac{d}{dx} + x\right)\left(\frac{d}{dx} - x\right)y =$$

$$= \left(\frac{d}{dx} + x\right)\left(\frac{d}{dx}y - xy\right)$$

$$= \frac{d}{dx}\left(\frac{dy}{dx}\right) - \frac{d}{dx}(xy) + x\frac{dy}{dx} - x^2y$$

$$= \frac{d^2y}{dx^2} - \left(x\frac{dy}{dx} + y\frac{dx}{dx}\right) + x\frac{dy}{dx} - x^2y$$

$$= y'' - xy' - y + xy' - x^2y$$

$$= y'' - y - x^2y \quad \text{verified ok.}$$

for 22.3 \longrightarrow

(22.3) need to verify $(D-x)(D+x)y_n = -2ny_n$.

since $(D-x)(D+x)y = y'' - x^2y + y$ from 22.2

then $(D-x)(D+x)y_n = y_n'' - x^2y_n + y_n$

but $y_n'' - x^2y_n = -(2n+1)y_n$ from 22.1

so $(D-x)(D+x)y_n = -(2n+1)y_n + y_n$

so $(D-x)(D+x)y_n = -2ny_n - y_n + y_n = \boxed{-2ny_n}$

to verify (22.4)

$(D+x)(D-x)y_n = -2(n+1)y_n$.

since $(D+x)(D-x)y = y'' - x^2y - y$ from 22.2

Then $(D+x)(D-x)y_n = y_n'' - x^2y_n - y_n$

so $(D+x)(D-x)y_n = -(2n+1)y_n - y_n$

$= -2ny_n - y_n - y_n$

$= -2ny_n - 2y_n = \boxed{-2(n+1)y_n}$

to verify 22.8

$y_{m-1} = (D+x)y_m$

from (22.4) $(D+x)(D-x)y_n = -2(n+1)y_n$

from (22.5) $(D+x)(D-x)[(D+x)y_m] = -2(m)[(D+x)y_m]$

if $y_n = (D+x)y_m$ and $(n+1) = m$, then equations are identical. then $n = m-1$ from.

so $\boxed{y_{m-1} = (D+x)y_m}$ by replacing n by $m-1$ in this.

Ch 12

22.4 using 22.12 find Hermite poly given in 22.13, then use 22.17b to find $H_3(x)$ and $H_4(x)$.

$$22.12 \text{ is } H_n(x) = (-1)^n e^{x^2} \frac{d^n}{dx^n} e^{-x^2}$$

$$22.17b \text{ is } H_{n+1}(x) = 2x H_n(x) - 2n H_{n-1}(x)$$

$$22.13 \text{ is } H_0(x) = 1$$

$$H_1(x) = 2x$$

$$H_2(x) = 4x^2 - 2$$

from 22.12, let $n=0$

$$\begin{aligned} H_0(x) &= (-1)^0 e^{x^2} \frac{d^0}{dx^0} e^{-x^2} \\ &= 1 e^{x^2} (e^{-x^2}) = \boxed{1} \end{aligned}$$

let $n=1$

$$\begin{aligned} H_1(x) &= (-1)^1 e^{x^2} \frac{d^1}{dx^1} e^{-x^2} \\ &= (-1) e^{x^2} (-2x e^{-x^2}) \\ &= -e^{x^2} (-2x e^{-x^2}) \\ &= \boxed{2x} \quad \checkmark \end{aligned}$$

let $n=2$

$$\begin{aligned} H_2(x) &= (-1)^2 e^{x^2} \frac{d^2}{dx^2} (e^{-x^2}) \\ &= 1 e^{x^2} \frac{d}{dx} (-2x e^{-x^2}) \\ &= e^{x^2} (-2x(-2x e^{-x^2}) + e^{-x^2}(-2)) \\ &= e^{x^2} (4x^2 e^{-x^2} - 2e^{-x^2}) \\ &= \boxed{4x^2 - 2} \quad \checkmark \end{aligned}$$

now use 22.17b to find H_3 and $H_4 \rightarrow$

$$\text{from 22.17b } H_{n+1}(x) = 2xH_n - 2nH_{n-1}$$

$$\text{let } n=2$$

$$\begin{aligned} \text{so } H_3 &= 2xH_2 - 2(2)H_1 \quad \checkmark \\ &= 2x(4x^2-2) - 4(2x) \\ &= 8x^3 - 4x - 8x \\ &= \boxed{8x^3 - 12x} \end{aligned}$$

$$\text{let } n=3$$

$$\begin{aligned} H_4 &= 2xH_3 - 2(3)H_2 \\ &= 2x(8x^3-12x) - 6(4x^2-2) \\ &= 16x^4 - 24x^2 - 24x^2 + 12 \\ H_4 &= \boxed{16x^4 - 48x^2 + 12} \quad \checkmark \end{aligned}$$

ch 12

22.5

Solve Hermite DE

$$y'' - 2xy' + 2py = 0$$

by power series.

$$\text{let } y = a_0 + a_1x + a_2x^2 + a_3x^3 + a_4x^4 + \dots$$

$$y' = a_1 + 2a_2x + 3a_3x^2 + 4a_4x^3 + \dots$$

$$\rightarrow -2xy' = -2xa_1 - (2 \cdot 2)a_2x^2 - (2 \cdot 3)a_3x^3 - (2 \cdot 4)a_4x^4 - \dots$$

$$\rightarrow y'' = 2a_2 + (2 \cdot 3)a_3x + (3 \cdot 4)a_4x^2 + \dots$$

$$\rightarrow 2py = 2pa_0 + 2pa_1x + 2pa_2x^2 + \dots$$

Set up Table

	x^0	x^1	x^2	x^n
y''	$2a_2$	$6a_3$	$12a_4$	$(n+1)(n+2)a_{n+2}$
$-2xy'$	$-2a_1$	$-2a_1$	$-4a_2$	$-2(n)a_n$
$2py$	$2pa_0$	$2pa_1$	$2pa_2$	$2pa_n$

from first column, $2pa_0 + 2a_2 = 0$

$$\text{so } a_2 = \frac{-2pa_0}{2} = \boxed{-pa_0}$$

recursive equation

$$a_{n+2}(n+1)(n+2) - a_n 2n + a_n 2p = 0$$

$$a_{n+2} = \frac{-a_n(2n-2p)}{(n+1)(n+2)}$$

→

$$n=1 \quad a_{\frac{1+2}{3}} = -a_1 \frac{(2 \cdot 1 - 2P)}{(1+1)(1+2)}$$

$$n=2 \quad a_{\frac{2+2}{4}} = -a_2 \frac{(2 \cdot 2 - 2P)}{(2+1)(2+2)} = +Pa_0 \frac{(2 \cdot 2 - 2P)}{(2+1)(2+2)}$$

$$\begin{aligned} n=3 \quad a_{\frac{3+2}{5}} &= -a_3 \frac{(2 \cdot 3 - 2P)}{(3+1)(3+2)} = - \left(-a_1 \frac{(2 \cdot 1 - 2P)}{(1+1)(1+2)} \right) \frac{2 \cdot 3 - 2P}{(3+1)(3+2)} \\ &= a_1 \frac{(2 \cdot 1 - 2P)(2 \cdot 3 - 2P)}{(1+1)(1+2)(1+3)(3+2)} \end{aligned}$$

$$\begin{aligned} n=4 \quad a_{\frac{4+2}{6}} &= -a_4 \frac{(2 \cdot 4 - 2P)}{(4+1)(4+2)} = - \left[Pa_0 \frac{(2 \cdot 2 - 2P)}{(2+1)(2+2)} \right] \frac{(2 \cdot 4 - 2P)}{(4+1)(4+2)} \\ &= -Pa_0 \frac{(2 \cdot 2 - 2P)(2 \cdot 4 - 2P)}{(2+1)(2+2)(4+1)(4+2)} \end{aligned}$$

$$\text{So } y = a_0 + a_1 x + (-Pa_0)x^2 + \left(-a_1 \frac{(2 \cdot 1 - 2P)}{(1+1)(1+2)} \right) x^3 + \dots$$

$$\begin{aligned} y &= a_0 \left(1 - Px^2 + P \frac{(2 \cdot 2 - 2P)}{(2+1)(2+2)} x^4 - P \frac{(2 \cdot 2 - 2P)(2 \cdot 4 - 2P)}{(2+1)(2+2)(4+1)(4+2)} x^6 + \dots \right) \\ &+ a_1 \left(x - \frac{2 \cdot 1 - 2P}{2 \cdot 3} x^3 + \frac{(2 \cdot 1 - 2P)(2 \cdot 3 - 2P)}{2 \cdot 3 \cdot 4 \cdot 5} x^5 - \dots \right) \end{aligned}$$

$$\begin{aligned} y &= a_0 \left(1 - Px^2 + P \frac{(2 \cdot 2 - 2P)}{3 \cdot 4} x^4 - P \frac{(2 \cdot 2 - 2P)(2 \cdot 4 - 2P)}{3 \cdot 4 \cdot 5 \cdot 6} x^6 + \dots \right) \\ &+ a_1 \left(x - \frac{(2 \cdot 1 - 2P)}{2 \cdot 3} x^3 + \frac{(2 \cdot 1 - 2P)(2 \cdot 3 - 2P)}{2 \cdot 3 \cdot 4 \cdot 5} x^5 - \dots \right) \end{aligned}$$

To make denominator a factorial, multiply by $\frac{z}{2}$ the a_0 series:

$$y = a_0 \left(\frac{z}{2} - \frac{2P}{2}x^2 + \frac{z(z-2P)}{4!}x^4 - \frac{z(z-2P)(z(2-P)(2(4-P)-2P)}{6!}x^6 + \dots \right) \\ + a_1 \left(x - \frac{z(z-2P)}{3!}x^3 - \frac{z(z-2P)(z(3-P)(2(3-P)-2P)}{5!}x^5 - \dots \right)$$

So The general term for a_0 series is :

$$(a_0) \frac{z^{2n} P \left((z-2P)(4-P)(6-P) \dots ((2n-2)-P) \right)}{2n!} x^{2n}$$

one of these is zero for even P

when I have extracted 'z' from each product to get the z^{2n} part. for example, the above for x^6 is $x^{2 \times 3}$, i.e. $n=3$ is $\frac{z^6 P (z-2P)(4-P)}{6!} x^6$ etc...

so we see clearly now that if P is ^{positive} even, then the series terminates. For example, if $P=N$, then the $(N-P)$ term will cause the term to be zero, and each term after that to be zero as well..

for the a_1 series, general term is :

$$(a_1) \frac{z^{2n} \left((1-P)(3-P)(5-P)(7-P) \dots (2n+1-P) \right)}{(2n+1)!} x^{2n+1}$$

one of these will be zero for odd P

here we see if P is odd, then one of the terms in the product $(1-P)(3-P) \dots (2n+1-P)$ will be zero. and so the whole term is zero. and series terminates.

so, since P can be either odd or even, then solution will only contain the a_0 or a_1 series.

to find H_0, H_1 and H_2 .

the polynomials are

$$y = a_0 \left(1 - Px^2 + \frac{2(4-2P)P}{24} x^4 - \dots \right) + a_1 \left(x - \frac{(2-2P)}{6} x^3 + \dots \right)$$

$$y = a_0 \left(1 - Px^2 + \frac{1}{12} (4P - 2P^2) x^4 - \dots \right) + a_1 \left(x - \frac{(1-P)}{3} x^3 + \dots \right) \\ = a_0 \left(1 - Px^2 \right) + \frac{1}{8} (2P - P^2) x^4 - \dots + a_1 \left(x - \frac{(1-P)}{3} x^3 + \dots \right)$$

so now look for polynomials with highest order term as

$$(2x)^0, (2x)^1, (2x)^2$$

$$\begin{array}{ccc} \downarrow & \downarrow & \downarrow \\ a_0 \cdot 1 & a_1 x & a_0 (-Px^2) + a_0 x \\ \downarrow & \downarrow & \downarrow \\ a_0 & a_1 x & -Pa_0 x^2 + a_0 x \\ (H_0) & (H_1) & (H_2) \end{array}$$

let $a_0 = 1$
we get
 $H_0 = 1$

let $a_1 = 2$
we get
 $H_1 = 2x$

let $a_0 = 2, P = 2$
we get
 $4x^2 - 2$

Ch 12

22.7

Prove that the functions $H_n(x)$ are orthogonal on $(-\infty, \infty)$ w.r.t. weight function e^{-x^2} .

Hermite DE is $y'' - 2xy' + 2ny = 0$ — (1)

to show they are orthogonal, need to show that

$$\int_{-\infty}^{\infty} e^{-x^2} H_n H_m dx = 0 \quad n \neq m.$$

where H_n is solution to $y'' - 2xy' + 2ny = 0$

and H_m is solution to $y'' - 2xy' + 2my = 0$

using hint, I write (1) as

$$e^{x^2} \frac{d}{dx} (e^{-x^2} y') + 2ny = 0$$

since H_n is solution to \curvearrowright , then can write

and $e^{x^2} \frac{d}{dx} (e^{-x^2} H_n') + 2n H_n = 0$
 $e^{x^2} \frac{d}{dx} (e^{-x^2} H_m') + 2m H_m = 0$

multiply first equation by H_m , second by H_n and subtract from each others \Rightarrow

$$H_m e^{x^2} \frac{d}{dx} (e^{-x^2} H_n') + 2n H_n H_m - H_n e^{x^2} \frac{d}{dx} (e^{-x^2} H_m') - 2m H_m H_n = 0$$

divide by $e^{x^2} \Rightarrow$

$$H_m \frac{d}{dx} (e^{-x^2} H'_n) + (2n-2m) H_n H_m e^{-x^2} - H_n \frac{d}{dx} (e^{-x^2} H'_m) = 0$$

$$\text{or } H_m \frac{d}{dx} (e^{-x^2} H'_n) - H_n \frac{d}{dx} (e^{-x^2} H'_m) + 2(n-m) H_n H_m e^{-x^2} = 0$$

integrate $\int_{-\infty}^{\infty} \Rightarrow$

$$\int_{-\infty}^{\infty} H_m \frac{d}{dx} (e^{-x^2} H'_n) dx - \int_{-\infty}^{\infty} H_n \frac{d}{dx} (e^{-x^2} H'_m) dx + 2(n-m) \int_{-\infty}^{\infty} H_n H_m e^{-x^2} dx = 0 \quad (3) \quad \text{equation (A)}$$

now need to show that $\int_{-\infty}^{\infty} H_m \frac{d}{dx} (e^{-x^2} H'_n) dx$ and $\int_{-\infty}^{\infty} H_n \frac{d}{dx} (e^{-x^2} H'_m) dx$ integrals are zero to be able to prove the orthogonality. look at first integral: (1)

$$\begin{aligned} \int_{-\infty}^{\infty} H_m \frac{d}{dx} (e^{-x^2} H'_n) dx &= \int_{-\infty}^{\infty} H_m (e^{-x^2} H''_n - H'_n 2x e^{-x^2}) dx \\ &= \int_{-\infty}^{\infty} H_m e^{-x^2} H''_n - 2x H_m H'_n e^{-x^2} dx = \int_{-\infty}^{\infty} e^{-x^2} (H_m H''_n - 2x H_m H'_n) dx \end{aligned}$$

look at second integral: (2)

$$\begin{aligned} \int_{-\infty}^{\infty} H_n \frac{d}{dx} (e^{-x^2} H'_m) dx &= \int_{-\infty}^{\infty} H_n (e^{-x^2} H''_m - 2x e^{-x^2} H'_m) dx \\ &= \int_{-\infty}^{\infty} e^{-x^2} (H_n H''_m - 2x H_n H'_m) dx \end{aligned}$$

so (1) - (2) since

$$\int_{-\infty}^{\infty} e^{-x^2} (H_m H''_n - 2x H_m H'_n - H_n H''_m + 2x H_n H'_m) dx$$

$$\int_{-\infty}^{\infty} e^{-x^2} (H_m H''_n - H_n H''_m + 2x (H_n H'_m - H_m H'_n)) dx \quad (*)$$

\rightarrow

$$\begin{aligned} \frac{d}{dx} H_m(e^{-x^2} H'_n) &= H_m(-2xe^{-x^2} H'_n + e^{-x^2} H''_n) + H'_m(e^{-x^2} H'_n) \\ &= e^{-x^2} (-2x H_m H'_n + \underline{H_m H''_n} + H'_m H'_n) \quad \text{--- (1)} \end{aligned}$$

$$\begin{aligned} \frac{d}{dx} H_n(e^{-x^2} H'_m) &= H_n(-2xe^{-x^2} H'_m + e^{-x^2} H''_m) + (e^{-x^2} H'_m) H'_n \\ &= e^{-x^2} (-2x H_n H'_m + \underline{H_n H''_m} + H'_m H'_n) \quad \text{--- (2)} \end{aligned}$$

(1) - (2) since

$$\begin{aligned} &e^{-x^2} (-2x H_m H'_n + \underline{H_m H''_n} + H'_m H'_n + 2x H_n H'_m - \underline{H_n H''_m} - H'_m H'_n) \\ &e^{-x^2} (H_m H''_n - H_n H''_m + 2x(H_n H'_m - H_m H'_n)) \quad \text{--- (3)} \end{aligned}$$

looking at (3) and at integral (*) in last page

This shows I can write integral (*) as

$$\int_{-\infty}^{\infty} \left[\frac{d}{dx} H_m(e^{-x^2} H'_n) - \frac{d}{dx} H_n(e^{-x^2} H'_m) \right] dx \quad \checkmark$$

$$\int_{-\infty}^{\infty} \frac{d}{dx} (H_m(e^{-x^2} H'_n) - H_n(e^{-x^2} H'_m)) dx$$

using Fundamental theory of Calculus

$$\int \frac{d}{dx} g(x) dx = g(x), \text{ then value of}$$

above integral is

$$\left[H_m(e^{-x^2} H'_n) - H_n(e^{-x^2} H'_m) \right]_{-\infty}^{\infty} \rightarrow$$

$$= \left[e^{-x^2} (H_m H'_n - H_n H'_m) \right]_{-\infty}^{\infty}$$

since x^2 is always positive, the e^{-x^2} at ∞ is zero and e^{-x^2} at $-\infty$ is zero also.

So for the integral we set $[0-0] = 0$. ✓

hence, looking 2 pages ago at equation labeled (A)

it shows that

$$\boxed{2(n-m) \int_{-\infty}^{\infty} H_n H_m e^{-x^2} dx = 0} \quad \text{is what left,}$$

since the other 2 integrals are zero as shown above.

so this means that if $n \neq m$, ✓ then

$$\int_{-\infty}^{\infty} H_n H_m e^{-x^2} dx = 0$$

but this is the definition of orthogonal functions w.r.t. weight e^{-x^2} . so H_n, H_m are orthogonal w.r.t. e^{-x^2} .

Q.E.D

ch 12

22.8

in the generating function 22.16, expand the exponential in power series and collect powers of h to obtain the first few Hermite polynomials. Verify

$$\frac{\partial^2 \phi}{\partial x^2} - 2x \frac{\partial \phi}{\partial x} + 2h \frac{\partial \phi}{\partial h} = 0.$$

Substitute the series in 22.16 into this identity to prove that $H_n(x)$ in 22.16 satisfy 22.14.

Solution

eg 22.16 (generating function for Hermite poly) is

$$\phi(x, h) = e^{2xh - h^2} = \sum_{n=0}^{\infty} H_n(x) \frac{h^n}{n!}.$$

expand exp function in power series around 0. we set

$$e^z = 1 + z + \frac{z^2}{2!} + \frac{z^3}{3!} + \dots$$

$$\text{so } e^{2xh - h^2} = 1 + (2xh - h^2) + \frac{(2xh - h^2)^2}{2} + \frac{(2xh - h^2)^3}{3!} + \dots$$

$$= 1 + (2xh - h^2) + \frac{(4x^2h^2 + h^4 - 4xh^3)}{2} + \frac{(2xh - h^2)(4x^2h^2 + h^4 - 4xh^3)}{6} + \dots$$

$$= 1 + (2xh - h^2) + \frac{4x^2h^2}{2} + \frac{h^4}{2} - \frac{4xh^3}{2} + \frac{8x^3h^3}{3!} + \frac{2xh^5}{3!} - \frac{8x^2h^4}{3!} - \frac{4x^2h^4}{3!} - \frac{h^6}{3!} + \frac{4xh^5}{3!} + \dots$$

$$= h^0(1) + h^1(2x) + h^2(-1 + 2x^2) + h^3(-2x + \frac{4}{3}x^3) + \dots$$

\rightarrow

so from 22.16 we get

$$\begin{aligned}
 h^0(1) + h'(2x) + h^2(-1+2x^2) + h^3(-2x + \frac{4}{3}x^3) + \dots \\
 = H_0(x) h^0 + H_1(x) h^1 + H_2(x) \frac{h^2}{2} + H_3(x) \frac{h^3}{3!} + \dots
 \end{aligned}$$

equating coefficients of h , we set

$$H_0(x) = 1$$

$$H_1(x) = 2x$$

$$\frac{H_2(x)}{2} = (-1 + 2x^2)$$

$$\frac{H_3(x)}{3!} = -2x + \frac{4}{3}x^3$$

so

$$\begin{aligned}
 H_0 &= 1 \\
 H_1 &= 2x \\
 H_2 &= -2 + 4x^2 \\
 H_3 &= -12x + 8x^3
 \end{aligned}$$

now verify identity $\frac{\partial^2 \phi}{\partial x^2} - 2x \frac{\partial \phi}{\partial x} + 2h \frac{\partial \phi}{\partial h} = 0$.

using expansion we got (using first 3 terms of expansion only)

$$\phi(x, h) = 1 + 2xh + (-1+2x^2)h^2 - (-2x + \frac{4}{3}x^3)h^3 + \dots$$

find $\frac{\partial \phi}{\partial x}$, $\frac{\partial^2 \phi}{\partial x^2}$, $\frac{\partial \phi}{\partial h}$, and substitute to see if identity valid \rightarrow

$$\frac{\partial \phi}{\partial x} = 2h + 4xh^2 - 2h^3$$

$$\frac{\partial^2 \phi}{\partial x^2} = 4h^2 - 6xh^2$$

$$\frac{\partial \phi}{\partial h} = 1 + 2x - 2h + 4x^2h - 3h^2 + 2x^3$$

$$\text{so } \frac{\partial^2 \phi}{\partial x^2} - 2x \frac{\partial \phi}{\partial x} + 2h \frac{\partial \phi}{\partial h} =$$

$$= (4h^2 - 6xh^2) - 2x(2h + 4xh^2) + 2h(1 + 2x - 2h + 4x^2h - 3h^2 + 2x^3)$$

$$= 4h^2 - 6xh^2 - 4xh - 8x^2h^2 + 2h + 4xh - 4h^2 + 8x^2h^2 + 2x^3h - 6x^3h^2 + 4x^3h^2$$

$$= \boxed{0}$$

hence Hermite polynomials generated by generating function satisfy Hermite DE 22.14 $y'' - 2xy' + 2ny = 0$

now to verify that highest term in $H_n(x)$ is $(2x)^n$.

looking at

$$H_0 = 1 \quad \rightarrow \quad n=0, \text{ highest term } (2x)^0 = 1 \quad \text{OK.}$$

$$H_1 = 2x \quad \rightarrow \quad n=1, (2x)^1 = 2x \quad \text{OK}$$

$$H_2 = -2 + 4x^2 \quad \rightarrow \quad n=2, (2x)^2 = 4x^2 \quad \text{OK}$$

$$H_3 = -12x + 8x^3 \quad \rightarrow \quad n=3, (2x)^3 = 8x^3 \quad \text{OK.}$$

all verified.

Ch 12
22.12

4/5

using Leibniz rule (section 3) carry out the differentiation in 22.18 to obtain 22.19

$$22.18: L_n(x) = \frac{1}{n!} e^x \frac{d^n}{dx^n} (x^n e^{-x})$$

$$22.19: L_n(x) = 1 - nx + \frac{n(n-1)}{2!} \frac{x^2}{2!} - \frac{n(n-1)(n-2)}{3!} \frac{x^3}{3!} + \dots + \frac{(-1)^n x^n}{n!}$$

$$= \sum_{m=0}^n (-1)^m \binom{n}{m} \frac{x^m}{m!} \quad \text{Laguerre polynomials.}$$

Leibniz rule is used to differentiate a product

$$\frac{d^n}{dx^n} (uv) = u v^{(n)} + n u^{(1)} v^{(n-1)} + \frac{n(n-1)}{2!} u^{(2)} v^{(n-2)} + \dots$$

where $v^{(n)}$ means $\frac{d^n}{dx^n} v$

so using this rule, looking at $\frac{1}{n!} e^x \frac{d^n}{dx^n} (x^n e^{-x})$,

$$\text{let } u = x^n$$

$$\text{let } v = e^{-x}$$

$$\text{so } \frac{d^n}{dx^n} (uv) = x^n \frac{d^n}{dx^n} e^{-x} + n \frac{d}{dx} x^n \frac{d^{n-1}}{dx^{n-1}} e^{-x} + \frac{n(n-1)}{2!} \frac{d^2}{dx^2} x^n \frac{d^{n-2}}{dx^{n-2}} e^{-x} + \dots$$

$$+ \frac{d^n}{dx^n} x^n \frac{d^0}{dx^0} e^{-x}$$

now $\frac{d^m}{dx^m} e^{-x} = -e^{-x}$ or $+e^{-x}$. if m is even, then we get

$$+e^{-x}. \text{ if } m \text{ is odd, we get } -e^{-x}. \text{ so } \boxed{\frac{d^m}{dx^m} (e^{-x}) = (-1)^m e^{-x}}$$

$$\text{so } \frac{d^n}{dx^n} (x^n e^{-x}) = x^n e^{-x} - n \left(\frac{d}{dx} x^n \right) e^{-x} + \frac{n(n-1)}{2!} \left(\frac{d^2}{dx^2} x^n \right) e^{-x} - \dots$$

$$+ \frac{d^n}{dx^n} x^n e^{-x}$$

now $\frac{d^m}{dx^m} x^n = n(n-1)(n-2)\dots(n-m+1) x^{n-m}$

for example $\frac{d^3}{dx^3} x^5 = \frac{d^2}{dx^2} (5x^4) = \frac{d}{dx} (5 \cdot 4 \cdot x^3) = 5 \cdot 4 \cdot 3 \cdot x^2$

so $\frac{d^n}{dx^n} (x^n e^{-x}) = x^n e^{-x} - n [n x^{n-1}] e^{-x} + \frac{n(n-1)}{2!} [n(n-1) x^{n-2}] e^{-x} - \dots + \frac{[n(n-1)\dots(1)] x^0}{n!} e^{-x}$

hence $\frac{1}{n!} e^x \left[\frac{d^n}{dx^n} (x^n e^{-x}) \right]$

$= \frac{1}{n!} e^x \left[x^n e^{-x} - n [n x^{n-1}] e^{-x} + \dots + \frac{n!}{n!} [n! x^0] e^{-x} \right]$

here you've taken n derivatives of $e^{-x} \Rightarrow$ so $(-1)^n$

here you haven't taken any derivatives of $e^{-x} \Rightarrow$ so $+$.

$$= \left[\frac{x^n}{n!} - \frac{n}{(n-1)!} x^{n-1} + \frac{n(n-1)}{(n-2)!} x^{n-2} + \dots + (-1)^n \right]$$

Notice depending on if n is even or odd

I can write above as

$$- \frac{x^n}{n!} + \frac{n}{(n-1)!} x^{n-1} - \frac{n(n-1)}{(n-2)!} x^{n-2} + \dots + (-1)^n$$

$$+ \frac{x^n}{n!} - \frac{n}{(n-1)!} x^{n-1} + \dots + (-1)^n$$

the book puts the sign in 22.19 on the last term only.

Ch 12

22.13 using 22.19, verify 22.20 and also find L_3 and L_4 .

$$22.19: L_n(x) = 1 - nx + \frac{n(n-1)}{2!} \frac{x^2}{2!} - \frac{n(n-1)(n-2)}{3!} \frac{x^3}{3!} + \dots + \frac{(-1)^n x^n}{n!}$$

$$= \sum_{m=0}^n (-1)^m \binom{n}{m} \frac{x^m}{m!} \quad \text{Laguerre polynomials.}$$

$$22.20 \quad L_0(x) = 1$$

$$L_1(x) = 1 - x$$

$$L_2(x) = 1 - 2x + \frac{x^2}{2}$$

need to use 22.19 to find 22.20.

for L_0 , put $n=0$ in the sum operation. this results in

$$\boxed{L_0(x) = 1}$$

for L_1 , put $n=1$, we set

$$\sum_{m=0}^1 (-1)^m \binom{1}{m} \frac{x^m}{m!} = (-1)^0 \binom{1}{0} \frac{x^0}{0!} + (-1)^1 \binom{1}{1} \frac{x^1}{1!}$$

$$= \boxed{1 - x} \quad \text{since } \binom{1}{0} = 1.$$

note that $\binom{n}{m} = \frac{n!}{(n-m)! m!}$, and $0! = 1$, $1! = 1$.

For L_2 , put $n=2$. so

$$\sum_{m=0}^2 (-1)^m \binom{2}{m} \frac{x^m}{m!} = (-1)^0 \binom{2}{0} \frac{x^0}{0!} + (-1)^1 \binom{2}{1} \frac{x^1}{1!} + (-1)^2 \binom{2}{2} \frac{x^2}{2!}$$

$$= 1 - \frac{2!}{(2-1)! 1!} x^1 + \frac{2!}{(2-2)! 2!} \frac{x^2}{2!}$$

$$= \boxed{1 - 2x + \frac{x^2}{2}} \quad \text{so all verified}$$

now use 22.19 to find L_3 and L_4

For L_3 , put $n=3$.

$$\text{so } \sum_{m=0}^3 (-1)^m \binom{3}{m} \frac{x^m}{m!} = (-1)^0 \binom{3}{0} \frac{x^0}{0!} + (-1)^1 \binom{3}{1} \frac{x^1}{1!} + (-1)^2 \binom{3}{2} \frac{x^2}{2!} \\ + (-1)^3 \binom{3}{3} \frac{x^3}{3!}$$

$$= 1 - \frac{3!}{(3-1)!1!} x + \frac{3!}{(3-2)!2!} \frac{x^2}{2!} - \frac{3!}{(3-3)!3!} \frac{x^3}{3!}$$

$$= 1 - \frac{3!}{2!} x + \frac{3!}{2!} \frac{x^2}{2!} - \frac{3!}{3!} \frac{x^3}{3!}$$

$$L_3 = \boxed{1 - 3x + \frac{3}{2}x^2 - \frac{x^3}{6}}$$

For L_4 , put $n=4$. we get

$$L_4 = \sum_{m=0}^4 (-1)^m \binom{4}{m} \frac{x^m}{m!} = (-1)^0 \binom{4}{0} \frac{x^0}{0!} + (-1)^1 \binom{4}{1} \frac{x^1}{1!} + (-1)^2 \binom{4}{2} \frac{x^2}{2!} \\ + (-1)^3 \binom{4}{3} \frac{x^3}{3!} + (-1)^4 \binom{4}{4} \frac{x^4}{4!}$$

$$= 1 - \frac{4!}{(4-1)!1!} x + \frac{4!}{(4-2)!2!} \frac{x^2}{2!} - \frac{4!}{(4-3)!3!} \frac{x^3}{3!} + \frac{4!}{(4-4)!4!} \frac{x^4}{4!}$$

$$= 1 - \frac{4!}{3!} x + \frac{4!}{2!2!} \frac{x^2}{2!} - \frac{4!}{3!} \frac{x^3}{3!} + \frac{4!}{4!} \frac{x^4}{4!}$$

$$= 1 - 4x + \frac{4 \times 3 \times 2}{2 \times 2} \frac{x^2}{2} - 4 \frac{x^3}{6} + \frac{x^4}{24}$$

$$L_4 = \boxed{1 - 4x + 3x^2 - \frac{2}{3}x^3 + \frac{x^4}{24}}$$

Ch 12
 22.15 solve the Laguerre DE $xy'' + (1-x)y' + py = 0$
 by power series.

$$\text{let } y = a_0 + a_1x + a_2x^2 + a_3x^3 + a_4x^4 + \dots$$

$$\rightarrow py = pa_0 + pa_1x + pa_2x^2 + pa_3x^3 + \dots$$

$$\rightarrow y' = a_1 + 2a_2x + 3a_3x^2 + 4a_4x^3 + \dots$$

$$\rightarrow -xy' = -a_1x - 2a_2x^2 - 3a_3x^3 - 4a_4x^4 - \dots$$

$$y'' = 2a_2 + 2 \cdot 3 a_3x + 3 \cdot 4 a_4x^2 + \dots$$

$$\rightarrow xy'' = 2a_2x + 2 \cdot 3 a_3x^2 + 3 \cdot 4 a_4x^3 + \dots$$

So table is

	x^0	x^1	x^2	x^3	x^n
py	pa_0	pa_1	pa_2	pa_3	pa_n
y'	a_1	$2a_2$	$3a_3$	$4a_4$	$(n+1)a_{n+1}$
$-xy'$	—	$-a_1$	$-2a_2$	$-3a_3$	$-na_n$
xy''	—	$2a_2$	$2 \cdot 3 a_3$	$3 \cdot 4 a_4$	$n(n+1) a_{n+1}$

from first column, we set

$$\boxed{pa_0 = -a_1} \quad \text{or} \quad \boxed{a_1 = -pa_0}$$

from general recursive formula

$$(n+1)a_{n+1} + n(n+1)a_{n+1} = na_n - pa_n$$

$$(n+1 + n(n+1))a_{n+1} = a_n(n-p)$$

$$a_{n+1} = -a_n \frac{(p-n)}{(n+1) + n(n+1)} = \boxed{\frac{a_n(p-n)}{(n+1)^2}} \rightarrow$$

let me look at few terms

$$\overset{n=1}{a_2} = -\frac{a_1 (P-1)}{4} = -\frac{(P-1)}{4} (-Pa_0) = \frac{P(P-1)}{4} a_0$$

$$\begin{aligned} \overset{n=2}{a_3} &= -\frac{a_2 (P-2)}{9} = -\frac{(P-2)}{9} \left(\frac{P(P-1)}{4} \right) a_0 \\ &= \frac{-P(P-1)(P-2)}{4 \cdot 9} a_0 \end{aligned}$$

$$\begin{aligned} \overset{n=3}{a_4} &= \frac{-a_3 (P-3)}{16} = \frac{-(P-3)}{16} \left(\frac{-P(P-1)(P-2)}{4 \cdot 9} \right) a_0 \\ &= \frac{P(P-1)(P-2)(P-3)}{4 \cdot 9 \cdot 16} a_0 \end{aligned}$$

$$\Rightarrow y = a_0 + a_1 x + a_2 x^2 + a_3 x^3 + a_4 x^4 + \dots$$

$$= a_0 - Pa_0 x + \frac{P(P-1)}{4} a_0 x^2 - \frac{P(P-1)(P-2)}{4 \cdot 9} a_0 x^3 + \frac{P(P-1)(P-2)(P-3)}{4 \cdot 9 \cdot 16} a_0 x^4 + \dots$$

$$= a_0 \left(1 - Px + \frac{P(P-1)}{4} x^2 - \frac{P(P-1)(P-2)}{4 \cdot 9} x^3 + \dots \right)$$

so, if P is an integer, when it is equal to n , the factor $(P-n)$ will become zero, and hence that term, and each term after it (since those will also include the $(P-n)$ factor) will all be zero. hence the a_0 series terminates.



to find L_0, L_1, L_2 and L_3
 set $P=0, 1, 2$, or 3 in the a_0 series and
 stop when we reach the term with $(P-n)$ when
 $n=P$.

$$\text{So from } y = a_0 \left(1 - Px + \frac{P(P-1)}{4} x^2 - \frac{P(P-1)(P-2)}{4 \cdot 9} x^3 + \dots \right)$$

$$\text{for } P=0 \text{ we set } y = a_0 = 1.$$

$$\text{so } L_0(x) = \boxed{1}$$

$$\text{for } P=1 \text{ we set}$$

$$y = a_0(1-x) = \boxed{1-x} \text{ for } a_0=1$$

$$\text{for } P=2, \text{ we set}$$

$$y = a_0 \left(1 - 2x + \frac{2(2-1)}{4} x^2 \right)$$

$$= a_0 \left(1 - 2x + \frac{x^2}{2} \right)$$

$$L_2 = \boxed{1 - 2x + \frac{x^2}{2}} \text{ for } a_0=1$$

$$\text{For } P=3$$

$$L_3 = y = a_0 \left(1 - 3x + \frac{3(3-1)}{4} x^2 - \frac{3(3-1)(3-2)}{4 \cdot 9} x^3 \right)$$

$$= 1 - 3x + \frac{3}{2} x^2 - \frac{13x^2}{24 \times 3} x^3$$

$$= \boxed{1 - 3x + \frac{3}{2} x^2 - \frac{1}{6} x^3}$$

this is an eigenvalue problem, since for different parameter
 of the DE, we find the corresponding solution (eigenfunction)

ch 12

22.18

verify the recursion relation 22.24

$$22.24: L'_{n+1} - L'_n + L_n = 0$$

$$(n+1)L_{n+1} - (2n+1-x)L_n + nL_{n-1} = 0$$

$$xL'_n - nL_n + nL_{n-1} = 0$$

$$\text{from 22.23: } \phi(x, h) = \frac{e^{-xh/(1-h)}}{1-h} = \sum_{n=0}^{\infty} L_n(x) h^n$$

differentiate w.r.t. x

$$\text{so } \frac{\partial \phi}{\partial x} = \frac{1}{1-h} e^{-xh/(1-h)} \left(\frac{-h}{(1-h)} \right) = \sum_{n=0}^{\infty} L'_n(x) h^n$$

$$\frac{\partial \phi}{\partial x} = -\frac{h}{(1-h)^2} e^{-\frac{xh}{1-h}} = \sum_n L'_n h^n$$

$$\frac{\partial \phi}{\partial x} = -\frac{h}{1-h} \frac{e^{-\frac{xh}{1-h}}}{1-h} = \sum_n L'_n h^n$$

ϕ

$$\text{so } \frac{\partial \phi}{\partial x} = -\frac{h}{1-h} \phi = \sum_n L'_n h^n$$

$$\text{ie } h\phi = (h-1) \frac{\partial \phi}{\partial x}$$

so from above I write

$$h \underbrace{\sum L_n h^n}_{\phi} = (h-1) \underbrace{\sum L'_n h^n}_{\frac{\partial \phi}{\partial x}}$$



$$h [L_0 h^0 + L_1 h^1 + L_2 h^2 + \dots] = (h-1) [L'_0 h^0 + L'_1 h^1 + L'_2 h^2 + \dots]$$

$$L_0 h^1 + L_1 h^2 + L_2 h^3 + \dots + L_n h^{n+1} + \dots = L'_0 h^1 + L'_1 h^2 + \dots + L'_n h^{n+1}$$

$$= (L'_0 h^0 + L'_1 h^1 + \dots + L'_n h^n + L'_{n+1} h^{n+1} + \dots)$$

so by equating coefficients of h^{n+1} we have

$$L_n = L'_n - L'_{n+1}$$

$$\text{i.e. } \boxed{L'_{n+1} - L'_n + L_n = 0} \quad \text{which is part (a).}$$

now to find part (b):

differentiate 22.23 w.r.t. h

$$\frac{\partial \phi}{\partial h} = \frac{1}{1-h} e^{-\frac{xh}{1-h}} \left(\frac{d}{dh} \left(\frac{-xh}{1-h} \right) \right) + e^{-\frac{xh}{1-h}} \frac{d}{dh} \left(\frac{1}{1-h} \right) = \sum_{n=0}^{\infty} n h^{n-1} L_n$$

$$\frac{\partial \phi}{\partial h} = \frac{1}{1-h} e^{-\frac{xh}{1-h}} \left(-\left(\frac{x}{1-h} (1) + h \left(-\frac{1}{(1-h)^2} (-1) \right) \right) \right) + e^{-\frac{xh}{1-h}} \left(-\frac{1}{(1-h)^2} (-1) \right) = \downarrow$$

$$\frac{\partial \phi}{\partial h} = \frac{1}{1-h} e^{-\frac{xh}{1-h}} \left(-\left(\frac{x}{1-h} + \frac{h}{(1-h)^2} \right) \right) + e^{-\frac{xh}{1-h}} \left(\frac{1}{(1-h)^2} \right) = \downarrow$$

$$\frac{\partial \phi}{\partial h} = \frac{-1}{1-h} e^{-\frac{xh}{1-h}} \left(\frac{x(1-h) + h}{(1-h)^2} \right) + e^{-\frac{xh}{1-h}} \frac{1}{(1-h)^2} = \downarrow$$

$$= \frac{-e^{-\frac{xh}{1-h}} (x(1-h) + h)}{(1-h)^3} + \frac{e^{-\frac{xh}{1-h}} (1-h)}{(1-h)^3} = \downarrow$$

$$\frac{\partial \phi}{\partial h} = \frac{e^{-\frac{xh}{1-h}} [1-h - x(1-h) - h]}{(1-h)^3} = \sum_{n=0}^{\infty} nh^{n-1} L_n$$

$$= \frac{e^{-\frac{xh}{1-h}} [1-h-x+h-h]}{(1-h)^3} = \downarrow$$

$$\boxed{\frac{\partial \phi}{\partial h} = \frac{e^{-\frac{xh}{1-h}} [1-x-h]}{(1-h)^3} = \sum_{n=0}^{\infty} nh^{n-1} L_n}$$

but $\frac{e^{-\frac{xh}{1-h}}}{1-h} = \phi$ so above can be rewritten as

$$\frac{\partial \phi}{\partial h} = \phi \frac{(1-x-h)}{(1-h)^2} = \sum_{n=0}^{\infty} nh^{n-1} L_n$$

or $\boxed{(1-h)^2 \frac{\partial \phi}{\partial h} = \phi (1-x-h)}$

so $(1-h)^2 \left(\sum_{n=0}^{\infty} nh^{n-1} L_n \right) = \left(\sum_{n=0}^{\infty} L_n h^n \right) [1-x-h]$

$$\text{or } (1-h)^2 [0 + h^0 L_1 + 2h^1 L_2 + 3h^2 L_3 + \dots + (n+1)h^n L_{n+1} + \dots]$$

$$= [L_0 h^0 + L_1 h^1 + \dots + L_n h^n + \dots] [1-x-h]$$

expand and equate coeff of h^n :

$$(1-h)^2 (L_1 + 2hL_2 + 3h^2L_3 + \dots + (n+1)h^nL_{n+1} + \dots)$$

$$= (L_0 + L_1h + \dots + L_nh^n + \dots) (1-x-h)$$

$$(1-2h+h^2) [h^0 L_1 + 2h^1 L_2 + \dots + (n+1)h^n L_{n+1} + \dots]$$

$$= [L_0 h^0 + L_1 h^1 + \dots + L_n h^n + \dots] [1-x-h]$$

$$\left(h^0 L_1 + \dots + (n+1) L_{n+1} h^n + \dots \right) - 2 \left(h^1 L_1 + \dots + (n) h^n L_n + \dots \right) + \left(h^2 L_1 + \dots + (n-1) h^n L_{n-1} + \dots \right)$$

$$= (L_0 h^0 + \dots + L_n h^n + \dots) - (x L_0 h^0 + \dots + x L_n h^n + \dots) - (L_0 h^1 + \dots + L_{n-1} h^n + \dots)$$

So looking at h^n only terms

$$(n+1)L_{n+1} - 2nL_n + (n-1)L_{n-1} = L_n - xL_n - L_{n-1}$$

$$(n+1)L_{n+1} + L_n(-2n-1+x) + L_{n-1}(n-1) = 0$$

$$(n+1)L_{n+1} - L_n(2n+1-x) + L_{n-1}(n) = 0$$

which is part (b).

now to show part (c):

$$(a) \quad h\phi = (h-1) \frac{\partial \phi}{\partial x}$$

$$(b) \quad (1-h-x)\phi = (1-h)^2 \frac{\partial \phi}{\partial h} \quad \longrightarrow$$

$$x \left[\sum L'_n h^n \right] + h \left[\sum L_n h^n \right] - h(1-h) \left[\sum L_n n h^{n-1} \right] = 0$$

pick terms only w/it $h^n \Rightarrow$

$$x \sum L'_n h^n + \left(\sum L_n h^{n+1} \right) - (h+h^2) \left(\sum L_n n h^{n-1} \right) = 0$$

$$x \sum L'_n h^n + \sum L_n h^{n+1} - \sum L_n n h^n + \sum L_n n h^{n+1} = 0$$

so

$$x L'_n + L_{n-1} - n L_n + (n-1) L_{n-1} = 0$$

$$x L'_n + L_{n-1} (1-1+n) - n L_n = 0$$

$$x L'_n - n L_n + n L_{n-1} = 0$$

which is part (c)

QED

Ch 12

22.27

given $f_n(x) = x^{l+1} e^{-\frac{x}{2n}} L_{n-l-1}^{2l+1} \left(\frac{x}{n} \right)$

for $l=1$, show that $f_2(x) = x^2 e^{-x/4}$

$$f_3(x) = x^2 e^{-\frac{x}{6}} \left(4 - \frac{x}{3} \right)$$

$$f_4(x) = x^2 e^{-\frac{x}{8}} \left(10 - \frac{5x}{4} + \frac{x^2}{32} \right)$$

First find L_0^3, L_1^3, L_2^3 .

using 22.25: $L_n^k(x) = (-1)^k \frac{d^k}{dx^k} L_{n+k}(x)$.

$$\text{so } L_0^3 = (-1)^3 \frac{d^3}{dx^3} L_{0+3}(x) = -\frac{d^3}{dx^3} L_3$$

$$\text{but } L_3 = 1 - 3x + \frac{3}{2}x^2 - \frac{x^3}{6}$$

(from problem 22.13
we just did in this
HW set)

$$\begin{aligned} \text{so } L_0^3 &= -\frac{d^3}{dx^3} \left(1 - 3x + \frac{3}{2}x^2 - \frac{x^3}{6} \right) \\ &= -\frac{d^2}{dx^2} \left(-3 + 3x - \frac{3}{2}x^2 \right) \\ &= -\frac{d}{dx} \left(3 - \frac{3}{2}x \right) \\ &= -(-1) = 1 \end{aligned}$$

now, $k=3$, so since $k=2l+1$, then $2l=2$, i.e. $l=1$

so for $n=2$ $f_n(x) = x^{l+1} e^{-\frac{x}{2n}} L_{n-l-1}^{2l+1} \left(\frac{x}{n} \right)$

$$\begin{aligned} \text{i.e. } \boxed{f_2(x)} &= x^2 e^{-\frac{x}{4}} L_{2-1-1}^{2+1} \left(\frac{x}{2} \right) \\ &= x^2 e^{-\frac{x}{4}} L_0^3 \left(\frac{x}{2} \right) \implies \boxed{x^2 e^{-\frac{x}{4}}} \end{aligned}$$

since $L_0^3 = 1$
only.

To find $f_3(x)$. here $n=3$.

$$\begin{aligned} \text{so } f_3(x) &= x^2 e^{-\frac{x}{6}} L_{3-1-1}^3\left(\frac{x}{3}\right) \\ &= x^2 e^{-\frac{x}{6}} L_1^3\left(\frac{x}{3}\right). \quad \text{--- (1)} \end{aligned}$$

now find $L_1^3(x)$, then replace x by $\frac{x}{3}$ in result.

$L_1^3(x)$ is found from 22.25

$$L_n^k(x) = (-1)^k \frac{d^k}{dx^k} L_{n+k}(x)$$

$$\text{so } L_1^3(x) = (-1)^3 \frac{d^3}{dx^3} L_{3+1}(x) = -\frac{d^3}{dx^3} L_4(x).$$

$$\text{But } L_4(x) = 1 - 4x + 3x^2 - \frac{2}{3}x^3 + \frac{x^4}{24} \quad (\text{from 22.13}).$$

$$\begin{aligned} \text{so } L_1^3(x) &= -\frac{d^2}{dx^2} \left(-4 + 6x - 2x^2 + \frac{4x^3}{24} \right) \\ &= -\frac{d}{dx} \left(6 - 4x + \frac{3x^2}{6} \right) \end{aligned}$$

$$= -(-4 + \frac{2x}{2}) = -(-4 + x) = \boxed{4 - x}$$

$$\text{so } \boxed{L_1^3\left(\frac{x}{3}\right) = 4 - \left(\frac{x}{3}\right)}$$

so from (1) above

$$\boxed{f_3(x) = x^2 e^{-\frac{x}{6}} \left(4 - \frac{x}{3}\right)}$$

→

now to find $f_4(x)$.

here $n=4$, so

$$f_4(x) = x^2 e^{-\frac{x}{8}} L_{4-1-1}^3\left(\frac{x}{4}\right)$$

$$= x^2 e^{-\frac{x}{8}} L_2^3\left(\frac{x}{4}\right).$$

find $L_2^3(x)$ from 22.25, and replace result x by $\frac{x}{4}$:

from 22.25

$$L_n^k(x) = (-1)^k \frac{d^k}{dx^k} L_{n+k}(x)$$

$$\text{so } L_2^3(x) = (-1)^3 \frac{d^3}{dx^3} L_5(x).$$

need to find $L_5(x)$ first. (using 22.19)

$$L_5(x) = \sum_{m=0}^5 (-1)^m \binom{5}{m} \frac{x^m}{m!}$$

$$L_5(x) = (-1)^0 \binom{5}{0} \frac{x^0}{1} + (-1)^1 \binom{5}{1} \frac{x}{1!} + (-1)^2 \binom{5}{2} \frac{x^2}{2!} + (-1)^3 \binom{5}{3} \frac{x^3}{3!} + (-1)^4 \binom{5}{4} \frac{x^4}{4!}$$

$$+ (-1)^5 \binom{5}{5} \frac{x^5}{5!}$$

$$= 1 - \frac{5!}{(5-1)! 1!} x + \frac{5!}{(5-2)! 2!} \frac{x^2}{2!} - \frac{5!}{(5-3)! 3!} \frac{x^3}{3!} + \frac{5!}{(5-4)! 4!} \frac{x^4}{4!}$$

$$- \frac{5!}{5!} \frac{x^5}{5!}$$

$$= 1 - \frac{5!}{4!} x + \frac{5!}{3! 2!} \frac{x^2}{2!} - \frac{5!}{2! 3!} \frac{x^3}{3!} + \frac{5!}{4!} \frac{x^4}{4!} - \frac{x^5}{5!}$$

$$= 1 - \frac{120}{24} x + \frac{120}{6 \times 2} \frac{x^2}{2} - \frac{120}{2 \times 6} \frac{x^3}{6} + \frac{120}{24} \frac{x^4}{24} - \frac{x^5}{120}$$

$$L_5(x) = 1 - 5x + 5x^2 - \frac{120}{2 \times 36} x^3 + \frac{120}{576} x^4 - \frac{x^5}{120}$$

$$L_5(x) = 1 - 5x + 5x^2 - \frac{10}{6} x^3 + \frac{15}{72} x^4 - \frac{x^5}{120}$$

So now can find $L_2^3(x)$.

$$L_2^3 = -\frac{d^3}{dx^3} L_5(x)$$

$$= -\frac{d^2}{dx^2} \left(-5 + 10x - \frac{10x^2}{2} + \frac{4 \times 15}{72} x^3 - \frac{5x^4}{120} \right)$$

$$= -\frac{d}{dx} \left(10 - 10x + \frac{3 \times 4 \times 15}{72} x^2 - \frac{5 \times 4 x^3}{120} \right)$$

$$= - \left(-10 + \frac{2 \cdot 3 \cdot 4 \cdot 15}{72 \cdot 369} x - \frac{3 \cdot 5 \cdot 4 x^2}{120 \cdot 36182} \right)$$

$$L_2^3 = 10 - \frac{3 \cdot 15}{9} x + \frac{x^2}{2}$$

now replace x by $\left(\frac{x}{4}\right)$. \Rightarrow

$$L_2^3 = 10 - 5 \left(\frac{x}{4}\right) + \frac{1}{2} \left(\frac{x}{4}\right)^2$$

$$L_2^3 = 10 - \frac{5}{4} x + \frac{x^2}{32}$$

$$\text{So } f_4(x) = x^2 e^{-\frac{x}{8}} \left(10 - \frac{5}{4} x + \frac{x^2}{32} \right)$$

now to proof the orthogonality \rightarrow

to show f_2, f_3, f_4 are orthogonal over $(0, \infty)$,
 need to show that $\int_0^{\infty} f_a f_b dx = 0$

for each combination. i.e. $(f_2, f_3), (f_2, f_4), (f_3, f_4)$.

for f_2, f_3

$$\begin{aligned} \int_0^{\infty} f_2 f_3 dx &= \int_0^{\infty} x^2 e^{-\frac{x}{4}} x^2 e^{-\frac{x}{6}} \left(4 - \frac{x}{3}\right) dx \\ &= \int_0^{\infty} x^4 e^{-\frac{x}{4} - \frac{x}{6}} \left(4 - \frac{x}{3}\right) dx \\ &= \int_0^{\infty} x^4 e^{\frac{-6x - 4x}{24}} \left(4 - \frac{x}{3}\right) dx = \int_0^{\infty} x^4 e^{-\frac{10x}{24}} \left(4 - \frac{x}{3}\right) dx \\ &= 4 \int_0^{\infty} x^4 e^{-\frac{5}{12}x} dx - \frac{1}{3} \int_0^{\infty} x^5 e^{-\frac{5}{12}x} dx \end{aligned}$$

need to use Γ integral, which is $\Gamma(p) = \int_0^{\infty} x^{p-1} e^{-x} dx$

so let $\boxed{\frac{5}{12}x = u}$, so $\frac{5}{12} dx = du$ or $\boxed{dx = \frac{12}{5} du}$

and $x = \frac{12}{5}u$. so $x^4 = \left(\frac{12}{5}u\right)^4 = \left(\frac{12}{5}\right)^4 u^4$

when $x=0$, $u=0$

when $x=\infty$, $u=\infty$. hence integrals are

$$= 4 \int_0^{\infty} \left(\frac{12}{5}\right)^4 u^4 e^{-u} \left(\frac{12}{5}\right) du - \frac{1}{3} \int_0^{\infty} \left(\frac{12}{5}\right)^5 u^5 e^{-u} \left(\frac{12}{5}\right) du \rightarrow$$

$$\begin{aligned}
&= 4 \left(\frac{12}{5}\right)^4 \left(\frac{12}{5}\right) \int_0^{\infty} u^4 e^{-u} du - \frac{1}{3} \left(\frac{12}{5}\right)^5 \left(\frac{12}{5}\right) \int_0^{\infty} u^5 e^{-u} du \\
&= 4 \left(\frac{12}{5}\right)^5 \left[\Gamma(4+1) \right] - \frac{1}{3} \left(\frac{12}{5}\right)^6 \left[\Gamma(5+1) \right] \\
&= 4 \left(\frac{12}{5}\right)^5 4! - \frac{1}{3} \left(\frac{12}{5}\right)^6 5! \\
&= \left(\frac{12}{5}\right)^5 \left[4 \times 4! - \frac{1}{3} \left(\frac{12}{5}\right) 5! \right] \\
&= \left(\frac{12}{5}\right)^5 \left[4(4 \cdot 3 \cdot 2) - \frac{4}{5} (5 \cdot 4 \cdot 3 \cdot 2) \right] \\
&= \left(\frac{12}{5}\right)^5 \left[4(4 \cdot 3 \cdot 2) - 4(4 \cdot 3 \cdot 2) \right] = 0
\end{aligned}$$

hence this shows f_2, f_3 are orthogonal over $(0, \infty)$.

using similar steps f_2, f_4 and f_3, f_4 can be shown to be orthogonal. I do not think there need to be done as nothing new needs to be shown. it will be just same steps as above.

□

ch 13

1.1 Assume from electrostatics the equation $\nabla \cdot \bar{D} = \rho$

and $\bar{D} = -\epsilon \nabla \phi$, show that electrostatic potential satisfies Laplace equation in charge free region and satisfies Poisson's equation in region with charge density ρ .

Laplace equation $\nabla^2 u = 0$

Poisson's equation $\nabla^2 u = f(x, y, z)$.

In a charge free region, $\rho = 0$. i.e. $\nabla \cdot \bar{D} = 0$

so $\nabla \cdot (-\epsilon \nabla \phi) = 0$

$$\left(\frac{\partial}{\partial x} \bar{i} + \frac{\partial}{\partial y} \bar{j} + \frac{\partial}{\partial z} \bar{k} \right) \cdot \left(-\epsilon \left(\bar{i} \frac{\partial \phi}{\partial x} + \bar{j} \frac{\partial \phi}{\partial y} + \bar{k} \frac{\partial \phi}{\partial z} \right) \right) = 0$$

$$\text{so } -\epsilon \left(\frac{\partial^2 \phi}{\partial x^2} + \frac{\partial^2 \phi}{\partial y^2} + \frac{\partial^2 \phi}{\partial z^2} \right) = 0$$

$$\text{i.e. } \boxed{\frac{\partial^2 \phi}{\partial x^2} + \frac{\partial^2 \phi}{\partial y^2} + \frac{\partial^2 \phi}{\partial z^2} = 0} \quad \text{since } \epsilon \neq 0.$$

this is Laplace equation.

In region with charge density ρ , we have

$$\nabla \cdot \bar{D} = \rho(x, y, z) \rightarrow \text{density is assumed a function of position. i.e. it can change depending on part of region we are in.}$$

$$\text{so } \nabla \cdot (-\epsilon \nabla \phi(x, y, z)) = \rho(x, y, z)$$

$$\Rightarrow -\epsilon \left(\frac{\partial^2 \phi}{\partial x^2} + \frac{\partial^2 \phi}{\partial y^2} + \frac{\partial^2 \phi}{\partial z^2} \right) = \rho(x, y, z)$$

$$\text{i.e. } \frac{\partial^2 \phi}{\partial x^2} + \frac{\partial^2 \phi}{\partial y^2} + \frac{\partial^2 \phi}{\partial z^2} = -\frac{\rho(x, y, z)}{\epsilon} = f(x, y, z).$$

this is Poisson's equation.

QED.

Ch 13

1.2

show that the expression $u = \sin(x-vt)$ describing a sinusoidal wave satisfies the wave equation.

Show that in general $u = f(x-vt)$ and $u = f(x+vt)$ satisfy the wave equation 1.4 where f is any function with a second derivative.

$$\text{wave equation } \nabla^2 u = \frac{1}{v^2} \frac{\partial^2 u}{\partial t^2}$$

to show that $u = \sin(x-vt)$ satisfy wave equation, sub into the wave equation:

$$\frac{\partial u}{\partial x} = \cos(x-vt)$$

$$\frac{\partial u}{\partial t} = \cos(x-vt) (-v)$$

$$\frac{\partial^2 u}{\partial x^2} = -\sin(x-vt)$$

$$\frac{\partial^2 u}{\partial t^2} = -\sin(x-vt) (v^2)$$

$$\text{so } \boxed{\frac{\partial^2 u}{\partial x^2} = \frac{1}{v^2} \frac{\partial^2 u}{\partial t^2}}$$

which is the wave equation

if $u = f(x+vt)$, then

$$\frac{\partial u}{\partial x} = f'$$

$$\frac{\partial u}{\partial t} = f' v$$

$$\frac{\partial^2 u}{\partial x^2} = f''$$

$$\frac{\partial^2 u}{\partial t^2} = f'' v^2$$

$$\text{so } \boxed{\frac{\partial^2 u}{\partial x^2} = \frac{1}{v^2} \frac{\partial^2 u}{\partial t^2}}$$

for $u = f(x-vt)$, we set

$$\frac{\partial u}{\partial x} = f'$$

$$\frac{\partial u}{\partial t} = -v f'$$

$$\frac{\partial^2 u}{\partial x^2} = f''$$

$$\frac{\partial^2 u}{\partial t^2} = v^2 f''$$

$$\boxed{\frac{\partial^2 u}{\partial x^2} = \frac{1}{v^2} \frac{\partial^2 u}{\partial t^2}}$$

QED.

ch 13

1.3

Assume from electricity the following equations which are valid in free space.

$$\begin{aligned}\bar{\nabla} \cdot \bar{E} &= 0 & \bar{\nabla} \cdot \bar{H} &= 0 \\ \bar{\nabla} \times \bar{E} &= -\mu \frac{\partial \bar{H}}{\partial t}, & \bar{\nabla} \times \bar{H} &= \epsilon \frac{\partial \bar{E}}{\partial t}\end{aligned}$$

from them show that any component of \bar{E} or \bar{H} satisfies the wave equation (1.4) with $v = (\epsilon\mu)^{-1/2}$.

wave equation is $\nabla^2 u = \frac{1}{v^2} \frac{\partial^2 u}{\partial t^2}$

identity (c) is $\bar{\nabla} \times (\bar{\nabla} \times \bar{v}) = \bar{\nabla}(\bar{\nabla} \cdot \bar{v}) - \nabla^2 \bar{v}$

in $\bar{\nabla} \times \bar{H} = \epsilon \frac{\partial \bar{E}}{\partial t}$, let $v = (\epsilon\mu)^{-1/2}$, so $v^2 = \frac{1}{\epsilon\mu}$

i.e. $\epsilon = \frac{1}{\mu v^2}$, so $\boxed{\bar{\nabla} \times \bar{H} = \frac{1}{\mu v^2} \frac{\partial \bar{E}}{\partial t}}$

so $\begin{pmatrix} \bar{i} & \bar{j} & \bar{k} \\ \frac{\partial}{\partial x} & \frac{\partial}{\partial y} & \frac{\partial}{\partial z} \\ H_x & H_y & H_z \end{pmatrix} = \frac{1}{\mu v^2} \left(\bar{i} \frac{\partial E_x}{\partial t} + \bar{j} \frac{\partial E_y}{\partial t} + \bar{k} \frac{\partial E_z}{\partial t} \right)$

$i \left(\frac{\partial H_z}{\partial y} - \frac{\partial H_y}{\partial z} \right) - \bar{j} \left(\frac{\partial H_z}{\partial x} - \frac{\partial H_x}{\partial z} \right) + \bar{k} \left(\frac{\partial H_y}{\partial x} - \frac{\partial H_x}{\partial y} \right) = \frac{1}{\mu v^2} \left(\right)$

so $\frac{\partial H_z}{\partial y} - \frac{\partial H_y}{\partial z} = \frac{1}{\mu v^2} \frac{\partial E_x}{\partial t}$

$\frac{\partial H_z}{\partial x} - \frac{\partial H_x}{\partial z} = \frac{1}{\mu v^2} \frac{\partial E_y}{\partial t}$

$\frac{\partial H_y}{\partial x} - \frac{\partial H_x}{\partial y} = \frac{1}{\mu v^2} \frac{\partial E_z}{\partial t}$

Sorry, do not see how to continue with this problem.

4.8 HW 8

Local contents

4.8.1	Chapter 13, problem 2.1 Mary Boas book. Second edition	192
4.8.2	Chapter 13, problem 2.2 Mary Boas book. second edition	197
4.8.3	Chapter 13, problem 2.3 Mary Boas book. second edition	201
4.8.4	Chapter 13, problem 2.7 Mary Boas book. second edition.	205
4.8.5	Chapter 13, problem 3.2 Mary Boas book. second edition	209
4.8.6	Chapter 13, problem 3.3 Mary Boas book. second edition	213
4.8.7	Chapter 13, problem 3.7. Mary Boas book. second edition	217
4.8.8	Chapter 13, problem 3.9. Mary Boas book. second edition	222
4.8.9	Problem chapter 13, 3.10. Mary Boas book. Second edition	225

4.8.1 Chapter 13, problem 2.1 Mary Boas book. Second edition

Find the steady-state temperature distribution for the semi-infinite plate problem if the temp at the bottom edge is $T = f(x) = x$ (in degrees; that is the temp at x cm is x degrees). The temperature of the others sides is zero degrees and the width of the plate is 10 cm.

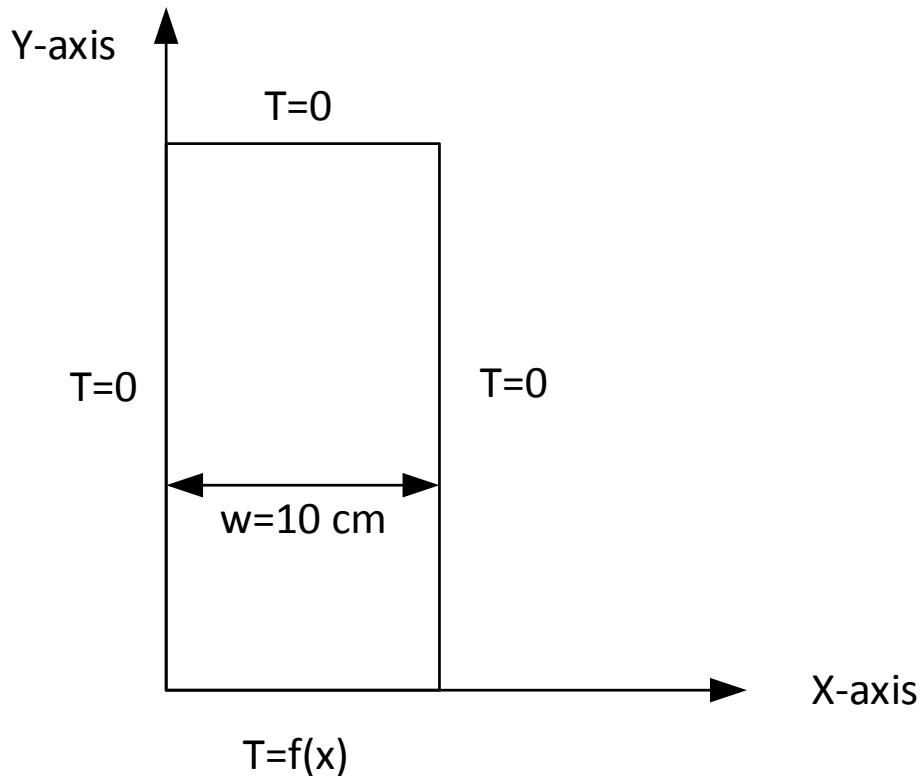

Semi-infinite plate

Solution

Since we are looking for a steady state heat distribution, which means there is no heat source, then we use Laplace PDE to represent the problem. We need to solve the following PDE

$$\nabla^2 T = \frac{\partial^2 T}{\partial x^2} + \frac{\partial^2 T}{\partial y^2} = 0$$

For a 2D problem as the above, we start by assuming that the solution $T(x, y)$ is of the form $T(x, y) = X(x)Y(y)$. We now substitute this assumed solution into the Laplace PDE and obtain

$$X''Y + Y''X = 0$$

dividing by XY gives

$$\begin{aligned}\frac{1}{X}X'' + Y''\frac{1}{Y} &= 0 \\ \frac{1}{X}X'' &= -\frac{1}{Y}Y'' = -k^2\end{aligned}$$

Since the left hand side in the above equation depends only on the independent variable x while the right hand side depends only on the independent variable y , and both sides are equal to each others, then each side must be equal to the same constant. This is called the separation of variables approach. Assuming this constant is $-k^2$ for $k \geq 0$ we obtain two ODE's to solve for X and Y

$$X'' + k^2X = 0$$

and

$$Y'' - k^2Y = 0$$

To solve the X ODE, we assume the solution is $X = Ae^{mx}$, for some constants A, m and substitute this in the ODE to obtain $m^2Ae^{mx} + k^2Ae^{mx} = 0$, or $m^2 + k^2 = 0$. This is the characteristic equation whose solution is $m = \pm ik$, hence $X = Ae^{\pm ikx}$.

A general solution is found by adding all the individual solutions, hence $X = Ae^{ikx} + Ae^{-ikx} = A(e^{ikx} + e^{-ikx})$. But $\cos(kx) = \frac{e^{ikx} + e^{-ikx}}{2}$, hence $X = 2A \cos(kx) = \cos(kx)$ by taking constant $2A = 1$.

Another general solution can be obtained by taking the difference of the individual solutions, hence, $X = Ae^{ikx} - Ae^{-ikx} = A(e^{ikx} - e^{-ikx})$. But $\sin kx = \frac{e^{ikx} - e^{-ikx}}{2i}$, hence $X = 2iA \sin kx = \sin(kx)$ by taking $2iA = 1$. Therefore solutions to $\frac{1}{X} \frac{d^2X}{dx^2} = -k^2$ are

$$X_1(x) = \cos(kx)$$

$$X_2(x) = \sin(kx)$$

Now we solve $Y'' - k^2Y = 0$. Assuming solution is $Y = Ae^{my}$ hence the characteristic equation is $m^2Ae^{my} - k^2Ae^{my} = 0$, or $m^2 - k^2 = 0$, hence $m = \pm k$, then $Y = Ae^{\pm ky}$, and let $A = 1$, then $Y = e^{-ky}$ or $Y = e^{ky}$

Since $T(x, y) = X(x)Y(y)$, then the T solution is a combination of all the above solutions.

$$T(x, y) = \begin{cases} \sin kx \\ \cos kx \end{cases} \begin{cases} e^{ky} \\ e^{-ky} \end{cases}$$

Now we use the boundary conditions on the plate to find which of the above 4 solutions is the correct solution.

Since this is a semi-infinite plate, then as $y \rightarrow \infty$, $T(x, y) \rightarrow 0$, this means e^{ky} solution must be rejected since they have the positive power of y on the exponential function. (since $k > 0$). Therefore we now have

$$T(x, y) = \begin{cases} \sin kx e^{-ky} \\ \cos kx e^{-ky} \end{cases}$$

Looking now at the left boundary condition where we want $T = 0$ for $x = 0$, this means that solution $\cos kx e^{-ky}$ must be rejected since it is not zero at $x = 0$.

So, only solution left is

$$T(x, y) = \sin kx e^{-ky}$$

And we have two boundary conditions to satisfy yet, the right hand side, and the bottom side.

At the right side, where $x = w = 10 \text{ cm}$, we need $T = 0$, hence this can be achieved by having $\sin 10k = 0$ or $10k = n\pi$, or $k = \frac{n\pi}{10}$ for $n = 1, 2, 3, \dots$ So the solution now looks like

$$T(x, y) = \sin\left(\frac{n\pi}{10}x\right)e^{-\frac{n\pi}{10}y} \quad n = 1, 2, 3, \dots$$

We have the last boundary condition to satisfy, which is the bottom side. On that side we have $T = f(x) = x$ at $y = 0$ hence if we let $y = 0$ in the above the solution becomes

$$T(x, 0) = x = \sin\left(\frac{n\pi}{10}x\right)$$

This solution is not satisfied for any n . for example, for $x = 5$, $n = 1$, we have $\sin\left(\frac{\pi}{10}5\right) = \sin \frac{\pi}{2} = 1 \neq 5$

Hence we need to find another method to find this boundary condition. Since a sum of scaled solutions is also a solution (this is a linear system), then we write

$$T(x, y) = \sum_{n=1}^{\infty} b_n e^{-\frac{n\pi}{10}y} \sin\left(\frac{n\pi}{10}x\right)$$

Now we try to find b_n when $y = 0$. This is the Fourier series expansion for $f(x)$.

Since sin functions are orthogonal to each others, i.e. $\int_0^w \sin ax \sin bx \, dx = 0$ $a \neq b$, the

above can be written as

$$\begin{aligned} \int_0^w \sin\left(\frac{n\pi}{10}x\right) f(x) dx &= \int_0^{10} \sin\left(\frac{n\pi}{10}x\right) \left(\sum_{m=1}^{\infty} b_m \sin\left(\frac{m\pi}{10}x\right)\right) dx \\ &= \sum_{m=1}^{\infty} b_m \int_0^{10} \sin\left(\frac{n\pi}{10}x\right) \sin\left(\frac{m\pi}{10}x\right) dx \\ &= b_n \int_0^{10} \sin\left(\frac{n\pi}{10}x\right) \sin\left(\frac{n\pi}{10}x\right) dx \end{aligned}$$

Since all terms vanish except when $m = n$ then

$$\begin{aligned} b_n &= \frac{\int_0^{10} \sin\left(\frac{n\pi}{10}x\right) f(x) dx}{\int_0^{10} \sin^2\left(\frac{n\pi}{10}x\right) dx} \\ &= \frac{\int_0^{10} \sin\left(\frac{n\pi}{10}x\right) x dx}{\int_0^{10} \sin^2\left(\frac{n\pi}{10}x\right) dx} \end{aligned}$$

But $\int_0^{10} \sin^2\left(\frac{n\pi}{10}x\right) dx = 5$ for $n \neq 0$. Hence $b_n = \frac{2}{10} \int_0^{10} x \sin\left(\frac{n\pi}{10}x\right) dx$. integration by parts.
 $\int u dv dx = uv - \int v \frac{du}{dx} dx$. Let $u = x$, $dv = \sin\left(\frac{n\pi}{10}x\right)$ then $\frac{du}{dx} = 1$, $v = \frac{-w}{n\pi} \cos\left(\frac{n\pi}{10}x\right)$. Hence (using $w = 10$)

$$\begin{aligned} \frac{b_n}{2} &= \left[-x \frac{w}{n\pi} \cos\left(\frac{n\pi}{w}x\right) \right]_0^w - \int_0^w \frac{-w}{n\pi} \cos\left(\frac{n\pi}{w}x\right) dx \\ &= \left[\frac{-w^2}{n\pi} \cos(n\pi) - 0 \right] + \frac{w}{n\pi} \left[\frac{1}{\frac{n\pi}{w}} \sin \frac{n\pi}{w} x \right]_0^w \\ &= \left[\frac{-w^2}{n\pi} \cos(n\pi) \right] + \frac{w}{n\pi} \left[\frac{w}{n\pi} \sin n\pi - 0 \right] \\ &= \left[\frac{-w^2}{n\pi} \cos(n\pi) \right] + \left[\frac{w^2}{n^2\pi^2} \sin n\pi \right] \\ &= \frac{w^2}{\pi} \left(\frac{-1}{n} \cos(n\pi) + \frac{1}{n^2\pi} \sin n\pi \right) \end{aligned}$$

Hence

$$b_n = 2 \frac{w}{\pi} \left(\frac{-1}{n} \cos(n\pi) + \frac{1}{n^2\pi} \sin n\pi \right)$$

Since n is an integer, all the $\sin n\pi$ terms vanish

$$b_n = 2 \frac{w}{\pi} \left(\frac{-1}{n} \cos(n\pi) \right)$$

Since $w = 10$ then

$$b_n = \frac{20}{\pi} \left(\frac{-1}{n} \cos(n\pi) \right)$$

Then

$$\begin{aligned} b_n &= \frac{20}{\pi} \left(\frac{-1}{1}(-1) \right), \frac{20}{\pi} \left(\frac{-1}{2}(1) \right), \frac{20}{\pi} \left(\frac{-1}{3}(-1) \right), \dots \\ b_n &= \frac{20}{\pi}, \frac{20}{\pi} \left(\frac{-1}{2} \right), \frac{20}{\pi} \left(\frac{+1}{3} \right), \dots \\ &= \frac{20}{\pi} \left(\frac{-1^{n+1}}{n} \right) \end{aligned}$$

Hence

$$\begin{aligned} T(x, y) &= \sum_{n=1}^{\infty} b_n e^{-\frac{n\pi}{10}y} \sin\left(\frac{n\pi}{10}x\right) \\ T(x, y) &= \frac{20}{\pi} \sum_{n=1}^{\infty} \left(\frac{-1^{n+1}}{n} \right) e^{-\frac{n\pi}{10}y} \sin\left(\frac{n\pi}{10}x\right) \end{aligned}$$

Here is a plot of the solution for n up to 70.

```
L0 = 2; a = .2;
T0[x_, t_, m_] := 100 - 400/Pi Sum[(-1)^n/(2 n + 1)
Exp[-(a (2 n + 1)/2 Pi/L0)^2 t] Cos[(2 n + 1)/2 Pi/L0 x], {n, 0, m, 1}];
p = Plot3D[T0[x, t, 50], {x, 0, L0}, {t, 0, 10}, PlotRange -> All,
AxesLabel -> {x, "sec", u}, BaseStyle -> 15]
```

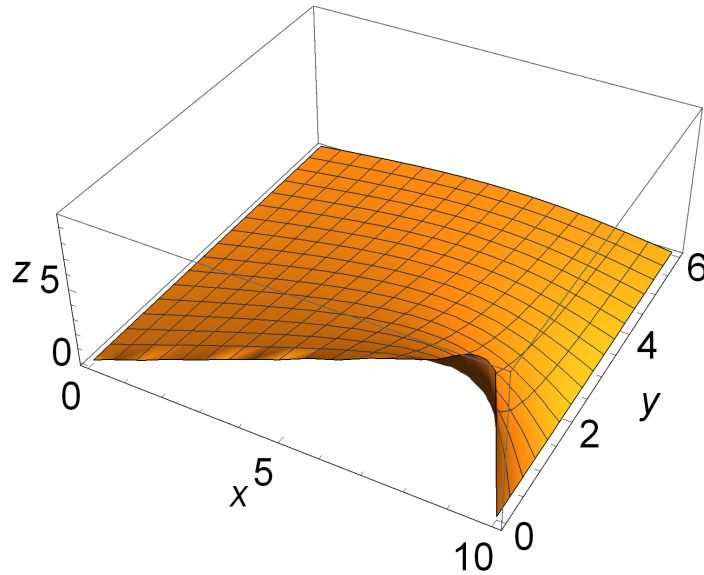



4.8.2 Chapter 13, problem 2.2 Mary Boas book. second edition

Find the steady-state temperature distribution for the semi-infinite plate with bottom edge of 20 cm if the temp at the bottom edge temp. is held at

$$T = \begin{cases} 0^{\circ} & 0 < x < 10 \\ 100 & 10 < x < 20 \end{cases}$$

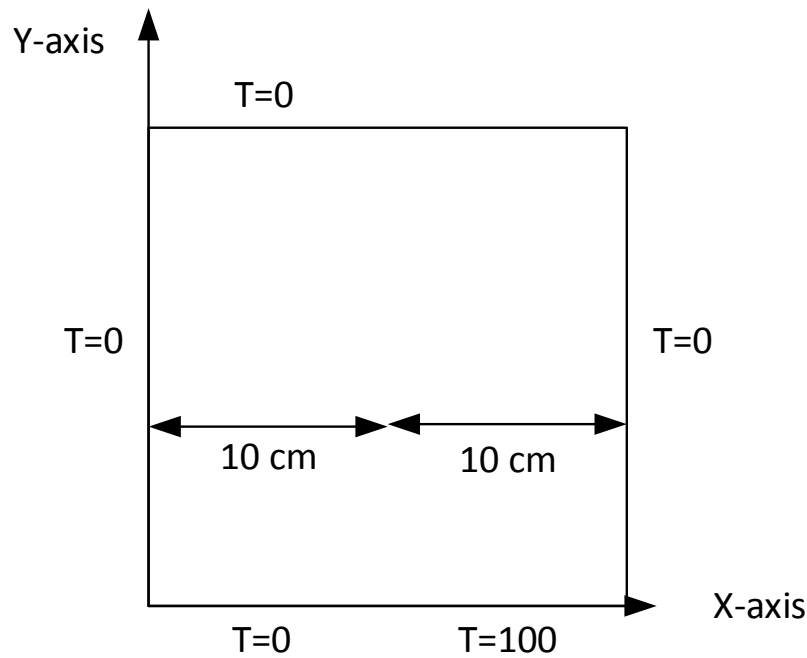
The others sides at zero degrees.



Semi-infinite plate

solution To solve this, I will follow the same steps as in 2.1, until I get to the step of trying to fit to the bottom edge conditions into the solution, and then I will use $f(x)$ as a step function:

$$f(x) = \begin{cases} 0 & 0 < x < 10 \\ 100 & 10 < x < 20 \end{cases}$$

Hence, as shown in problem 2.1, the candidate solutions for $T(x, y)$ are

$$T(x, y) = \begin{cases} \sin kx e^{ky} \\ \sin kx e^{-ky} \\ \cos kx e^{ky} \\ \cos kx e^{-ky} \end{cases}$$

Now we use the boundary conditions on the plate to find which of the above 4 solutions is the correct solution. We know by the uniqueness theorem of ODE solution that there will be one solution only out of the above 4, and by the existence theorem, that a solution will exist.

Since this is a semi-infinite plate, then as $y \rightarrow \infty$, $T(x, y) \rightarrow 0$, this means $\sin(kx)e^{ky}$ and $\cos(kx)e^{ky}$ solution must be rejected since they have the positive power of y on the exponential function. (since $k > 0$)

Looking now at the left boundary condition where we want $T = 0$ for $x = 0$, this means that solution $\cos(kx)e^{-ky}$ must be rejected since it is not zero at $x = 0$.

So, only solution left is $\sin(kx)e^{-ky}$ and we have 2 boundary conditions to satisfy yet, the right hand side, and the bottom side.

At the right side, where $x = w = 20 \text{ cm}$, we need $T = 0$, hence this can be achieved by having $kw = n\pi$, or $k = \frac{n\pi}{w}$ for $n = 1, 2, 3, \dots$

so the solution now looks like

$$T(x, y) = \sin\left(\frac{n\pi}{w}x\right) e^{-\frac{n\pi}{w}y} \quad n = 1, 2, 3, \dots$$

Now we have the last boundary condition to satisfy, Since a sum of scaled solutions is also a solution (this is a linear system), then we write

$$T(x, y) = \sum_{n=1}^{\infty} b_n e^{-\frac{n\pi}{w}y} \sin\left(\frac{n\pi}{w}x\right)$$

And now we try to find b_n when $y = 0$

This is the Fourier series expansion for $f(x)$.

Since sin functions are orthogonal to each others, i.e. $\int_0^w \sin ax \sin(bx) dx = 0$ for $a \neq b$ then the above can be written as

$$\begin{aligned} \int_0^w \sin\left(\frac{n\pi}{w}x\right) f(x) dx &= \int_0^w \sin\left(\frac{n\pi}{w}x\right) \left(\sum_{m=1}^{\infty} b_m \sin\left(\frac{m\pi}{w}x\right)\right) dx \\ &= \sum_{m=1}^{\infty} b_m \int_0^w \sin\left(\frac{n\pi}{w}x\right) \sin\left(\frac{m\pi}{w}x\right) dx \\ &= b_n \int_0^w \sin\left(\frac{n\pi}{w}x\right) \sin\left(\frac{n\pi}{w}x\right) dx \end{aligned}$$

Since all terms vanish expect when $m = n$, hence

$$\begin{aligned} b_n &= \frac{\int_0^w \sin\left(\frac{n\pi}{w}x\right) f(x) dx}{\int_0^w \sin^2\left(\frac{n\pi}{w}x\right) dx} \\ &= \frac{\int_0^w \sin\left(\frac{n\pi}{w}x\right) x dx}{\int_0^w \sin^2\left(\frac{n\pi}{w}x\right) dx} \end{aligned}$$

But $\int_0^w \sin^2\left(\frac{n\pi}{w}x\right) dx = \frac{w}{2}$ for $n \neq 0$ Hence

$$\begin{aligned} b_n &= \frac{2}{w} \int_0^w f(x) \sin\left(\frac{n\pi}{w}x\right) dx \\ &= \frac{2}{20} \left\{ \int_0^{10} f(x) \sin\left(\frac{n\pi}{w}x\right) dx + \int_{10}^{20} f(x) \sin\left(\frac{n\pi}{w}x\right) dx \right\} \end{aligned}$$

But $f(x) = 0$ for $0 < x < 10$, and $f(x) = 100$ for $10 < x < 20$ therefore

$$\begin{aligned} b_n &= \frac{2}{20} \left\{ \int_0^{10} 0 \sin\left(\frac{n\pi}{20}x\right) dx + \int_{10}^{20} 100 \sin\left(\frac{n\pi}{20}x\right) dx \right\} \\ &= \frac{200}{20} \int_{10}^{20} \sin\left(\frac{n\pi}{20}x\right) dx \\ &= 10 \int_{10}^{20} \sin\left(\frac{n\pi}{20}x\right) dx \\ &= 10 \frac{1}{\frac{n\pi}{20}} \left[-\cos \frac{n\pi}{20}x \right]_{10}^{20} \\ &= \frac{-200}{n\pi} \left[\cos \frac{n\pi}{20}x \right]_{10}^{20} \\ &= \frac{-200}{n\pi} \left[\cos \frac{n\pi}{20}20 - \cos \frac{n\pi}{20}10 \right] \\ &= \frac{-200}{n\pi} \left[\cos n\pi - \cos \frac{n\pi}{2} \right] \end{aligned}$$

Looking at few n values starting from $n = 1$

$$\begin{aligned} b_n &= \frac{-200}{\pi} \left[\cos \pi - \cos \frac{\pi}{2} \right], \frac{-200}{2\pi} \left[\cos 2\pi - \cos \pi \right], \frac{-200}{3\pi} \left[\cos 3\pi - \cos \frac{3\pi}{2} \right], \frac{-200}{4\pi} \left[\cos 4\pi - \cos 2\pi \right], \\ &\frac{-200}{5\pi} \left[\cos 5\pi - \cos \frac{5\pi}{2} \right], \frac{-200}{6\pi} \left[\cos 6\pi - \cos 3\pi \right], \frac{-200}{7\pi} \left[\cos 7\pi - \cos \frac{7\pi}{2} \right], \frac{-200}{8\pi} \left[\cos 8\pi - \cos 4\pi \right] \end{aligned}$$

$$\begin{aligned} b_n &= \frac{-200}{\pi} [-1 - 0], \frac{-200}{2\pi} [1 - (-1)], \frac{-200}{3\pi} [-1 - 0], \frac{-200}{4\pi} [1 - 1], \frac{-200}{5\pi} [-1 - 0], \frac{-200}{6\pi} [1 - (-1)], \\ &\frac{-200}{7\pi} [-1 - 0], \frac{-200}{8\pi} [1 - 1] \end{aligned}$$

$$b_n = \frac{-200}{\pi} [-1], \frac{-200}{2\pi} [2], \frac{-200}{3\pi} [-1], \frac{-200}{4\pi} [0], \frac{-200}{5\pi} [-1], \frac{-200}{6\pi} [2], \frac{-200}{7\pi} [-1], \frac{-200}{8\pi} [0], \dots$$

We see a term multiplier is $-1, 2, -1, 0, -1, 2, -1, 0, \dots$

When n is multiple of 4, this multiplier is zero. when n is odd, the multiplier is -1 , and when n is even (not multiple of 4), this multiplier is 2 .

Solution is

$$T(x, y) = \sum_{n=1}^{\infty} b_n e^{-\frac{n\pi}{20}y} \sin\left(\frac{n\pi}{20}x\right)$$

$$T(x, y) = \begin{cases} \frac{200}{\pi} \sum_n \frac{1}{n} e^{-\frac{n\pi}{20}y} \sin\left(\frac{n\pi}{20}x\right) & n \text{ odd, } 1, 3, 5, 7, \dots \\ -\frac{400}{\pi} \sum_n \frac{1}{n} e^{-\frac{n\pi}{20}y} \sin\left(\frac{n\pi}{20}x\right) & n \text{ even } 2, 6, 10, 14, 18, \dots \\ 0 & \text{Otherwise} \end{cases}$$

```
L0 = 2; a = .2;
T0[x_, t_, m_] := 100 - 400/Pi Sum[(-1)^n/(2 n + 1)
Exp[-(a (2 n + 1)/2 Pi/L0)^2 t] Cos[(2 n + 1)/2 Pi/L0 x], {n, 0, m, 1}];
p = Plot3D[T0[x, t, 50], {x, 0, L0}, {t, 0, 10}, PlotRange -> All,
AxesLabel -> {x, "sec", u}, BaseStyle -> 15]
```

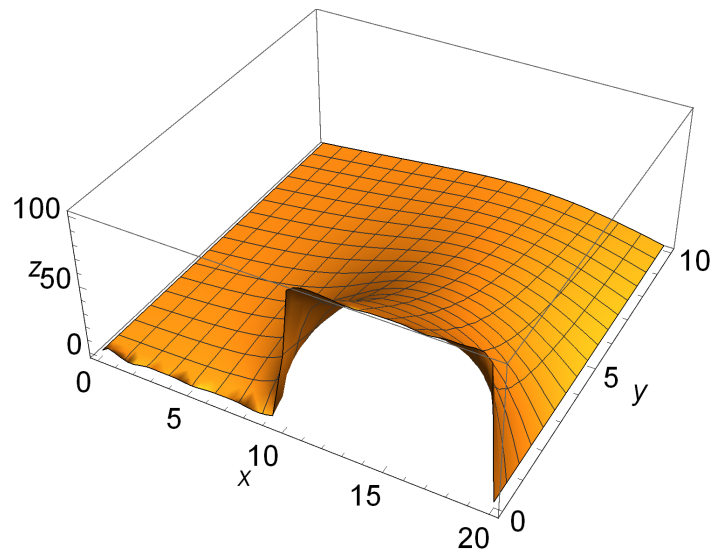

4.8.3 Chapter 13, problem 2.3 Mary Boas book. second edition

Find the steady-state temperature distribution for the semi-infinite plate problem if the temp at the bottom edge is $T = f(x) = \cos(x)$ (The temp. of the others sides is zero degrees, and the width of the plate is π cm.

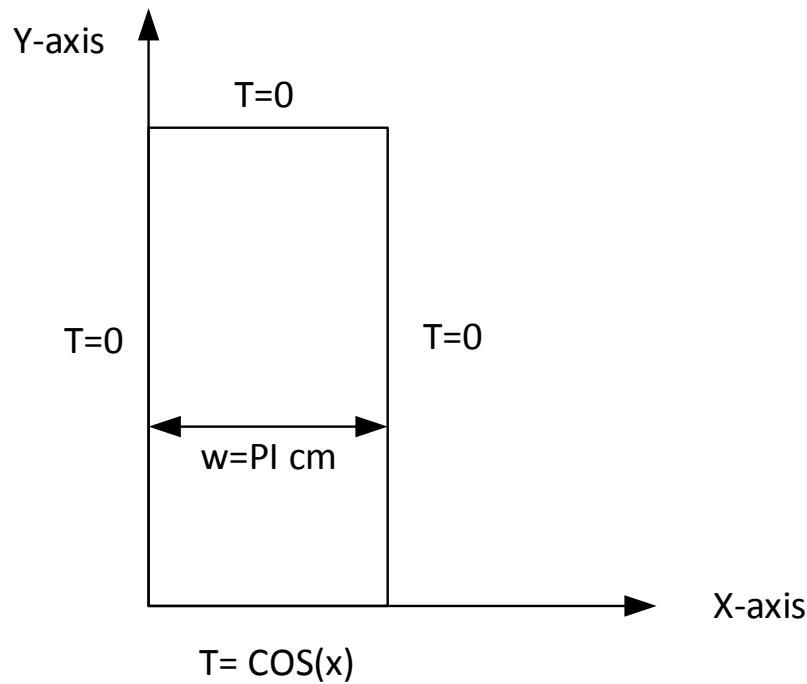

Semi-infinite plate

Solution

This problem is similar to problem 2.1, but for a different boundary function at the bottom edge.

As shown in problem 2.1, $T(x, y)$ is given by one of these solutions:

$$T(x, y) = \begin{cases} \sin kx e^{ky} \\ \sin kx e^{-ky} \\ \cos kx e^{ky} \\ \cos kx e^{-ky} \end{cases}$$

Now we use the boundary conditions on the plate to find which of the above 4 solutions is the correct solution. We know by the uniqueness theorem of ODE solution that there will be one solution only out of the above 4, and by the existence theorem, that a solution will exist.

Since this is a semi-infinite plate, then as $y \rightarrow \infty$, $T(x, y) \rightarrow 0$, this means $\sin kx e^{ky}$ and $\cos kx e^{ky}$ solution must be rejected since they have the positive power of y on the exponential function. (since $k > 0$)

Looking now at the left boundary condition where we want $T = 0$ for $x = 0$, this means that solution $\cos kx e^{-ky}$ must be rejected since it is not zero at $x = 0$.

Only solution left is $\sin kx e^{-ky}$ and we have 2 boundary conditions to satisfy yet, the right hand side, and the bottom side.

At the right side, where $x = w = \pi \text{ cm}$, we need $T = 0$, hence this can be achieved by having $k\pi = n\pi$, or $k = n$ for $n = 1, 2, 3, \dots$

so the solution now looks like

$$T(x, y) = \sin(nx) e^{-ny} \quad n = 1, 2, 3, \dots$$

Now we have the last boundary condition to satisfy, which is the bottom side. On that side we have $T = f(x) = \cos(x)$ at $y = 0$ hence if we let $y = 0$ in the above the solution becomes

$$T(x, y) = \cos(x) = \sin(nx)$$

This solution is not satisfied for any n .

Hence we need to find another method to find this boundary condition. Since a sum of scaled solutions is also a solution (this is a linear system), then we write

$$T(x, y) = \sum_{n=1}^{\infty} b_n e^{-ny} \sin(nx)$$

Now we try to find b_n when $y = 0$, i.e. at $y = 0$

$$T(x, y) = f(x) = \cos(x) = \sum_{n=1}^{\infty} b_n \sin(nx)$$

This is the Fourier series expansion for $f(x)$. Since sin functions are orthogonal to each others, i.e. $\int_0^{\pi} \sin ax \sin bx \, dx = 0$ $a \neq b$, the above can be written as (taking inner product of RHS and LHS w.r.t. $\sin(nx)$):

$$\begin{aligned} \cos(x) &= \sum_{n=1}^{\infty} b_n \sin(nx) \\ \int_0^{\pi} \sin(nx) f(x) \, dx &= \int_0^{\pi} \sin(nx) \left(\sum_{m=1}^{\infty} b_m \sin(mx) \right) dx \\ \int_0^{\pi} \sin(nx) \cos(x) \, dx &= \sum_{m=1}^{\infty} b_m \int_0^{\pi} \sin(nx) \sin(mx) dx \\ \int_0^{\pi} \sin(nx) \cos(x) \, dx &= b_n \int_0^{\pi} \sin(nx) \sin(nx) dx \end{aligned}$$

Where on the RHS we simplified it since all terms vanish except when $m = n$. The above now becomes

$$\int_0^\pi \sin(nx) \cos(x) dx = b_n \int_0^\pi \sin^2(nx) dx$$

$$\int_0^\pi \sin(nx) \cos(x) dx = b_n \frac{\pi}{2}$$

$$b_n = \frac{2}{\pi} \int_0^\pi \sin(nx) \cos(x) dx$$

$$= \frac{2}{\pi} \frac{n(1 + \cos(n\pi))}{n^2 - 1}$$

Looking at few values of $n = 2, 3, 4, \dots$ (not defined for $n=1$).

$$b_n = \frac{2}{\pi} \frac{2(1 + \cos(2\pi))}{3}, \frac{2}{\pi} \frac{3(1 + \cos(3\pi))}{8}, \frac{2}{\pi} \frac{4(1 + \cos(4\pi))}{15}, \dots$$

$$b_n = \frac{2}{\pi} \frac{2(2)}{3}, 0, \frac{2}{\pi} \frac{4(2)}{8}, 0, \dots$$

$$= \frac{4}{\pi} \frac{n}{n^2 - 1} \text{ for even } n$$

Since

$$T(x, y) = \sum_{n=1}^{\infty} b_n e^{-ny} \sin(nx)$$

Then the final solution is

$$T(x, y) = \frac{4}{\pi} \sum_{n=\text{even}}^{\infty} \frac{n}{n^2 - 1} e^{-ny} \sin(nx)$$

```
L0 = 2; a = .2;
T0[x_, t_, m_] := 100 - 400/Pi Sum[(-1)^n/(2 n + 1)
Exp[-(a (2 n + 1)/2 Pi/L0)^2 t] Cos[(2 n + 1)/2 Pi/L0 x], {n, 0, m, 1}];
p = Plot3D[T0[x, t, 50], {x, 0, L0}, {t, 0, 10}, PlotRange -> All,
AxesLabel -> {x, "sec", u}, BaseStyle -> 15]
```

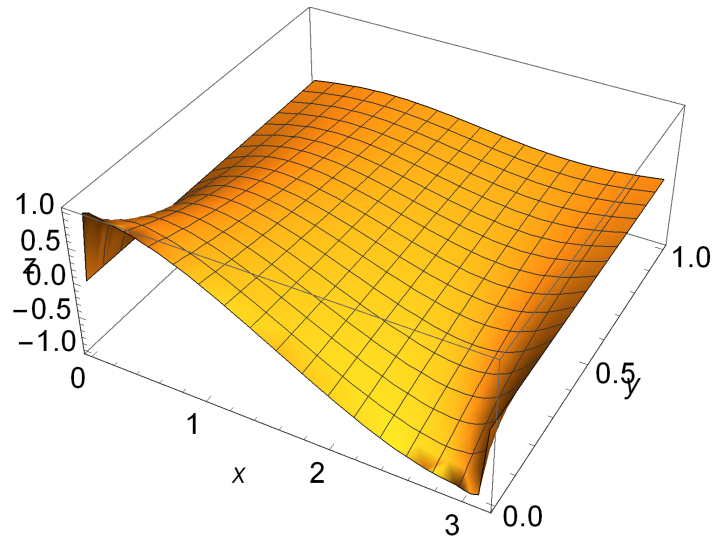
4.8.4 Chapter 13, problem 2.7 Mary Boas book. second edition.

Find the steady-state temperature distribution of the following plate, height=1. Temp at the bottom edge is $T = \cos(x)$ (The temp. of the others sides is zero degree and width of the plate is π cm.

Y-axis

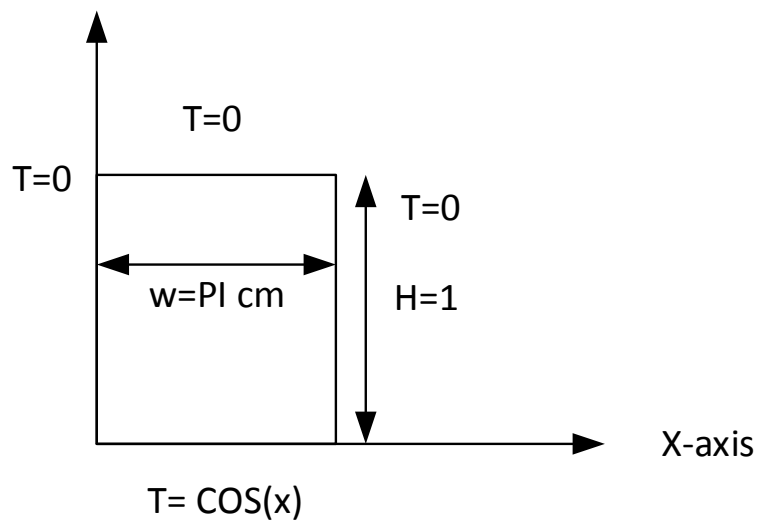

Solution As shown in problem 2.1, $T(x, y)$ is given by one of these solutions:

$$T(x, y) = \begin{cases} \sin kx e^{ky} \\ \sin kx e^{-ky} \\ \cos kx e^{ky} \\ \cos kx e^{-ky} \end{cases}$$

Now we use the boundary conditions on the plate to find which of the above 4 solutions is the correct solution. We know by the uniqueness theorem of ODE solution that there will be one solution only out of the above 4, and by the existence theorem, that a solution will exist.

Here we can not reject the 2 candidate solutions $\sin kx e^{ky}$ and $\cos kx e^{ky}$ as we did for the semi-infinite plate cases because as $y \rightarrow 1$, these solutions do not blow up.

But to use one of them, looking at $T(x, y) = \sin kx e^{ky}$, then at $y = 1$, where we require $T = 0$, we get $0 = \sin kx$, and this means we must have $k = n\pi$ for integer n . but this means that $T = 0$ everywhere in the plate and on the other boundaries, which is not correct.

Similarly if we try to fit $\cos(kx)e^{ky}$.

One way to avoid this problem is to use a linear combination of the exponential $ae^{-ky} + be^{ky}$ and now we try to find a, b . If we choose $a = \frac{1}{2}e^{hk}, b = -\frac{1}{2}e^{-hk}$, where h is the height of the plate, we get

$$\frac{1}{2}e^{hk}e^{-ky} - \frac{1}{2}e^{-hk}e^{ky} = \frac{1}{2}e^{k(h-y)} - \frac{1}{2}e^{-k(h-y)}$$

To verify, We want $\frac{1}{2}e^{k(h-y)} - \frac{1}{2}e^{-k(h-y)} = 0$ when $y = h$, Hence

$$\frac{1}{2}e^{k(h-y)} - \frac{1}{2}e^{-k(h-y)} = \frac{1}{2} - \frac{1}{2} = 0$$

The solutions to consider are now

$$T(x, y) = \begin{cases} \sin kx \left(\frac{1}{2}e^{k(h-y)} - \frac{1}{2}e^{-k(h-y)} \right) \\ \cos kx \left(\frac{1}{2}e^{k(h-y)} - \frac{1}{2}e^{-k(h-y)} \right) \end{cases}$$

The initial 4 candidate solutions are now 2 candidate solutions since we have combined a combination of two solutions together.

Looking now at the left boundary condition where we want $T = 0$ for $x = 0$, this means the second candidate solution above which is $\cos kx \left(\frac{1}{2}e^{k(h-y)} - \frac{1}{2}e^{-k(h-y)} \right)$ must be rejected since it is not zero at $x = 0$ for any y .

Only solution left is $\sin kx \left(\frac{1}{2}e^{k(h-y)} - \frac{1}{2}e^{-k(h-y)} \right)$. Write $\frac{1}{2}e^{k(h-y)} - \frac{1}{2}e^{-k(h-y)} = \sinh k(h-y)$ then the final candidate solution which we want to fit on the remaining boundary conditions can be written as

$$T(x, y) = \sinh k(h-y) \sin(kx)$$

We have 2 boundary conditions to satisfy yet, the right hand side, and the bottom side. At the right side, where $x = w = \pi cm$, we need

$$T = 0 = \sinh k(h-y) \sin k\pi$$

hence this can be achieved by having $k\pi = n\pi$, or $k = n$ for $n = 1, 2, 3, \dots$ So the solution now looks like

$$T(x, y) = \sinh n(h-y) \sin(nx) \quad n = 1, 2, 3, \dots$$

Now we have the last boundary condition to satisfy, which is the bottom side. On that side we have $T = f(x) = \cos(x)$ at $y = 0$ hence if we let $y = 0$ in the above the solution becomes

$$T(x, y) = \cos(x) = \sinh(n(h)) \sin(nx)$$

This solution is not satisfied for any n . We need to find another method to find this boundary condition. Since a sum of scaled solutions is also a solution (this is a linear system), then we write

$$T(x, y) = \sum_{n=1}^{\infty} b_n \sinh(n(h-y)) \sin(nx)$$

And now we try to find b_n when $y = 0$, i.e. at $y = 0$

$$T(x, y) = f(x) = \cos(x) = \sum_{n=1}^{\infty} b_n \sinh(nh) \sin(nx)$$

This is the Fourier series expansion for $f(x)$. Since sin functions are orthogonal to each others, i.e.

$$\int_0^{\pi} \sin(ax) \sin(bx) dx = 0 \quad a \neq b$$

The above can be written as (taking inner product of RHS and LHS w.r.t. $\sin nx$) :

$$\begin{aligned}\cos(x) &= \sum_{m=1}^{\infty} b_m \sinh(mh) \sin(mx) \\ \int_0^{\pi} \sin(nx) f(x) dx &= \int_0^{\pi} \sin(nx) \left(\sum_{m=1}^{\infty} b_m \sinh(mh) \sin(mx) \right) dx \\ \int_0^{\pi} \sin(nx) \cos(x) dx &= \sum_{m=1}^{\infty} b_m \int_0^{\pi} \sin(nx) \sinh(mh) \sin(mx) dx \\ \int_0^{\pi} \sin(nx) \cos(x) dx &= b_n \int_0^{\pi} \sin(nx) \sinh(nh) \sin(nx) dx\end{aligned}$$

Where on the RHS we simplified it since all terms vanish except when $m = n$. Above now becomes

$$\begin{aligned}\int_0^{\pi} \sin(nx) \cos(x) dx &= b_n \int_0^{\pi} \sinh(nh) \sin^2(nx) dx \\ \int_0^{\pi} \sin(nx) \cos(x) dx &= \sinh(nh) b_n \int_0^{\pi} \sin^2(nx) dx \\ &= \frac{\pi}{2} b_n \sinh(nh)\end{aligned}$$

$$\begin{aligned}b_n &= \frac{2}{\pi} \frac{1}{\sinh(nh)} \int_0^{\pi} \sin(nx) \cos(x) dx \\ &= \frac{2}{\pi} \frac{1}{\sinh(nh)} \frac{n(1 + \cos(n\pi))}{n^2 - 1}\end{aligned}$$

Looking at few values of $n = 2, 3, 4, \dots$ (not defined for $n=1$).

$$\begin{aligned}b_n &= \frac{2}{\pi} \frac{1}{\sinh(h)} \frac{2(1 + \cos(2\pi))}{3}, \frac{2}{\pi} \frac{1}{\sinh(2h)} \frac{3(1 + \cos(3\pi))}{8}, \frac{1}{\sinh(2h)} \frac{2}{\pi} \frac{4(1 + \cos(4\pi))}{15} \dots \\ b_n &= \frac{2}{\pi} \frac{1}{\sinh(h)} \frac{2(2)}{3}, 0, \frac{1}{\sinh(3h)} \frac{2}{\pi} \frac{4(2)}{8}, 0, \dots \\ &= \frac{4}{\pi} \frac{1}{\sinh(nh)} \frac{n}{n^2 - 1} \text{ for even } n\end{aligned}$$

Since

$$T(x, y) = \sum_{n=1}^{\infty} b_n \sinh(n(h - y)) \sin(nx)$$

The final solution becomes

$$T(x, y) = \frac{4}{\pi} \sum_{n=\text{even}}^{\infty} \frac{1}{\sinh(nh)} \frac{n}{n^2 - 1} \sinh(n(h - y)) \sin(nx)$$

```
L0 = 2; a = .2;
T0[x_, t_, m_] := 100 - 400/Pi Sum[(-1)^n/(2 n + 1)
Exp[-(a (2 n + 1)/2 Pi/L0)^2 t] Cos[(2 n + 1)/2 Pi/L0 x], {n, 0, m, 1}];
p = Plot3D[T0[x, t, 50], {x, 0, L0}, {t, 0, 10}, PlotRange -> All,
AxesLabel -> {x, "sec", u}, BaseStyle -> 15]
```

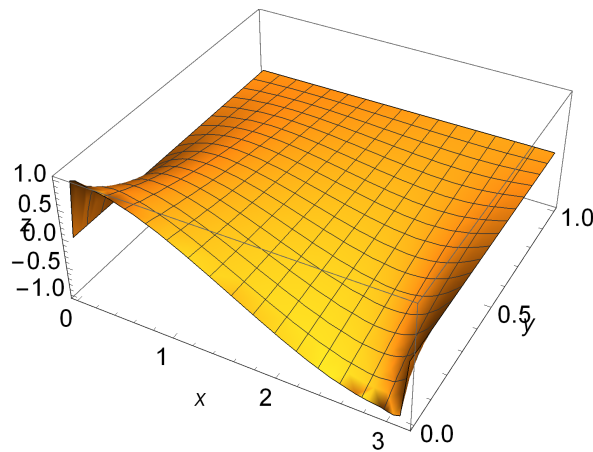

4.8.5 Chapter 13, problem 3.2 Mary Boas book. second edition

A bar length $L=10$ cm with insulated sides is initially at 100 degrees. starting at $t=0$, the ends are held at zero degree. Find the temperature distribution in the bar at time t .

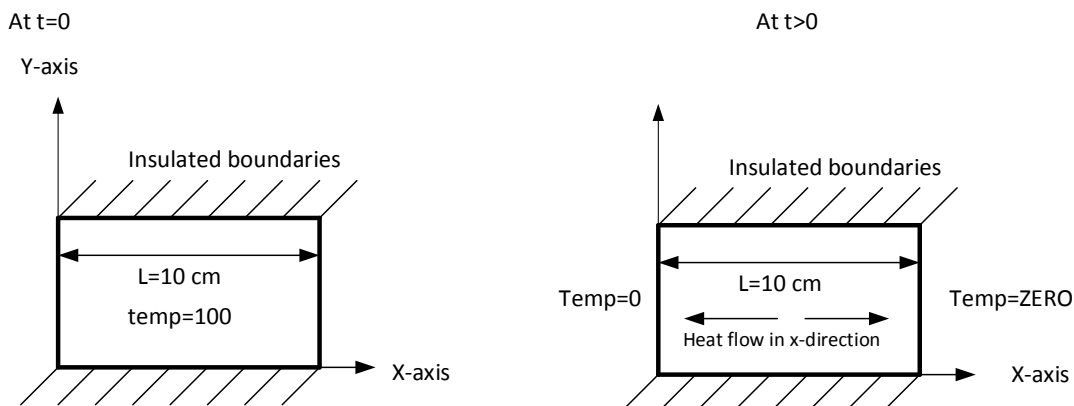

Solution

This is a heat distribution problem governed by the diffusion or heat equation

$$\nabla^2 u(x, t) = \frac{1}{\alpha^2} \frac{\partial u(x, t)}{\partial t}$$

This is for a one spatial dimension.

To solve this PDE, assume the solution is

$$u(x, t) = F(x)T(t)$$

Where $F(x)$ is a function of the spatial x independent variable, and $T(t)$ is a function of the time t .

Solving using separation of variable as with the Laplace equation. By substituting in the original PDE, we get

$$\frac{1}{F} \frac{d^2 F}{dx^2} = \frac{1}{\alpha^2} \frac{1}{T} \frac{dT}{dt}$$

Since RHS and LHS are both equal, and each is a function of a different independent variable, then both must be equal to a constant. Let this constant be $-k^2$. hence we get 2 ODE equations to solve

$$\begin{aligned} \frac{1}{F} \frac{d^2 F}{dx^2} &= -k^2 \\ \frac{1}{T} \frac{1}{\alpha^2} \frac{dT}{dt} &= -k^2 \end{aligned}$$

To solve $\frac{1}{T} \frac{1}{\alpha^2} \frac{dT(t)}{dt} = -k^2$,

$$\begin{aligned} \frac{1}{T} \frac{dT}{dt} &= -\alpha^2 k^2 \\ \frac{1}{T} dT &= -\alpha^2 k^2 dt \\ \int \frac{1}{T} dT &= \int -\alpha^2 k^2 dt \\ \ln T &= -\alpha^2 k^2 t \\ T &= e^{-\alpha^2 k^2 t} \end{aligned}$$

To solve $\frac{1}{F} \frac{d^2 F}{dx^2} = -k^2$. Assume solution is $F(x) = e^{-mx}$ then $\frac{dF}{dx} = -me^{-mx}$, $\frac{d^2 F}{dx^2} = m^2 e^{-mx}$. Substituting in the ODE gives $m^2 e^{-mx} = -e^{-mx} k^2$ or $m^2 = -k^2$, $m = \pm ik$, so $F(x) = e^{-ikx}$ or

$F(x) = e^{ikx}$. By adding or subtracting these solutions we get a general solution that is either $\cos kx$ or $\sin kx$.

hence

$$F(x) = \begin{cases} \sin kx \\ \cos kx \end{cases}$$

So

$$u(x, t) = F(x)T(t)$$

$$u(x, t) = \begin{cases} e^{-\alpha^2 k^2 t} \sin kx \\ e^{-\alpha^2 k^2 t} \cos kx \end{cases}$$

Now we have 2 candidate solutions. Since these are solutions for $t > 0$, we need to find the conditions that $u = 0$ at $x = 0$ and $x = L$.

Since at $x = 0$, $u = 0$, then we can not use the $\cos kx$, solution because that will not go to zero at $x = 0$.

So we are left with the solution

$$u(x, t) = e^{-\alpha^2 k^2 t} \sin kx$$

Now apply the second boundary condition, which is $x = L, u = 0$.

This means $0 = e^{-\alpha^2 k^2 t} \sin kL$, then $kL = n\pi$ or $K = \frac{n\pi}{L}$ for $n = 1, 2, 3, \dots$. So our solution now looks like

$$u(x, t) = e^{-\alpha^2 \left(\frac{n\pi}{L}\right)^2 t} \sin \frac{n\pi}{L} x \quad n = 1, 2, 3, \dots$$

Since a scaled sum of these solutions is a solution, then the general solution is

$$u(x, t) = \sum_{n=1}^{\infty} b_n e^{-\alpha^2 \left(\frac{n\pi}{L}\right)^2 t} \sin \frac{n\pi}{L} x \quad (1)$$

Now we need to find the b_n

For this we use the initial conditions, i.e. for $t = 0$. Then we had the sides at $u = 100$, and since no time was involved then (this is the initial steady state), the governing PDE is the Laplace equation with only the x spatial coordinate.

$\nabla^2 u_0(x) = 0$, a solution to this is $u_0(x) = ax + b$. when $x = 0$, $u_0 = 100$, hence $100 = b$.

When $x = L$, $u = 100$, hence $100 = La + b$, or $La = 100 - 100 = 0$. hence $a = 0$.

Hence at $t = 0$, $u_0 = 100$. So now from equation (1) above, we write

$$u(x, 0) = u_0(x) = 100 = \sum_{n=1}^{\infty} b_n \sin \frac{n\pi}{L} x$$

Taking the inner product of the LHS and RHS w.r.t. $\sin \frac{n\pi x}{L}$ over $[0, L]$ gives

$$\begin{aligned} \int_0^L 100 \sin \frac{n\pi}{L} x dx &= \int_0^L \left(\sum_{m=1}^{\infty} b_m \sin \frac{m\pi}{L} x \right) \sin \frac{n\pi}{L} x dx \\ 100 \int_0^L \sin \frac{n\pi}{L} x dx &= \sum_{m=1}^{\infty} b_m \int_0^L \sin \frac{m\pi}{L} x \sin \frac{n\pi}{L} x dx \\ 100 \int_0^L \sin \frac{n\pi}{L} x dx &= b_n \int_0^L \sin^2 \frac{n\pi}{L} x dx \\ -100 \left[\frac{L}{n\pi} \cos \frac{n\pi x}{L} \right]_0^L &= b_n \frac{L}{2} \\ -100 \left[\frac{L}{n\pi} \cos n\pi - \frac{L}{n\pi} \right] &= b_n \frac{L}{2} \\ -\frac{100L}{n\pi} [\cos n\pi - 1] &= b_n \frac{L}{2} \\ b_n &= -\frac{200}{n\pi} [\cos n\pi - 1] \end{aligned}$$

Looking at few values of $n = 1, 2, 3, 4, \dots$, $b_n = -\frac{200}{n\pi} [\cos n\pi - 1]$

$$\begin{aligned} b_n &= -\frac{200}{\pi} [\cos \pi - 1], -\frac{200}{2\pi} [\cos 2\pi - 1], -\frac{200}{3\pi} [\cos 3\pi - 1], -\frac{200}{4\pi} [\cos 4\pi - 1], \dots \\ b_n &= -\frac{200}{\pi} [-1 - 1], -\frac{200}{2\pi} [1 - 1], -\frac{200}{3\pi} [-1 - 1], -\frac{200}{4\pi} [1 - 1], \dots \\ b_n &= \frac{400}{\pi}, 0, \frac{400}{3\pi}, 0, \end{aligned}$$

Hence

$$b_n = \frac{1}{n} \frac{400}{\pi} \quad \text{for odd } n$$

From equation (1) above we had

$$u(x, t) = \sum_{n=1}^{\infty} b_n e^{-a^2 \left(\frac{n\pi}{L}\right)^2 t} \sin \frac{n\pi}{L} x$$

Hence

$$u(x, t) = \frac{400}{\pi} \sum_{\text{odd } n} \frac{1}{n} e^{-a^2 \left(\frac{n\pi}{L}\right)^2 t} \sin\left(\frac{n\pi}{L} x\right)$$

```
L0 = 2; a = .2;
T0[x_, t_, m_] := 100 - 400/Pi Sum[(-1)^n/(2 n + 1)
Exp[-(a (2 n + 1)/2 Pi/L0)^2 t] Cos[(2 n + 1)/2 Pi/L0 x], {n, 0, m, 1}];
p = Plot3D[T0[x, t, 50], {x, 0, L0}, {t, 0, 10}, PlotRange -> All,
AxesLabel -> {x, "sec", u}, BaseStyle -> 15]
```

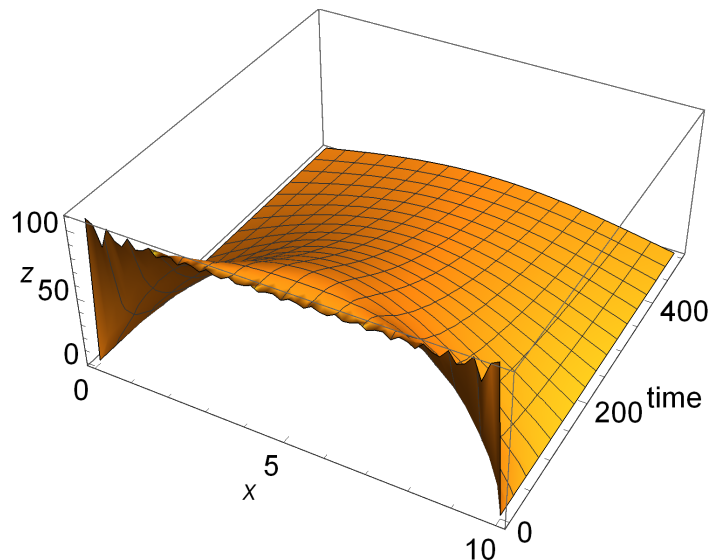

4.8.6 Chapter 13, problem 3.3 Mary Boas book. second edition

In the initial state of an infinite slab of thickness L , the face $x=0$ is at zero degrees, and the face at $x = l$ is at 100 degrees. from $t = 0$ on, the face at $x = 0$ is held at 100 degrees, and the face at $x = L$ at zero degrees. find the temp. distribution at time t .

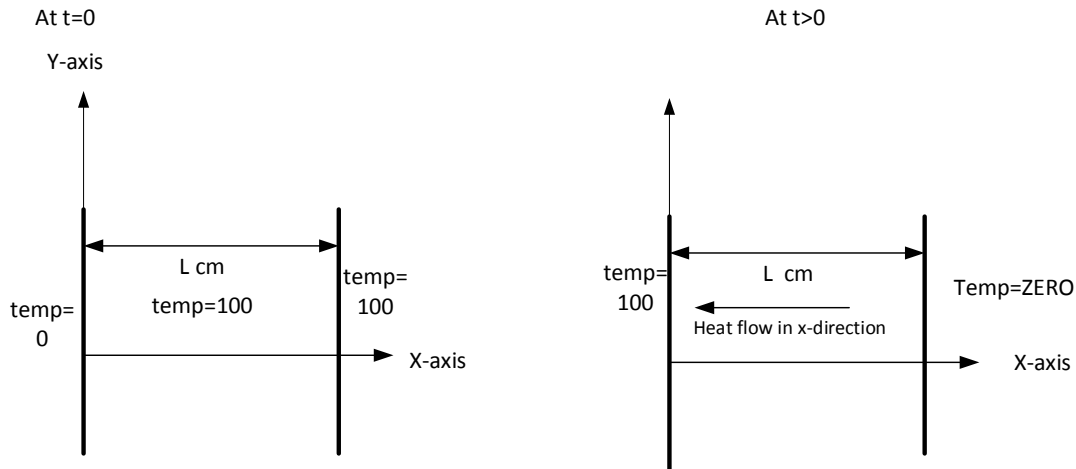

Solution

This is a heat distribution problem governed by the diffusion or heat equation

$$\nabla^2 u(x, t) = \frac{1}{\alpha^2} \frac{\partial u(x, t)}{\partial t}$$

This problem is similar to problem 2.2, where an infinite slab is considered the same as a slab with 2 insulated sides. Similar to problem 3.2, we get the following 2 candidate solutions to the above PDE

$$u(x, t) = \begin{cases} e^{-\alpha^2 k^2 t} \sin kx \\ e^{-\alpha^2 k^2 t} \cos kx \end{cases}$$

Since these are solutions for $t > 0$, we need to find the conditions that $u = 100$ at $x = 0$ and $u = 0$ at $x = L$.

discard the $\cos kx$ solution because at $x = 0$ we want $u = 100$, which means $e^{-\alpha^2 k^2 t} \cos kx = e^{-\alpha^2 k^2 t} = 100$ which is not generally true for all t .

So the second solution is $e^{-\alpha^2 k^2 t} \sin kx$, which is 0 at $x = L$, hence $e^{-\alpha^2 k^2 t} \sin kL = 0$, i.e. $kL = n\pi$ or $k = \frac{n\pi}{L}$. So we start with the solution

$$u(x, t) = e^{-\alpha^2 \left(\frac{n\pi}{L}\right)^2 t} \sin \frac{n\pi}{L} x$$

To make this solution fit at $x = 0$, we need to have $100 = e^{-\alpha^2 k^2 t} \sin \frac{n\pi}{L} x$. but $\sin(x)$ is zero at $x = 0$, hence to compensate, we start with the solution

$$u(x, t) = 100 - e^{-(\alpha \frac{n\pi}{L})^2 t} \sin \frac{n\pi}{L} x$$

This solution gives 100 when $x = 0$.

But now we need to check it again for $x = L$, we see it gives $u = 100$ which is not correct. So need to subtract the term $\frac{100}{L}x$ (which is found below for the initial steady state). Now we have the candidate solution

$$u(x, t) = 100 - \frac{100}{L}x + e^{-(\alpha \frac{n\pi}{L})^2 t} \sin \frac{n\pi}{L} x \quad (1)$$

To verify: at $x = 0$, this gives $u = 100$, and at $x = L$, this gives $u(x, t) = 100 - \frac{100}{L}L = 0$, which is what we want.

Since a scaled sum of these solutions is a solution, then the general solution is

$$u(x, t) = 100 - \frac{100}{L}x + \sum_{n=1}^{\infty} b_n e^{-(\alpha \frac{n\pi}{L})^2 t} \sin \frac{n\pi}{L} x \quad (2)$$

Now we need to find the b_n . For this we use the initial conditions, i.e. for $t = 0$.

The sides $x = 0$ is at $u = 0$, and since no time was involved then (this is the initial steady state), the governing PDE is the Laplace equation with only the x spatial coordinate. $\nabla^2 u_0(x) = 0$, a solution to this is $u_0(x) = ax + b$. when $x = 0$, $u_0 = 0$, hence $0 = b$.

When $x = L$, $u = 100$, hence $100 = La + 0$, or $a = \frac{100}{L}$. Hence at $t = 0$

$$u_0 = \frac{100}{L}x$$

So now from equation (2) above, we write

$$\begin{aligned} u(x, 0) = u_0(x) &= \frac{100}{L}x = 100 - \frac{100}{L}x + \sum_{n=1}^{\infty} b_n \sin \frac{n\pi}{L} x \\ \frac{100}{L}x &= 100 - \frac{100}{L}x + \sum_{n=1}^{\infty} b_n \sin \frac{n\pi}{L} x \\ \frac{200}{L}x - 100 &= \sum_{n=1}^{\infty} b_n \sin \frac{n\pi}{L} x \end{aligned}$$

Take the inner product of the LHS and RHS w.r.t. $\sin \frac{n\pi}{L}x$ over $[0, L]$, we get

$$\begin{aligned} \int_0^L \left(\frac{200}{L}x - 100 \right) \sin \frac{n\pi}{L}x \, dx &= \int_0^L \left(\sum_{m=1}^{\infty} b_m \sin \frac{m\pi}{L}x \right) \sin \frac{n\pi}{L}x \, dx \\ 100 \int_0^L \left(\frac{2x}{L} - 1 \right) \sin \frac{n\pi}{L}x \, dx &= \sum_{m=1}^{\infty} b_m \int_0^L \sin \frac{m\pi}{L}x \sin \frac{n\pi}{L}x \, dx \\ 100 \frac{-Ln\pi(1 + \cos(n\pi)) + 2L \sin(n\pi)}{n^2\pi^2} &= b_n \int_0^L \sin^2 \frac{m\pi}{L}x \, dx \\ 100L \frac{-n\pi(1 + \cos(n\pi)) + 2 \sin(n\pi)}{n^2\pi^2} &= b_n \frac{L}{2} \\ b_n &= 200 \left(\frac{-n\pi(1 + \cos(n\pi)) + 2 \sin(n\pi)}{n^2\pi^2} \right) \end{aligned}$$

so looking at few values of $n = 1, 2, 3, 4, \dots$. Hence $b_n = 200 \left(\frac{-n\pi(1 + \cos(n\pi)) + 2 \sin(n\pi)}{n^2\pi^2} \right)$

$$\begin{aligned} b_n &= 200 \left(\frac{-\pi(1 - 1) + 0}{\pi^2} \right), 200 \left(\frac{-2\pi(1 + 1) + 0}{2^2\pi^2} \right), 200 \left(\frac{-3\pi(1 - 1) + 0}{3^2\pi^2} \right), \\ &200 \left(\frac{-4\pi(1 + 1) + 0}{4^2\pi^2} \right), 200 \left(\frac{-5\pi(1 - 1) + 0}{5^2\pi^2} \right) \\ b_n &= 200(0), 200 \left(\frac{-4\pi}{4\pi^2} \right), 200(0), 200 \left(\frac{-8\pi}{16\pi^2} \right), 200(0), \dots, \\ b_n &= 0, -400 \frac{1}{2\pi}, 0, -400 \frac{1}{4\pi}, 0, \\ b_n &= -400 \frac{1}{n\pi} \end{aligned}$$

Hence

$$b_n = -400 \frac{1}{n\pi} \quad n = 2, 4, 6, \dots$$

From equation (2) above we had

$$u(x, t) = 100 - \frac{100}{L}x + \sum_{n=1}^{\infty} b_n e^{-(\alpha \frac{n\pi}{L})^2 t} \sin \frac{n\pi}{L}x$$

Hence

$$u(x, t) = 100 - \frac{100}{L}x + \sum_{n \text{ even}}^{\infty} -400 \frac{1}{n\pi} e^{-(\alpha \frac{n\pi}{L})^2 t} \sin \frac{n\pi}{L}x$$

$$u(x, t) = 100 - \frac{100}{L}x - \frac{400}{\pi} \sum_{n \text{ even}}^{\infty} \frac{1}{n} e^{-(\alpha \frac{n\pi}{L})^2 t} \sin \frac{n\pi}{L}x$$

```
L0 = 2; a = .2;
T0[x_, t_, m_] := 100 - 400/Pi Sum[(-1)^n/(2 n + 1)
Exp[-(a (2 n + 1)/2 Pi/L0)^2 t] Cos[(2 n + 1)/2 Pi/L0 x], {n, 0, m, 1}];
p = Plot3D[T0[x, t, 50], {x, 0, L0}, {t, 0, 10}, PlotRange -> All,
AxesLabel -> {x, "sec", u}, BaseStyle -> 15]
```

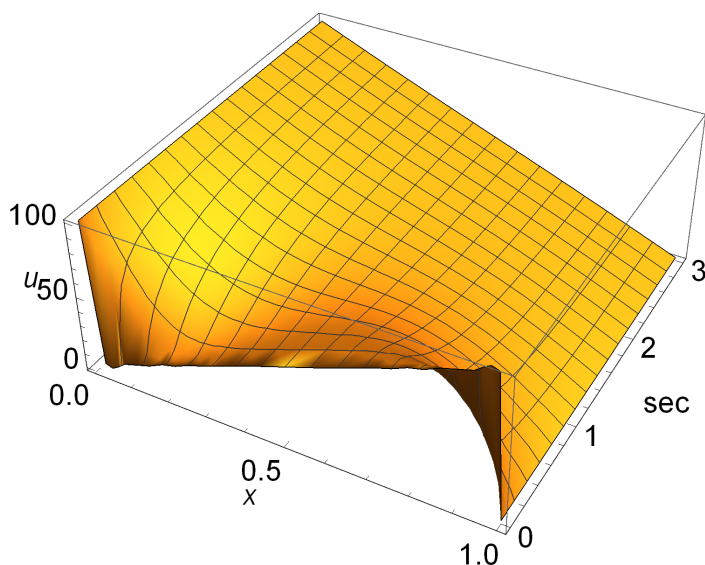

4.8.7 Chapter 13, problem 3.7. Mary Boas book. second edition

A bar of length L with insulated sides has its ends also insulated from time $t = 0$. Initially the temp. is $u = x$, where x is the distance from one end. Determine the temp. distribution inside the bar at time t .

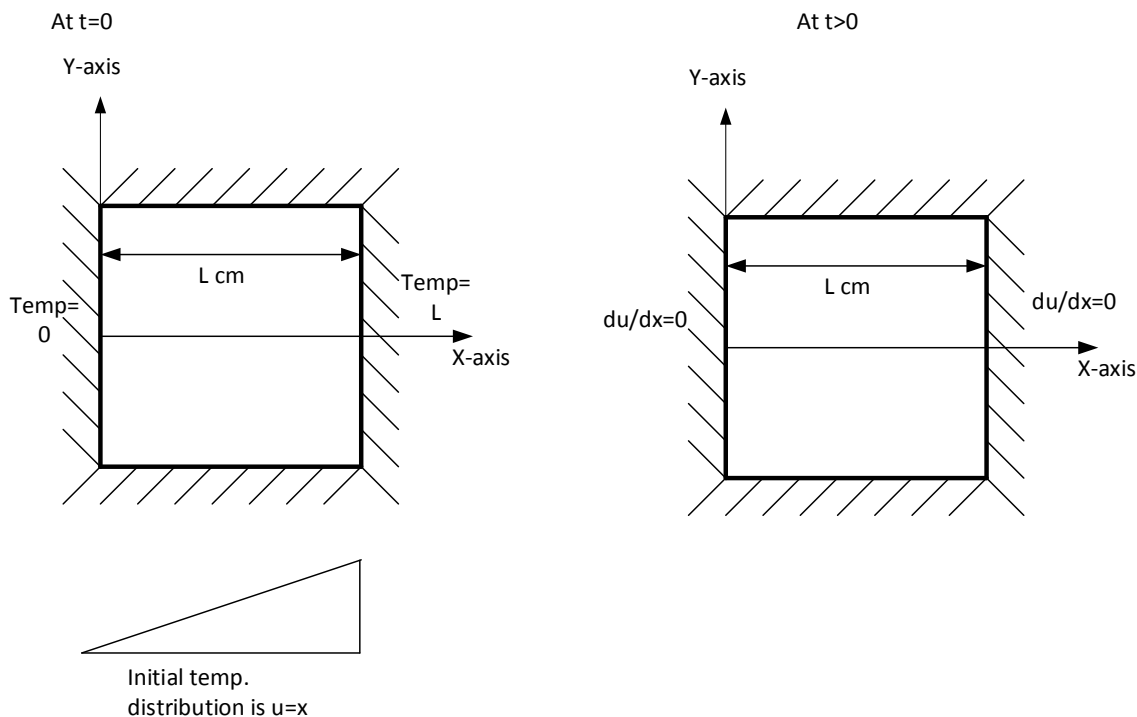

Solution

In this problem, since all 4 sides are insulated, there will be no heat loss. Hence given the initial amount of heat inside the bar, we should obtain a solution that keeps this amount of heat the same. The solution should give a heat distribution at t large, such that it will be equally distributed over the length of the bar.

Since the two end sides are insulated, this is a Neumann type problem, so at $t > 0$ we will use $\frac{\partial u}{\partial x} = 0$ at both ends ($x = 0, x = L$)

This is a heat distribution problem governed by the diffusion or heat equation

$$\nabla^2 u(x, t) = \frac{1}{\alpha^2} \frac{\partial u(x, t)}{\partial t}$$

Similar to problem 3.2, we get the following two candidate solutions to the above PDE

$$u(x, t) = \begin{cases} e^{-\alpha^2 k^2 t} \sin kx \\ e^{-\alpha^2 k^2 t} \cos kx \end{cases}$$

Since these are solutions for $t > 0$ we need to find the conditions that $\frac{\partial u}{\partial x} = 0$ at $x = 0$ and $\frac{\partial u}{\partial x} = 0$ at $x = L$. The above conditions tells us to discard the $\sin kx$ solution because at $x = 0$ $\frac{\partial u}{\partial x} = e^{-\alpha^2 k^2 t} \cos kx = e^{-\alpha^2 k^2 t} \neq 0$. So the second solution we are left with is

$$e^{-\alpha^2 k^2 t} \cos(kx)$$

Which satisfies $\frac{\partial u}{\partial x} = 0$ at $x = 0$. Now at $x = L$, we also want $\frac{\partial u}{\partial x} = 0$, hence $\frac{\partial}{\partial x} e^{-\alpha^2 k^2 t} \cos kx = -k e^{-\alpha^2 k^2 t} \sin kL = 0$. For this to be true we need $k = 0$ or $\sin kL = 0$, i.e. $kL = n\pi$ or $k = \frac{n\pi}{L}$

So there are two solutions to look at, one for $k = 0$ and one for $k = \frac{n\pi}{L}$. Looking at the $k = \frac{n\pi}{L}$ solution first, we start with the solution

$$u(x, t) = e^{-\left(\frac{\alpha n \pi}{L}\right)^2 t} \cos \frac{n\pi}{L} x$$

Now consider the initial conditions at $t = 0$. At $t = 0$, when $x = L/2$, $u = L/2$. Since we are told that $u_0 = x$. So from the above, we get

$$u\left(\frac{L}{2}, 0\right) = \cos \frac{n\pi}{L} \frac{L}{2} = \cos \frac{n\pi}{2}$$

Which is zero for integer n . Hence to force the outcome to be $\frac{L}{2}$, we need to add this term to the solution above. The solution now looks like

$$u(x, t) = \frac{L}{2} + e^{-\left(\frac{\alpha n \pi}{L}\right)^2 t} \cos \frac{n\pi}{L} x \quad (1)$$

Now Since a scaled sum of these solutions is a solution, then the general solution is

$$u(x, t) = \sum_{n=1}^{\infty} b_n \left(e^{-\left(\frac{\alpha n \pi}{L}\right)^2 t} \cos \frac{n\pi}{L} x \right) \quad (2)$$

Now we need to find the b_n . For this we use the initial conditions, i.e. for $t = 0$. We are told that at $t = 0$, $u_0 = x$. From equation (1) above, we write, at time $t = 0$

$$\begin{aligned} u(x, 0) &= x \\ &= \sum_{n=1}^{\infty} b_n \cos \frac{n\pi}{L} x \end{aligned}$$

Taking the inner product of the LHS and RHS w.r.t. $\cos \frac{n\pi}{L} x$ over $[0, L]$ gives

$$\begin{aligned}
\int_0^L x \cos \frac{n\pi}{L} x &= \int_0^L \left(\sum_{m=1}^{\infty} b_m \cos \frac{m\pi}{L} x \right) \cos \frac{n\pi}{L} x dx \\
\int_0^L x \cos \frac{n\pi}{L} x &= \sum_{m=1}^{\infty} b_m \int_0^L \cos \frac{m\pi}{L} x \cos \frac{n\pi}{L} x dx \\
\frac{L^2(-1 + \cos(n\pi)) + n\pi \sin(n\pi)}{n^2\pi^2} &= b_n \int_0^L \cos^2 \frac{m\pi}{L} x dx \\
\frac{L^2(-1 + \cos(n\pi)) + n\pi \sin(n\pi)}{n^2\pi^2} &= b_n \frac{L}{2} \\
b_n &= \frac{2L(-1 + \cos(n\pi)) + n\pi \sin(n\pi)}{n^2\pi^2}
\end{aligned}$$

Looking at few values of $n = 1, 2, 3, 4 \dots$

$$b_n = \frac{2L(-1 + \cos(n\pi)) + n\pi \sin(n\pi)}{n^2\pi^2}$$

Hence

$$\begin{aligned}
b_n &= \frac{2L(-1 + \cos(\pi)) + \pi \sin(\pi)}{\pi^2}, \frac{2L(-1 + \cos(2\pi)) + 2\pi \sin(2\pi)}{2^2\pi^2}, \\
&\frac{2L(-1 + \cos(3\pi)) + 3\pi \sin(3\pi)}{3^2\pi^2}, \frac{2L(-1 + \cos(4\pi)) + 4\pi \sin(4\pi)}{4^2\pi^2}, \dots \\
b_n &= \frac{2L(-1 - 1)}{\pi^2}, \frac{2L(-1 + 1)}{2^2\pi^2}, \frac{2L(-1 - 1)}{3^2\pi^2}, \frac{2L(-1 + 1)}{4^2\pi^2}, \dots \\
b_n &= \frac{2L(-2)}{\pi^2}, \frac{2L(0)}{2^2\pi^2}, \frac{2L(-2)}{3^2\pi^2}, \frac{2L(0)}{4^2\pi^2}, \dots \\
b_n &= \frac{-4L}{\pi^2}, 0, \frac{-4L}{3^2\pi^2}, 0, \dots \\
b_n &= \frac{-4L}{n^2\pi^2}
\end{aligned}$$

Hence

$$b_n = \frac{-4L}{n^2\pi^2} \quad n = 1, 3, 5, \dots$$

From equation (1) above we had

$$\begin{aligned}
 u(x, t) &= \frac{L}{2} + e^{-\left(\frac{\alpha n \pi}{L}\right)^2 t} \cos \frac{n \pi}{L} x \\
 &= \frac{L}{2} + \sum_{\text{odd}}^{\infty} b_n \left(e^{-\left(\frac{\alpha n \pi}{L}\right)^2 t} \cos \frac{n \pi}{L} x \right) \\
 u(x, t) &= \frac{L}{2} + \sum_{\text{odd}}^{\infty} \frac{-4L}{n^2 \pi^2} e^{-\left(\frac{\alpha n \pi}{L}\right)^2 t} \cos \frac{n \pi}{L} x
 \end{aligned}$$

Hence

$$u(x, t) = \frac{L}{2} - \frac{4L}{\pi^2} \sum_{\text{odd}}^{\infty} \frac{1}{n^2} e^{-\left(\frac{\alpha n \pi}{L}\right)^2 t} \cos \frac{n \pi}{L} x$$

```

L0 = 2; a = .2;
T0[x_, t_, m_] := 100 - 400/Pi Sum[(-1)^n/(2 n + 1)
Exp[-(a (2 n + 1)/2 Pi/L0)^2 t] Cos[(2 n + 1)/2 Pi/L0 x], {n, 0, m, 1}];
p = Plot3D[T0[x, t, 50], {x, 0, L0}, {t, 0, 10}, PlotRange -> All,
AxesLabel -> {x, "sec", u}, BaseStyle -> 15]

```

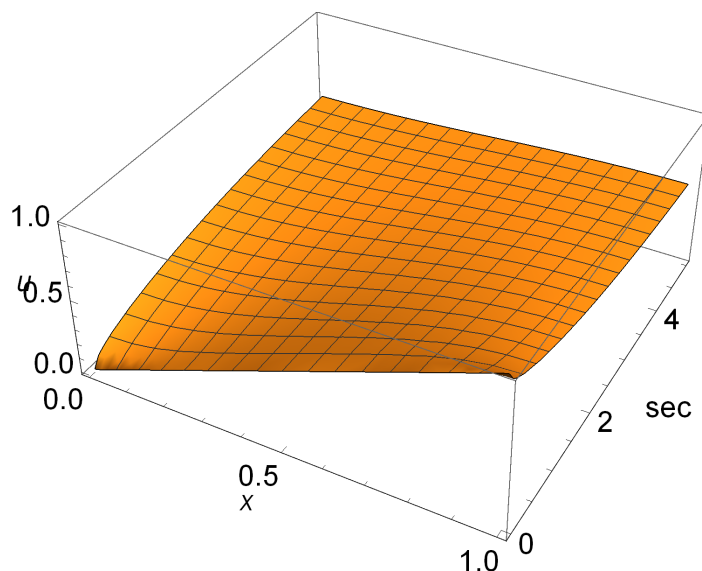

Now we need to consider the $k = 0$ solution we had at the beginning. Starting with $u(x, t) = e^{-\alpha^2 k^2 t} \cos kx$, for $k = 0$, we have $u(x, t) = 1$, and as before we want to look for a general solution as $u_g(x, t) = \sum_{n=1}^{\infty} b_n u(x, t)$, which is now will be

$$u_g(x, t) = \sum_{n=1}^{\infty} b_n$$

To find b_n , as before we use the conditions at $t = 0$, which is $u(x, 0) = x$. Therefore

$$u(x, 0) = x = \sum_{n=1}^{\infty} b_n$$

Therefore $\sum_{n=1}^{\infty} b_n = x$. The general solution in this case is given by

$$u_g(x, t) = \sum_{n=1}^{\infty} b_n$$

$$u_g(x, t) = x$$

which is what we are required to show. What this means is that for $k = 0$, the heat distribution does not change. So this is the same as the time-independent initial conditions.

4.8.8 Chapter 13, problem 3.9. Mary Boas book. second edition

A bar of length $L = 2$ with insulated side at $x = 0$ only, at $t = 0$ held at zero temperature. at $t > 0$ the right side is held at $T = 100$ degrees. Determine the time dependent temperature distribution inside the bar

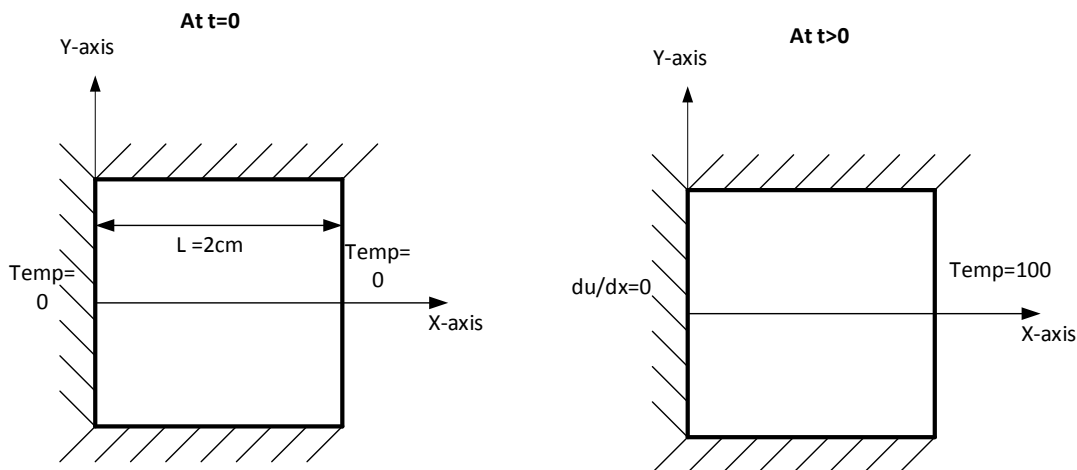

Solution

In this problem, since left side is insulated, this is a Neumann condition at the $x = 0$ side. So at $t > 0$ we will use $\frac{\partial u}{\partial x} = 0$ at $x = 0$. This is a heat distribution problem governed by the diffusion or heat equation

$$\nabla^2 u(x, t) = \frac{1}{\alpha^2} \frac{\partial u(x, t)}{\partial t}$$

Similar to problem 3.2, we get the following 2 candidate solutions to the above PDE

$$u(x, t) = \begin{cases} e^{-\alpha^2 k^2 t} \sin kx \\ e^{-\alpha^2 k^2 t} \cos kx \end{cases}$$

Since these are solutions for $t > 0$. We need to find the conditions that $\frac{\partial u}{\partial x} = 0$ at $x = 0$ and $u = 100$ at $x = L$. Since we want $\frac{\partial u}{\partial x} = 0$ at $x = 0$, then we can not use the $\sin kx$ solution. We are left with the solution $e^{-\alpha^2 k^2 t} \cos(kx)$ which satisfies $\frac{\partial u}{\partial x} = 0$ at $x = 0$. Now at $x = L$, we want $u = 100$, hence $e^{-\alpha^2 k^2 t} \cos(kL) = 100$. The way this is presented will not allow exact expression for k so we have to write $u(L, t) = 100 + e^{-\alpha^2 k^2 t} \cos(kL)$, and now we are able to set only the $e^{-\alpha^2 k^2 t} \cos(kL)$ term to zero, which means we need to have $\cos(kL) = 0$ or $kL = \frac{2n-1}{2}\pi$ or $k = \frac{2n-1}{2} \frac{\pi}{L}$. Hence we start with the solution

$$\begin{aligned} u(x, t) &= 100 + e^{-\alpha^2 \left(\frac{2n-1}{2} \frac{\pi}{L}\right)^2 t} \cos\left(\frac{2n-1}{2} \frac{\pi}{L} x\right) \\ &= 100 + e^{-\left(\alpha \frac{2n-1}{2} \frac{\pi}{L}\right)^2 t} \cos\left(\frac{2n-1}{2} \frac{\pi x}{L}\right) \end{aligned} \quad (1)$$

Since a scaled sum of these solutions is a solution, then the general solution is

$$u(x, t) = 100 + \sum_{n=1}^{\infty} b_n e^{-\left(\alpha \frac{2n-1}{2} \frac{\pi}{L}\right)^2 t} \cos\left(\frac{2n-1}{2} \frac{\pi x}{L}\right) \quad (2)$$

Now we need to find the b_n . For this we use the initial conditions. We are told that at $t = 0$, $u_0 = 0$. So now from equation (1) above

$$\begin{aligned} u(x, 0) &= 0 \\ &= 100 + \sum_{n=1}^{\infty} b_n \cos\left(\frac{2n-1}{2} \frac{\pi x}{L}\right) \\ -100 &= \sum_{n=1}^{\infty} b_n \cos\left(\frac{2n-1}{2} \frac{\pi x}{L}\right) \end{aligned}$$

Taking the inner product of the LHS and RHS w.r.t. $\cos\left(\frac{2n-1}{2} \frac{\pi x}{L}\right)$ over $[0, L]$ gives

$$\begin{aligned}
-100 \int_0^L \cos\left(\frac{2n-1}{2} \frac{\pi x}{L}\right) dx &= \int_0^L \left(\sum_{m=1}^{\infty} b_m \cos\left(\frac{2m-1}{2} \frac{\pi x}{L}\right) \right) \cos\left(\frac{2n-1}{2} \frac{\pi x}{L}\right) \\
-100 \left[\frac{1}{\frac{2n-1}{2} \frac{\pi}{L}} \sin\left(\frac{2n-1}{2} \frac{\pi x}{L}\right) \right]_0^L &= \sum_{m=1}^{\infty} b_m \int_0^L \cos\left(\frac{2m-1}{2} \frac{\pi x}{L}\right) \cos\left(\frac{2n-1}{2} \frac{\pi x}{L}\right) dx \\
-100 \frac{2L}{(2n-1)\pi} \left[\sin\left(\frac{2n-1}{2} \frac{\pi x}{L}\right) \right]_0^L &= b_n \int_0^L \cos^2\left(\frac{2n-1}{2} \frac{\pi x}{L}\right) dx \\
\frac{-200L}{(2n-1)\pi} \left[\sin\left(\frac{2n-1}{2} \frac{\pi L}{L}\right) - \sin(0) \right] &= b_n \frac{L}{2} \\
\frac{-200L}{(2n-1)\pi} \left[\sin\left(\frac{2n-1}{2} \pi\right) \right] &= b_n \frac{L}{2} \\
b_n &= \frac{-400}{(2n-1)\pi} \left[\sin\left(\frac{2n-1}{2} \pi\right) \right]
\end{aligned}$$

Looking at few values of n , $b_n = \frac{-400}{(2n-1)\pi} \left[\sin\left(\frac{2n-1}{2} \pi\right) \right]$, hence

$$\begin{aligned}
b_n &= \frac{-400}{(2-1)\pi} \left[\sin\left(\frac{2-1}{2} \pi\right) \right], \frac{-400}{(4-1)\pi} \left[\sin\left(\frac{4-1}{2} \pi\right) \right], \\
&\frac{-400}{(6-1)\pi} \left[\sin\left(\frac{6-1}{2} \pi\right) \right], \frac{-400}{(8-1)\pi} \left[\sin\left(\frac{8-1}{2} \pi\right) \right], \dots \\
b_n &= \frac{-400}{\pi} \left[\sin\left(\frac{1}{2} \pi\right) \right], \frac{-400}{3\pi} \left[\sin\left(\frac{3}{2} \pi\right) \right], \frac{-400}{5\pi} \left[\sin\left(\frac{5}{2} \pi\right) \right], \dots \\
b_n &= \frac{-400}{\pi}, \frac{+400}{3\pi}, \frac{-400}{5\pi}, \dots \\
b_n &= -\frac{(-1)^n}{2n+1} \frac{400}{\pi} \quad n = 0, 1, 2, 3, \dots
\end{aligned}$$

Therefore

$$b_n = -\frac{(-1)^n}{2n+1} \frac{400}{\pi} \quad n = 0, 1, 2, 3, \dots$$

From equation (2) above we had

$$u(x, t) = 100 + \sum_{n=1}^{\infty} b_n e^{-\left(\alpha \frac{2n-1}{2} \frac{\pi}{L}\right)^2 t} \cos\left(\frac{2n-1}{2} \frac{\pi x}{L}\right)$$

Substituting the value for b_n and adjusting the summation index to start from $n = 0$ since this is where b_n is defined to start from, and so we need to replace $\frac{2n-1}{2}$ by $\frac{2n+1}{2}$ in the rest of the above terms. Hence

$$\begin{aligned}
 u(x, t) &= 100 + \sum_{n=0}^{\infty} -\frac{(-1)^n 400}{2n+1} \frac{1}{\pi} e^{-\left(\alpha \frac{2n+1}{2} \frac{\pi}{L}\right)^2 t} \cos\left(\frac{2n+1}{2} \frac{\pi x}{L}\right) \\
 &= 100 - \frac{400}{\pi} \sum_{n=0}^{\infty} \frac{(-1)^n}{2n+1} e^{-\left(\alpha \frac{2n+1}{2} \frac{\pi}{L}\right)^2 t} \cos\left(\frac{2n+1}{2} \frac{\pi x}{L}\right)
 \end{aligned}$$

```

L0 = 2; a = .2;
T0[x_, t_, m_] := 100 - 400/Pi Sum[(-1)^n/(2 n + 1)
Exp[-(a (2 n + 1)/2 Pi/L0)^2 t] Cos[(2 n + 1)/2 Pi/L0 x], {n, 0, m, 1}];
p = Plot3D[T0[x, t, 50], {x, 0, L0}, {t, 0, 10}, PlotRange -> All,
AxesLabel -> {x, "sec", u}, BaseStyle -> 15]

```

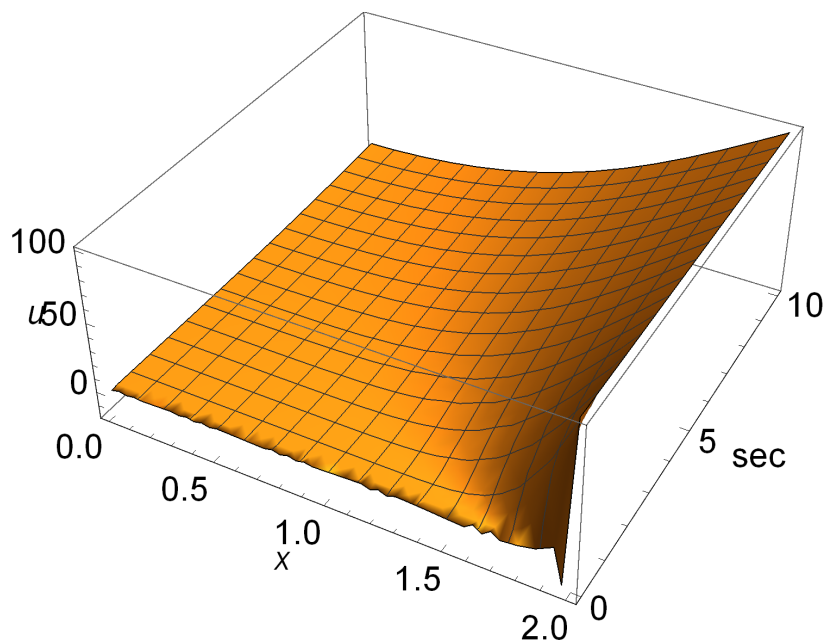

4.8.9 Problem chapter 13, 3.10. Mary Boas book. Second edition

Separate the wave equation $\nabla^2 u = \frac{1}{v} \frac{\partial^2 u}{\partial t^2}$ into space and time equation and show that the space equation is the Helmholtz equation.

Solution

Assume that the solution is of this form $u(x, y, z, t) = F(x, y, z)T(t)$

That is, the solution of the PDE is the product of 2 functions, one that depends only on the spatial displacements and a function that depends only on time.

Substituting back in the PDE which when written in the long form is:

$$\frac{\partial^2 u}{\partial x^2} + \frac{\partial^2 u}{\partial y^2} + \frac{\partial^2 u}{\partial z^2} = \frac{1}{v} \frac{\partial^2 u}{\partial t^2}$$

Hence,

$$\begin{aligned} \frac{\partial u}{\partial x} &= T(t) \frac{\partial F}{\partial x} \\ \frac{\partial^2 u}{\partial x^2} &= T(t) \frac{\partial^2 F}{\partial x^2} \end{aligned}$$

similarly we get

$$\begin{aligned} \frac{\partial^2 u}{\partial y^2} &= T(t) \frac{\partial^2 F}{\partial y^2} \\ \frac{\partial^2 u}{\partial z^2} &= T(t) \frac{\partial^2 F}{\partial z^2} \\ \frac{\partial^2 u}{\partial t^2} &= F(x, y, z) \frac{d^2 T}{dt^2} \end{aligned}$$

Now $\nabla^2 u = \frac{1}{v} \frac{\partial^2 u}{\partial t^2}$ can be written as

$$\begin{aligned} T(t) \frac{\partial^2 F}{\partial x^2} + T(t) \frac{\partial^2 F}{\partial y^2} + T(t) \frac{\partial^2 F}{\partial z^2} &= \frac{1}{v} F(x, y, z) \frac{d^2 T}{dt^2} \\ T \nabla^2 F &= \frac{1}{v} F \frac{d^2 T}{dt^2} \end{aligned}$$

dividing the equation by $T F$, we get

$$\frac{1}{F} \nabla^2 F = \frac{1}{v} \frac{1}{T} \frac{d^2 T}{dt^2}$$

Since the LHS is a function of space only, and RHS is a function of time only, and they equal to each others, then they must be equal to a constant, say $-k^2$

Hence we get

$$\begin{aligned} \frac{1}{F} \nabla^2 F &= -k^2 \\ \frac{1}{v} \frac{1}{T} \frac{d^2 T}{dt^2} &= -k^2 \end{aligned}$$

Looking at the space equation only:

$$\begin{aligned}\frac{1}{F(x, y, z)} \nabla^2 F(x, y, z) &= -k^2 \\ \nabla^2 F(x, y, z) &= -F(x, y, z) k^2 \\ \nabla^2 F(x, y, z) + F(x, y, z) k^2 &= 0\end{aligned}$$

So the space equation is the Helmholtz equation.

4.9 HW 9

Local contents

4.9.1	Chapter 13, problem 6.1 Mary Boas. Second edition	229
4.9.2	chapter 13, problem 4.1. Mary Boas, second edition	234
4.9.3	chapter 13, problem 4.2. Mary Boas, second edition	236
4.9.4	chapter 13, problem 4.6. Mary Boas, second edition	239
4.9.5	chapter 13, problem 5.1. Mary Boas, second edition	243
4.9.6	chapter 13, problem 5.2. Mary Boas, second edition	245
4.9.7	chapter 13, problem 5.4. Mary Boass, second edition	248
4.9.8	chapter 13, problem 5.11. Mary Boas, second edition	256

4.9.1 Chapter 13, problem 6.1 Mary Boas. Second edition

chapter 13

6.1

will use

$$z = J_n(k_{mn}) \cos n\theta \quad \text{to} \quad k_{mn} \approx \sqrt{t}$$

Complete Figure 6.1.

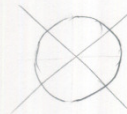
 k_{mn} is the m^{th} zero of J_n .Circle is divided into as many sectors as $2n$. for example, when $n=1$, we will setwhen $n=2$, we will set

this is because we want a solution

$$\cos 2\theta = \pm \frac{\pi}{2}$$

$$\text{which means } \theta = \pm \frac{\pi}{2n}$$

$$\text{so for } n=1, \theta = +\frac{\pi}{2}, -\frac{\pi}{2}$$

$$n=2, 2\theta = \pm \frac{\pi}{2} \quad \text{or } \theta = \pm \frac{\pi}{4}$$

$$\text{for } n=3, 3\theta = \pm \frac{\pi}{2} \quad \text{or } \theta = \pm \frac{\pi}{6}$$

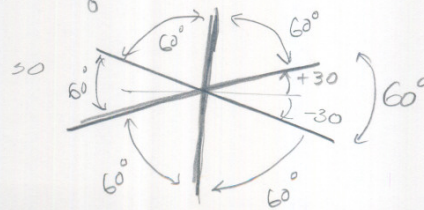
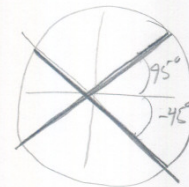

etc..

now, for changing of the m .

$$\text{from } z = J_n(K_{mn}r) \cos n\theta \cos K_{mn}vt$$

we want $J_n(K_{mn}r)$ to be zero.

as m increases, $K_{m_2} > K_{m_1}$ when $m_2 > m_1$

so r becomes smaller for each m increasing.

if original radius of drum is 1, then

$$r \text{ for } m=1 \Rightarrow 1$$

$$r \text{ for } m=2 \Rightarrow \frac{K_{10}}{K_{20}} < 1$$

$$r \text{ for } m=3 \Rightarrow \frac{K_{10}}{K_{30}} < \frac{K_{10}}{K_{20}}$$

So each time m increases by 1 we add a smaller radius inside. so now I show

the complete figure for $n=0,1,2$, $m=1,2,3$.

→

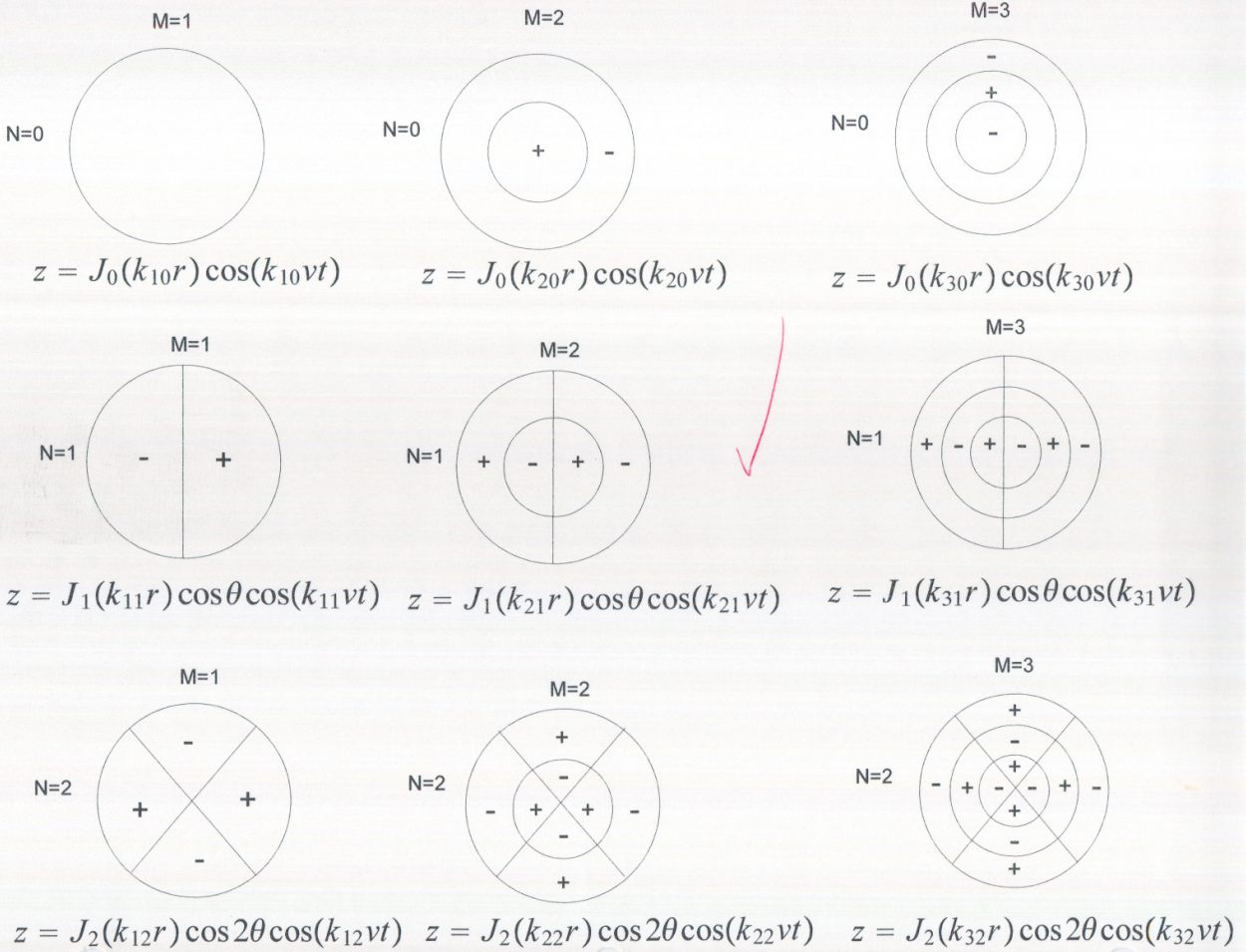

chapter 13, 6.2

look up first 3 zeros of K_{mn} of each Bessel function J_0, J_1, J_2, J_3 . find the first 6 frequencies of a vibrating circular membrane as multiples of fundamental frequency.

Solution

frequency is given by $\omega_{mn} = K_{mn} v$

Fundamental frequency is $\omega_{10} v$.
 First zero of J_0

so ratio of frequency ω_{mn} to Fundamental is

$$\frac{\omega_{mn}}{\omega_{10}} = \frac{K_{mn}}{K_{10}}$$

First zero of J_0 .

so
$$\omega_{mn} = \omega_{10} \frac{K_{mn}}{K_{10}}$$

Using this I can find frequencies as multiple of Fundamental freq.

→

First 3 Zeros of Bessel functions. using Handbook.

J_0

		<u>zero</u>
$m=1$	\rightarrow	2.4
$m=2$	\rightarrow	5.65
$m=3$	\rightarrow	8.55

J_1

$m=1$	\rightarrow	3.75
$m=2$	\rightarrow	7.25
$m=3$	\rightarrow	10.05

J_2

$m=1$	\rightarrow	5.05
$m=2$	\rightarrow	8.45
$m=3$	\rightarrow	11.55

J_3

$m=1$	\rightarrow	6.3
$m=2$	\rightarrow	13.1
$m=3$	\rightarrow	16.3

So now I can find the first 6 frequencies.

First = ω_{10} This is Fundamental Frequency.

$$\text{Second} = \omega_{11} = \omega_{10} \frac{K_{11}}{K_{10}} = \omega_{10} \frac{3.75}{2.4} = \boxed{1.56 \omega_0}$$

$$\text{Third} = \omega_{12} = \omega_{10} \frac{K_{12}}{K_{10}} = \omega_{10} \frac{5.05}{2.4} = \boxed{2.1 \omega_0}$$

$$\text{Fourth} = \omega_{20} = \omega_{10} \frac{K_{20}}{K_{10}} = \omega_{10} \frac{5.65}{2.4} = \boxed{2.35 \omega_0}$$

$$\text{Fifth} = \omega_{21} = \omega_{10} \frac{K_{21}}{K_{10}} = \omega_{10} \frac{7.25}{2.4} = \boxed{3.01 \omega_0}$$

$$\text{Sixth} = \omega_{22} = \omega_{10} \frac{K_{22}}{K_{10}} = \omega_{10} \frac{8.45}{2.4} = \boxed{3.5 \omega_0}$$

4.9.2 chapter 13, problem 4.1. Mary Boas, second edition

Complete the plucked string problem to get equation 4.0

Solution

Here we start with the solution given in 4.8

$$y_0 = \sum_{n=1}^{\infty} b_n \sin\left(\frac{n\pi x}{L}\right) = f(x) \quad (1)$$

Where $f(x)$ represents the initial position (shape) of the string.

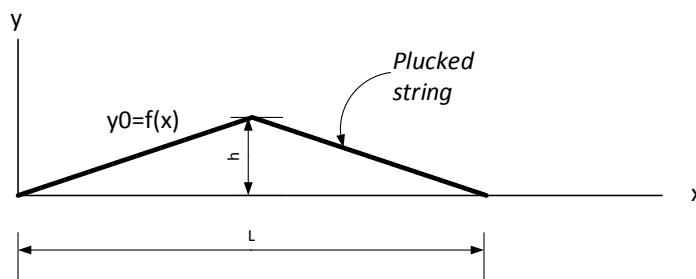

Now need to find b_n

First need to define $f(x)$, from diagram we see that from $x = 0$ to $x = L/2$ the slope is $\frac{h}{L/2} = \frac{2h}{L}$ hence from equation of line we get $y = \frac{2h}{L}x$

From $x = L/2$ to $x = L$, slope is $-\frac{2h}{L}$, so $y = h - \frac{2h}{L}\left(x - \frac{L}{2}\right) = h - \frac{2h}{L}x + h = 2h - \frac{2h}{L}x = 2\left(h - \frac{hx}{L}\right)$

so we have

$$f(x) = \begin{cases} \frac{2h}{L}x & 0 \leq x \leq \frac{L}{2} \\ 2\left(h - \frac{hx}{L}\right) & \frac{L}{2} < x \leq L \end{cases}$$

so from (1) we get, after applying inner product w.r.t. $\sin\left(\frac{n\pi x}{L}\right)$

$$\begin{aligned}
b_n \int_0^L \sin^2\left(\frac{n\pi x}{L}\right) &= \int_0^L f(x) \sin\left(\frac{n\pi x}{L}\right) dx \\
b_n \frac{L}{2} &= \int_0^{\frac{L}{2}} f(x) \sin\left(\frac{n\pi x}{L}\right) dx + \int_{\frac{L}{2}}^L f(x) \sin\left(\frac{n\pi x}{L}\right) dx \\
b_n \frac{L}{2} &= \int_0^{\frac{L}{2}} \frac{2h}{L} x \sin\left(\frac{n\pi x}{L}\right) dx + \int_{\frac{L}{2}}^L 2\left(h - \frac{hx}{L}\right) \sin\left(\frac{n\pi x}{L}\right) dx \\
b_n \frac{L}{2} &= \frac{2h}{L} \int_0^{\frac{L}{2}} x \sin\left(\frac{n\pi x}{L}\right) dx + \int_{\frac{L}{2}}^L 2h \sin\left(\frac{n\pi x}{L}\right) dx - \int_{\frac{L}{2}}^L \frac{2hx}{L} \sin\left(\frac{n\pi x}{L}\right) dx \\
b_n \frac{L}{2} &= \frac{2h}{L} \int_0^{\frac{L}{2}} x \sin\left(\frac{n\pi x}{L}\right) dx + 2h \int_{\frac{L}{2}}^L \sin\left(\frac{n\pi x}{L}\right) dx - \frac{2h}{L} \int_{\frac{L}{2}}^L x \sin\left(\frac{n\pi x}{L}\right) dx \\
b_n \frac{L}{2} &= \frac{16 h L \cos\left(\frac{n\pi}{4}\right) \sin\left(\frac{n\pi}{4}\right)^3}{n^2 \pi^2} \\
b_n &= \frac{32 h \cos\left(\frac{n\pi}{4}\right) \sin\left(\frac{n\pi}{4}\right)^3}{n^2 \pi^2}
\end{aligned}$$

so

$$b_n = \frac{32 h L \cos\left(\frac{n\pi}{4}\right) \sin\left(\frac{n\pi}{4}\right)^3}{n^2 \pi^2}$$

Looking at few values of n to see the pattern

$$\begin{aligned}
b_n &= \frac{32 h \cos\left(\frac{\pi}{4}\right) \sin\left(\frac{\pi}{4}\right)^3}{1^2 \pi^2}, \frac{32 h \cos\left(\frac{2\pi}{4}\right) \sin\left(\frac{2\pi}{4}\right)^3}{2^2 \pi^2}, \frac{32 h \cos\left(\frac{3\pi}{4}\right) \sin\left(\frac{3\pi}{4}\right)^3}{3^2 \pi^2}, \dots \\
&= \frac{8h}{\pi^2}, 0, -\frac{8h}{9\pi^2}, 0, \frac{8h}{25\pi^2}, \dots \\
&= \frac{8h}{\pi^2} \left(1, 0, -\frac{1}{9}, 0, \frac{1}{25}, \dots\right)
\end{aligned}$$

Notice that we have terms for only odd n .

Now, substituting the above in the general solution given in equation 4.7 in book, which is

$$y = \sum_{n=1}^{\infty} b_n \sin\left(\frac{n\pi x}{L}\right) \cos\left(\frac{n\pi vt}{L}\right)$$

Gives

$$y = \frac{8h}{\pi^2} \left(\sin\left(\frac{\pi x}{L}\right) \cos\left(\frac{\pi vt}{L}\right) + 0 + -\frac{1}{9} \sin\left(\frac{3\pi x}{L}\right) \cos\left(\frac{3\pi vt}{L}\right) + 0 + \frac{1}{25} \sin\left(\frac{5\pi x}{L}\right) \cos\left(\frac{5\pi vt}{L}\right) + \dots \right)$$

$$y = \frac{8h}{\pi^2} \left(\sin\left(\frac{\pi x}{L}\right) \cos\left(\frac{\pi vt}{L}\right) - \frac{1}{9} \sin\left(\frac{3\pi x}{L}\right) \cos\left(\frac{3\pi vt}{L}\right) + \frac{1}{25} \sin\left(\frac{5\pi x}{L}\right) \cos\left(\frac{5\pi vt}{L}\right) + \dots \right)$$

The above is the result we are asked to show.

4.9.3 chapter 13, problem 4.2. Mary Boas, second edition

A string of length L has zero initial velocity and a displacement $y_0(x)$ as shown. Find the displacement as a function of x and t .

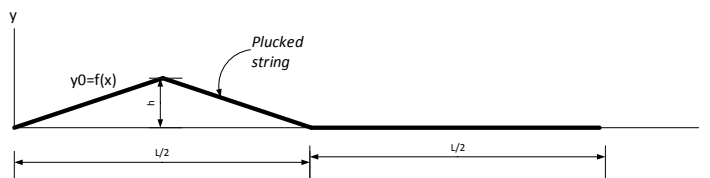

Solution

The PDE that governs this problem is the wave equation $\nabla^2 y = \frac{1}{v^2} \frac{\partial^2 y}{\partial t^2}$

The candidate solutions are

$$y = \begin{cases} \sin(kx) \sin(\omega t) \\ \sin(kx) \cos(\omega t) \\ \cos(kx) \sin(\omega t) \\ \cos(kx) \cos(\omega t) \end{cases}$$

where $\omega = kv$ and $k = \frac{2\pi}{\lambda}$ where λ is the wave length

Now we discard solutions that contains $\cos kx$ since the string is fixed at $x = 0$.

So we are left with

$$y = \begin{cases} \sin(kx) \sin(\omega t) \\ \sin(kx) \cos(\omega t) \end{cases}$$

Now, $y = 0$ at $x = L$ then from $\sin kx = 0$ or $\sin kL = 0$ we need $k = \frac{n\pi}{L}$

Hence solutions become

$$y = \begin{cases} \sin\left(\frac{n\pi}{L}x\right) \sin\left(\frac{n\pi}{L}vt\right) \\ \sin\left(\frac{n\pi}{L}x\right) \cos\left(\frac{n\pi}{L}vt\right) \end{cases}$$

Applying initial conditions, which says that at time $t = 0$, velocity is zero.

Hence from above, after taking $\frac{\partial y}{\partial t}$, we get

$$\frac{\partial y}{\partial t} = \begin{cases} \frac{n\pi v}{L} \sin\left(\frac{n\pi}{L}x\right) \cos\left(\frac{n\pi v}{L}t\right) \\ -\frac{n\pi v}{L} \sin\left(\frac{n\pi}{L}x\right) \sin\left(\frac{n\pi v}{L}t\right) \end{cases}$$

For the above to be zero at $t = 0$ then we discard first solution above with $\cos t$ in it. Hence final general solution is now

$$y = \left\{ \sin\left(\frac{n\pi}{L}x\right) \cos\left(\frac{n\pi}{L}vt\right) \right.$$

A general solution is a linear combination of the above solutions, hence

$$y = \sum_{n=1}^{\infty} b_n \sin\left(\frac{n\pi}{L}x\right) \cos\left(\frac{n\pi}{L}vt\right) \quad (1)$$

To find b_n , we apply the second initial condition, which is $y = y_0 = f(x)$

(Notice that we use two initial conditions, i.e. at time $t=0$ we are looking at speed and position, this is because we started with a PDE with $\frac{\partial^2 y}{\partial t^2}$ in it, which is a second order in t .)

At $t=0$, (1) becomes

$$y = \sum_{n=1}^{\infty} b_n \sin\left(\frac{n\pi}{L}x\right) = f(x) \quad (2)$$

To find $f(x)$ from diagram, we see that for $0 \leq x \leq \frac{L}{4}$, $y = x \frac{h}{L/4} = \frac{4h}{L}x$

For $\frac{L}{4} < x \leq \frac{L}{2}$, $y = -\left(x - \frac{L}{4}\right) \frac{h}{L/4} + h = -\left(x - \frac{L}{4}\right) \frac{4h}{L} + h = -x \frac{4h}{L} + \frac{L}{4} \frac{4h}{L} + h = -x \frac{4h}{L} + 2h$

For $\frac{L}{2} < x \leq L$, $y = 0$

Hence

$$y = \begin{cases} \frac{4h}{L}x & 0 \leq x \leq \frac{L}{4} \\ 2h - x \frac{4h}{L} & \frac{L}{4} < x \leq \frac{L}{2} \\ 0 & \frac{L}{2} < x \leq L \end{cases}$$

Do the inner product on both sides of equation (2) w.r.t. $\sin \frac{n\pi}{L}x$

$$\begin{aligned} b_n \int_0^L \sin^2 \frac{n\pi}{L}x \, dx &= \int_0^L f(x) \sin \frac{n\pi}{L}x \, dx \\ b_n \frac{L}{2} &= \int_0^{\frac{L}{4}} f(x) \sin \frac{n\pi}{L}x \, dx + \int_{\frac{L}{4}}^{\frac{L}{2}} f(x) \sin \frac{n\pi}{L}x \, dx + \int_{\frac{L}{2}}^L f(x) \sin \frac{n\pi}{L}x \, dx \\ &= \int_0^{\frac{L}{4}} \frac{4h}{L}x \sin \frac{n\pi}{L}x \, dx + \int_{\frac{L}{4}}^{\frac{L}{2}} \left(2h - x \frac{4h}{L}\right) \sin \frac{n\pi}{L}x \, dx + \int_{\frac{L}{2}}^L 0 \sin \frac{n\pi}{L}x \, dx \\ &= \int_0^{\frac{L}{4}} \frac{4h}{L}x \sin \frac{n\pi}{L}x \, dx + \int_{\frac{L}{4}}^{\frac{L}{2}} 2h \sin\left(\frac{n\pi}{L}x\right) - x \frac{4h}{L} \sin\left(\frac{n\pi}{L}x\right) \, dx \\ &= \int_0^{\frac{L}{4}} \frac{4h}{L}x \sin \frac{n\pi}{L}x \, dx + \int_{\frac{L}{4}}^{\frac{L}{2}} 2h \sin\left(\frac{n\pi}{L}x\right) dx - \int_{\frac{L}{4}}^{\frac{L}{2}} x \frac{4h}{L} \sin\left(\frac{n\pi}{L}x\right) \, dx \\ &= \frac{4h}{L} \int_0^{\frac{L}{4}} x \sin \frac{n\pi}{L}x \, dx + 2h \int_{\frac{L}{4}}^{\frac{L}{2}} \sin\left(\frac{n\pi}{L}x\right) dx - \frac{4h}{L} \int_{\frac{L}{4}}^{\frac{L}{2}} x \sin\left(\frac{n\pi}{L}x\right) \, dx \\ b_n &= \frac{8h}{n^2\pi^2} \left(2 \sin\left(\frac{n\pi}{4}\right) - \sin \frac{n\pi}{2}\right) \end{aligned}$$

Looking at few values of b_n

$$\begin{aligned}
b_n &= \frac{8h}{1^2\pi^2} \left(2 \sin\left(\frac{\pi}{4}\right) - \sin\frac{\pi}{2} \right), \frac{8h}{2^2\pi^2} \left(2 \sin\left(\frac{2\pi}{4}\right) - \sin\frac{2\pi}{2} \right), \frac{8h}{3^2\pi^2} \left(2 \sin\left(\frac{3\pi}{4}\right) - \sin\frac{3\pi}{2} \right), \dots \\
&= \frac{8h}{\pi^2} \left[\left(2 \sin\left(\frac{\pi}{4}\right) - \sin\frac{\pi}{2} \right), \frac{1}{2^2} \left(2 \sin\frac{2\pi}{4} - \sin\frac{2\pi}{2} \right), \frac{1}{3^2} \left(2 \sin\frac{3\pi}{4} - \sin\frac{3\pi}{2} \right), \dots \right] \\
&= \frac{8h}{\pi^2} \left[\frac{1}{n^2} \left\{ \left(2 \sin\left(\frac{\pi}{4}\right) - \sin\frac{\pi}{2} \right), \left(2 \sin\frac{2\pi}{4} - \sin\frac{2\pi}{2} \right), \left(2 \sin\frac{3\pi}{4} - \sin\frac{3\pi}{2} \right), \dots \right\} \right] \\
&= \frac{8h}{\pi^2} \left[\frac{1}{n^2} \left(2 \sin\left(\frac{n\pi}{4}\right) - \sin\frac{n\pi}{2} \right) \right]
\end{aligned}$$

Hence from equation (1) above, we get

$$\begin{aligned}
y &= \sum_{n=1}^{\infty} b_n \sin \frac{n\pi}{L} x \cos \frac{n\pi}{L} vt \\
&= \sum_{n=1}^{\infty} \frac{8h}{\pi^2} \left[\frac{1}{n^2} \left(2 \sin\left(\frac{n\pi}{4}\right) - \sin\frac{n\pi}{2} \right) \right] \sin \frac{n\pi}{L} x \cos \frac{n\pi}{L} vt \\
&= \frac{8h}{\pi^2} \sum_{n=1}^{\infty} B_n \sin \frac{n\pi}{L} x \cos \frac{n\pi}{L} vt
\end{aligned}$$

Where

$$B_n = \frac{1}{n^2} \left(2 \sin\left(\frac{n\pi}{4}\right) - \sin\frac{n\pi}{2} \right)$$

The above is the result required to show.

4.9.4 chapter 13, problem 4.6. Mary Boas, second edition

A string of length L is initially stretched straight, its ends are fixed for all time t . At time $t=0$ its points are given the velocity $V(x) = \left(\frac{\partial y}{\partial t}\right)_{t=0}$ as shown in diagram below. Determine the shape of the string at time t .



Solution

The PDE that governs this problem is the wave equation $\nabla^2 y = \frac{1}{v^2} \frac{\partial^2 y}{\partial t^2}$

The candidate solutions are

$$y = \begin{cases} \sin(kx) \sin(\omega t) \\ \sin(kx) \cos(\omega t) \\ \cos(kx) \sin(\omega t) \\ \cos(kx) \cos(\omega t) \end{cases}$$

Where $\omega = kv$ and $k = \frac{2\pi}{\lambda}$ where λ is the wave length

Now we discard solutions that contains $\cos kx$ since the string is fixed at $x = 0$.

So we are left with

$$y = \begin{cases} \sin(kx) \sin(\omega t) \\ \sin(kx) \cos(\omega t) \end{cases}$$

Now, $y = 0$ at $x = L$ then from $\sin kx = 0$ or $\sin kL = 0$ we need $k = \frac{n\pi}{L}$

Hence solutions become

$$y = \begin{cases} \sin \frac{n\pi}{L}x \sin \frac{n\pi}{L}vt \\ \sin \frac{n\pi}{L}x \cos \frac{n\pi}{L}vt \end{cases}$$

Applying initial conditions, which says that at time $t = 0$, velocity is given by $V(x)$

Hence from above, after taking $\frac{\partial y}{\partial t}$, we get

$$\frac{\partial y}{\partial t} = \begin{cases} \frac{n\pi v}{L} \sin \frac{n\pi}{L}x \cos \frac{n\pi v}{L}t \\ -\frac{n\pi v}{L} \sin \frac{n\pi}{L}x \sin \frac{n\pi v}{L}t \end{cases}$$

For the above we discard velocity solution above with $\sin t$ in it since that will give zero velocity at time $t=0$, which is not the case here. Hence we discard y solution with $\cos t$ in it, then the final general solution for y is now

$$y = \sin \frac{n\pi}{L}x \sin \frac{n\pi}{L}vt$$

A general solution is a linear combination of the above solutions, hence

$$y = \sum_{n=1}^{\infty} b_n \sin \frac{n\pi x}{L} \sin \frac{n\pi vt}{L} \quad (1)$$

To find b_n , we apply the velocity initial condition. Hence differentiate equation (1) and set $t=0$, we have

$$\frac{\partial y}{\partial t} = \sum_{n=1}^{\infty} b_n \frac{n\pi v}{L} \sin \frac{n\pi x}{L} \cos \frac{n\pi vt}{L}$$

Setting $t=0$

$$\frac{\partial y}{\partial t} = \sum_{n=1}^{\infty} b_n \frac{n\pi v}{L} \sin \frac{n\pi x}{L} = V_{t=0} \quad (2)$$

Now to find $V_{t=0}$. From diagram, we see that for $0 \leq x \leq \frac{L}{2} - w$, $V_{t=0} = 0$

For $\frac{L}{2} - w < x \leq \frac{L}{2} + w$, $V_{t=0} = h$

For $\frac{L}{2} + w < x \leq L$, $V_{t=0} = 0$

Hence

$$V_{t=0} = \begin{cases} 0 & 0 \leq x \leq \frac{L}{2} - w \\ h & \frac{L}{2} - w < x \leq \frac{L}{2} + w \\ 0 & \frac{L}{2} + w < x \leq L \end{cases}$$

Do the inner product on both sides of equation (2) w.r.t. $\sin \frac{n\pi}{L}x$

$$\begin{aligned}
b_n \frac{n\pi v}{L} \int_0^L \sin^2 \frac{n\pi}{L} x \, dx &= \int_0^L V(x) \sin \frac{n\pi x}{L} \, dx \\
b_n \frac{n\pi v}{2} &= \int_0^{\frac{L}{2}-w} 0 \sin \frac{n\pi}{L} x \, dx + \int_{\frac{L}{2}-w}^{\frac{L}{2}+w} h \sin \frac{n\pi x}{L} \, dx + \int_{\frac{L}{2}+w}^L 0 \sin \frac{n\pi}{L} x \, dx \\
b_n \frac{n\pi v}{2} &= \int_{\frac{L}{2}-w}^{\frac{L}{2}+w} h \sin \frac{n\pi x}{L} \, dx \\
b_n \frac{n\pi v}{2} &= -h \frac{L}{n\pi} \left[\cos \frac{n\pi x}{L} \right]_{\frac{L}{2}-w}^{\frac{L}{2}+w} \\
b_n \frac{n\pi v}{2} &= -h \frac{L}{n\pi} \left[\cos \frac{n\pi \left(\frac{L}{2} + w \right)}{L} - \cos \frac{n\pi \left(\frac{L}{2} - w \right)}{L} \right] \\
b_n \frac{n\pi v}{2} &= -h \frac{L}{n\pi} \left[\cos \left(\frac{n\pi}{2} + \frac{n\pi w}{L} \right) - \cos \left(\frac{n\pi}{2} - \frac{n\pi w}{L} \right) \right] \\
b_n &= -\frac{2hL}{n^2 \pi^2 v} \left[\cos \left(\frac{n\pi}{2} + \frac{n\pi w}{L} \right) - \cos \left(\frac{n\pi}{2} - \frac{n\pi w}{L} \right) \right]
\end{aligned}$$

But $\cos(a + b) = \cos(a) \cos(b) - \sin(a) \sin(b)$

and $\cos(a - b) = \cos(a) \cos(b) + \sin(a) \sin(b)$

Let $a = \frac{n\pi}{2}$, $b = \frac{n\pi w}{L}$

Hence b_n becomes

$$\begin{aligned}
b_n &= -\frac{2hL}{n^2 \pi^2 v} [\cos(a + b) - \cos(a - b)] \\
&= -\frac{2hL}{n^2 \pi^2 v} [\cos(a) \cos(b) - \sin(a) \sin(b) - \{\cos(a) \cos(b) + \sin(a) \sin(b)\}] \\
&= -\frac{2hL}{n^2 \pi^2 v} [\cos(a) \cos(b) - \sin(a) \sin(b) - \cos(a) \cos(b) - \sin(a) \sin(b)] \\
&= -\frac{2hL}{n^2 \pi^2 v} [-\sin(a) \sin(b) - \sin(a) \sin(b)] \\
&= \frac{4hL}{n^2 \pi^2 v} \sin(a) \sin(b) \\
&= \frac{4hL}{n^2 \pi^2 v} \sin \left(\frac{n\pi}{2} \right) \sin \left(\frac{n\pi w}{L} \right)
\end{aligned}$$

For even n , the term $\sin \left(\frac{n\pi}{2} \right)$ is zero. For n odd $\sin \left(\frac{n\pi}{2} \right) = 1$ when $n = 1, 5, 9, \dots$ and $\sin \left(\frac{n\pi}{2} \right) = -1$ when $n = 3, 7, 11, \dots$ Hence

$$b_n = A(n) \frac{4hL}{n^2 \pi^2 v} \sin\left(\frac{n\pi w}{L}\right) \quad n = 1, 3, 5, 7, \dots$$

And $A(n)$ is a function which returns 1 when $n = 1, 5, 9, \dots$ and returns -1 when $n = 3, 7, 11, \dots$

Hence now we have b_n we can substitute in (1)

$$\begin{aligned} y &= \sum_{n=1}^{\infty} b_n \sin \frac{n\pi x}{L} \sin \frac{n\pi vt}{L} \\ y &= \sum_{n \text{ odd}}^{\infty} A(n) \frac{4hL}{n^2 \pi^2 v} \sin\left(\frac{n\pi w}{L}\right) \left[\sin \frac{n\pi x}{L} \sin \frac{n\pi vt}{L} \right] \\ y &= \frac{4hL}{\pi^2 v} \sum_{n \text{ odd}}^{\infty} A(n) \frac{1}{n^2} \sin\left(\frac{n\pi w}{L}\right) \left[\sin \frac{n\pi x}{L} \sin \frac{n\pi vt}{L} \right] \end{aligned}$$

Which is the general solution. Looking at few expanded terms in the series we get

$$y = \frac{4hL}{\pi^2 v} \left\{ \sin\left(\frac{\pi w}{L}\right) \sin \frac{\pi x}{L} \sin \frac{\pi vt}{L} - \frac{1}{9} \sin\left(\frac{3\pi w}{L}\right) \sin \frac{3\pi x}{L} \sin \frac{3\pi vt}{L} + \frac{1}{25} \sin\left(\frac{5\pi w}{L}\right) \sin \frac{5\pi x}{L} \sin \frac{5\pi vt}{L} \right\}$$

Which is the result required.

4.9.5 chapter 13, problem 5.1. Mary Boas, second edition

Compute numerically the coefficients $c_m = \frac{200}{k_m J_1(k_m)}$ for the first 3 terms of the series $u = \sum_{m=1}^{\infty} c_m J_0(k_m r) e^{-k_m z}$ for the steady state temp. in a solid semi-infinite cylinder when $u = 0$ at $r = 1$ and $u = 100$ at $z = 0$. find u at $r = 1/2, z = 1$

Solution

Here, we are looking at the solution for temp. inside a semi-infinite cylinder. This solution is for the case of a uniform temp. distribution on the boundary $z = 0$ is given by u equation shown above. Note that in the expression $c_m = \frac{200}{k_m J_1(k_m)}$, the k_m are the zeros of J_0 not J_1 .

Need to find c_1, c_2, c_3 where $c_1 = \frac{200}{k_1 J_1(k_1)}$

To find k_1 and $J_1(k_1)$ I used mathematica.

I plotted $J_0(x)$ to see where the zeros are located first

```
In[16]:= Plot[BesselJ[0, x], {x, 0, 10}]
```

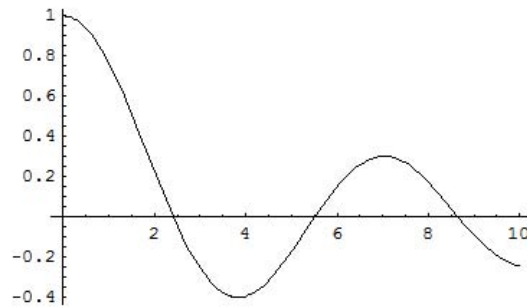

```
Out[16]= - Graphics -
```

So I see there is a zero near 2,5, and 9. I use mathematica to find these:

```
In[20]:= k1 = FindRoot[BesselJ[0, x] == 0, {x, 2}]
```

```
Out[20]= {x -> 2.40483 }
```

```
In[21]:= k2 = FindRoot[BesselJ[0, x] == 0, {x, 5}]
```

```
Out[21]= {x -> 5.52008 }
```

```
In[22]:= k3 = FindRoot[BesselJ[0, x] == 0, {x, 9}]
```

```
Out[22]= {x -> 8.65373 }
```

Now I need to find $J_1(k_m)$. This is the result for 3 terms:

```
In[37]:= BesselJ[1, k1[[1, 2]]]
```

```
Out[37]= 0.519147
```

```
In[38]:= BesselJ[1, k2[[1, 2]]]
```

```
Out[38]= -0.340265
```

```
In[39]:= BesselJ[1, k3[[1, 2]]]
```

```
Out[39]= 0.271452
```

Hence, now the c_m terms can be found:

$$c_1 = \frac{200}{k_1 J_1(k_1)} = \frac{200}{(2.404)(0.519)} = 160.30$$

$$c_2 = \frac{200}{k_2 J_1(k_2)} = \frac{200}{(5.52)(-0.34)} = -106.56$$

$$c_3 = \frac{200}{k_3 J_1(k_3)} = \frac{200}{(8.65)(0.27)} = 85.635$$

Evaluating $u = \sum_{m=1}^{\infty} c_m J_0(k_m r) e^{-k_m z}$ for the first 3 terms when $r = 1/2, z = 1$

$$\begin{aligned} u &= c_1 J_0(k_1 r) e^{-k_1 z} + c_2 J_0(k_2 r) e^{-k_2 z} + c_3 J_0(k_3 r) e^{-k_3 z} \\ &= c_1 J_0\left(k_1 \frac{1}{2}\right) e^{-k_1} + c_2 J_0\left(k_2 \frac{1}{2}\right) e^{-k_2} + c_3 J_0\left(k_3 \frac{1}{2}\right) e^{-k_3} \\ &= (160.30) J_0\left(2.404 \frac{1}{2}\right) e^{-2.404} - (106.56) J_0\left(5.52 \frac{1}{2}\right) e^{-5.52} + (85.635) J_0\left(8.65 \frac{1}{2}\right) e^{-8.65} \\ &= (160.30) J_0(1.202) e^{-2.404} - (106.56) J_0(2.76) e^{-5.52} + (85.635) J_0(4.325) e^{-8.65} \end{aligned}$$

Mathematica was used to evaluate J_0 values above.

```
In[40]:= BesselJ[0, 1.202]
```

```
Out[40]:= 0.670136
```

```
In[41]:= BesselJ[0, 2.76]
```

```
Out[41]:= -0.168385
```

```
In[42]:= BesselJ[0, 4.325]
```

```
Out[42]:= -0.356614
```

Hence

$$\begin{aligned} u &= (160.30)(0.67) e^{-2.404} - (106.56)(-0.168) e^{-5.52} + (85.635)(-0.356) e^{-8.65} \\ u &= 9.7043 + 7.1713 \times 10^{-2} - 5.3389 \times 10^{-3} \\ u &= 9.7707 \text{ degrees} \end{aligned}$$

4.9.6 chapter 13, problem 5.2. Mary Boas, second edition

Find the solution for the steady state temp. distribution in a solid semi-infinite cylinder if the boundary temp. are $u = 0$ at $r = 1$ and $u = y = r \sin \theta$ at $z = 0$.

Solution

The candidate solutions are given by the solution to the Laplace equation in cylindrical coordinates which are

$$u = \begin{cases} J_n(k r) \sin(n\theta) e^{-k z} & (1) \\ J_n(k r) \cos(n\theta) e^{-k z} & (2) \end{cases}$$

Where k is a zero of J_n (This is because we have used the B.C. of $u = 0$ at $r = 1$ to determine that the k 's have to be the zeros of J_n) when deriving the above solutions. See book page 560.

From boundary conditions we want $u = r \sin \theta$ when $z = 0$, hence we need to keep the solution (1) above, with $n = 1$. Hence a solution is

$$u = J_1(k r) \sin(\theta) e^{-k z} \quad (3)$$

A general solution is a linear series combinations (eigenfunctions) of (3), each eigenfunction for each of the zeros of J_1 . Call these zeros k_m

$$u = \sum_{m=1}^{\infty} c_m J_1(k_m r) \sin(\theta) e^{-k_m z} \quad (4)$$

We now apply B.C. at $z = 0$ to find c_m . From (4) when $z = 0$

$$r \sin \theta = \sum_{m=1}^{\infty} c_m J_1(k_m r) \sin(\theta) \quad (5)$$

We use (5) to find c_m and then substitute into (4) to obtain the final solution.

To find c_m from (5), take the inner product of each side with respect to $r J_1(k_u r)$ from $r = 0$ to $r = 1$

$$\begin{aligned} \int_0^1 r \sin \theta [r J_1(k_u r)] dr &= \sum_{m=1}^{\infty} c_m \left(\int_0^1 J_1(k_m r) \sin(\theta) [r J_1(k_u r)] dr \right) \\ \sin \theta \int_0^1 r^2 J_1(k_u r) dr &= \sum_{m=1}^{\infty} c_m \sin(\theta) \left(\int_0^1 J_1(k_m r) [r J_1(k_u r)] dr \right) \end{aligned}$$

Dividing each side by $\sin \theta$

$$\int_0^1 r^2 J_1(k_u r) dr = \sum_{m=1}^{\infty} c_m \left(\int_0^1 J_1(k_m r) [r J_1(k_u r)] dr \right)$$

From orthogonality of Bessel function, we know that

$$\int_0^1 J_p(k_m r) r J_p(k_u r) dr = 0$$

If $m \neq u$. Hence in above equation all terms on the right drop except for one when $u = m$. We get

$$\int_0^1 r^2 J_1(k_m r) dr = c_m \int_0^1 r J_1(k_m r) J_1(k_m r) dr$$

Or

$$c_m = \frac{\int_0^1 r^2 J_1(k_m r) dr}{\int_0^1 r J_1(k_m r) J_1(k_m r) dr} \quad (6)$$

The integral in the denominator above is found from equation 19.10 in text on page 523 which gives

$$\int_0^1 r J_1(k_m r) J_1(k_m r) dr = \frac{1}{2} [J_2(k_m)]^2 \quad (7)$$

Now, we need to find the integral of the numerator in equation (6).

Using equation 15.1 in text, page 514, which says

$$\frac{d}{dx} [x^p J_p(x)] = x^p J_{p-1}(x)$$

Putting $p = 2$ above, and letting $x = k_m r$ gives

$$\begin{aligned} \frac{1}{k_m} \frac{d}{dr} [(k_m r)^2 J_2(k_m r)] &= (k_m r)^2 J_1(k_m r) \\ \frac{1}{k_m} \frac{d}{dr} [k_m^2 r^2 J_2(k_m r)] &= k_m^2 r^2 J_1(k_m r) \\ \frac{1}{k_m} \frac{d}{dr} [r^2 J_2(k_m r)] &= r^2 J_1(k_m r) \end{aligned}$$

Integrating each side w.r.t r from 0 ... 1

$$\begin{aligned} \frac{1}{k_m} \int_0^1 \frac{d}{dr} [r^2 J_2(k_m r)] dr &= \int_0^1 r^2 J_1(k_m r) dr \\ \frac{1}{k_m} [r^2 J_2(k_m r)]_0^1 &= \int_0^1 r^2 J_1(k_m r) dr \\ \frac{1}{k_m} [J_2(k_m) - 0] &= \int_0^1 r^2 J_1(k_m r) dr \\ \frac{1}{k_m} J_2(k_m) &= \int_0^1 r^2 J_1(k_m r) dr \quad (8) \end{aligned}$$

Substituting (7) and (8) into (6)

$$\begin{aligned} c_m &= \frac{\int_0^1 r^2 J_1(k_m r) dr}{\int_0^1 r J_1(k_m r) J_1(k_m r) dr} \\ &= \frac{\frac{1}{k_m} J_2(k_m)}{\frac{1}{2} [J_2(k_m)]^2} \\ &= \frac{2}{k_m J_2(k_m)} \end{aligned}$$

Substituting this into (4) above, we get

$$\begin{aligned} u &= \sum_{m=1}^{\infty} c_m J_1(k_m r) \sin(\theta) e^{-k_m z} \\ u &= \sum_{m=1}^{\infty} \frac{2}{k_m J_2(k_m)} J_1(k_m r) \sin(\theta) e^{-k_m z} \end{aligned}$$

where k_m are zeros of J_1

The above is the result we are asked to show.

4.9.7 chapter 13, problem 5.4. Mary Boass, second edition

A flat circular plate of radius 1 is initially at temp. 100^0 . From $t = 0$ on, the circumference of the plate is held at 0^0 . Find the time-dependent temp distribution $u(r, \theta, t)$

Solution

First convert heat equation from Cartesian coordinates to polar.

heat equation in 2D Cartesian is

$$\nabla^2 u = \frac{\partial^2}{\partial x^2} u + \frac{\partial^2}{\partial y^2} u = \frac{1}{\alpha^2} \frac{\partial}{\partial t} u$$

First need to express Laplacian operator ∇^2 in polar coordinates:

$$\begin{aligned} x &= r \cos \theta \\ y &= r \sin \theta \end{aligned}$$

Hence

$$\frac{\partial x}{\partial r} = \cos \theta \quad (\text{A})$$

$$\frac{\partial y}{\partial r} = \sin \theta$$

And

$$\frac{\partial x}{\partial \theta} = -r \sin \theta \quad (\text{B})$$

$$\frac{\partial y}{\partial \theta} = r \cos \theta$$

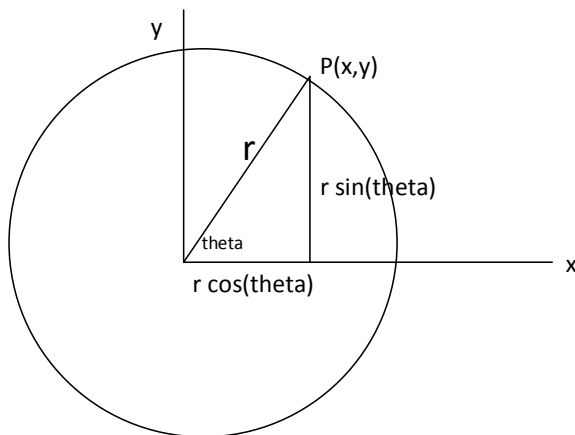

From geometry, we also know that

$$r = \sqrt{x^2 + y^2}$$

$$\theta = \arctan \frac{y}{x}$$

The above 2 relations imply

$$\frac{\partial}{\partial r} = \frac{\partial x}{\partial r} \frac{\partial}{\partial x} + \frac{\partial y}{\partial r} \frac{\partial}{\partial y} \quad \text{and} \quad \frac{\partial}{\partial \theta} = \frac{\partial x}{\partial \theta} \frac{\partial}{\partial x} + \frac{\partial y}{\partial \theta} \frac{\partial}{\partial y}$$

Hence we can express the above, using equations (A) and (B) as follows:

$$\begin{aligned} \frac{\partial}{\partial r} &= \frac{\partial x}{\partial r} \frac{\partial}{\partial x} + \frac{\partial y}{\partial r} \frac{\partial}{\partial y} \\ &= \cos \theta \frac{\partial}{\partial x} + \sin \theta \frac{\partial}{\partial y} \end{aligned}$$

Multiply each side by r

$$\begin{aligned} r \frac{\partial}{\partial r} &= r \cos \theta \frac{\partial}{\partial x} + r \sin \theta \frac{\partial}{\partial y} \\ &= x \frac{\partial}{\partial x} + y \frac{\partial}{\partial y} \end{aligned} \quad (1)$$

Squaring each sides of (1) gives

$$\begin{aligned} r \frac{\partial}{\partial r} \left(r \frac{\partial}{\partial r} \right) &= \left(x \frac{\partial}{\partial x} + y \frac{\partial}{\partial y} \right)^2 \\ r \left(r \frac{\partial^2}{\partial r^2} + \frac{\partial}{\partial r} \right) &= x \frac{\partial}{\partial x} x \frac{\partial}{\partial x} + y \frac{\partial}{\partial y} y \frac{\partial}{\partial y} + 2x \frac{\partial}{\partial x} y \frac{\partial}{\partial y} \\ r^2 \frac{\partial^2}{\partial r^2} + r \frac{\partial}{\partial r} &= x \frac{\partial}{\partial x} \left(x \frac{\partial}{\partial x} \right) + y \frac{\partial}{\partial y} \left(y \frac{\partial}{\partial y} \right) + 2x \frac{\partial}{\partial x} \left(y \frac{\partial}{\partial y} \right) \\ &= x \left(x \frac{\partial^2}{\partial x^2} + \overset{=1}{\frac{\partial}{\partial x}} x \frac{\partial}{\partial x} \right) + y \left(y \frac{\partial^2}{\partial y^2} + \overset{=1}{\frac{\partial}{\partial y}} y \frac{\partial}{\partial y} \right) + 2x \left(y \frac{\partial^2}{\partial x \partial y} + \overset{=0}{\frac{\partial}{\partial x}} y \frac{\partial}{\partial y} \right) \\ &= x^2 \frac{\partial^2}{\partial x^2} + x \frac{\partial}{\partial x} + y^2 \frac{\partial^2}{\partial y^2} + y \frac{\partial}{\partial y} + 2xy \frac{\partial^2}{\partial x \partial y} \end{aligned} \quad (2)$$

Notice that when manipulating of differential operators, $x \frac{\partial}{\partial x} \neq \frac{\partial}{\partial x} x$. Similarly

$$\begin{aligned} \frac{\partial}{\partial \theta} &= \frac{\partial x}{\partial \theta} \frac{\partial}{\partial x} + \frac{\partial y}{\partial \theta} \frac{\partial}{\partial y} \\ &= -r \sin \theta \frac{\partial}{\partial x} + r \cos \theta \frac{\partial}{\partial y} \\ &= -y \frac{\partial}{\partial x} + x \frac{\partial}{\partial y} \end{aligned} \quad (3)$$

Squaring each side of (3) gives

$$\begin{aligned}
\left(\frac{\partial}{\partial\theta}\right)^2 &= \left(-y\frac{\partial}{\partial x} + x\frac{\partial}{\partial y}\right)^2 \\
\frac{\partial}{\partial\theta}\frac{\partial}{\partial\theta} &= -y\frac{\partial}{\partial x}\left(-y\frac{\partial}{\partial x}\right) + x\frac{\partial}{\partial y}\left(x\frac{\partial}{\partial y}\right) - y\frac{\partial}{\partial x}\left(x\frac{\partial}{\partial y}\right) + x\frac{\partial}{\partial y}\left(-y\frac{\partial}{\partial x}\right) \\
\frac{\partial^2}{\partial\theta^2} &= -y\left(-y\frac{\partial^2}{\partial x^2} + \overbrace{\frac{\partial}{\partial x}(-y)}^{=0}\frac{\partial}{\partial x}\right) + x\left(x\frac{\partial^2}{\partial y^2} + \overbrace{\frac{\partial}{\partial y}(x)}^{=0}\frac{\partial}{\partial y}\right) \\
&\quad - y\left(x\frac{\partial^2}{\partial y\partial x} + \overbrace{\frac{\partial}{\partial x}x}^{=1}\frac{\partial}{\partial y}\right) + x\left(-y\frac{\partial^2}{\partial x\partial y} + \overbrace{\frac{\partial}{\partial y}y}^{=1}\frac{\partial}{\partial x}\right) \\
&= y^2\frac{\partial^2}{\partial x^2} + x^2\frac{\partial^2}{\partial y^2} - yx\frac{\partial^2}{\partial y\partial x} - y\frac{\partial}{\partial y} - xy\frac{\partial^2}{\partial x\partial y} - x\frac{\partial}{\partial x} \\
&= y^2\frac{\partial^2}{\partial x^2} + x^2\frac{\partial^2}{\partial y^2} - 2yx\frac{\partial^2}{\partial y\partial x} - y\frac{\partial}{\partial y} - x\frac{\partial}{\partial x} \tag{4}
\end{aligned}$$

Adding equation (2) and (4) and carry cancellations

$$\begin{aligned}
r^2\frac{\partial^2}{\partial r^2} + r\frac{\partial}{\partial r} + \frac{\partial^2}{\partial\theta^2} &= \left(x^2\frac{\partial^2}{\partial x^2} + x\frac{\partial}{\partial x} + y^2\frac{\partial^2}{\partial y^2} + y\frac{\partial}{\partial y} + 2xy\frac{\partial^2}{\partial x\partial y}\right) + \left(y^2\frac{\partial^2}{\partial x^2} + x^2\frac{\partial^2}{\partial y^2} - 2yx\frac{\partial^2}{\partial y\partial x} - y\frac{\partial}{\partial y} - x\frac{\partial}{\partial x}\right) \\
r^2\frac{\partial^2}{\partial r^2} + r\frac{\partial}{\partial r} + \frac{\partial^2}{\partial\theta^2} &= \left(x^2\frac{\partial^2}{\partial x^2} + y^2\frac{\partial^2}{\partial y^2}\right) + \left(y^2\frac{\partial^2}{\partial x^2} + x^2\frac{\partial^2}{\partial y^2}\right)
\end{aligned}$$

Hence we get

$$\begin{aligned}
r^2\frac{\partial^2}{\partial r^2} + r\frac{\partial}{\partial r} + \frac{\partial^2}{\partial\theta^2} &= x^2\frac{\partial^2}{\partial x^2} + y^2\frac{\partial^2}{\partial y^2} + y^2\frac{\partial^2}{\partial x^2} + x^2\frac{\partial^2}{\partial y^2} \\
&= (x^2 + y^2)\left(\frac{\partial^2}{\partial x^2} + \frac{\partial^2}{\partial y^2}\right)
\end{aligned}$$

Dividing by r^2

$$\frac{\partial^2}{\partial r^2} + \frac{1}{r}\frac{\partial}{\partial r} + \frac{1}{r^2}\frac{\partial^2}{\partial\theta^2} = \frac{(x^2 + y^2)}{r^2}\left(\frac{\partial^2}{\partial x^2} + \frac{\partial^2}{\partial y^2}\right)$$

But $r^2 = x^2 + y^2$ hence

$$\frac{\partial^2}{\partial r^2} + \frac{1}{r}\frac{\partial}{\partial r} + \frac{1}{r^2}\frac{\partial^2}{\partial\theta^2} = \left(\frac{\partial^2}{\partial x^2} + \frac{\partial^2}{\partial y^2}\right) = \nabla^2$$

Now that we have the Laplacian in polar coordinates, we can solve the problem by applying separation of variables on the heat PDE expressed in polar coordinates.

$$\frac{\partial^2}{\partial r^2}u + \frac{1}{r}\frac{\partial}{\partial r}u + \frac{1}{r^2}\frac{\partial^2}{\partial \theta^2}u = \frac{1}{\alpha^2}\frac{\partial}{\partial t}u \quad (5)$$

Let solution $u(r, \theta, t)$ be a linear combination of functions each depends on only r, θ , or t

$$u(r, \theta, t) = R(r)\Theta(\theta)T(t) \quad (6)$$

Substitute (6) in (5). First evaluate the various derivatives:

$$\frac{\partial}{\partial r}u = \Theta(\theta)T(t)\frac{\partial}{\partial r}R(r)$$

$$\frac{\partial^2}{\partial r^2}u = \Theta(\theta)T(t)\frac{\partial^2}{\partial r^2}R(r)$$

$$\frac{\partial}{\partial \theta}u = R(r)T(t)\frac{\partial}{\partial \theta}\Theta(\theta)$$

$$\frac{\partial^2}{\partial \theta^2}u = R(r)T(t)\frac{\partial^2}{\partial \theta^2}\Theta(\theta)$$

$$\frac{\partial}{\partial t}u = R(r)\Theta(\theta)\frac{\partial}{\partial t}T(t)$$

Hence equation (5) becomes

$$\Theta(\theta)T(t)\frac{d^2}{dr^2}R(r) + \frac{1}{r}\Theta(\theta)T(t)\frac{d}{dr}R(r) + \frac{1}{r^2}R(r)T(t)\frac{d^2}{d\theta^2}\Theta(\theta) = \frac{1}{\alpha^2}R(r)\Theta(\theta)\frac{d}{dt}T(t)$$

Divide by $R(r)\Theta(\theta)T(t)$

$$\begin{aligned} \frac{1}{R(r)}\frac{d^2}{dr^2}R(r) + \frac{1}{r}\frac{1}{R(r)}\frac{d}{dr}R(r) + \frac{1}{r^2}\frac{1}{\Theta(\theta)}\frac{d^2}{d\theta^2}\Theta(\theta) &= \frac{1}{\alpha^2}\frac{1}{T(t)}\frac{d}{dt}T(t) \\ \frac{1}{R(r)}\left[\frac{d^2}{dr^2}R(r) + \frac{1}{r}\frac{d}{dr}R(r)\right] + \frac{1}{r^2}\frac{1}{\Theta(\theta)}\frac{d^2}{d\theta^2}\Theta(\theta) &= \frac{1}{\alpha^2}\frac{1}{T(t)}\frac{d}{dt}T(t) \end{aligned}$$

We notice that the RHS depends only on t and the LHS depends only on r, θ and they equal to each others, hence they both must be constant. Let this constant be $-k^2$

Hence

$$\frac{1}{\alpha^2} \frac{1}{T(t)} \frac{d}{dt} T(t) = -k^2 \quad (7)$$

$$\frac{1}{R(r)} \left[\frac{d^2}{dr^2} R(r) + \frac{1}{r} \frac{d}{dr} R(r) \right] + \frac{1}{r^2} \frac{1}{\Theta(\theta)} \frac{d^2}{d\theta^2} \Theta(\theta) = -k^2 \quad (8)$$

equation (7) is a linear first order ODE with constant coeff. $\frac{d}{dt} T(t) = -\alpha^2 T(t) k^2$ or $\frac{dT(t)}{T(t)} = -\alpha^2 k^2 dt$

Integrating to solve gives

$$\int \frac{dT(t)}{T(t)} = \int -\alpha^2 k^2 dt$$

$$\ln T(t) = -\alpha^2 k^2 t$$

or

$$T(t) = e^{-\alpha^2 k^2 t} \quad (9)$$

Looking at equation (8). Multiply each sides by r^2 we get

$$\frac{r^2}{R(r)} \left[\frac{d^2}{dr^2} R(r) + \frac{1}{r} \frac{d}{dr} R(r) \right] + \frac{1}{\Theta(\theta)} \frac{d^2}{d\theta^2} \Theta(\theta) = -r^2 k^2$$

$$\frac{r^2}{R(r)} \left[\frac{d^2}{dr^2} R(r) + \frac{1}{r} \frac{d}{dr} R(r) \right] + r^2 k + \frac{1}{\Theta(\theta)} \frac{d^2}{d\theta^2} \Theta(\theta) = 0$$

$$r^2 \left(\frac{1}{R(r)} \left[\frac{d^2}{dr^2} R(r) + \frac{1}{r} \frac{d}{dr} R(r) \right] + k^2 \right) + \frac{1}{\Theta(\theta)} \frac{d^2}{d\theta^2} \Theta(\theta) = 0 \quad (10)$$

The second term depends only on θ and the first term depends only on r and they are equal, hence they must be both constant. Let this constant be $-n^2$ hence

$$\frac{1}{\Theta(\theta)} \frac{d^2}{d\theta^2} \Theta(\theta) = -n^2$$

$$\frac{d^2}{d\theta^2} \Theta(\theta) = -n^2 \Theta(\theta)$$

This is a second order linear ODE with constant coeff. Solution is

$$\Theta(\theta) = \begin{cases} \sin n\theta \\ \cos n\theta \end{cases} \quad (11)$$

From (10) we now have

$$\begin{aligned} r^2 \left(\frac{1}{R(r)} \left[\frac{d^2}{dr^2} R(r) + \frac{1}{r} \frac{d}{dr} R(r) \right] + k^2 \right) - n^2 &= 0 \\ \frac{r^2}{R(r)} \left[\frac{d^2}{dr^2} R(r) + \frac{1}{r} \frac{d}{dr} R(r) \right] + r^2 k^2 - n^2 &= 0 \\ r^2 \left[\frac{d^2}{dr^2} R(r) + \frac{1}{r} \frac{d}{dr} R(r) \right] + (r^2 k^2 - n^2) R(r) &= 0 \\ r^2 \frac{d^2}{dr^2} R(r) + r \frac{d}{dr} R(r) + (r^2 k^2 - n^2) R(r) &= 0 \end{aligned} \quad (12)$$

Equation (12) is the Bessel D.E., its solutions are $J_n(kr)$ and $N_n(kr)$. As described on book on page 560, we can not use the $N_n(kr)$ solution since plate contains the origin and $N_n(0)$ is not defined. So we use solution $R(r) = J_n(kr)$. From boundary conditions, we want solution to be zero at $r = 1$, hence we want $J_n(k) = 0$, hence the k 's are the zeros of J_n

Putting these solutions together, we get from (6)

$$\begin{aligned} u(r, \theta, t) &= R(r)\Theta(\theta)T(t) \\ &= \begin{cases} J_n(kr) \sin n\theta e^{-\alpha^2 k^2 t} \\ J_n(kr) \cos n\theta e^{-\alpha^2 k^2 t} \end{cases} \end{aligned}$$

From symmetry of plate, the solution can not depend on the angle θ , hence let $n = 0$ and so as not to get $u = 0$, we must pick the solution with $\cos n\theta$ term. Hence our solution now is

$$u(r, t) = J_0(kr) e^{-\alpha^2 k^2 t}$$

Where k is a zero of J_0

The general solution is a linear combination of this eigenfunction for all zeros of J_0 , hence

$$u(r, t) = \sum_{m=1}^{\infty} c_m J_0(k_m r) e^{-\alpha^2 k_m^2 t} \quad (13)$$

We find c_m by using initial condition. When $t = 0$, temp. was 100^0 hence

$$100 = \sum_{m=1}^{\infty} c_m J_0(k_m r)$$

Applying inner product w.r.t. $rJ_0(k_u r)$ from 0 ... 1

$$\begin{aligned} \int_0^1 100 rJ_0(k_u r) dr &= \int_0^1 \left(\sum_{m=1}^{\infty} c_m J_0(k_m r) \right) rJ_0(k_u r) dr \\ 100 \int_0^1 rJ_0(k_u r) dr &= \sum_{m=1}^{\infty} c_m \int_0^1 J_0(k_m r) rJ_0(k_u r) dr \end{aligned}$$

From orthogonality of $J_0(k_m r)$ and $J_0(k_u r)$, all terms drop except when $m = u$

$$100 \int_0^1 rJ_0(k_u r) dr = c_u \int_0^1 r[J_0(k_u r)]^2 dr$$

From here we can follow the book on page 561 to get

$$c_m = \frac{200}{k_m J_1(k_m)}$$

Substitute this in equation 13

$$\begin{aligned} u(r, t) &= \sum_{m=1}^{\infty} c_m J_0(k_m r) e^{-\alpha^2 k_m^2 t} \\ &= \sum_{m=1}^{\infty} \frac{200}{k_m J_1(k_m)} J_0(k_m r) e^{-\alpha^2 k_m^2 t} \\ &= 200 \sum_{m=1}^{\infty} \frac{1}{k_m J_1(k_m)} J_0(k_m r) e^{-\alpha^2 k_m^2 t} \end{aligned}$$

Where k_m are zeros of J_0

Notice that final solution does not depend on θ

4.9.8 chapter 13, problem 5.11. Mary Boas, second edition

Solve

$$r \frac{d}{dr} \left(r \frac{dR}{dr} \right) = n^2 R$$

$$\frac{d}{dr} \left(r^2 \frac{dR}{dr} \right) = l(l+1)R$$

Solution

First equation, use power series method.

$$r \frac{d}{dr} \left(r \frac{dR}{dr} \right) = n^2 R$$

$$r \left(r \frac{d^2 R}{dr^2} + \frac{dR}{dr} \right) - n^2 R = 0$$

$$r^2 \frac{d^2 R}{dr^2} + r \frac{dR}{dr} - n^2 R = 0$$

Let $R = a_0 r^s + a_1 r^{s+1} + a_2 r^{s+2} + a_3 r^{s+3} + a_4 r^{s+4} + \dots$ then

$$R = a_0 r^s + a_1 r^{s+1} + a_2 r^{s+2} + a_3 r^{s+3} + a_4 r^{s+4} + \dots$$

$$-n^2 R = -n^2 a_0 r^s - n^2 a_1 r^{s+1} - n^2 a_2 r^{s+2} - n^2 a_3 r^{s+3} - n^2 a_4 r^{s+4} - \dots$$

$$\frac{dR}{dr} = s a_0 r^{s-1} + (s+1) a_1 r^s + (s+2) a_2 r^{s+1} + (s+3) a_3 r^{s+2} + \dots$$

$$r \frac{dR}{dr} = s a_0 r^s + (s+1) a_1 r^{s+1} + (s+2) a_2 r^{s+2} + (s+3) a_3 r^{s+3} + \dots$$

$$\frac{d^2 R}{dr^2} = (s-1)s a_0 r^{s-2} + s(s+1) a_1 r^{s-1} + (s+1)(s+2) a_2 r^s + (s+2)(s+3) a_3 r^{s+1} + \dots$$

$$r^2 \frac{d^2 R}{dr^2} = (s-1)s a_0 r^s + s(s+1) a_1 r^{s+1} + (s+1)(s+2) a_2 r^{s+2} + (s+2)(s+3) a_3 r^{s+3} + \dots$$

Table is

	r^s	r^{s+1}	r^{s+2}	r^{s+m}
$-n^2 R$	$-n^2 a_0$	$-n^2 a_1$	$-n^2 a_2$	$-n^2 a_m$
$r \frac{dR}{dr}$	$s a_0$	$(s+1) a_1$	$(s+2) a_2$	$(s+m) a_m$
$r^2 \frac{d^2 R}{dr^2}$	$(s-1)s a_0$	$s(s+1) a_1$	$(s+1)(s+2) a_2$	$(s+m-1)(s+m) a_m$

Hence, from first column we see , and since $a_0 \neq 0$ we solve for s

$$\begin{aligned} -n^2 a_0 + s a_0 + (s - 1)s a_0 &= 0 \\ a_0(-n^2 + s + (s - 1)s) &= 0 \\ -n^2 + s + (s - 1)s &= 0 \\ -n^2 + s^2 &= 0 \\ s &= \pm n \end{aligned}$$

We see from second column, $a_1(-n^2 + (s + 1) + s^2 + s) = 0$ or $a_1(-s^2 + 2s + 1 + s^2) = 0$, hence $a_1(2s + 1) = 0$

For $a_1 \neq 0$ then $s = -\frac{1}{2}$, this means n is not an integer since $s = \pm n$. hence a_1 must be zero.

The same applies to all $a_m, m > 0$ Hence solution contains only a_0

$$R = a_0 r^{\pm n}$$

$$R = \begin{cases} a_0 r^{-n} \\ a_0 r^{+n} \end{cases}$$

For some constant a_0 . This solution is when $n \neq 0$

If $n = 0$, table is

	r^s	r^{s+1}	r^{s+2}	r^{s+m}
$-n^2 R$	0	0	0	0
$r \frac{dR}{dr}$	$s a_0$	$(s + 1) a_1$	$(s + 2) a_2$	$(s + m) a_m$
$r^2 \frac{d^2 R}{dr^2}$	$(s - 1)s a_0$	$s(s + 1) a_1$	$(s + 1)(s + 2) a_2$	$(s + m - 1)(s + m) a_m$

From first column:

$$\begin{aligned} s a_0 + s^2 a_0 - s a_0 &= 0 \\ a_0(s + s^2 - s) &= 0 \\ s^2 &= 0 \\ s &= 0 \end{aligned}$$

And all other a 's are zero. Hence $R = a_0$ or R is constant.

Now for the second ODE

$$\frac{d}{dr} \left(r^2 \frac{dR}{dr} \right) = l(l+1)R$$

$$r^2 \frac{d^2R}{dr^2} + 2r \frac{dR}{dr} - l(l+1)R = 0$$

Let $R = a_0 r^s + a_1 r^{s+1} + a_2 r^{s+2} + a_3 r^{s+3} + a_4 r^{s+4} + \dots$ then

$$R = a_0 r^s + a_1 r^{s+1} + a_2 r^{s+2} + a_3 r^{s+3} + a_4 r^{s+4} + \dots$$

$$-l(l+1)R = -l(l+1)a_0 r^s - l(l+1)a_1 r^{s+1} - l(l+1)a_2 r^{s+2} - l(l+1)a_3 r^{s+3} - l(l+1)a_4 r^{s+4} - \dots$$

$$\frac{dR}{dr} = s a_0 r^{s-1} + (s+1) a_1 r^s + (s+2) a_2 r^{s+1} + (s+3) a_3 r^{s+2} + \dots$$

$$2r \frac{dR}{dr} = 2s a_0 r^s + 2(s+1) a_1 r^{s+1} + 2(s+2) a_2 r^{s+2} + 2(s+3) a_3 r^{s+3} + \dots$$

$$\frac{d^2R}{dr^2} = (s-1)s a_0 r^{s-2} + s(s+1) a_1 r^{s-1} + (s+1)(s+2) a_2 r^s + (s+2)(s+3) a_3 r^{s+1} + \dots$$

$$r^2 \frac{d^2R}{dr^2} = (s-1)s a_0 r^s + s(s+1) a_1 r^{s+1} + (s+1)(s+2) a_2 r^{s+2} + (s+2)(s+3) a_3 r^{s+3} + \dots$$

Table is

	r^s	r^{s+1}	r^{s+2}	r^{s+m}
$-l^2 R$	$-l(l+1)a_0$	$-l(l+1)a_1$	$-l(l+1)a_2$	$-l(l+1)a_m$
$2r \frac{dR}{dr}$	$2s a_0$	$2(s+1) a_1$	$2(s+2) a_2$	$2(s+m)a_m$
$r^2 \frac{d^2R}{dr^2}$	$(s-1)s a_0$	$s(s+1) a_1$	$(s+1)(s+2) a_2$	$(s+m-1)(s+m) a_m$

From first column:

$$-l(l+1)a_0 + 2s a_0 + (s-1)s a_0 = 0$$

$$a_0(-l(l+1) + 2s + (s-1)s) = 0$$

$$-l(l+1) + 2s + (s-1)s = 0$$

$$-l(l+1) + s + s^2 = 0$$

$$(s-l)(s-(-l-1)) = 0$$

Hence $s = l$ or $s = -l - 1$.

We also see that all other a 's will be zero, since recursive formula has only a_m in it and no other a . Hence

$$R = a_0 r^s$$
$$R = \begin{cases} a_0 r^l \\ a_0 r^{-l-1} \end{cases}$$

For some constant a_0

4.10 HW 10

Local contents

4.10.1	chapter 13, problem 6.3 Mary Boas, second edition	261
4.10.2	chapter 13, problem 7.2 Mary Boas, second edition	267
4.10.3	chapter 13, problem 7.15 Mary Boas, second edition	269
4.10.4	chapter 13, problem 7.16 Mary Boas, second edition	272
4.10.5	chapter 13, problem 7.17 Mary Boas, second edition	276
4.10.6	chapter 13, problem 8.1, Mary Boas, second edition.	277
4.10.7	chapter 13, problem 8.2 Mary Boas, second edition	278
4.10.8	chapter 13, problem 8.3, Mary Boas, second edition.	280

4.10.1 chapter 13, problem 6.3 Mary Boas, second edition

Problem

(my note: I'll use f for frequency instead of book ν (μ)) since ν looks very close to v the speed of the wave, to avoid confusion).

Separate the wave equation in 2D rectangular coordinates. Consider the membrane shown, rigidly attached to its supports along the sides. Show that its characteristic frequencies

are $f_{nm} = \left(\frac{v}{2}\right) \sqrt{\left(\frac{n}{a}\right)^2 + \left(\frac{m}{b}\right)^2}$ where n, m are positive integers and sketch the normal modes of vibration corresponding to the first few frequencies. Next suppose the membrane is square, show that in this case there may be two or more normal modes of vibration corresponding to a single frequency. Sketch several normal modes giving rise to the same frequency.

Solution

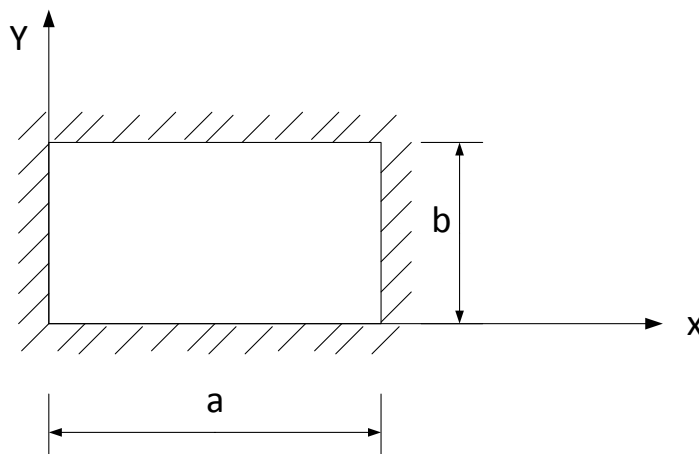

Wave equation in rectangular coordinates is $\frac{\partial^2 z}{\partial x^2} + \frac{\partial^2 z}{\partial y^2} = \frac{1}{v} \frac{\partial^2 z}{\partial t^2}$

Let solution

$$z(x, y, t) = X(x)Y(y)T(t)$$

Then we get after substitution

$$YTX'' + XTY'' = \frac{1}{v}XYT''$$

Divide by YTX we get

$$\frac{X''}{X} + \frac{Y''}{Y} = \frac{1}{v} \frac{T''}{T}$$

Each term above is a constant since no one term depend on more than one variable in the others.

So, $\frac{X''}{X} = \text{constant}$, $\frac{Y''}{Y} = \text{constant}$, $\frac{1}{v} \frac{T''}{T} = \text{constant}$

Let $\frac{X''}{X} = -k_x^2$

Let $\frac{Y''}{Y} = -k_y^2$

So $\frac{1}{v} \frac{T''}{T} = -k_x^2 - k_y^2 = -k_t^2$

So the 3 ODE equations are

$$\frac{X''}{X} = -k_x^2 \quad (1)$$

$$\frac{Y''}{Y} = -k_y^2 \quad (2)$$

$$\frac{1}{v^2} \frac{T''}{T} = -k_x^2 - k_y^2 = -(k_x^2 + k_y^2) = -v^2(k_x^2 + k_y^2) \quad (3)$$

equation (1) is an ODE whose solution is cos, sin

$$X(x) = \begin{cases} \cos k_x x \\ \sin k_x x \end{cases}$$

Similarly

$$Y(y) = \begin{cases} \cos k_y y \\ \sin k_y y \end{cases}$$

similarly

$$T(t) = \begin{cases} \cos\left(t\sqrt{v^2(k_x^2 + k_y^2)}\right) \\ \sin\left(t\sqrt{v^2(k_x^2 + k_y^2)}\right) \end{cases}$$

Hence the general solution is

$$z(x, y, t) = \begin{cases} \cos k_x x \\ \sin k_x x \end{cases} \begin{cases} \cos k_y y \\ \sin k_y y \end{cases} \begin{cases} \cos\left(t\sqrt{v^2(k_x^2 + k_y^2)}\right) \\ \sin\left(t\sqrt{v^2(k_x^2 + k_y^2)}\right) \end{cases}$$

So we have a total of 6 possible general solutions

Now apply boundary conditions to remove solutions that can not be fitted.

Since membrane is fixed at $y = 0$, then we want $z = 0$ when $y = 0$ hence we reject the $\cos k_y y$ since that is not zero at $y = 0$

And since we want $z = 0$ when $x = 0$ hence we reject the $\cos k_x x$ since that is not zero at $x = 0$

So now our solution looks like

$$z(x, y, t) = \sin(k_x x) \sin(k_y y) \begin{cases} \cos\left(t\sqrt{v^2(k_x^2 + k_y^2)}\right) \\ \sin\left(t\sqrt{v^2(k_x^2 + k_y^2)}\right) \end{cases}$$

Now need to find k_x and k_y

Since membrane is also fixed at $y = b$ then we want $z = 0$ when $y = b$. hence we want $\sin(k_y b) = 0$ then happens when $k_y b = m\pi$ for an integer m

So

$$k_y = \frac{m\pi}{b}$$

The same for k_x we want $z = 0$ when $x = a$. hence we want $\sin(k_x a) = 0$ then happens when $k_x a = n\pi$ for some integer n , so

$$k_x = \frac{n\pi}{a}$$

Hence the general solution now looks like

$$z(x, y, t) = \sin\left(\frac{n\pi}{a}x\right) \sin\left(\frac{m\pi}{b}y\right) \begin{cases} \cos\left(vt\sqrt{\left(\frac{n\pi}{a}\right)^2 + \left(\frac{m\pi}{b}\right)^2}\right) \\ \sin\left(vt\sqrt{\left(\frac{n\pi}{a}\right)^2 + \left(\frac{m\pi}{b}\right)^2}\right) \end{cases}$$

$$z(x, y, t) = \sin\left(\frac{n\pi}{a}x\right) \sin\left(\frac{m\pi}{b}y\right) \begin{cases} \cos\left(\pi vt\sqrt{\left(\frac{n}{a}\right)^2 + \left(\frac{m}{b}\right)^2}\right) \\ \sin\left(\pi vt\sqrt{\left(\frac{n}{a}\right)^2 + \left(\frac{m}{b}\right)^2}\right) \end{cases} \quad (4)$$

Now, from the general form of a wave equation, which can be written as $z = A \cos(\omega t)$ or $A \sin(\omega t)$ where ω is the angular velocity in radian per second.

Hence by comparing to above, we see that

$$\pi vt\sqrt{\left(\frac{n}{a}\right)^2 + \left(\frac{m}{b}\right)^2} = \omega t$$

$$\pi v\sqrt{\left(\frac{n}{a}\right)^2 + \left(\frac{m}{b}\right)^2} = \omega$$

but $\omega = 2\pi f$ where f is the frequency in hertz or cycles per seconds.

hence

$$f = \frac{v}{2} \sqrt{\left(\frac{n}{a}\right)^2 + \left(\frac{m}{b}\right)^2}$$

Which is what we are required to show.

To plot the normal modes of vibrations, need to find where the solutions are zero as I modify n, m . from (4), looking at the space components of the solution since that is what is of interest here,

$$z(x, y) = \sin\left(\frac{n\pi}{a}x\right) \sin\left(\frac{m\pi}{b}y\right)$$

For $n = 1, m = 1$

$$z(x, y, t) = \sin\left(\frac{\pi}{a}x\right) \sin\left(\frac{\pi}{b}y\right)$$

This is zero when $x = a$ or $y = b$ hence the whole membrane will vibrate internally except at boundaries.

$$n = 2, m = 1$$

$$z(x, y, t) = \sin\left(\frac{2\pi}{a}x\right) \sin\left(\frac{\pi}{b}y\right)$$

This is zero when $x = a$ and $x = \frac{a}{2}$ or $y = b$ Hence we have a normal mode at line $x = a/2$ (see diagram below).

$$n = 3, m = 1$$

$$z(x, y, t) = \sin\left(\frac{3\pi}{a}x\right) \sin\left(\frac{\pi}{b}y\right)$$

This is zero when $x = a$ and $x = \frac{a}{3}, x = \frac{2a}{3}$ or $y = b$ Hence we have a normal mode at line $x = a/3$ and $x = \frac{2a}{3}$ line (see diagram below).

$$n = 1, m = 2$$

$$z(x, y, t) = \sin\left(\frac{\pi}{a}x\right) \sin\left(\frac{2\pi}{b}y\right)$$

This is zero when $x = a$ and or $y = \frac{b}{2}$ Hence we have a normal mode at line $y = \frac{b}{2}$ line (see diagram below).

$$n = 1, m = 3$$

$$z(x, y, t) = \sin\left(\frac{\pi}{a}x\right) \sin\left(\frac{3\pi}{b}y\right)$$

This is zero when $x = a$ or $y = b$ and $y = \frac{b}{3}, y = \frac{2b}{3}$ Hence we have a normal mode at line $y = b/3$ and $y = \frac{2b}{3}$ line (see diagram below).

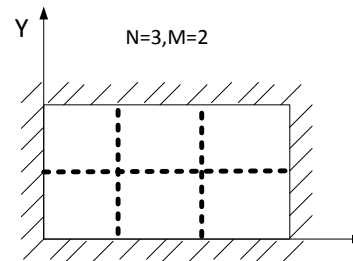
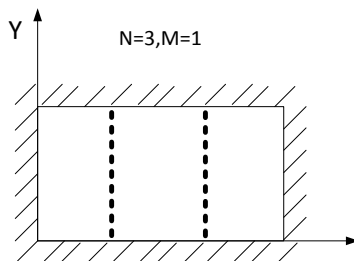
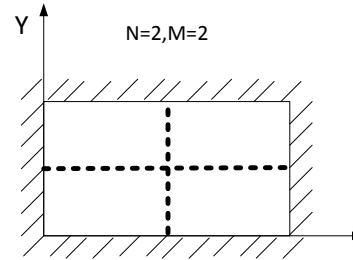
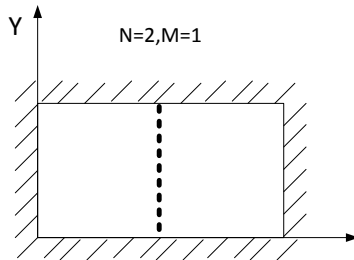
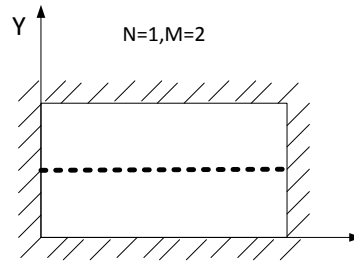
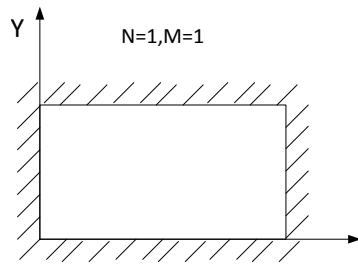

When the membrane is square, we have $a = b$ hence the solution becomes

$$z(x, y, t) = \sin\left(\frac{n\pi}{a}x\right) \sin\left(\frac{m\pi}{a}y\right) \begin{cases} \cos\left(\pi vt \sqrt{\left(\frac{n}{a}\right)^2 + \left(\frac{m}{a}\right)^2}\right) \\ \sin\left(\pi vt \sqrt{\left(\frac{n}{a}\right)^2 + \left(\frac{m}{a}\right)^2}\right) \end{cases}$$

So, the frequency of the wave in the membrane takes values of

$$f = \frac{v}{2} \sqrt{\left(\frac{n}{a}\right)^2 + \left(\frac{m}{a}\right)^2}$$

$$f = \frac{v}{2a} \sqrt{n^2 + m^2}$$

This shows that for example, for $n = 7$ and $m = 1$ we will get the same frequencies as for $n = 1$ and $m = 7$. hence we will get two or more modes of vibrations for the same frequency.

4.10.2 chapter 13, problem 7.2 Mary Boas, second edition

Find steady state temp. distribution inside a sphere of $r = 1$ when the surface temp. is $u = \cos \theta - (\cos \theta)^3$

Solution

Need to use Laplace equation here. The basic solution to this problem is derived and given in text book at page 568

$$u(r, \theta, \phi) = r^l P_l^m(\cos \theta) \begin{cases} \sin m\phi \\ \cos m\phi \end{cases} \quad (1)$$

Where l is a constant (one that occurs in associated Legendre equation, equation 10.1 in text, page 504):

$$(1 - x^2)y'' - 2xy' + \left[l(l+1) - \frac{m^2}{1-x^2} \right] y = 0$$

and $P_l^m(x)$ is the associated Legendre functions (solution of the associated Legendre equation). and r, θ, ϕ are the spherical coordinates.

Since the temp. at the surface is a function of θ then I can not remove the dependency of the solution on θ as we have done in other problems. However, the solution is independent of ϕ so m must be zero, and we can drop that ϕ dependency, hence the basic solution becomes

$$u(r, \theta) = r^l P_l(\cos \theta) \quad (2)$$

Since a general solution is a sum of these solutions, we get

$$u(r, \theta) = \sum_{l=0}^{\infty} c_l r^l P_l(\cos \theta) \quad (3)$$

When $r = 1$

$$u(1, \theta) = \cos \theta - (\cos \theta)^3 = \sum_{l=0}^{\infty} c_l r^l P_l(\cos \theta) \quad (4)$$

Writing $\cos \theta = x$, I see that $\cos \theta - (\cos \theta)^3 = x - x^3$ But $P_3(x) = \frac{-3}{2}x + \frac{5}{2}x^3$ and $P_1(x) = x$

Hence I need a combination of $P_3(x)$ and $P_1(x)$ which will add to $x - x^3$ so I can put that on the LHS of (4) to solve for the c_l

$$\text{Try } \frac{4}{10}P_1(x) - \frac{2}{5}P_3(x) = \frac{4}{10}(x) - \frac{2}{5}\left(\frac{-3}{2}x + \frac{5}{2}x^3\right) = \frac{4}{10}x + \frac{6}{10}x - x^3 = x - x^3$$

Which is what we want.

Hence (4) can be written as

$$u(1, \theta) = \frac{2}{5}P_1(\cos \theta) - \frac{2}{5}P_3(\cos \theta) = \sum_{l=0}^{\infty} c_l r^l P_l(\cos \theta) \quad (5)$$

Expanding the sum and compare c_l I only need to go up to $l = 3$

$$\frac{2}{5}P_1(\cos \theta) - \frac{2}{5}P_3(\cos \theta) = c_0 r^0 P_0(\cos \theta) + c_1 r^1 P_1(\cos \theta) + c_2 r^2 P_2(\cos \theta) + c_3 r^3 P_3(\cos \theta)$$

Hence

$$c_1 = \frac{2}{5}$$

$$c_3 = -\frac{2}{5}$$

All other c_l are zero

So final solution from (3) is

$$u(r, \theta) = \sum_{l=0}^{\infty} c_l r^l P_l(\cos \theta)$$

$$= \frac{2}{5} r P_1(\cos \theta) - \frac{2}{5} r^3 P_3(\cos \theta)$$

4.10.3 chapter 13, problem 7.15 Mary Boas, second edition

r in (1.9) should be included. Replace $c_1 r$ in (1.11) by $(a_1 r + b_1 r^{-1})$.

15. A sphere initially at 0° has its surface kept at 100° from $t = 0$ on (for example, a frozen potato in boiling water!). Find the time-dependent temperature distribution. *Hint*: Subtract 100° from all temperatures and solve the problem; then add the 100° to the answer. Can you justify this procedure? Show that the Legendre function required for this problem is P_0 and the r solution is $(1/\sqrt{r})J_{1/2}$ or j_0 [see (17.4) in Chapter 12]. Since spherical Bessel functions can be expressed in terms of elementary functions, the series in this problem can be thought of as either a Bessel series or a Fourier series. Show that the results are identical.

Figure 4.1: the Problem statement

Solution

Since we want the time-dependent solution, we use the heat diffusion equation

$$\nabla^2 u = \frac{1}{\alpha^2} \frac{\partial u}{\partial t}$$

The heat equation in spherical coordinates is given by equation 7.5 on page 567, plus an additional term called λ as was derived in class lecture, where $\lambda = k^2 \alpha^2$, and $T(t) = e^{-k^2 \alpha^2 t}$. Hence the equation is

$$\frac{1}{R(r)} \frac{d}{dr} \left(r^2 \frac{dR}{dr} \right) + \frac{1}{\Theta \sin \theta} \frac{d}{d\theta} \left(\sin \theta \frac{d\Theta}{d\theta} \right) - \frac{m^2}{\sin^2 \theta} + (k^2 \alpha^2) r^2 = 0$$

Where m is a constant to make $\Phi(\phi)$ periodic as per page 567 in text. Using separation of variables we obtained as per lecture notes, the general solution is

$$u(r, \theta, \phi, t) = e^{-(k^2 \alpha^2) t} \begin{cases} \cos m\phi \\ \sin m\phi \end{cases} P_l^m(\cos \theta) \overbrace{\frac{1}{\sqrt{r}} J_{l+\frac{1}{2}}(kr)}^{R(r) \text{ solution}} \quad (1)$$

But from book, equation 17.4, on page 518, we have $j_l(r) = \sqrt{\frac{1}{r}} J_{l+\frac{1}{2}}(r)$ Where $j_l(r)$ is the spherical Bessel function, then $j_l(kr) = \sqrt{\frac{1}{r}} J_{l+\frac{1}{2}}(kr)$, so (1) is written in terms of spherical Bessel functions as

$$u(r, \theta, \phi, t) = e^{-(k^2 \alpha^2)t} \begin{cases} \cos m\phi \\ \sin m\phi \end{cases} P_l^m(\cos \theta) j_l(kr) \quad (2)$$

Equation (2) is the general solution of heat equation for spherical coordinates.

Since of symmetry w.r.t. θ and ϕ in the solution (since sphere surface temp does not depend on θ nor ϕ), we can drop the terms that depends on θ by setting $m = 0$, and set $l = 0$ since we do not want singularity at origin which we assumed in the center of the sphere, therefore (2) becomes

$$u(r, t) = e^{-(k^2 \alpha^2)t} j_0(kr) \quad (3)$$

Now, $u = 0$ for time $t > 0$ when $r = L$, where $L = \text{radius of the sphere}$, hence for this to occur, $j_0(kL)$ must be zero, so we want kL to be the zeros of the spherical coordinate function. Since $j_0(x) = \frac{\sin x}{x}$ (from equation 17.4 page 518), then we see that $j_0(kL) = 0$ implies $\sin(kL) = 0$ or $kL = n\pi$ or $k = \frac{n\pi}{L}$ for integer n .

Hence now (3) becomes

$$\begin{aligned} u(r, t) &= e^{-\left(\left(\frac{n\pi}{L}\right)^2 \alpha^2\right)t} j_0\left(\frac{n\pi}{L}r\right) \\ &= e^{-\left(\frac{n\pi}{L}\alpha\right)^2 t} j_0\left(\frac{n\pi r}{L}\right) \end{aligned} \quad (4)$$

This is the basic candidate solution, which is in terms of j_0 as is required to show. The general solution is a sum of these solutions

$$u(r, t) = \sum c_n e^{-\left(\left(\frac{n\pi}{L}\right)^2 \alpha^2\right)t} j_0\left(\frac{n\pi}{L}r\right)$$

Write j in terms of sin since easier to deal with. (equation 17.4 in book)

$$\begin{aligned} u(r, t) &= \sum c_n e^{-\left(\left(\frac{n\pi}{L}\right)^2 \alpha^2\right)t} \frac{\sin \frac{n\pi r}{L}}{\frac{n\pi r}{L}} \\ u(r, t) &= \sum c_n \frac{L}{n\pi r} e^{-\left(\frac{n\pi}{L}\alpha\right)^2 t} \sin \frac{n\pi r}{L} \\ u(r, t) &= \sum z_n \frac{1}{r} e^{-\left(\frac{n\pi}{L}\alpha\right)^2 t} \sin \frac{n\pi r}{L} \end{aligned} \quad (5)$$

where z_n is a new constant. Now, set $u = -100$ at time $t = 0$ as in the hint, and since final solution is a sum of the above solution (4), then we get

$$\begin{aligned} -100 &= \sum z_n \frac{1}{r} \sin \frac{n\pi r}{L} \\ -100 r &= \sum z_n \sin \frac{n\pi r}{L} \end{aligned}$$

Now we need to find z_n . Taking inner product w.r.t. $\sin \frac{m\pi r}{L}$, all terms on the RHS vanish except for when $n = m$

$$\begin{aligned} -100 \int_{r=0}^{r=L} r \sin \frac{n\pi r}{L} dr &= \int_0^L \left(\sum_{m=0}^{\infty} z_m \sin \left(\frac{m\pi r}{L} \right) \right) \sin \frac{n\pi r}{L} dr \\ -100 \left[\frac{L^2(-n\pi \cos(n\pi) + \sin(n\pi))}{n^2\pi^2} \right] &= \int_0^L c_n \sin^2 \left(\frac{n\pi r}{L} \right) dr \\ 100 \left[\frac{L^2 n\pi \cos(n\pi)}{n^2\pi^2} \right] &= z_n \int_0^L \sin^2 \left(\frac{n\pi r}{L} \right) dr \\ 100 \left[\frac{L^2 \cos(n\pi)}{n\pi} \right] &= z_n \frac{L}{2} \\ 200 \left[\frac{L \cos(n\pi)}{n\pi} \right] &= z_n \\ 200 \frac{L}{n\pi} \cos(n\pi) &= z_n \\ 200 \frac{L}{n\pi} (-1)^n &= z_n \end{aligned}$$

Substituting into (5) gives

$$\begin{aligned} u(r, t) &= \sum \left[200 \frac{L}{n\pi} (-1)^n \right] \frac{1}{r} e^{-\left(\frac{n\pi}{L}\alpha\right)^2 t} \sin \frac{n\pi r}{L} \\ u(r, t) &= \frac{200L}{\pi r} \sum \frac{1}{n} (-1)^n e^{-\left(\frac{n\pi}{L}\alpha\right)^2 t} \sin \frac{n\pi r}{L} \end{aligned}$$

Now adding the 100 which was subtracted at the start, hence the final solution is

$$u(r, t) = 100 + \frac{200L}{\pi r} \sum \frac{1}{n} (-1)^n e^{-\left(\frac{n\pi}{L}\alpha\right)^2 t} \sin \frac{n\pi r}{L}$$

To verify, setting $r = L$ gives

$$\begin{aligned}
 u(L, t) &= 100 + \frac{200L}{\pi r} \sum \frac{1}{n} (-1)^n e^{-\left(\frac{n\pi}{L}\alpha\right)^2 t} \sin \frac{n\pi L}{L} \\
 &= 100 + 0 \\
 &= 100
 \end{aligned}$$

Which is the correct boundary condition for $t > 0$.

Another way to solve the above is to not convert j_0 to sin function, and use the orthogonality based on the spherical Bessel functions to find the coefficients. The same answer will be obtained.

4.10.4 chapter 13, problem 7.16 Mary Boas, second edition

Separate the wave equation in spherical coordinates and show that the θ, ϕ solutions are the spherical harmonics $P_l^m(\cos \theta)e^{\pm im\phi}$ and the r solutions are spherical Bessel functions $j_l(kr)$ and $y_l(kr)$

Solution

Since we want the wave equation

$$\nabla^2 u = \frac{1}{v^2} \frac{\partial^2 u}{\partial t^2}$$

Using the spherical Laplacian operator, the wave equation is written as

$$\frac{1}{r^2} \frac{\partial}{\partial r} \left(r^2 \frac{\partial u}{\partial r} \right) + \frac{1}{r^2} \frac{1}{\sin \theta} \frac{\partial}{\partial \theta} \left(\sin \theta \frac{\partial u}{\partial \theta} \right) + \frac{1}{r^2 \sin^2 \theta} \frac{\partial^2 u}{\partial \phi^2} = \frac{1}{v^2} \frac{\partial^2 u}{\partial t^2}$$

Let

$$u(r, \theta, \phi, t) = R(r)\Theta(\theta)\Phi(\phi)T(t)$$

Substituting into the wave equation and multiplying by $\frac{1}{R(r)\Theta(\theta)\Phi(\phi)T(t)}$

$$\frac{1}{R} \frac{1}{r^2} \frac{d}{dr} \left(r^2 \frac{dR}{dr} \right) + \frac{1}{\Theta} \frac{1}{r^2} \frac{1}{\sin \theta} \frac{d}{d\theta} \left(\sin \theta \frac{d\Theta}{d\theta} \right) + \frac{1}{r^2 \sin^2 \theta} \frac{1}{\Phi} \frac{d^2 \Phi}{d\phi^2} = \frac{1}{v^2} \frac{1}{T} \frac{d^2 T}{dt^2} \quad (1)$$

Applying variable separation. Multiplying (1) by $r^2 \sin^2 \theta$ gives

$$\frac{\sin \theta}{R} \frac{d}{dr} \left(r^2 \frac{dR}{dr} \right) + \frac{1}{\Theta} \sin \theta \frac{d}{d\theta} \left(\sin \theta \frac{d\Theta}{d\theta} \right) + \overbrace{\frac{1}{\Phi} \frac{d^2 \Phi}{d\phi^2}} = \frac{r^2 \sin^2 \theta}{v^2} \frac{1}{T} \frac{d^2 T}{dt^2}$$

The last term on the LHS is a constant. Therefore $\frac{1}{\Phi} \frac{d^2\Phi}{d\phi^2}$ is a constant, say $-m^2$, hence

$$\Phi = \begin{cases} \sin m\phi \\ \cos m\phi \end{cases} \quad (2)$$

And (1) becomes

$$\frac{1}{R} \frac{1}{r^2} \frac{d}{dr} \left(r^2 \frac{dR}{dr} \right) + \frac{1}{\Theta} \frac{1}{r^2} \frac{1}{\sin \theta} \frac{d}{d\theta} \left(\sin \theta \frac{d\Theta}{d\theta} \right) + \frac{-m^2}{r^2 \sin^2 \theta} = \overbrace{\frac{1}{v^2} \frac{1}{T} \frac{d^2 T}{dt^2}} \quad (1A)$$

Now separating the Time solution. The RHS does not depend on r, θ, ϕ , and is equal to something that does. Hence it is a constant. Say $-k^2$, therefore

$$\frac{1}{v^2} \frac{1}{T} \frac{d^2 T}{dt^2} = -k^2$$

The above do not need to be solved as not required by problem, however its solution is

$$\begin{aligned} \frac{d^2 T}{dt^2} &= -v^2 k^2 T \\ \frac{d^2 T}{dt^2} + v^2 k^2 T &= 0 \\ T(t) &= Ae^{ikvt} + Be^{-ikvt} \end{aligned}$$

Now (1A) becomes

$$\begin{aligned} \frac{1}{R} \frac{1}{r^2} \frac{d}{dr} \left(r^2 \frac{dR}{dr} \right) + \frac{1}{\Theta} \frac{1}{r^2} \frac{1}{\sin \theta} \frac{d}{d\theta} \left(\sin \theta \frac{d\Theta}{d\theta} \right) + \frac{-m^2}{r^2 \sin^2 \theta} &= -k^2 \\ \frac{1}{R} \frac{1}{r^2} \frac{d}{dr} \left(r^2 \frac{dR}{dr} \right) + \frac{1}{\Theta} \frac{1}{r^2} \frac{1}{\sin \theta} \frac{d}{d\theta} \left(\sin \theta \frac{d\Theta}{d\theta} \right) + \frac{-m^2}{r^2 \sin^2 \theta} + k^2 &= 0 \end{aligned} \quad (1B)$$

Separating the θ solution. multiplying (1B) by r^2 gives

$$\frac{1}{R} \frac{d}{dr} \left(r^2 \frac{dR}{dr} \right) + \overbrace{\frac{1}{\Theta} \frac{1}{\sin \theta} \frac{d}{d\theta} \left(\sin \theta \frac{d\Theta}{d\theta} \right) + \frac{-m^2}{\sin^2 \theta}} + r^2 k^2 = 0 \quad (1C)$$

The bracketed term is a constant, hence

$$\frac{1}{\Theta} \frac{1}{\sin \theta} \frac{d}{d\theta} \left(\sin \theta \frac{d\Theta}{d\theta} \right) - \frac{m^2}{\sin^2 \theta} = -\zeta$$

$$\frac{1}{\Theta} \frac{1}{\sin \theta} \frac{d}{d\theta} \left(\sin \theta \frac{d\Theta}{d\theta} \right) - \frac{m^2}{\sin^2 \theta} + \zeta = 0$$

$$\frac{1}{\sin \theta} \frac{d}{d\theta} \left(\sin \theta \frac{d\Theta}{d\theta} \right) - \frac{m^2}{\sin^2 \theta} \Theta + \zeta \Theta = 0$$

As per page 568 in text book, the above is the equation for the associated Legendre functions if $\zeta = l(l+1)$ The solution is given by

$$\Theta = P_l^m(\cos \theta) \quad (4)$$

Hence the θ, ϕ solutions are given by equations (3) and (4)

$$\begin{aligned} &= P_l^m(\cos \theta) \begin{cases} \sin m\phi \\ \cos m\phi \end{cases} \\ &= P_l^m(\cos \theta) e^{\pm im\phi} \end{aligned}$$

Which is what we are required to show.

(1C) now becomes

$$\frac{1}{R} \frac{d}{dr} \left(r^2 \frac{dR}{dr} \right) - \zeta + r^2 k^2 = 0$$

For the radial solution, from equation above for radial equation:

$$\begin{aligned} &\frac{d}{dr} \left(r^2 \frac{dR}{dr} \right) + R r^2 k^2 - R \zeta = 0 \\ r^2 \frac{d^2 R}{dr^2} + 2r \frac{dR}{dr} + R r^2 k^2 - R \zeta &= 0 \end{aligned}$$

Dividing by r^2

$$\begin{aligned}\frac{d^2R}{dr^2} + \frac{2}{r} \frac{dR}{dr} + R k^2 - R \frac{\zeta}{r^2} &= 0 \\ \frac{d^2R}{dr^2} + \frac{2}{r} \frac{dR}{dr} + \left(k^2 - \frac{\zeta}{r^2} \right) R &= 0\end{aligned}\quad (5)$$

The above equation is of the form 16.1 on page 516:

$$y'' + \frac{1-2a}{x} y' + \left[(bcx^{c-1})^2 + \frac{a^2 - p^2 c^2}{x^2} \right] y = 0 \quad (16.1)$$

Whose solution is given by 16.2: $y = x^a Z_p(bx^c)$. Hence by comparison between 16.1 and (5) (and writing the independent variable x as r

$$\begin{aligned}\frac{1-2a}{r} &= \frac{2}{r} \\ (bcrc^{-1})^2 &= k^2 \\ \frac{a^2 - p^2 c^2}{r^2} &= -\frac{\zeta}{r^2}\end{aligned}$$

Therefore, $c = 1$, and $b = k$, $1 - 2a = 2 \rightarrow \boxed{a = \frac{1}{2}}$. And $a^2 - p^2 c^2 = -\zeta \Rightarrow \frac{1}{4} - p^2 = -\zeta \Rightarrow \boxed{p = \sqrt{\frac{1}{4} + \zeta}}$

So solution to radial component is

$$R = r^{\frac{1}{2}} Z_{\sqrt{\frac{1}{4} + \zeta}}(kr)$$

Where Z stands for J or N . Let $\sqrt{\frac{1}{4} + \zeta} = n$ some constant (since ζ is a constant). The solution is

$$R = \sqrt{r} J_n(kr)$$

Or

$$R = \sqrt{r} Y_n(kr)$$

From equation (17.4) we see that the J and Y Bessel function are related to the spherical Bessel function j and y , this means the radial solution $R(r)$ can be expressed in terms of the spherical Bessel functions.

4.10.5 chapter 13, problem 7.17 Mary Boas, second edition

Separate the Schrodinger equation $\nabla^2\psi + (\epsilon - bV)\psi = 0$ in spherical coordinates

Solution

V is function of r only, so we have

$$\nabla^2\psi(r, \theta, \phi) + (\epsilon - bV(r))\psi(r, \theta, \phi) = 0$$

Using the spherical Laplacian operator, the above equation is written as

$$\frac{1}{r^2} \frac{\partial}{\partial r} \left(r^2 \frac{\partial u}{\partial r} \right) + \frac{1}{r^2} \frac{1}{\sin \theta} \frac{\partial}{\partial \theta} \left(\sin \theta \frac{\partial u}{\partial \theta} \right) + \frac{1}{r^2 \sin^2 \theta} \frac{\partial^2 u}{\partial \phi^2} + (\epsilon - bV(r))\psi(r, \theta, \phi) = 0$$

Let

$$\psi(r, \theta, \phi) = R(r)\Theta(\theta)\Phi(\phi)$$

Substituting into the above equation and multiplying by $\frac{r^2}{R(r)\Theta(\theta)\Phi(\phi)}$ gives

$$\overbrace{\frac{1}{R} \frac{d}{dr} \left(r^2 \frac{dR}{dr} \right) + (\epsilon - bV(r)) r^2} + \frac{1}{\Theta} \frac{1}{\sin \theta} \frac{d}{d\theta} \left(\sin \theta \frac{d\Theta}{d\theta} \right) + \frac{1}{\Phi} \frac{1}{\sin^2 \theta} \frac{d^2\Phi}{d\phi^2} = 0 \quad (1)$$

The bracketed part above depends only on r and is equal to a function that does not depend on r , hence it must be constant. Calling it k , (1) becomes

$$k + \frac{1}{\Theta} \frac{1}{\sin \theta} \frac{d}{d\theta} \left(\sin \theta \frac{d\Theta}{d\theta} \right) + \frac{1}{\Phi} \frac{1}{\sin^2 \theta} \frac{d^2\Phi}{d\phi^2} = 0 \quad (2)$$

Multiplying by $\sin^2 \theta$ gives

$$k \sin^2 \theta + \frac{1}{\Theta} \sin \theta \frac{d}{d\theta} \left(\sin \theta \frac{d\Theta}{d\theta} \right) + \overbrace{\frac{1}{\Phi} \frac{d^2\Phi}{d\phi^2}} = 0$$

The bracketed part can be separated out $\frac{1}{\Phi} \frac{d^2\Phi}{d\phi^2} = -m^2$. Hence the solutions are

$$\Phi = \begin{cases} \sin m\phi \\ \cos m\phi \end{cases}$$

So now equation (2) becomes

$$k + \frac{1}{\Theta} \frac{1}{\sin \theta} \frac{d}{d\theta} \left(\sin \theta \frac{d\Theta}{d\theta} \right) - \frac{m^2}{\sin^2 \theta} = 0$$

$$\frac{1}{\sin \theta} \frac{d}{d\theta} \left(\sin \theta \frac{d\Theta}{d\theta} \right) - \frac{m^2}{\sin^2 \theta} \Theta + k\Theta = 0$$

As per page 568 in text book, this has a solution of $\Theta = P_l^m(\cos \theta)$. Hence the θ, ϕ solution is

$$P_l^m(\cos \theta)\Phi = \begin{cases} \sin m\phi \\ \cos m\phi \end{cases}$$

We notice that the angular solution are identical to the Laplace equation and expressed in terms of spherical harmonics.

4.10.6 chapter 13, problem 8.1, Mary Boas, second edition.

Show that gravitational potential $V(x, y, z) = -\frac{Gm}{r}$ satisfies Laplace equation

Solution

$$V(x, y, z) = -\frac{Gm}{r} = -\frac{Gm}{\sqrt{x^2 + y^2 + z^2}} = -Gm(x^2 + y^2 + z^2)^{-\frac{1}{2}}$$

Hence

$$\begin{aligned} \frac{\partial V}{\partial x} &= -Gm \left(-\frac{1}{2} \right) (x^2 + y^2 + z^2)^{-\frac{3}{2}} (2x) \\ &= Gm (x^2 + y^2 + z^2)^{-\frac{3}{2}} (x) \end{aligned}$$

$$\begin{aligned} \frac{\partial^2 V}{\partial x^2} &= Gm \left[(x^2 + y^2 + z^2)^{-\frac{3}{2}} \times 1 + x \left(-\frac{3}{2} (x^2 + y^2 + z^2)^{-\frac{5}{2}} (2x) \right) \right] \\ &= Gm \left[(x^2 + y^2 + z^2)^{-\frac{3}{2}} - 3x^2 (x^2 + y^2 + z^2)^{-\frac{5}{2}} \right] \end{aligned} \quad (1)$$

Similarly, we find

$$\frac{\partial^2 V}{\partial y^2} = Gm \left[(x^2 + y^2 + z^2)^{-\frac{3}{2}} - 3y^2(x^2 + y^2 + z^2)^{-\frac{5}{2}} \right] \quad (2)$$

And

$$\frac{\partial^2 V}{\partial z^2} = Gm \left[(x^2 + y^2 + z^2)^{-\frac{3}{2}} - 3z^2(x^2 + y^2 + z^2)^{-\frac{5}{2}} \right] \quad (3)$$

Add (1),(2),(3) we get

$$\begin{aligned} \frac{\partial^2 V}{\partial x^2} + \frac{\partial^2 V}{\partial y^2} + \frac{\partial^2 V}{\partial z^2} &= 3Gm (x^2 + y^2 + z^2)^{-\frac{3}{2}} - 3Gm (x^2 + y^2 + z^2)^{-\frac{5}{2}}(x^2 + y^2 + z^2) \\ \nabla^2 V(x, y, z) &= 3Gm (x^2 + y^2 + z^2)^{-\frac{3}{2}} - 3Gm (x^2 + y^2 + z^2)^{-\frac{3}{2}} \\ \nabla^2 V(x, y, z) &= 0 \end{aligned}$$

Hence $V(x, y, z)$ satisfies Laplace equation.

4.10.7 chapter 13, problem 8.2 Mary Boas, second edition

Using formulas in chapter 12 section 5, sum the series in 8.20 to get 8.21

Solution

Series in 8.20 is

$$q \sum_l \frac{R^{2l+1} P_l(\cos \theta)}{r^{l+1} a^{l+1}} \quad (8.20)$$

We want to show that the above can simplify to 8.21, which is

$$\frac{\frac{R}{a} q}{\sqrt{r^2 + \left(\frac{R^2}{a}\right)^2 - 2r\left(\frac{R^2}{a}\right) \cos \theta}} \quad (8.21)$$

Let $\frac{R^2}{ar} = h$ then $\frac{R^2}{a} = rh$, and $\frac{R}{a} = \frac{rh}{R}$ and $\cos \theta = x$

8.21 becomes

$$\begin{aligned} \frac{\frac{R}{a}q}{\sqrt{r^2 + \left(\frac{R^2}{a}\right)^2 - 2r\left(\frac{R^2}{a}\right)\cos\theta}} &= \frac{\frac{rh}{R}q}{\sqrt{r^2 + (rh)^2 - 2r(rh)x}} \\ &= \frac{\frac{rh}{R}q}{\sqrt{r^2 + r^2h^2 - 2r^2hx}} \\ &= \frac{\frac{rh}{R}q}{r\sqrt{1 + h^2 - 2hx}} \end{aligned}$$

From 5.1 on page 490, we see that $\Phi(x, h) = (1 - 2xh + h^2)^{-\frac{1}{2}}$

So the above equation becomes

$$\frac{\frac{R}{a}q}{\sqrt{r^2 + \left(\frac{R^2}{a}\right)^2 - 2r\left(\frac{R^2}{a}\right)\cos\theta}} = \frac{\frac{rh}{R}q}{r}\Phi(x, h)$$

Using 5.2, we expand the $\Phi(x, h)$ as $\sum_l h^l P_l(x)$

Hence

$$\begin{aligned} \frac{\frac{R}{a}q}{\sqrt{r^2 + \left(\frac{R^2}{a}\right)^2 - 2r\left(\frac{R^2}{a}\right)\cos\theta}} &= \frac{\frac{rh}{R}q}{r}\Phi(x, h) \\ &= \frac{hq}{R} \sum_l h^l P_l(x) \end{aligned}$$

Substitute back $\cos\theta = x$, and $\frac{R^2}{ar} = h$ in above we get

$$\begin{aligned}
\frac{\frac{R}{a}q}{\sqrt{r^2 + \left(\frac{R^2}{a}\right)^2 - 2r\left(\frac{R^2}{a}\right)\cos\theta}} &= \frac{\left(\frac{R^2}{ar}\right)q}{R} \sum_l \left(\frac{R^2}{ar}\right)^l P_l(x) \\
&= \frac{Rq}{ar} \sum_l \frac{R^{2l}}{a^l r^l} P_l(x) \\
&= q \sum_l \frac{R^{2l+1}}{a^{l+1} r^{l+1}} P_l(x)
\end{aligned}$$

Which is 8.20. Hence this shows that 8.20 can be simplified to 8.21

4.10.8 chapter 13, problem 8.3, Mary Boas, second edition.

Do the problem in example 1 for the case of a charge q inside a grounded sphere to obtain the potential V inside the sphere.

Solution

Starting the example from equation 8.15, which is the basic solution of Laplace in spherical coordinates

$$\begin{cases} r^l \\ r^{-l-1} \end{cases} P_l^m(\cos\theta) \begin{cases} \sin m\phi \\ \cos m\phi \end{cases}$$

Since we want a solution inside the sphere, we select the r^l solution for r since we do not want the solution to go to ∞ as $r \rightarrow 0$

Also, since the solution is independent of the ϕ , we do not want solution with ϕ , hence set $m = 0$, hence the basic solution is

$$V = r^l P_l(\cos\theta)$$

Since the general solution is a sum of these solutions, we get

$$V = \sum_l c_l r^l P_l(\cos\theta)$$

Now add a solution to Laplace solution so that the potential is zero at the surface, this is V_q as shown in the example on page 575:

$$V_q = \frac{q}{\sqrt{r^2 - 2ar\cos\theta + a^2}}$$

hence the general solution now becomes

$$\begin{aligned} V &= V_q + \sum_l c_l r^l P_l(\cos \theta) \\ &= \frac{q}{\sqrt{r^2 - 2ar \cos \theta + a^2}} + \sum_l c_l r^l P_l(\cos \theta) \end{aligned} \quad (1)$$

Now, boundary condition is $V = 0$ at $r = R$ so from (1)

$$\begin{aligned} 0 &= V_q + \sum_l c_l R^l P_l(\cos \theta) \\ &= \frac{q}{\sqrt{R^2 - 2aR \cos \theta + a^2}} + \sum_l c_l R^l P_l(\cos \theta) \end{aligned} \quad (2)$$

As per example, $\frac{q}{\sqrt{R^2 - 2aR \cos \theta + a^2}} = q \sum_l \frac{R^l P_l(\cos \theta)}{a^{l+1}}$

Hence (2) becomes

$$\begin{aligned} 0 &= q \sum_l \frac{R^l P_l(\cos \theta)}{a^{l+1}} + \sum_l c_l R^l P_l(\cos \theta) \\ -q \sum_l \frac{R^l P_l(\cos \theta)}{a^{l+1}} &= \sum_l c_l R^l P_l(\cos \theta) \end{aligned}$$

Compare coefficients, we see that

$$c_l R^l = -q \frac{R^l}{a^{l+1}} \rightarrow c_l = -q \frac{1}{a^{l+1}}$$

Hence (1) becomes

$$V = \frac{q}{\sqrt{r^2 - 2ar \cos \theta + a^2}} - q \sum_l \frac{r^l}{a^{l+1}} P_l(\cos \theta)$$

Now we sum the series solution. Need to convert the series into form shown in 5.2:

$\Phi(x, h) = \sum_l h^l P_l(x)$ then we can replace the sum with $(1 - 2xh + h^2)^{-\frac{1}{2}}$

So we need to have $\frac{1}{a} \left(\frac{r}{a}\right)^l = h^l$ hence

$$(1 - 2xh + h^2)^{-\frac{1}{2}} = \left(1 - 2x\left(\frac{r}{a^2}\right) + \left(\frac{r^2}{a^3}\right)\right)^{-\frac{1}{2}}$$

Then the series solution sums to be

$$V = \frac{q}{\sqrt{r^2 - 2ar \cos \theta + a^2}} - \frac{q}{\sqrt{\left(1 - 2 \cos \theta \left(\frac{r}{a^2}\right) + \left(\frac{r^2}{a^3}\right)\right)}}$$

The second term above is the potential of a charge $-q$ at a point $\left(0, 0, \frac{1}{a}\right)$, thus we could replace the grounded sphere by this charge and get the same potential for $r > R$ this is called the method of images, per book, page 576 discussion.

4.11 HW 11

Local contents

4.11.1	chapter 16, problem 1.1 Mary Boas, second edition	284
4.11.2	chapter 16, problem 1.2 Mary Boas, second edition	284
4.11.3	chapter 16, problem 1.3, Mary Boas, second edition	284
4.11.4	chapter 16, problem 1.4, Mary Boas, second edition	285
4.11.5	chapter 16, problem 1.5, Mary Boas, second edition	286
4.11.6	chapter 16, problem 1.8, Mary Boas , second edition	287
4.11.7	chapter 16, problem 1.10, Mary Boas, second edition	287
4.11.8	chapter 16, problem 2.12, Mary Boas, second edition	289
4.11.9	chapter 16, problem 2.13, Mary Boas, second edition	290
4.11.10	chapter 16, problem 2.14, Mary Boas, second edition	291
4.11.11	chapter 16, problem 2.15, Mary Boas, second edition	292
4.11.12	chapter 16, problem 2.17, Mary Boas, second edition	295

4.11.1 chapter 16, problem 1.1 Mary Boas, second edition

Find the probability that a single throw of die will give a number less than 3; an even number; a 6.

Solution

Sample space $S = \{1, 2, 3, 4, 5, 6\}$, hence $n_s = 6$

Let A the event that a number is less than 3

$$\text{Hence } \Pr(A) = \frac{n_A}{n_s} = \frac{2}{6} = \frac{1}{3}$$

Let B the event that a number is even

$$\text{Hence } \Pr(B) = \frac{n_B}{n_s} = \frac{3}{6} = \frac{1}{2}$$

Let C the event that a number is 6

$$\text{Hence } \Pr(C) = \frac{n_c}{n_s} = \frac{1}{6}$$

4.11.2 chapter 16, problem 1.2 Mary Boas, second edition

3 coins are tossed; what is the probability that 2 are heads and one is tail? that the first 2 are heads and the third tail? if at least 2 are heads, what is the probability that all are heads?

Solution

Sample space $S = \{hhh, hht, hth, htt, thh, tht, tth, ttt\}$, hence $n_s = 8$

Let A the event that 2 are heads and one is tail

$$\text{Hence } \Pr(A) = \frac{n_A}{n_s} = \frac{3}{8}$$

Let B the event that the first 2 are heads and the third tail

$$\text{Hence } \Pr(B) = \frac{n_B}{n_s} = \frac{1}{8}$$

For the third case, since at least 2 are heads, hence our sample space now is different, it is a subset of the original sample space and is the following: $S_1 = \{hhh, hht, hth, thh\}$, and $n_{S_1}=4$

Let C the event that all are heads out of the above same space S_1

$$\text{Hence } \Pr(C) = \frac{n_C}{n_{S_1}} = \frac{1}{4}$$

4.11.3 chapter 16, problem 1.3, Mary Boas, second edition

In a box there are 2 whites, 3 blacks and 4 red balls. If a ball is drawn at random, what is the probability that it is black? that it is not red?

Solution

Sample space $S = \{W, W, B, B, B, R, R, R, R\}$, hence $n_s = 9$

Let A be the event that ball thrown is black

Hence

$$\Pr(A) = \frac{n_A}{n_S} = \frac{3}{9}$$

Let B the event that it is not red Hence $\Pr(B) = 1 - \Pr(C)$ Where C is the event that ball drawn is red. Hence

$$\Pr(B) = 1 - \frac{n_C}{n_S} = 1 - \frac{4}{9} = \frac{5}{9}$$

4.11.4 chapter 16, problem 1.4, Mary Boas, second edition

A single card is drawn at random from a shuffled deck. What is the probability that it is red? that it is the ace of hearts? that it is either a 3 or a 5? that it is either an ace or red or both?

Solution

Sample space $S = \{\dots\}$ the 52 cards, hence $n_s = 52$

For first part, let A be the event that card is red, Hence

$$\Pr(A) = \frac{n_A}{n_S} = \frac{26}{52}$$

For second part, let A the event that it is the ace of hearts Hence,

$$\Pr(A) = \frac{n_A}{n_S} = \frac{1}{52}$$

For third part, let A be the event it is a 5, and let B be the event it is a 3. Hence

$$\Pr(A \cup B) = \Pr(A) + \Pr(B) - \Pr(A \cap B)$$

But $\Pr(A \cap B) = 0$ since events are mutually exclusive. Hence

$$\Pr(A \cup B) = \frac{n_A}{n_S} + \frac{n_B}{n_S} = \frac{4}{52} + \frac{4}{52} = \frac{8}{52}$$

For last part, let A event that it is an Ace. Let B event that it is a red. Hence

$$\begin{aligned}
 \Pr(A \cup B) &= \Pr(A) + \Pr(B) - \Pr(A \cap B) \\
 &= \frac{4}{52} + \frac{13}{52} - \frac{1}{52} \\
 &= \frac{16}{52}
 \end{aligned}$$

In the above, $\Pr(A \cap B) = \frac{1}{52}$ since there is only one card that is both an Ace and a red.

4.11.5 chapter 16, problem 1.5, Mary Boas, second edition

Given a family of 2 children, what is the probability that both are boys? that at least one is girl? Given that at least one is girl, what is the probability that both are girls? Given that the first 2 are girls, what is the probability that an expected 3rd child will be a boy? (assume boys and girls are equally likely).

Solution

What is the probability that both are boys?

Let A be event that both are boys. The family could have had a boy followed by a girl or a boy followed by a boy or a girl followed by a boy or a girl followed by a girl. Hence the sample space $S = \{BG, BB, GB, GG\}$ hence $n_s = 4$

$$\text{So } \Pr(A) = \frac{n_A}{n_s} = \frac{1}{4}$$

At least one is girl?

$$\text{Let } A \text{ be event that at least one is girl So } \Pr(A) = \frac{n_A}{n_s} = \frac{3}{4}$$

Given that at least one is girl, what is the probability that both are girls?

Since we are given that at least one is girl, then the sample space now is

$$S = \{BG, GB, GG\}$$

hence $n_s = 3$

$$\text{Let } A \text{ event that both are girls. So } \Pr(A) = \frac{n_A}{n_s} = \frac{1}{3}$$

Given that the first 2 are girls, what is the probability. that an expected 3rd child will be a boy?

Since the event of having a new child is independent of gender of previous children, the expected 3rd child being a boy is $\frac{1}{2}$ regardless of what gender or number of children already born. (This is like tossing a coin, getting a head will have Probability of 50% regardless of the history of tosses.).

4.11.6 chapter 16, problem 1.8, Mary Boas , second edition

An integer N is chosen at random with $1 \leq N \leq 100$. What is the probability that N is divisible by 11? That $N > 90$? That $N \leq 3$? That N is a perfect square?

Solution

What is the probability. that N is divisible by 11?

Let A be event that N is divisible by 11. Sample space $S = \{1, 2, \dots, 100\}$ hence $n_s = 100$

Numbers that are divisible by 11 are 11, 22, 33, 44, 55, 66, 77, 88, 99 so $n_A = 9$. So $\Pr(A) = \frac{n_A}{n_s} = \frac{9}{100}$

That $N > 90$?

Let A be event that $N > 90$. Numbers that are > 90 are 91, 92, 93, 94, 95, 96, 97, 98, 99, 100 so $n_A = 10$ So $\Pr(A) = \frac{n_A}{n_s} = \frac{10}{100} = \frac{1}{10}$

That $N \leq 3$? Let A be event that $N \leq 3$

Numbers that $N \leq 3$ are 1, 2, 3 so $n_A = 3$. So $\Pr(A) = \frac{n_A}{n_s} = \frac{3}{100}$

That N is a perfect number? Let A be event that N is perfect square.

Numbers that are perfect squares are 1, 4, 9, 16, 25, 36, 49, 64, 81, 100

$\Pr(A) = \frac{n_A}{n_s} = \frac{10}{100} = \frac{1}{10}$

4.11.7 chapter 16, problem 1.10, Mary Boas, second edition

A shopping mall has 4 entrances, one in North, one in south, and 2 on the east. If you enter at random, shop and then exit at random, what is the probability that you enter and exist on the same side of the mall?

Solution

Let N_x represent the event of entering using entrance x where x is north, south, or east.

So, N_n the event of entering from the north entrance, N_s means enter from the south entrance, N_{e1} means enter from the first entrance on the east side, and N_{e2} means enter from the second entrance on the east side.

Let

Hence here $S = \{N_n, N_s, N_{e1}, N_{e2}\}$, $n_s = 4$

Then $n_e = 2$ (since there are 2 doors on the east side, and each is equally likely to use to enter).

Hence, $\Pr(N_{e1} \cup N_{e2}) =$ Probability of entering from the east side is $\frac{n_e}{n_s} = \frac{2}{4} = \frac{1}{2}$

Hence, $\Pr(N_n) = \text{Probability of entering from the north side} = \frac{1}{n_s} = \frac{1}{4}$

Hence, $\Pr(N_s) = \text{Probability of entering from the south side} = \frac{1}{n_s} = \frac{1}{4}$.

Similarly let E_x represent the event of leaving the mall using exist x

Hence here $S = \{E_n, E_s, E_{e1}, E_{e2}\}$, $n_s = 4$

Then $n_e = 2$ (since there are 2 doors on the east side, and each is equally likely to use to leave).

Hence, $\Pr(E_{e1} \cup E_{e2}) = \text{Probability of leaving from the east side} = \frac{2}{4} = \frac{1}{2}$

Hence, $\Pr(E_n) = \text{Probability of leaving from the north side} = \frac{1}{4}$

Hence, $\Pr(E_s) = \text{Probability of leaving from the south side} = \frac{1}{4}$

Let X be the event of entering and exiting from the same side. So this is the probability of leaving from the east side given that we entered from the east side, or leaving from the north side given we entered from the north side, or leaving from the south side given we entered from the south side. Using conditional probability, Hence we write:

$$\begin{aligned} \Pr(X) &= \Pr([(E_{e1} \cup E_{e2}) | (N_{e1} \cup N_{e2})] \cup (E_n | N_n) \cup (E_s | N_s)) \\ &= \Pr((E_{e1} \cup E_{e2}) | (N_{e1} \cup N_{e2})) + \Pr(E_n | N_n) + \Pr(E_s | N_s) \end{aligned} \quad (1)$$

But

$$\begin{aligned} \Pr((E_{e1} \cup E_{e2}) | (N_{e1} \cup N_{e2})) &= \Pr(E_{e1} \cup E_{e2}) \times \Pr(N_{e1} \cup N_{e2}) \\ &= \frac{1}{2} \times \frac{1}{2} = \frac{1}{4} \end{aligned}$$

And

$$\begin{aligned} \Pr(E_n | N_n) &= \Pr(E_n) \times \Pr(N_n) \\ &= \frac{1}{4} \times \frac{1}{4} \\ &= \frac{1}{16} \end{aligned}$$

And

$$\begin{aligned}
 \Pr(E_s|N_s) &= \Pr(E_s) \times \Pr(N_s) \\
 &= \frac{1}{4} \times \frac{1}{4} \\
 &= \frac{1}{16}
 \end{aligned}$$

Hence (1) becomes

$$\begin{aligned}
 \Pr(X) &= \Pr((E_{e1} \cup E_{e2})|(N_{e1} \cup N_{e2})) + \Pr(E_n|N_n) + \Pr(E_s|N_s) \\
 &= \frac{1}{4} + \frac{1}{16} + \frac{1}{16} \\
 &= \frac{3}{8}
 \end{aligned}$$

There is a much faster method to solve this.

Label each entrance as N, S, E_1, E_2 . Set up the sample space (all possible events) as $S = \{NN, NS, NE_1, NE_2, SN, SS, SE_1, SE_2, E_1E_1, E_1E_2, E_1S, E_1N, E_2E_1, E_2E_2, E_2S, E_2N, \}$

Where the first letter is the entrance, and the second letter is the exit.

By counting we count all those with BOTH E as the first letter and the second letter. We see there are 6 of these, and number of possible events is 16, hence the answer is $\frac{3}{8}$ as above

4.11.8 chapter 16, problem 2.12, Mary Boas, second edition

Use sample space of example 1 to answer the following questions.

Solution

Sample space of example 1 is

$$S = \{hhh, hth, ttt, tht, hht, thh, tth, htt\}$$

(a) If there are more heads than tails, what is the probability of one tail?

The sample space here is

$$S = \{hhh, \overline{hth}, \overline{hht}, \overline{thh}\}$$

$n_s = 4$. So from this sample space, $\Pr(\text{one tail}) = \frac{3}{4}$

(b) If two heads did not appear in succession, what is the probability of all tails?

The sample space here is

$$S = \{hth, \overline{ttt}, tht, tth, htt\}$$

$n_s = 5$. So from this sample space, $\Pr(\text{all tails}) = \frac{1}{5}$

(c) if the coins did not all fall alike, what is the probability that 2 succession were alike?

$$S = \{hth, tht, \widehat{hht}, \widehat{thh}, \widehat{tth}, \widehat{htt}\}$$

$n_s = 5$ So from this sample space,

$$\Pr(2 \text{ succession were alike}) = \frac{4}{6} = \frac{2}{3}$$

(d) if N_t =number of tails, N_h =number of heads, what is the probability. that $|N_h - N_t| = 1$?

From $S = \{hhh, hth, ttt, tht, hht, thh, tth, htt\}$, we see that $|N_h - N_t|$ for each sample point is

$$\{3, 1, 3, 1, 1, 1, 1, 1\}$$

$n_s = 8$. Hence $\Pr(|N_h - N_t| = 1) = \frac{6}{8} = \frac{3}{4}$

(e) If there is at least one head, what is the probability. of exactly two heads?

Since we are told there is at least one head, then we remove the sample points that has no head in them, then our new sample space is

$$S = \{hhh, \widehat{hth}, tht, \widehat{hht}, \widehat{thh}, tth, htt\}, n_s = 7$$

So $\Pr(\text{exactly two heads}) = \frac{3}{7}$

4.11.9 chapter 16, problem 2.13, Mary Boas, second edition

A student claims in problem 1.5 that if one child is a girl, the probability that both are girls is $\frac{1}{2}$. Use appropriate sample spaces to show what is wrong with the following argument: It does not matter whether the girl is the older child or the younger; in either case the probability is $\frac{1}{2}$ that the other child is a girl.

This is problem 1.5 for reference:

Given a family of 2 children, what is the probability that both are boys? that at least one is girl? Given that at least one is girl, what is the probability that both are girls? Given that the first 2 are girls, what is the probability. that an expected 3rd child will be a boy? (assume boys and girls are equally likely).

Solution

Need to distinguish between the older and the younger child.

Let a subscript o means older child, and subscript y means younger child.

Then the sample space is written as

$$S = \{B_oB_y, B_oG_y, G_oB_y, G_oG_y\}$$

Here we see that if one child is a girl, then the probability that the other child is a girl is taken from this sample space $S = \{B_oG_y, G_oB_y, G_oG_y\}$ which is then $\frac{1}{3}$ and not $\frac{1}{2}$

If the **older child is a girl** G_o , then the sample space is $S = \{G_oB_y, G_oG_y\}$, and from this the probability that the other child is a girl is $\frac{1}{2}$

If the **younger child is a girl** G_y , then the sample space is $S = \{B_oG_y, G_oG_y\}$, and from this the probability that the other child is a girl is $\frac{1}{2}$

We see that the student is wrong, since we do get a different probability for the other child being a girl if we know that the first child is the older or the younger girl compared to if we know only that the first child is a girl. The reason this happens is because in each case we have different sample space to use.

4.11.10 chapter 16, problem 2.14, Mary Boas, second edition

Problem

2 dice are thrown, use the sample space in 2.4 to answer the following questions.

Solution

Sample space 2.4 is

1,1 1,2 1,3 1,4 1,5 1,6
 2,1 2,2 2,3 2,4 2,5 2,6
 3,1 3,2 3,3 3,4 3,5 3,6
 4,1 4,2 4,3 4,4 4,5 4,6
 5,1 5,2 5,3 5,4 5,5 5,6
 6,1 6,2 6,3 6,4 6,5 6,6

Here $n_s = 36$.

The entry in the above same space shows the number from the first die throw, followed by the number from the second die throw.

(a) What is the probability of being able to form a 2 digit number greater than 33 with the 2 numbers of the dice?

Looking at the sample space above, we see that these numbers in bold are all greater than 33:

1,1	1,2	1,3	1,4	1,5	1,6
2,1	2,2	2,3	2,4	2,5	2,6
3,1	3,2	3,3	3,4	3,5	3,6
4,1	4,2	4,3	4,4	4,5	4,6
5,1	5,2	5,3	5,4	5,5	5,6
6,1	6,2	6,3	6,4	6,5	6,6

Hence the Probability is $\frac{27}{36} = \frac{3}{4}$

(b) Repeat part (a) for the probability. of being able to form a 2 digit number greater than or equal to 42.

1,1	1,2	1,3	1,4	1,5	1,6
2,1	2,2	2,3	2,4	2,5	2,6
3,1	3,2	3,3	3,4	3,5	3,6
4,1	4,2	4,3	4,4	4,5	4,6
5,1	5,2	5,3	5,4	5,5	5,6
6,1	6,2	6,3	6,4	6,5	6,6

Here the numbers in bold meet the condition. So Probability is $\frac{25}{36}$

(c) Can you find a 2 digit number (or numbers) such that the probability. of being able to form a larger number is the same as the probability. of being able to form a small number?

Let me write all the numbers that can occur in sequence.

11,12,13,14,15,16,21,22,23,24,25,26,31,32,33,34,35,36,41,42,43,44,45,46,51,52,53,
54,55,56,61,62,63,64,65,66

Since there are 36 numbers, we want to find the middle of the above sequence such that there are as many numbers above as below.

We see that the numbers after the 18th indexed number and before the 19th indexed number will meet this criteria. The 18th number is 36 and the 19th number is 40.

Hence the numbers with the probability that to form a larger number is the same as the probability. of being able to form a small number are

37,38,39,40

4.11.11 chapter 16, problem 2.15, Mary Boas, second edition

Use sample space in 2.4 and sample space 2.5 to answer the following questions about a toss of 2 dice.

Solution

Sample space 2.4 is

1,1 1,2 1,3 1,4 1,5 1,6
 2,1 2,2 2,3 2,4 2,5 2,6
 3,1 3,2 3,3 3,4 3,5 3,6
 4,1 4,2 4,3 4,4 4,5 4,6
 5,1 5,2 5,3 5,4 5,5 5,6
 6,1 6,2 6,3 6,4 6,5 6,6

Here $n_s = 36$.

Sample space 2.5 is

sum	2	3	4	5	6	7	8	9	10	11	12
Probability	$\frac{1}{36}$	$\frac{2}{36}$	$\frac{3}{36}$	$\frac{4}{36}$	$\frac{5}{36}$	$\frac{6}{36}$	$\frac{5}{36}$	$\frac{4}{36}$	$\frac{3}{36}$	$\frac{2}{36}$	$\frac{1}{36}$

Sum means the sum of one die throw and the second die throw. So Max sum 12 means $6 + 6$, etc...

(a) What is the probability. that the sum is ≤ 4 ?

Here the probability. is $\frac{1}{36} + \frac{2}{36} + \frac{3}{36} = \frac{6}{36} = \frac{1}{6}$

(b) What is the probability. that the sum is even.

These are the sample points $\{2, 4, 6, 8, 10, 12\}$

Here the probability. is the sum of the probability of each of these sample points, which is

$$\frac{1}{36} + \frac{3}{36} + \frac{5}{36} + \frac{5}{36} + \frac{3}{36} + \frac{1}{36} = \frac{18}{36} = \frac{1}{2}$$

To verify, I can use the 2.4 sample space to mark those points which sum to even number

1,1 1,2 1,3 1,4 1,5 1,6
 2,1 2,2 2,3 2,4 2,5 2,6
 3,1 3,2 3,3 3,4 3,5 3,6
 4,1 4,2 4,3 4,4 4,5 4,6
 5,1 5,2 5,3 5,4 5,5 5,6
 6,1 6,2 6,3 6,4 6,5 6,6

We see that these are half the points. Which agrees with the above.

(c) What is the probability. that the sum is divisible by 3?

The sums that are divisible by 3 are: {3, 6, 9, 12}

Here the probability. is the sum of the probability of each of these sample points, which is

$$\frac{2}{36} + \frac{5}{36} + \frac{4}{36} + \frac{1}{36} = \frac{12}{36} = \frac{1}{3}$$

(d) If the sum is odd, what is the probability. that it is equal to 7?

Here the sample space is {3, 5, 7, 9, 11}

Since here the events are not equally likely, *I can not say* that probability of it being a 7 is $\frac{1}{5}$, instead, the probability. is given by

$$\begin{aligned} &= \frac{\Pr(7)}{\Pr(3) + \Pr(5) + \Pr(7) + \Pr(9) + \Pr(11)} \\ &= \frac{\frac{6}{36}}{\frac{2}{36} + \frac{4}{36} + \frac{6}{36} + \frac{4}{36} + \frac{2}{36}} \\ &= \frac{6}{2 + 4 + 6 + 4 + 2} \\ &= \frac{6}{18} \\ &= \frac{1}{3} \end{aligned}$$

(e) What is the probability that the product of the numbers on the 2 dice is 12?

Using sample space 2.4, the numbers marked in *italic* have product that is 12

1,1	1,2	1,3	1,4	1,5	1,6
2,1	2,2	2,3	2,4	2,5	2,6
3,1	3,2	3,3	3,4	3,5	3,6
4,1	4,2	4,3	4,4	4,5	4,6
5,1	5,2	5,3	5,4	5,5	5,6
6,1	6,2	6,3	6,4	6,5	6,6

So there are 4 tosses that can result in number whose product is 12. Hence the probability is $\frac{4}{36} = \frac{1}{9}$

4.11.12 chapter 16, problem 2.17, Mary Boas, second edition

Two dice are thrown. Given the information that the number on the first die is even and the number on the second is < 4 , set up an appropriate sample space and answer the following questions

Solution

Sample space is $S = \{(2,1), (2,2), (2,3), (4,1), (4,2), (4,3), (6,1), (6,2), (6,3)\}$

Where in (a,b) , a , is the first die number (which must be even), and b is the second die number (which must be < 4). hence $n_s = 9$, i.e. 9 sample points.

(a) what are the probable sums and their probabilities?

Possible sums are (1:1) corresponding with the sample space above :

$$Sum = \{3, 4, 5, 5, 6, 7, 7, 8, 9\}$$

$$\text{Hence } \Pr(3) = \frac{1}{9}; \Pr(4) = \frac{1}{9}; \Pr(5) = \frac{2}{9}; \Pr(6) = \frac{1}{9}; \Pr(7) = \frac{2}{9}; \Pr(8) = \frac{1}{9}; \Pr(9) = \frac{1}{9}$$

(b) What are the most probable sums?

From above we see it is 5 and 7

(c) What is the probability that the sum is even?

From the sum sample space $Sum = \{3, \widehat{4}, 5, 5, \widehat{6}, 7, 7, \widehat{8}, 9\}$ we see that the probability of the sum is even $= \frac{3}{9} = \frac{1}{3}$

4.12 HW 12

Local contents

4.12.1	chapter 16, problem 3.3, Mary Boas, second edition	297
4.12.2	chapter 16, problem 3.5, Mary Boas, second edition	297
4.12.3	chapter 16, problem 3.10, Mary Boas, second edition	298
4.12.4	chapter 16, problem 3.14, Mary Boas, second edition	300
4.12.5	chapter 16, problem 3.15, Mary Boas, second edition	302
4.12.6	chapter 16, problem 3.16, Mary Boas, second edition	305
4.12.7	chapter 16, problem 3.17, Mary Boas , second edition	306
4.12.8	chapter 16, problem 3.19, Mary Boas , second edition	310
4.12.9	chapter 16, problem 3.21, Mary Boas , second edition	311
4.12.10	chapter 16, problem 4.1, Mary Boas , second edition	312
4.12.11	chapter 16, problem 4.4, Mary Boas , second edition	313
4.12.12	chapter 16, problem 4.5, Mary Boas , second edition	315
4.12.13	chapter 16, problem 4.7, Mary Boas , second edition	316
4.12.14	chapter 16, problem 4.8, Mary Boas , second edition	317
4.12.15	chapter 16, problem 4.10, Mary Boas , second edition	320
4.12.16	chapter 16, problem 4.11 , Mary Boas , second edition	322
4.12.17	chapter 16, problem 4.15 , Mary Boas , second edition	325
4.12.18	chapter 16, problem 4.17 , Mary Boas , second edition	325
4.12.19	chapter 16, problem 4.21 , Mary Boas , second edition	326

4.12.1 chapter 16, problem 3.3, Mary Boas, second edition

What is the probability of getting the sequence $hhhttt$ in six tosses of a coin? If you know the first 3 are heads, what is the probability that the last 3 are tails? If you do not know anything about the first three, what is the probability. that the last three are tails?

Solution

First part: Looking at the sequence pattern we can get out of a six tosses of a coin, we see that there are a total of 2^6 different sequences (since there are 2 choices at each position, and there are 6 positions), this and the fact that each output of a toss of a coin is independent of the output of the previous toss, means the chance of any one specific sequence is the same as any other. Hence the chance of getting $hhhttt$ will be $\frac{1}{2^6} = \frac{1}{64}$

Second part: Now, if we know the first 3 are heads, we can solve this in 2 ways.

The first way: Since the first 3 positions are now known, then the total number of different sequences we have to look at is reduced from 2^6 to 2^3 , hence the chance of getting a ttt is $\frac{1}{2^3} = \frac{1}{8}$

The second way: Let A be the event of getting 3 heads in the first 3 tosses. Let B be the event of getting 3 tails in the last 3 tosses. Hence we want to find $P_A(B)$

But since A and B are independent events, $P_A(B) = P(B)$

So $P_A(B) = P(B) = \frac{1}{2^3} = \frac{1}{8}$

Last part, here we do not know anything about the first 3 tosses. So the first 3 positions in the sequence of length 6 are unknown. Only the last 3 positions of the sequence are known which are ttt . This means again that there is a chance of $\frac{1}{2^3} = \frac{1}{8}$ that the last 3 are ttt

4.12.2 chapter 16, problem 3.5, Mary Boas, second edition

What is the probability that a number $n, 1 \leq n \leq 99$ is divisible by both 6 and 10? By either 6 or 10 or both?

Solution

Let A=event that a number is divisible by 6. Hence $P(A) = \frac{16}{99}$ since there are 16 numbers between 1 and 99 that are divisible by 6.

Let B=event that a number is divisible by 10. Hence $P(B) = \frac{9}{99}$ since there are 9 numbers between 1 and 99 that are divisible by 10.

First part: We want $P(AB)$ since these 2 events are dependent on each others, then

$$P(AB) = P(A) P_A(B)$$

Now to find $P_A(B)$, this is the event a number is divisible by 10 given it is divisible by 6. There are 3 numbers divisible by 10 out of the 16 numbers that are divisible by 6, and they are 30, 60, 90. Hence $P_A(B) = \frac{3}{16}$

So

$$P(AB) = P(A) P_A(B) = \left(\frac{16}{99}\right)\left(\frac{3}{16}\right) = \frac{3}{99} = \frac{1}{33}$$

For the second part:

Here we want to find

$$\begin{aligned} P(A \cup B) &= P(A) + P(B) - P(AB) \\ &= \left(\frac{16}{99}\right) + \left(\frac{9}{99}\right) - \left(\frac{1}{33}\right) \\ &= \frac{2}{9} \end{aligned}$$

4.12.3 chapter 16, problem 3.10, Mary Boas, second edition

3 letters and their envelopes are piled on a desk. If someone puts the letters in the envelopes at random, what is the probability that each letter gets into its own envelop?

Solution

(a) Set up the sample space. Let envelopes be A,B,C, let letters be a,b,c.

Each sample point is one row in the following table.

A	B	C
a	b	c
a	c	b
b	a	c
b	c	a
c	a	b
c	b	a

From this table, we see that the probability that each letter gets into its own envelop is $\frac{1}{6}$, which means one row above meets this condition out of 6 rows. (The first row)

Another way to solve this: There is $\frac{1}{3}$ chance of a letter getting into the correct envelop. This leaves 2 letters and 2 envelopes, now we have a chance of $\frac{1}{2}$ of one of the 2 remaining

letters going into one of the 2 remaining envelopes. After this, we have one letter and one envelope, which have a 1 chance of getting into the right envelop. Hence the total probability is $\frac{1}{3} \times \frac{1}{2} \times 1 = \frac{1}{6}$ the same as stated above.

(b) What is the probability that at least one letter gets into its own envelope?

From looking at the table we see that this probability is $\frac{4}{6}$

This could be solved using probability calculus as well like this: Let n be the number of envelopes or letters. Then the probability P of of all letters going to the wrong envelopes will be

$$\begin{aligned}
 P &= 1 - \left[n \frac{(n-1)!}{n!} - \binom{n}{2} \frac{(n-2)!}{n!} + \binom{n}{3} \frac{(n-3)!}{n!} \right] \\
 &= 1 - \left[3 \frac{(3-1)!}{3!} - \binom{3}{2} \frac{(3-2)!}{3!} + \binom{3}{3} \frac{(3-3)!}{3!} \right] \\
 &= 1 - \left[3 \times \frac{2}{6} - \frac{6}{2 \cdot 6} + \frac{1}{6} \right] \\
 &= 1 - \left[1 - \frac{1}{2} + \frac{1}{6} \right] \\
 &= 1 - \left[\frac{4}{6} \right] \\
 &= \frac{2}{6}
 \end{aligned}$$

Hence the probability of at least one letter going to the correct envelop is $1 - P = 1 - \frac{2}{6} = \frac{4}{6}$ which agrees with the answer above obtained by direct counting from the table.

(c) Let A mean that a got into envelop A and so on. Find the probability $P(A)$ (i.e. that a got into A .) Find $P(B)$ and $P(C)$. Find $P(A + B)$ (means a or b got into correct envelopes). Find $P(AB)$ (meaning both a and b got into correct envelopes. Verify equation 3.6

Since there are envelopes, then $P(A) = \frac{1}{3}$

Similarly for $P(B)$ and $P(C)$

Now, $P(A + B) = \frac{1}{2}$ by looking at table above, we see that rows 1, 2 and 6 meet this criteria. so 3 sample points out of 6.

To find $P(AB)$: There are $n!$ ways to arrange n envelopes, and there are $(n-2)!$ ways to arrange the remaining letters (after 2 letters got into the correct envelopes). Hence the chance of 2 letters getting into the correct envelopes is $\frac{(n-2)!}{n!} = \frac{(3-2)!}{3!} = \frac{1}{6}$

from table, this is verified by seeing that only one row out of 6 meets this condition. Hence $P(AB) = \frac{1}{6}$

To verify 3.6 which says $P(A + B) = P(A) + P(B) - P(AB)$, then substitute values found, we get for LHS $\frac{1}{2}$, and for RHS we get $\frac{1}{3} + \frac{1}{3} - \frac{1}{6} = \frac{1}{2}$, hence equation verified.

4.12.4 chapter 16, problem 3.14, Mary Boas, second edition

A player succeeds in making a basket 3 tries out of 4. How many tries are needed to have a probability of larger than 0.99 of at least one basket?

Solution

Let P be the probability of scoring at each try (in this example, $P = \frac{3}{4}$).

Let E_1 =event of scoring in the first try.

Let E_2 =event of scoring in the second try.

To make notations shorts, let me call P_n as the probability of even E_n occurring.

Hence $P(E_1)$ will be written as P_1

So chance of scoring after 2 tries =

$$\begin{aligned} P(E_1 + E_2) &= P(E_1) + P(E_2) - P(E_1E_2) \\ &= P_1 + P_2 - P(E_1E_2) \end{aligned} \quad (1)$$

But events E_1, E_2 here are independent of each others, hence $P(E_1E_2) = P(E_1)P(E_2) = P_1P_2$

So (1), the chance of scoring after 2 tries, can now be written as:

$$P(E_1 + E_2) = P_1 + P_2 - P_1P_2 \quad (2)$$

Similarly, the chance of scoring after 3 tries is

$$\begin{aligned} P((E_1 + E_2) + E_3) &= P(E_1 + E_2) + P(E_3) - P((E_1 + E_2)E_3) \\ &= P(E_1 + E_2) + P(E_3) - P(E_1 + E_2) P(E_3) \end{aligned} \quad (3)$$

Substitute (2) into (3) we get

$$\begin{aligned}
P((E_1 + E_2) + E_3) &= P_1 + P_2 - P_1P_2 + P_3 - [(P_1 + P_2 - P_1P_2)P_3] \\
&= P_1 + P_2 - P_1P_2 + P_3 - [P_1P_3 + P_2P_3 - P_1P_2P_3] \\
&= P_1 + P_2 + P_3 - P_1P_2 - P_1P_3 - P_2P_3 + P_1P_2P_3 \\
&= P_1 + P_2 + P_3 - (P_1P_2 + P_1P_3 + P_2P_3) + P_1P_2P_3
\end{aligned}$$

Now since each P_i is the same, which is $\frac{3}{4}$ in this example, I can write the above as

$$\begin{aligned}
P((E_1 + E_2) + E_3) &= P_1 + P_2 + P_3 - (P_1P_2 + P_1P_3 + P_2P_3) + P_1P_2P_3 \\
&= P + P + P - (PP + PP + PP) + PPP \\
&= 3P - 3P^2 + P^3
\end{aligned}$$

The above is the probability of at least one score after 3 tries. We can continue this process, getting the probability of at least one score after 4 tries. This will result in the following formula.

$$P((E_1 + E_2 + E_3) + E_4) = 4P - 6P^2 + 4P^3 - P^4$$

So, the pattern is clear, in general, after n tries, the chance of at least one score is

$$nP - \binom{n}{2}P^2 + \binom{n}{3}P^3 - \binom{n}{4}P^4 + \dots + \binom{n}{n-1}P^{n-1} - P^n$$

Now I need to find n which will cause the above chance of getting a value larger than 0.99

So need to solve the above for $n = .99$ and then take the next n after that.

i.e. need to solve

$$nP - \binom{n}{2}P^2 + \binom{n}{3}P^3 - \binom{n}{4}P^4 + \dots + \binom{n}{n-1}P^{n-1} - P^n = .99$$

I do not know how to solve the above as is, so I'll just make trial and error.

Will try $n = 2$, for $n = 2$, the LHS of the above equation is

$$\begin{aligned}
2P - \binom{2}{2}P^2 &= 2 \times \frac{3}{4} - \left(\frac{3}{4}\right)^2 \\
&= 0.9375
\end{aligned}$$

This is still less than 0.99. So try for larger n , for $n = 3$

$$\begin{aligned} 3P - \binom{3}{2}P^2 + \binom{3}{3}P^3 &= 3\left(\frac{3}{4}\right) - 3\left(\frac{3}{4}\right)^2 + \left(\frac{3}{4}\right)^3 \\ &= 0.98438 \end{aligned}$$

This is still less than 0.99 so try for $n = 4$

$$\begin{aligned} 4P - \binom{4}{2}P^2 + \binom{4}{3}P^3 - \binom{4}{4}P^4 &= 4\left(\frac{3}{4}\right) - 6\left(\frac{3}{4}\right)^2 + 4\left(\frac{3}{4}\right)^3 - \left(\frac{3}{4}\right)^4 \\ &= 0.99609 \end{aligned}$$

This is larger than 0.99, hence the player needs to try 4 tries

Another way to solve the problem is

Let P be the probability of scoring at each try (in this example, $P = \frac{3}{4}$).

So probability of not scoring is $1 - P = \frac{1}{4}$

So probability of not scoring after n tries is $\left(\frac{1}{4}\right)^n$

So need to solve the equation

$$\begin{aligned} \left(\frac{1}{4}\right)^n &= .01 \\ n \log\left(\frac{1}{4}\right) &= \log(.01) \\ n &= \frac{\log(.01)}{\log(.25)} \\ &= 3.3219 \end{aligned}$$

Hence $n = 4$ (the next higher integer value).

4.12.5 chapter 16, problem 3.15, Mary Boas, second edition

Use Baye's formula 3.8 to repeat these simple problems previously done using reduced sample space method

- (a) In a family of children, what is the chance that both are girls if one is girl?
 (b) What is the chance of all heads in a 3 tosses of a coin if you know that at least one is head?

Solution

The sample space here is $\{gg, gb, bg, bb\}$

Let A=event that both are girls

Let B=event that at least one is a girl

- (a) We want to find $P_B(A)$

$$P_B(A) = \frac{P(AB)}{P(B)} \quad (1)$$

Now $P(B) = \frac{3}{4}$

To find $P(AB)$, I can not write $P(AB) = P(A)P(B)$ since here these 2 events are not independent. Here the probability of A implies B, hence $P(AB) = P(A) = \frac{1}{4}$

So substitute into (1)

$$\begin{aligned} P_B(A) &= \frac{\frac{1}{4}}{\frac{3}{4}} \\ &= \frac{1}{3} \end{aligned}$$

- (b) What is the chance of all heads in a 3 tosses of a coin if you know that at least one is head?

Let A=event of 3 heads.

Let B=event of at least one head.

$\{hhh, hth, hht, htt, thh, tht, tth, ttt\}$

$$P_B(A) = \frac{P(BA)}{P(B)} \quad (1)$$

But $P(B) = \frac{7}{8}$

But $P(BA)$ is the probability. of 3 heads and at least one head. So events are not independent. So $P(BA)$ is the same as $P(A)$ which is $\frac{1}{8}$

Substitute into (1) we get

$$\begin{aligned} P_B(A) &= \frac{\frac{1}{8}}{\frac{7}{8}} \\ &= \frac{1}{7} \end{aligned}$$

A long way to solve the above is

The sample space here is $\{gg, gb, bg, bb\}$

Let A=event that both are girls

Let B=event that at least one is a girl

(a) We want to find $P(A|B)$

$$P(A|B) = \frac{P(A) P(B|A)}{P(A) P(B|A) + P(\text{not } A) P(B|\text{not } A)} \quad (1)$$

Now $P(A) = \frac{1}{4} \rightarrow P(\text{not } A) = \frac{3}{4}$

$P(B|A) = 1$ since given both are girl, then there is a 100% chance that one is a girl.

$P(B|\text{not } A) = \frac{2}{3}$, since when not both are girls, the sample space is $\{gb, bg, bb\}$, and from this, there is 2 sample points with at least a girl, hence $\frac{2}{3}$

Substitute into (1) we get

$$\begin{aligned} P(A|B) &= \frac{\frac{1}{4} \times 1}{\frac{1}{4} \times 1 + \frac{3}{4} \times \frac{2}{3}} \\ &= \frac{\frac{1}{4}}{\frac{1}{4} + \frac{2}{4}} \\ &= \frac{\frac{1}{4}}{\frac{3}{4}} \\ &= \frac{1}{3} \end{aligned}$$

(b) What is the chance of all heads in 3 tosses of a coin if you know that at least one is head?

Let A = event of 3 heads.

Let B = event of at least one head.

$\{hhh, hth, hht, htt, thh, tht, tth, ttt\}$

$$P(A|B) = \frac{P(A) P(B|A)}{P(A) P(B|A) + P(\text{not } A) P(B|\text{not } A)} \quad (2)$$

$$\text{so } P(A) = \frac{1}{7} \rightarrow P(\text{not } A) = \frac{6}{7}$$

$$P(B|A) = 1$$

$$P(B|\text{not } A) = \frac{6}{7}$$

Substitute into (2) we get

$$\begin{aligned} P(A|B) &= \frac{\frac{1}{7} \times \frac{6}{7}}{\frac{1}{7} \times \frac{6}{7} + \frac{6}{7} \times \frac{6}{7}} \\ &= \frac{\frac{6}{49}}{\frac{6}{49} + \frac{36}{49}} \\ &= \frac{6}{42} \\ &= \frac{1}{7} \end{aligned}$$

4.12.6 chapter 16, problem 3.16, Mary Boas, second edition

Suppose you have 3 nickels and 4 dimes in your right pocket and 2 nickels and a quarter in your left pocket. You pick a pocket at random and from it select a coin at random. If it is a nickel, what is the probability it came from the right pocket?

Solution

Use Bayes' formula.

Let A = event that the coin picked is a nickel.

Let B = event that the pocket selected was the right pocket.

We want to find

$$P_A(B) = \frac{P(BA)}{P(A)} \quad (1)$$

So need to find $P(A)$ and $P(BA)$

$P(A)$ is the probability of picking a nickel. But there are 2 pockets, so this probability is the probability of picking the nickel from the left pocket or the probability of picking the nickel from the right pocket.

Now the probability. of picking a nickel from the left pocket is the probability. of picking the left pocket and then picking a nickel from the left pocket. This is $\frac{1}{2} \times \frac{2}{3}$

Similarly, the probability. of picking a nickel from the right pocket is the probability. of picking the right pocket and then picking a nickel from the right pocket. This is $\frac{1}{2} \times \frac{3}{7}$

$$\text{Hence } P(A) = \left(\frac{1}{2} \times \frac{2}{3}\right) + \left(\frac{1}{2} \times \frac{3}{7}\right) = \frac{23}{42}$$

Now, need to find $P(BA)$ which is the probability of picking the right pocket and then a nickel was selected from the right pocket in this case. This is $\frac{1}{2} \times \frac{3}{7} = \frac{3}{14}$

Substitute these values in (1) we get

$$\begin{aligned} P_A(B) &= \frac{P(BA)}{P(A)} \\ &= \frac{\frac{3}{14}}{\frac{23}{42}} \\ &= \frac{9}{23} \end{aligned}$$

4.12.7 chapter 16, problem 3.17, Mary Boas , second edition

(a) There are 3 red and 5 black balls in one box and 6 red and 4 white balls in another. If you pick a box at random, and then pick a ball from it at random, what is the probability it is red? black? white? That it is either a red or a white?

Solution

Let E=Event of selecting the first box (one with 3 red and 5 black balls)

Let M=Event of selecting the second box.

Let R=Event of selecting a red ball.

Let B=Event of selecting a black ball.

Let W=Event of selecting a white ball.

(a) The probability of picking a red is the probability of picking the A box and then the probability selecting a red ball from it, OR the probability of picking the B box and then the probability of selecting a red ball from it.

Hence

$$P(R) = P(ER) + P(MR) \quad (1)$$

But $P(ER) = \frac{1}{2} \times \frac{3}{8}$ (since there are 3 red balls out of 8 in the E box)

and $P(MR) = \frac{1}{2} \times \frac{6}{10}$ since there are 6 red balls out of 10 in the M box

Hence (1) becomes

$$\begin{aligned} P(R) &= \frac{1}{2} \times \frac{3}{8} + \frac{1}{2} \times \frac{6}{10} \\ &= \frac{3}{16} + \frac{3}{10} \\ &= \frac{39}{80} \end{aligned}$$

Now to find $P(B)$ the probability of selecting a black ball.

Using similar logic as above, we get

$$P(B) = P(EB) + P(MB) \quad (2)$$

But $P(EB) = \frac{1}{2} \times \frac{5}{8}$ (since there are 5 black balls out of 8 in the E box)

and $P(MB) = \frac{1}{2} \times 0 = 0$ since there are zero black balls out of 10 in the M box

Hence (2) becomes

$$\begin{aligned} P(B) &= \frac{1}{2} \times \frac{5}{8} \\ &= \frac{5}{16} \end{aligned}$$

Now to find $P(W)$ the probability of selecting a white ball.

Using similar logic as above, we get

$$P(W) = P(EW) + P(MW) \quad (3)$$

But $P(EW) = \frac{1}{2} \times 0$ (since there are zero white balls out of 8 in the E box)

and $P(MW) = \frac{1}{2} \times \frac{4}{10} = \frac{1}{5}$ since there are 4 white balls out of 10 in the B box

Hence (3) becomes

$$\begin{aligned} P(W) &= 0 + \frac{1}{5} \\ &= \frac{1}{5} \end{aligned}$$

Now to find the probability that the ball selected is either a red or a white, we need to find $P(R) + P(W)$ but from above, this is $\frac{39}{80} + \frac{1}{5} = \frac{11}{16}$

(b) What is the probability of selecting a red on the second try given that we selected a red on the first try (without placing it back into the box?)

Let A=Event that a red ball was selected on first try

Let B=Event that a red ball was selected on second try.

Then we are asked to find $P_A(B)$

But by Bayes rule,

$$P_A(B) = \frac{P(AB)}{P(A)} \quad (1)$$

Where $P(AB)$ is the probability of selecting a red ball on the first try and a red ball on the second try (without replacement).

$P(A)$ was found above in part (a) which is $\frac{39}{80}$

Now I need to find $P(AB)$. To do this, I used a tree diagram which is shown below.

From this I find that $P(AB) = \frac{187}{840}$

Another method to find $P(AB)$ is to say: it is the probability of selecting and red ball from first box and then the probability of selecting a red ball from the same box OR it is the probability of selecting and red ball from first box and then the probability of selecting a red ball from the second box OR it is the probability of selecting and red ball from second box and then the probability of selecting a red ball from the same box OR it is the

probability of selecting and red ball from second box and then the probability of selecting a red ball from the first box. This will result in the following computation:

$$\left[\frac{1}{2} \left(\frac{3}{8} \right) \times \frac{1}{2} \left(\frac{2}{7} \right) \right] + \left[\frac{1}{2} \left(\frac{3}{8} \right) \times \frac{1}{2} \left(\frac{6}{10} \right) \right] + \left[\frac{1}{2} \left(\frac{6}{10} \right) \times \frac{1}{2} \left(\frac{5}{9} \right) \right] + \left[\frac{1}{2} \left(\frac{6}{10} \right) \times \frac{1}{2} \left(\frac{3}{8} \right) \right] = \frac{187}{840}$$

which agrees with the number I obtained from the tree diagram.

Another method to find P(AB) is to say: Assume the red ball came from Box A, now do the calculations to find the chance of picking a red ball on second try. Now multiply this by the chance of the assumption being true. We get a number, say x. Next, assume the red ball came from the second box B, now do the calculation to find the chance of picking a red ball on second try. Now multiply this by the chance of the assumption being true. call this number y. Now add x + y. and this is P(AB). This is really the exact same thing as I did in the above alternative method, just expressed differently.

Hence, from (1) we finally get the conditional probability

$$P_A(B) = \frac{\frac{187}{840}}{\frac{39}{80}} = \frac{374}{819}$$

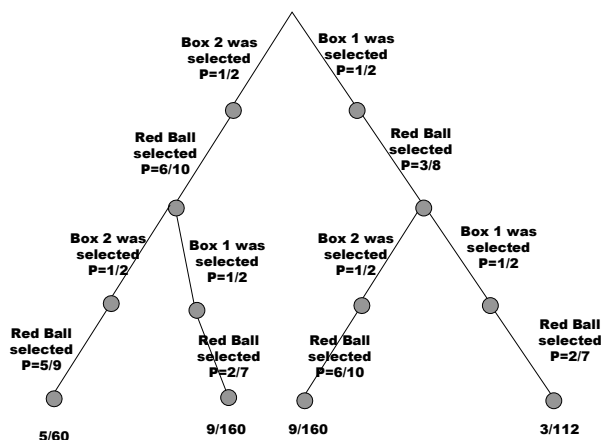

Tree diagram to find the probability of selecting a red on first try and a red on second try. The result is the sum of all the numbers at the leaves of the tree above. Hence the result is

$$5/60 + 9/160 + 9/160 + 3/112 = 187/840$$

(c) If both balls are red, what is the probability that they both came from the same box?

Let A=Event that both the first and second balls are red

Let B=Event that they both came from the same box

Hence we want to find

$$P_A(B) = \frac{P(AB)}{P(A)} \quad (1)$$

$P(A)$ is the probability of the first ball being red and then the second ball being red. From part(b) we found this probability to be $\frac{187}{840}$

Now $P(AB)$ is the probability that the first ball and the second ball both came from the same box and both balls are red.

Looking at the tree diagram above, I see that the 2 leaves that leads to this have the probability sum of $\frac{5}{60} + \frac{3}{112} = \frac{37}{336}$ (These are the right-most branch, and the left-most branch).

Hence (1) becomes

$$\begin{aligned} P_A(B) &= \frac{\frac{37}{336}}{\frac{187}{840}} \\ &= \frac{185}{374} \\ &= 0.49465 \end{aligned}$$

4.12.8 chapter 16, problem 3.19, Mary Boas , second edition

Suppose it is known that 1% of the population have a certain kind of cancer. It is also known that a test of this kind of cancer is positive in 99% of the people who have it but is also positive in 2% of the people who do not have it. What is the probability that a person who tests positive has cancer of this type?

Solution

Let A=Event that a person has cancer

Let B=Event that a test is positive.

We want to find $P_B(A)$

Using Baye's rule

$$\begin{aligned} P_B(A) &= \frac{P(BA)}{P(A)} \\ &= \frac{P(A)P_A(B)}{P(B)} \end{aligned}$$

$P(A)$ is the probability a person has cancer. This is given as 1% or 0.01

$P(B)$ is the probability that a test is positive, this is calculated as follows

$$P(B) = 99\% \times 1\% + 2\% \times (100\% - 1\%) = 0.99 \times 0.01 + 0.02 \times (0.99) = 0.0297$$

$P_A(B)$ is the probability that test is positive given the person has cancer= 99% = 0.99

Hence

$$\begin{aligned} P_B(A) &= \frac{P(A)P_A(B)}{P(B)} \\ &= \frac{0.01 \times 0.99}{0.0297} \\ &= \frac{0.0099}{0.0297} \\ &= 0.33333 \end{aligned}$$

So the chance a person has cancer given the test is positive is only 33%

4.12.9 chapter 16, problem 3.21, Mary Boas , second edition

2 people take turns tossing a pair of coins. The first who gets two tosses alike wins. What is the probability for winning for the first player and for the second player?

Solution

I make a tree diagram. From this I find the needed probability sequence.

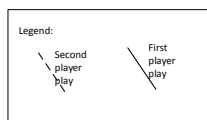
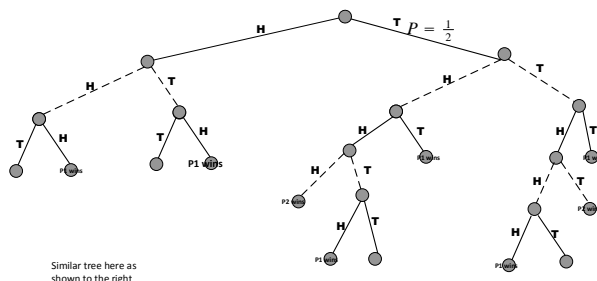

From diagram we see that the probability of player one winning after total of 3 tosses (by both players) is $4 \times \left(\frac{1}{2}\right)^3 = \frac{1}{2}$, (since there are 4 branches which leads to a win for

player one), and after 5 tosses $4 \times \left(\frac{1}{2}\right)^5 = \frac{1}{8}$ and so after 7 tosses probability of first player winning is $4 \times \left(\frac{1}{2}\right)^7 = \frac{1}{32}$, after 9 tosses, it is $4 \times \left(\frac{1}{2}\right)^9 = \frac{1}{128}$

So the probability of first player winning is

$$\begin{aligned} & \frac{1}{2} + \frac{1}{8} + \frac{1}{32} + \frac{1}{128} + \dots \\ &= \frac{1}{2} \left(1 + \frac{1}{2^2} + \frac{1}{2^4} + \frac{1}{2^6} + \dots \right) \\ &= \frac{1}{2} \left(1 + \left(\frac{1}{2}\right)^2 + \left(\frac{1}{2}\right)^4 + \left(\frac{1}{2}\right)^6 + \dots \right) \\ &= \frac{1}{2} \frac{1}{1 - \left(\frac{1}{2}\right)^2} \\ &= \frac{1}{2} \frac{4}{3} \\ &= \frac{2}{3} \end{aligned}$$

Hence the probability of the second player winning is $1 - \frac{2}{3} = \frac{1}{3}$

4.12.10 chapter 16, problem 4.1, Mary Boas , second edition

(a) There are 10 chairs in a row and 8 people to be seated, in how many way can you choose them?

There are $8!$ ways to arrange the 8 people.

For each one of these arrangements, there is $\binom{10}{8}$ ways to select 8 chairs out of the 10 chairs to seat each arrangement of the 8 people on.

Hence by the principle of counting, the final answer is

$$8! \times \binom{10}{8} = 8! \frac{10!}{(10-8)! \times 8!} = \frac{10!}{(10-8)!} \text{ which is the same as saying } \boxed{P_8^{10}}$$

So $P_8^{10} = 1,814,400$

(b) There are 10 questions on a test and you are to do 8 of them, in how many ways can we choose them?

There are $\binom{10}{8}$ ways to choose the 8 questions out of 10 without duplication.

$$\text{Hence } \binom{10}{8} = \frac{10!}{(10-8)! 8!} = \frac{10!}{(10-8)! 8!} = 45$$

(c) In part (a) what is the probability that the first 2 chairs in a row are vacant.

Here we want to find number of ways 2 chairs can be empty out of 10 chairs. This is

$$\binom{10}{2} = 45.$$

Hence the probability that the first 2 chairs are the empty pairs is just $\frac{1}{45}$ (one chance out of total possible 45).

(d) In part(b), what is the probability you omit the first 2 problems in the test?

First we find the number of ways not to select 2 questions out of 10. This is given by

$\binom{10}{2} = 45$, so the probability of not selecting any 2 questions is $\frac{1}{45}$, and since any 2 questions are equally likely not to be selected (we are not given any extra information to suggest otherwise), then the probability of not selecting the first is also $\frac{1}{45}$

(e) Explain why the answers to (a) and (b) are different, but the answers to (c) and (d) are the same.

The answers to (a) and (b) are different, because in (b) we are looking for one set of 8 questions, and the order how the questions are arranged within the set is not important. In (a), the order was important. That is why answer for (a) is much larger than (b).

Answer to (c) and (d) is the same since in both cases the order is not important.

4.12.11 chapter 16, problem 4.4, Mary Boas , second edition

5 cards are dealt from a shuffled deck. What is the probability that they are all of the same suite?

Answer

There are a total of $\binom{52}{5}$ ways to select 5 cards out of 52. (where the order of the 5 cards is not important).

There are $\binom{13}{5}$ ways to select 5 cards from one suite. and there are 4 ways to select one

suite. Hence number of ways to select 5 cards from the same suite is

$$4 \binom{13}{5}$$

So probability of selecting this will be $\frac{4 \binom{13}{5}}{\binom{52}{5}} = \boxed{1.98 \times 10^{-3}}$

5 cards are dealt from a shuffled deck. What is the probability that they are all diamond?

Answer

This is just $\frac{1}{4}$ of the above probability, since there is one out of 4 chance it is a diamond.

Hence the answer is $\frac{1}{4} \times 1.98 \times 10^{-3} = \boxed{4.95 \times 10^{-4}}$

5 cards are dealt from a shuffled deck. What is the probability that they are all face cards?

Answer

There are $3 \times 4 = 12$ face cards in a whole deck of cards (Jack, Queen, King).

The number of ways 5 cards can be selected from these is $\binom{12}{5}$

Hence the probability they are all face cards is $\frac{\binom{12}{5}}{\binom{52}{5}} = 3.047 \times 10^{-4}$

5 cards are dealt from a shuffled deck. What is the probability that the 5 cards are in sequence in the same suite?

Answer

This is the probability of being in the same suite and then of being in sequence.

Let A=event of being in sequence

Let B=Event of being from same suite

So want to find $P(AB)$

$$P(BA) = P_B(A) \times P(B)$$

To find $P_B(A)$, this is the probability of being in sequence given the hand is already from one suite, we need to find number of ways 5 cards in sequence can be selected out of one suite. That is $\{1, 2, 3, 4, 5\}, \{2, 3, 4, 5, 6\}, \dots, \{9, 10, J, Q, K\}$

so there are 9 ways this could happen. But there $\binom{13}{5}$ ways to select 5 cards from one suite. Hence the probability of straight 5 cards given one suite is $\frac{9}{\binom{13}{5}} = 7 \times 10^{-3}$

Now $P(B)$ was found first part of this problem, and it is 1.98×10^{-3}

Hence

$$\begin{aligned} P(BA) &= P_B(A) \times P(B) = 7 \times 10^{-3} \times 1.98 \times 10^{-3} \\ &= 1.386 \times 10^{-5} \end{aligned}$$

Another way to solve this: We want to find

$$\begin{aligned} \frac{\text{number of ways to select 5 cards all from same suite in sequence}}{\text{number of ways to select 5 card}} &= \frac{4 \times \binom{13}{5} \times \text{probability of those 5}}{\binom{52}{5}} \\ &= \frac{4 \times \binom{13}{5} \times \frac{9}{\binom{13}{5}}}{\binom{52}{5}} \\ &= 1.39 \times 10^{-5} \end{aligned}$$

4.12.12 chapter 16, problem 4.5, Mary Boas , second edition

In a family of 5 children, what is the probability that there are 2 boys and 3 girls?

Answer

Looking at any sequence of 5 children, such as $\{bbgbg\}$, there are 2^5 different sequences since for each position we can have either a boy or a girl (this is like looking at tail/head sequence generated from flipping a coin 5 times).

So the probability of any one sequence is $\frac{1}{2^5}$

Now the number of sequences with only 3 boys in them is $\binom{5}{3}$ which is the number of ways 3 positions can be selected out of 5 positions.

Hence the probability of having only 3 boys (and hence 2 girls) is $\frac{1}{2^5} \times \binom{5}{3} = \frac{5 \times 4}{2^5 \times 2} = \frac{5}{16}$

In a family of 5 children, what is the probability that the 2 oldest are boys and the others are girls?

Answer

Let A=Event the first 2 born children are boys

Let B=Event that the last 3 born children are girls.

We want to find $P(AB)$ the probability of A and B together.

$$P(AB) = P(A) P_A(B) \quad (1)$$

$P(A)$ is $\left(\frac{1}{2}\right)^2$ (since the chance of each child being a boy is $\frac{1}{2}$).

Now $P_A(B)$ is the probability of the last 3 children being girls given the first 2 children are boys. Since A and B are independent, then $P_A(B) = P(B)$ which is $\left(\frac{1}{2}\right)^3$

Hence from (1)

$$P(AB) = \left(\frac{1}{2}\right)^2 \left(\frac{1}{2}\right)^3 = \left(\frac{1}{2}\right)^5 = \frac{1}{32}$$

4.12.13 chapter 16, problem 4.7, Mary Boas , second edition

What is the probability that the 2 and 3 of clubs are next to each others in a shuffled deck?

Answer

Let E_1 = event of having the 2 card as the top of the deck

Let E_2 = event of having the 2 card as the bottom of the deck

Let E_3 = event having the 2 card somewhere in the middle of the deck.

Let E = event we are looking for. (i.e. the 2 and 3 cards next to each others)

So we want to find

$$P(E) = P(E_1)P_{E_1}(E) + P(E_2)P_{E_2}(E) + P(E_3)P_{E_3}(E) \quad (1)$$

But $P(E_1) = \frac{1}{52}$ since there is one position (the top) and there are 52 possible positions the card can be in.

Similarly, $P(E_2) = \frac{1}{52}$ since there is one position (the bottom) and there are 52 position.

$P(E_3) = \frac{50}{52}$ since there are 50 possible positions (not counting the top and bottom) out of 52 the card can be in.

Now need to find the conditional probabilities.

$P_{E_1}(E)$ this is the probability of having the 3 card below the 2 card, given the 2 card is in the top position. Clearly this is $\frac{1}{51}$ since there is 51 positions.

Similarly, $P_{E_2}(E)$ this is the probability of having the 3 card above the 2 card, given the 2 card is in the bottom position. Clearly this is $\frac{1}{51}$ also.

Now $P_{E_3}(E)$ is the probability of having the 3 card next to the 2 card given that the 2 card is somewhere in the middle. Now the 3 card can be above or below the 2 card. Hence the probability now is $\frac{2}{51}$

Now substitute all these values in (1) gives

$$\begin{aligned} P(E) &= P(E_1)P_{E_1}(E) + P(E_2)P_{E_2}(E) + P(E_3)P_{E_3}(E) \\ &= \frac{1}{52} \times \frac{1}{51} + \frac{1}{52} \times \frac{1}{51} + \frac{50}{52} \times \frac{2}{51} \\ &= \frac{1}{26} \end{aligned}$$

4.12.14 chapter 16, problem 4.8, Mary Boas , second edition

2 cards are drawn from a shuffled deck. What is the probability that both are aces?

Answer

Let A = event first card is an ace.

Let B = event the second card is an ace.

We want to find $P(AB) = P(A) P_A(B)$

$P(A)$ = The probability of first card being an ace is $\frac{4}{52}$

Now, Given the first card is an ace, the probability of the second card is an ace is $\frac{3}{51}$

Hence $P_A(B) = \frac{3}{51}$

So

$$P(AB) = \frac{4}{52} \times \frac{3}{51} = \frac{1}{221}$$

2 cards are drawn from a shuffled deck. If you know one is an ace, what is the probability that both are aces?

Answer

Let A = event one of the two cards is an ace.

Let B = event both are an ace

Let C = event first is an ace

Let D = event second is an ace.

We want to find $P_A(B) = \frac{P(AB)}{P(A)} = \frac{P(B)P_B(A)}{P(A)} = \frac{P(B)}{P(A)}$ since $P_B(A) = 1$ (because given both are an ace, it is certain that one is an ace).

$$P(A) = P(C) + P(D) - P(CD)$$

But $P(CD)$ is the probability of both being an ace, which is the same as $P(B)$ which was found in part(a) to be $\frac{1}{221}$

$$\text{And } P(C) = P(D) = \frac{4}{52}$$

$$\text{Hence } P(A) = \frac{4}{52} + \frac{4}{52} - \frac{1}{221} = \frac{33}{221}$$

Now $P(AB) = P(B)P_B(A)$, but $P(B) = \frac{1}{221}$ from part(a).

Hence

$$\begin{aligned} P_A(B) &= \frac{\left(\frac{1}{221}\right)}{\left(\frac{33}{221}\right)} \\ &= \frac{1}{33} \end{aligned}$$

2 cards are drawn from a shuffled deck. If you know that one is an ace of spades, what is the probability that both are aces?

Answer

Let A = event one of the two cards is an ace of spades.

Let B = event both are an ace

Let C = event first card is an ace of spades

Let D = event second card is an ace of spades

We want to find

$$P_A(B) = \frac{P(AB)}{P(A)} = \frac{P(B)P_B(A)}{P(A)} \quad (1)$$

$$\text{Now } P_B(A) = P_B(C) + P_B(D) = \frac{1}{4} + \frac{1}{4} = \frac{1}{2}$$

Hence (1) becomes

$$P_A(B) = \frac{P(B)P_B(A)}{P(A)} = \frac{1}{2} \frac{P(B)}{P(A)} \quad (2)$$

Now we need to find $P(A)$ and $P(B)$.

$$P(A) = P(C) + P(D) - P(CD)$$

But $P(CD)$ is the probability of both cards being an ace of spades, this is zero since there is only ONE card which is an ace of spades and so we can not have both being an ace of spades.

$$\text{Now } P(C) = P(D) = \frac{1}{52}$$

$$\text{Hence } P(A) = \frac{1}{52} + \frac{1}{52} = \frac{1}{26}$$

To find $P(B)$, this was found in part(a) to be $\frac{1}{221}$

Hence (2) becomes

$$\begin{aligned} P_A(B) &= \frac{1}{2} \frac{\left(\frac{1}{221}\right)}{\left(\frac{1}{26}\right)} \\ &= \frac{1}{17} \end{aligned}$$

4.12.15 chapter 16, problem 4.10, Mary Boas , second edition

What is the probability that you and your friend have different birthdays? (assume year is 365 days). What is the probability that 3 people have different birthdays? show that the probability that n people have all different birthdays is given by

$$P = \left(1 - \frac{1}{365}\right)\left(1 - \frac{2}{365}\right)\left(1 - \frac{3}{365}\right) \cdots \left(1 - \frac{n-1}{365}\right)$$

Estimate p for $n \ll 365$ by calculating $\ln p$. Find the smallest n for which $p < \frac{1}{2}$ hence show that for a group of 23 people or more the probability is greater than $\frac{1}{2}$ that 2 of them will have the same birthday.

Answer

Let A=event that second person have different birthday from the first

Let B=event that 3rd person have different birthday from the second person.

Let C=event that all 3 have different birthdays

$$P(A) = \frac{364}{365}$$

So $P(C) = P(AB) = P(A) P_A(B)$

But $P_A(B)$ is the probability that 3rd person have different birthday from second, given that the second have a different birthday from the first. This leaves only 363 days to select a birthday from. Hence $P_A(B) = \frac{363}{365}$

Hence

$$\begin{aligned} P(C) &= \left(\frac{364}{365}\right)\left(\frac{363}{365}\right) \\ &= \left(1 - \frac{1}{365}\right)\left(1 - \frac{2}{365}\right) \end{aligned}$$

So when we add a 4th person we will get the probability that they have different birthdays

$$P = \left(1 - \frac{1}{365}\right)\left(1 - \frac{2}{365}\right)\left(1 - \frac{3}{365}\right)$$

Continue this for n people we get,

$$p = \overbrace{\left(1 - \frac{1}{365}\right)}^2 \overbrace{\left(1 - \frac{2}{365}\right)}^3 \cdots \overbrace{\left(1 - \frac{n-1}{365}\right)}^n$$

Take the log of both sides we get

$$\begin{aligned}\ln p &= \ln \left[\left(1 - \frac{1}{365}\right) \left(1 - \frac{2}{365}\right) \cdots \left(1 - \frac{n-1}{365}\right) \right] \\ &= \ln \left(1 - \frac{1}{365}\right) + \ln \left(1 - \frac{2}{365}\right) \cdots + \ln \left(1 - \frac{n-1}{365}\right)\end{aligned}\quad (1)$$

But $\ln(1+x) = x$ for small x (i.e. for $n \ll 365$)

Hence (1) becomes

$$\begin{aligned}\ln p &= -\frac{1}{365} - \frac{2}{365} \cdots - \frac{n-1}{365} \\ &= -\frac{1+2+3+\cdots+(n-1)}{365}\end{aligned}$$

But $1+2+3+\cdots+(n-1) = [(n-1)+1] \times \frac{(n-1)}{2}$ (by Gauss summation formula)

So we get

$$\begin{aligned}\ln p &= -\frac{n \times \frac{(n-1)}{2}}{365} \\ &= -\frac{n \times (n-1)}{2 \times 365}\end{aligned}\quad (2)$$

The above is an estimate of $\ln p$ for $n \ll 365$

Now need to Find the smallest n for which $p < \frac{1}{2}$

$p < \frac{1}{2}$ implies $\ln p < \ln \frac{1}{2}$

Hence $\ln p < -\ln 2$

So $\ln p < -0.69315$

so from (2)

$$\begin{aligned}\frac{n \times (n-1)}{2 \times 365} &> 0.69315 \\ n \times (n-1) &> 506.00 \\ n^2 - n - 506 &> 0\end{aligned}$$

Hence $n = 23$ or $n = -22$

since n is number of people, we select positive value. Hence for $n > 23$ there is a chance just less than $\frac{1}{2}$ that no 2 people will have the same birthday, or there is a chance just over 50% that 2 people will have the same birthday.

4.12.16 chapter 16, problem 4.11 , Mary Boas , second edition

The following game was being played on a busy street: Observe the last 2 digits on each license plate. What is the probability of observing at least 2 cars with the same last 2 digits among the first 5 cars? 10 cars? 15 cars? How many cars must you observe in order for the probability to be greater than 50% of observing 2 cars with the same last 2 digits?

Answer

This is similar to problem 4.10.

Replace the number of days in a year by the number of numbers, which is 100 numbers (2 digits, 00, 01, ..., 99 is 100 numbers).

Hence I can use the formula obtained in 4.10

$$P = \left(1 - \frac{1}{100}\right)\left(1 - \frac{2}{100}\right)\left(1 - \frac{3}{100}\right) \cdots \left(1 - \frac{n-1}{100}\right)$$

and for small n compared to 100

$$\ln p = -\frac{n \times (n-1)}{2 \times 100}$$

So for $n = 5$ we get

$$\begin{aligned} \ln p &= -\frac{5 \times (5-1)}{2 \times 100} \\ \ln p &= -\frac{1}{10} \end{aligned}$$

Solution is: $p = 0.90484$

The above is the probability of all 5 cars having different 2 digits numbers. Hence Probability of observing at least 2 cars with same last 2 digits is

$$1 - p = 1 - 0.90484 = 0.09516$$

Notice that is was based on the approximation formula. To get an exact number, I would write

$$\begin{aligned}
 P &= \overbrace{\left(1 - \frac{1}{100}\right)}^2 \left(1 - \frac{2}{100}\right) \left(1 - \frac{3}{100}\right) \overbrace{\left(1 - \frac{4}{100}\right)}^5 \\
 &= 0.90345
 \end{aligned}$$

Hence Probability of observing at least 2 cars with same last 2 digits is

$$1 - 0.90345 = 0.09655$$

To solve this for $n = 10$

$$\text{From } \ln p = -\frac{n \times (n-1)}{2 \times 100}$$

$$\begin{aligned}
 \ln p &= -\frac{10 \times (10 - 1)}{2 \times 100} \\
 \ln p &= -0.45
 \end{aligned}$$

Solution is: $p = 0.63763$

Hence Probability of observing at least 2 cars with same last 2 digits is

$$1 - 0.63763 = 0.36237$$

For $n = 15$

$$\begin{aligned}
 \ln p &= -\frac{15 \times (15 - 1)}{2 \times 100} \\
 \ln p &= -1.05
 \end{aligned}$$

Solution is: $p = 0.34994$

Hence Probability of observing at least 2 cars with same last 2 digits is

$$1 - 0.34994 = 0.65006$$

To find how many cars one must observe to get a probability of more than 50% of having at least 2 cars with same last 2 digits, we solve for $p = \frac{1}{2}$

$$\begin{aligned}\ln p &= -\frac{n \times (n - 1)}{2 \times 100} \\ \ln \frac{1}{2} &= -\frac{n \times (n - 1)}{2 \times 100} \\ -\ln 2 &= -\frac{n \times (n - 1)}{2 \times 100}\end{aligned}$$

Solution is: $\{[n = -11.285], [n = 12.285]\}$

Hence $n = 13$

4.12.17 chapter 16, problem 4.15 , Mary Boas , second edition

Problem 4.15 Chapter 16 (Mary Boas second edition)

By Nasser Abbasi

A	B	
A		B
A B		
	A	B
B	A	
	A B	
	B	A
B		A
		B A

Box 1 Box 2 Box 3

Maxwell-Blotzman distribution of 2 balls into 3 boxes. Balls are distinguishable from each others, one ball labeled A and the other B. Total number of ways pf putting the 2 balls into the 3 boxes is given by $3^2=9$

o	o	
o		o
	o	o

Box 1 Box 2 Box 3

Fermi-Dirac distribution of 2 balls into 3 boxes. Balls are NOT distinguishable, hence each is a circle. In addition, each box can have only ONE ball in it at a time. Number of ways of putting 2 balls into 3 boxes is $C(3,2)=3$

o	o	
o		o
o o		
	o o	
o		o
		o o

Box 1 Box 2 Box 3

Bose-Einstein distribution of 2 balls into 3 boxes. Balls are NOT distinguishable (just like with the Fermi-Dirac), however, here we can put more than one ball in the same box at one time (unlike the Fermi-Dirac). Number of ways of putting 2 balls into 3 boxes is $C(3+1,2)=6$ and the probability of each one permutation is $1/6$ (each is equally likely).

4.12.18 chapter 16, problem 4.17 , Mary Boas , second edition

Find number of ways of putting 2 particles in 4 boxes according to the 3 kinds of statistics.

Answer

Let n be the number of Boxes, and N be the number of balls.

For Maxwell-Boltzmann (MB) it is n^N . Hence the answer is $4^2 = 16$

For Fermi-Dirac (FM), it is ${}_n C_N = {}_4 C_2 = \binom{4}{2} = \boxed{6}$

For Bose-Einstein (BE) it is ${}_{n-1+N} C_N = \binom{4-1+2}{2} = \binom{5}{2} = 10$

4.12.19 chapter 16, problem 4.21, Mary Boas, second edition

Find the number of ordered triplets of non-negative integers a, b, c whose sum adds to a given positive integer n

Answer

If we imagine the number n written as 1111 \cdots 111 and then imagine we put one vertical bar to the left most and to the right most like this: | 1111 \cdots 111 |, then the problem becomes on how many unique partitions we can create in-between these 2 vertical bars by using 2 new vertical bars. A partition here is the same as a box.

For example, the following is an example of 2 different partitions created for $n = 8$

$$| 111 | 1111 | 1 |$$

$$| 1 | 11111 | 11 |$$

Note that We can also create an empty partition, as follows

$$| 1 | | 1111111 |$$

When we create an empty partition between the 2 vertical bars, it is as if there is a 0 in there.

Hence the problem becomes a question of how many way can we insert the 2 vertical bar among n different objects.

To count this, we start by putting the first vertical bar before the first object:

$$| | 1111111 |$$

So now the second bar can go before or after the second object, or after the third object, or after the 4th object, etc... until we get to the n th object, where it can go after it. Hence there are n choices for the second bar.

Now, the first bar can be put after the first object as this:

$$| 1 | 1111111 |$$

So now the second bar can go into any of $n - 1$ positions.

We continue this way, until we get to the last object, where we can put the first bar after it, as this:

$$| 11111111 | |$$

Now the second vertical bar have only one position to go which is after the first vertical bar.

So, the first vertical bar has been placed in $m = n + 1$ positions, and for each one of these positions, the second vertical bar has been put in $k + 1$ positions where k indicates the number of object to the right of the first vertical bar at the time.

So, for example, for $n = 3$, we have $n + 1$ possible positions for the second vertical bar when the first vertical bar at the left of the first object. Then we have n possible positions for the second vertical bar when the first vertical bar to the right of the first object, then we have $n - 1$ possible positions for the second vertical bar when the first vertical bar to the right of the second object, and we have $n - 2$ or 1 possible positions for the second vertical bar when the first vertical bar to the right of the third and final object.

This is the same as the number of ways to choose r object at a time from n objects.

Hence for $n = 3$ we have $(n + 1) + (n) + (n - 1) + (n - 2) = 4n - 2 = 10$

So in general, we have $(n + 1) + (n) + \dots + 1$ possible ordered triples.

This is, using Gauss summation trick, is the same as

$$(n + 2) \frac{(n + 1)}{2}$$

But this is the same as $\frac{(n+2)!}{n! 2!}$ which is the same as $\binom{n + 2}{n}$

But note that the Bose-Einstein statistics with the number of boxes being fixed at 3 gives

$$\binom{3 - 1 + n}{n} = \binom{2 + n}{n}$$

This is the same as the Bose-Einstein statistics with the number of boxes being fixed at 3.