

HW 10

MATH 121B

Spring 2004  
UC BERKELEY

Nasser M. Abbasi

Spring 2004

Compiled on April 17, 2021 at 7:15pm

# Contents

1	chapter 13, problem 6.3 Mary Boas, second edition	2
2	chapter 13, problem 7.2 Mary Boas, second edition	9
3	chapter 13, problem 7.15 Mary Boas, second edition	11
4	chapter 13, problem 7.16 Mary Boas, second edition	15
5	chapter 13, problem 7.17 Mary Boas, second edition	19
6	chapter 13, problem 8.1, Mary Boas, second edition.	21
7	chapter 13, problem 8.2 Mary Boas, second edition	23
8	chapter 13, problem 8.3, Mary Boas, second edition.	25

# 1 chapter 13, problem 6.3 Mary Boas, second edition

---

## Problem

(my note: I'll use  $f$  for frequency instead of book  $\nu$  (mu)) since  $\nu$  looks very close to  $v$  the speed of the wave, to avoid confusion).

Separate the wave equation in 2D rectangular coordinates. Consider the membrane shown, rigidly attached to its supports along the sides. Show that its characteristic frequencies

are  $f_{nm} = \left(\frac{v}{2}\right)\sqrt{\left(\frac{n}{a}\right)^2 + \left(\frac{m}{b}\right)^2}$  where  $n, m$  are positive integers and sketch the normal modes of vibration corresponding to the first few frequencies. Next suppose the membrane is square, show that in this case there may be two or more normal modes of vibration corresponding to a single frequency. Sketch several normal modes giving rise to the same frequency.

## Solution

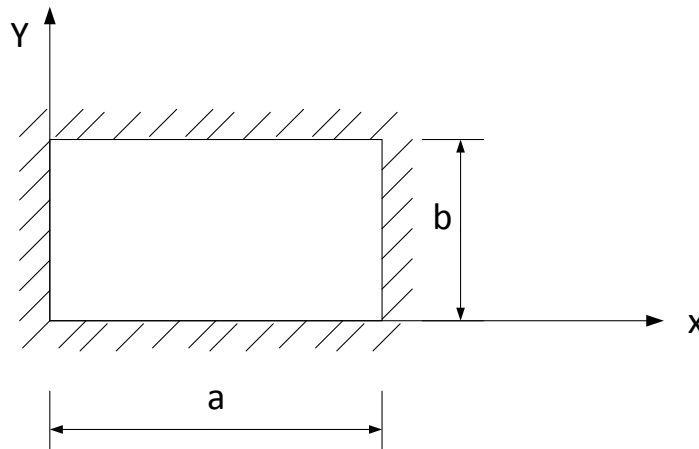

Wave equation in rectangular coordinates is  $\frac{\partial^2 z}{\partial x^2} + \frac{\partial^2 z}{\partial y^2} = \frac{1}{v} \frac{\partial^2 z}{\partial t^2}$

Let solution

$$z(x, y, t) = X(x)Y(y)T(t)$$

Then we get after substitution

$$YTX'' + XTY'' = \frac{1}{v}XYT''$$

Divide by  $YTX$  we get

$$\frac{X''}{X} + \frac{Y''}{Y} = \frac{1}{v} \frac{T''}{T}$$

Each term above is a constant since no one term depend on more than one variable in the others.

$$\text{So, } \frac{X''}{X} = \text{constant, } \frac{Y''}{Y} = \text{constant, } \frac{1}{v} \frac{T''}{T} = \text{constant}$$

$$\text{Let } \frac{X''}{X} = -k_x^2$$

$$\text{Let } \frac{Y''}{Y} = -k_y^2$$

$$\text{So } \frac{1}{v} \frac{T''}{T} = -k_x^2 - k_y^2 = -k_t^2$$

So the 3 ODE equations are

$$\frac{X''}{X} = -k_x^2 \tag{1}$$

$$\frac{Y''}{Y} = -k_y^2 \tag{2}$$

$$\frac{1}{v^2} \frac{T''}{T} = -k_x^2 - k_y^2 = -(k_x^2 + k_y^2) = -v^2(k_x^2 + k_y^2) \tag{3}$$

equation (1) is an ODE whose solution is cos, sin

$$X(x) = \begin{cases} \cos k_x x \\ \sin k_x x \end{cases}$$

Similarly

$$Y(y) = \begin{cases} \cos k_y y \\ \sin k_y y \end{cases}$$

similarly

$$T(t) = \begin{cases} \cos\left(t\sqrt{v^2(k_x^2 + k_y^2)}\right) \\ \sin\left(t\sqrt{v^2(k_x^2 + k_y^2)}\right) \end{cases}$$

Hence the general solution is

$$z(x, y, t) = \begin{cases} \cos k_x x \\ \sin k_x x \end{cases} \begin{cases} \cos k_y y \\ \sin k_y y \end{cases} \begin{cases} \cos\left(t\sqrt{v^2(k_x^2 + k_y^2)}\right) \\ \sin\left(t\sqrt{v^2(k_x^2 + k_y^2)}\right) \end{cases}$$

So we have a total of 6 possible general solutions

Now apply boundary conditions to remove solutions that can not be fitted.

Since membrane is fixed at  $y = 0$ , then we want  $z = 0$  when  $y = 0$  hence we reject the  $\cos k_y y$  since that is not zero at  $y = 0$

And since we want  $z = 0$  when  $x = 0$  hence we reject the  $\cos k_x x$  since that is not zero at  $x = 0$

So now our solution looks like

$$z(x, y, t) = \sin(k_x x) \sin(k_y y) \begin{cases} \cos\left(t\sqrt{v^2(k_x^2 + k_y^2)}\right) \\ \sin\left(t\sqrt{v^2(k_x^2 + k_y^2)}\right) \end{cases}$$

Now need to find  $k_x$  and  $k_y$

Since membrane is also fixed at  $y = b$  then we want  $z = 0$  when  $y = b$ . hence we want  $\sin(k_y b) = 0$  then happens when  $k_y b = m\pi$  for an integer  $m$

So

$$k_y = \frac{m\pi}{b}$$

The same for  $k_x$  we want  $z = 0$  when  $x = a$ . hence we want  $\sin(k_x a) = 0$  then happens when  $k_x a = n\pi$  for some integer  $n$ , so

$$k_x = \frac{n\pi}{a}$$

Hence the general solution now looks like

$$z(x, y, t) = \sin\left(\frac{n\pi}{a}x\right) \sin\left(\frac{m\pi}{b}y\right) \left\{ \begin{array}{l} \cos\left(vt\sqrt{\left(\frac{n\pi}{a}\right)^2 + \left(\frac{m\pi}{b}\right)^2}\right) \\ \sin\left(vt\sqrt{\left(\frac{n\pi}{a}\right)^2 + \left(\frac{m\pi}{b}\right)^2}\right) \end{array} \right.$$

$$z(x, y, t) = \sin\left(\frac{n\pi}{a}x\right) \sin\left(\frac{m\pi}{b}y\right) \left\{ \begin{array}{l} \cos\left(\pi vt\sqrt{\left(\frac{n}{a}\right)^2 + \left(\frac{m}{b}\right)^2}\right) \\ \sin\left(\pi vt\sqrt{\left(\frac{n}{a}\right)^2 + \left(\frac{m}{b}\right)^2}\right) \end{array} \right. \quad (4)$$

Now, from the general form of a wave equation, which can be written as  $z = A \cos(\omega t)$  or  $A \sin(\omega t)$  where  $\omega$  is the angular velocity in radian per second.

Hence by comparing to above, we see that

$$\pi vt\sqrt{\left(\frac{n}{a}\right)^2 + \left(\frac{m}{b}\right)^2} = \omega t$$

$$\pi v\sqrt{\left(\frac{n}{a}\right)^2 + \left(\frac{m}{b}\right)^2} = \omega$$

but  $\omega = 2\pi f$  where  $f$  is the frequency in hertz or cycles per seconds.

hence

$$f = \frac{v}{2} \sqrt{\left(\frac{n}{a}\right)^2 + \left(\frac{m}{b}\right)^2}$$

Which is what we are required to show.

To plot the normal modes of vibrations, need to find where the solutions are zero as I modify  $n, m$ . from (4), looking at the space components of the solution since that is what is of interest here,

$$z(x, y) = \sin\left(\frac{n\pi}{a}x\right) \sin\left(\frac{m\pi}{b}y\right)$$

For  $n = 1, m = 1$

$$z(x, y, t) = \sin\left(\frac{\pi}{a}x\right) \sin\left(\frac{\pi}{b}y\right)$$

This is zero when  $x = a$  or  $y = b$  hence the whole membrane will vibrate internally except at boundaries.

$$n = 2, m = 1$$

$$z(x, y, t) = \sin\left(\frac{2\pi}{a}x\right) \sin\left(\frac{\pi}{b}y\right)$$

This is zero when  $x = a$  and  $x = \frac{a}{2}$  or  $y = b$  Hence we have a normal mode at line  $x = a/2$  (see diagram below).

$$n = 3, m = 1$$

$$z(x, y, t) = \sin\left(\frac{3\pi}{a}x\right) \sin\left(\frac{\pi}{b}y\right)$$

This is zero when  $x = a$  and  $x = \frac{a}{3}, x = \frac{2a}{3}$  or  $y = b$  Hence we have a normal mode at line  $x = a/3$  and  $x = \frac{2a}{3}$  line (see diagram below).

$$n = 1, m = 2$$

$$z(x, y, t) = \sin\left(\frac{\pi}{a}x\right) \sin\left(\frac{2\pi}{b}y\right)$$

This is zero when  $x = a$  and or  $y = \frac{b}{2}$  Hence we have a normal mode at line  $y = \frac{b}{2}$  line (see diagram below).

$$n = 1, m = 3$$

$$z(x, y, t) = \sin\left(\frac{\pi}{a}x\right) \sin\left(\frac{3\pi}{b}y\right)$$

This is zero when  $x = a$  or  $y = b$  and  $y = \frac{b}{3}, y = \frac{2b}{3}$  Hence we have a normal mode at line  $y = b/3$  and  $y = \frac{2b}{3}$  line (see diagram below).

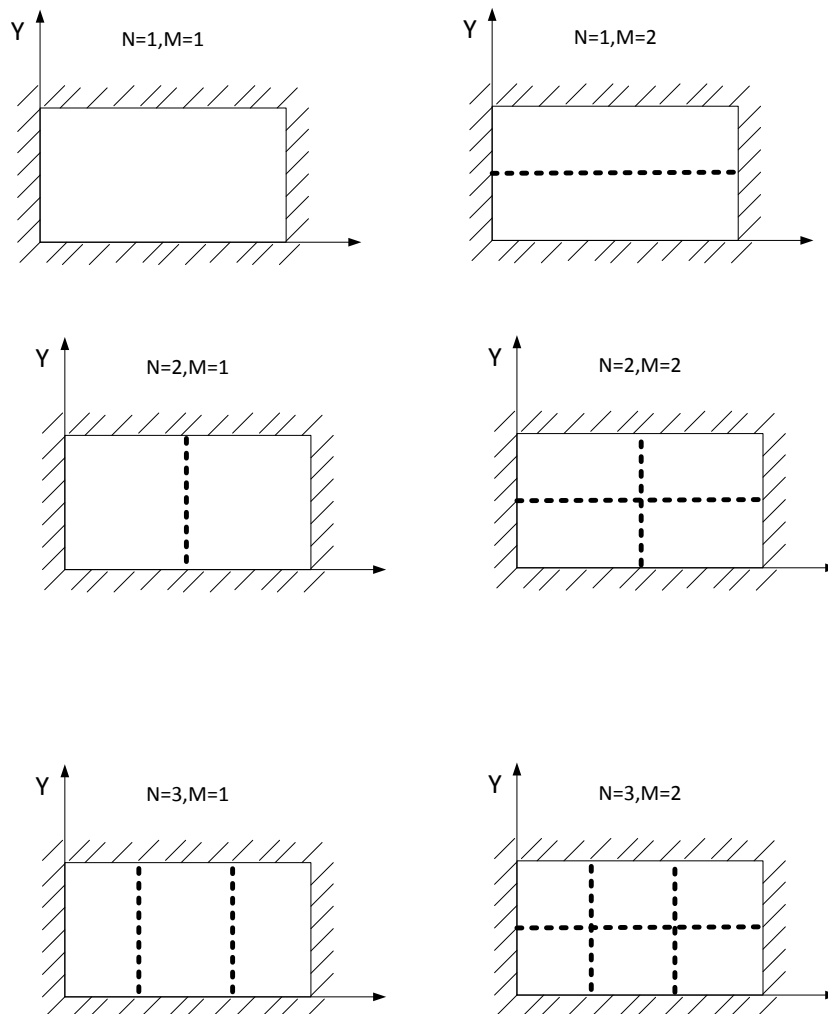

When the membrane is square, we have  $a = b$  hence the solution becomes

$$z(x, y, t) = \sin\left(\frac{n\pi}{a}x\right) \sin\left(\frac{m\pi}{a}y\right) \begin{cases} \cos\left(\pi vt \sqrt{\left(\frac{n}{a}\right)^2 + \left(\frac{m}{a}\right)^2}\right) \\ \sin\left(\pi vt \sqrt{\left(\frac{n}{a}\right)^2 + \left(\frac{m}{a}\right)^2}\right) \end{cases}$$



So, the frequency of the wave in the membrane takes values of

$$f = \frac{v}{2} \sqrt{\left(\frac{n}{a}\right)^2 + \left(\frac{m}{a}\right)^2}$$
$$f = \frac{v}{2a} \sqrt{n^2 + m^2}$$

This shows that for example, for  $n = 7$  and  $m = 1$  we will get the same frequencies as for  $n = 1$  and  $m = 7$ . hence we will get two or more modes of vibrations for the same frequency.

## 2 chapter 13, problem 7.2 Mary Boas, second edition

---

Find steady state temp. distribution inside a sphere of  $r = 1$  when the surface temp. is  $u = \cos \theta - (\cos \theta)^3$

### Solution

Need to use Laplace equation here. The basic solution to this problem is derived and given in text book at page 568

$$u(r, \theta, \phi) = r^l P_l^m(\cos \theta) \begin{cases} \sin m\phi \\ \cos m\phi \end{cases} \quad (1)$$

Where  $l$  is a constant (one that occurs in associated Legendre equation, equation 10.1 in text, page 504):

$$(1 - x^2)y'' - 2xy' + \left[ l(l + 1) - \frac{m^2}{1 - x^2} \right] y = 0$$

and  $P_l^m(x)$  is the associated Legendre functions (solution of the associated Legendre equation). and  $r, \theta, \phi$  are the spherical coordinates.

Since the temp. at the surface is a function of  $\theta$  then I can not remove the dependency of the solution on  $\theta$  as we have done in other problems. However, the solution is independent of  $\phi$  so  $m$  must be zero, and we can drop that  $\phi$  dependency, hence the basic solution becomes

$$u(r, \theta) = r^l P_l(\cos \theta) \quad (2)$$

Since a general solution is a sum of these solutions, we get

$$u(r, \theta) = \sum_{l=0}^{\infty} c_l r^l P_l(\cos \theta) \quad (3)$$

When  $r = 1$

$$u(1, \theta) = \cos \theta - (\cos \theta)^3 = \sum_{l=0}^{\infty} c_l r^l P_l(\cos \theta) \quad (4)$$

Writing  $\cos \theta = x$ , I see that  $\cos \theta - (\cos \theta)^3 = x - x^3$  But  $P_3(x) = \frac{-3}{2}x + \frac{5}{2}x^3$  and  $P_1(x) = x$

Hence I need a combination of  $P_3(x)$  and  $P_1(x)$  which will add to  $x - x^3$  so I can put that on the LHS of (4) to solve for the  $c_l$

$$\text{Try } \frac{4}{10}P_1(x) - \frac{2}{5}P_3(x) = \frac{4}{10}(x) - \frac{2}{5}\left(\frac{-3}{2}x + \frac{5}{2}x^3\right) = \frac{4}{10}x + \frac{6}{10}x - x^3 = x - x^3$$

Which is what we want.

Hence (4) can be written as

$$u(1, \theta) = \frac{2}{5}P_1(\cos \theta) - \frac{2}{5}P_3(\cos \theta) = \sum_{l=0}^{\infty} c_l r^l P_l(\cos \theta) \quad (5)$$

Expanding the sum and compare  $c_l$  I only need to go up to  $l = 3$

$$\frac{2}{5}P_1(\cos \theta) - \frac{2}{5}P_3(\cos \theta) = c_0 r^0 P_0(\cos \theta) + c_1 r^1 P_1(\cos \theta) + c_2 r^2 P_2(\cos \theta) + c_3 r^3 P_3(\cos \theta)$$

Hence

$$c_1 = \frac{2}{5}$$

$$c_3 = -\frac{2}{5}$$

All other  $c_l$  are zero

So final solution from (3) is

$$u(r, \theta) = \sum_{l=0}^{\infty} c_l r^l P_l(\cos \theta)$$

$$= \frac{2}{5} r P_1(\cos \theta) - \frac{2}{5} r^3 P_3(\cos \theta)$$

### 3 chapter 13, problem 7.15 Mary Boas, second edition

$r$  and  $\theta$  in (1.9) should be included. Replace  $c_1 r$  in (1.11) by  $(a_1 r + b_1 r^{-1})$ .

15. A sphere initially at  $0^\circ$  has its surface kept at  $100^\circ$  from  $t = 0$  on (for example, a frozen potato in boiling water!). Find the time-dependent temperature distribution. *Hint*: Subtract  $100^\circ$  from all temperatures and solve the problem; then add the  $100^\circ$  to the answer. Can you justify this procedure? Show that the Legendre function required for this problem is  $P_0$  and the  $r$  solution is  $(1/\sqrt{r})J_{1/2}$  or  $j_0$  [see (17.4) in Chapter 12]. Since spherical Bessel functions can be expressed in terms of elementary functions, the series in this problem can be thought of as either a Bessel series or a Fourier series. Show that the results are identical.

Figure 1: the Problem statement

#### Solution

Since we want the time-dependent solution, we use the heat diffusion equation

$$\nabla^2 u = \frac{1}{\alpha^2} \frac{\partial u}{\partial t}$$

The heat equation in spherical coordinates is given by equation 7.5 on page 567, plus an additional term called  $\lambda$  as was derived in class lecture, where  $\lambda = k^2 \alpha^2$ , and  $T(t) = e^{-k^2 \alpha^2 t}$ . Hence the equation is

$$\frac{1}{R(r)} \frac{d}{dr} \left( r^2 \frac{dR}{dr} \right) + \frac{1}{\Theta \sin \theta} \frac{d}{d\theta} \left( \sin \theta \frac{d\Theta}{d\theta} \right) - \frac{m^2}{\sin^2 \theta} + (k^2 \alpha^2) r^2 = 0$$

Where  $m$  is a constant to make  $\Phi(\phi)$  periodic as per page 567 in text. Using separation of variables we obtained as per lecture notes, the general solution is

$$u(r, \theta, \phi, t) = e^{-(k^2 \alpha^2) t} \begin{cases} \cos m\phi \\ \sin m\phi \end{cases} P_l^m(\cos \theta) \overbrace{\frac{1}{\sqrt{r}} J_{l+\frac{1}{2}}(kr)}^{R(r) \text{ solution}} \quad (1)$$

But from book, equation 17.4, on page 518, we have  $j_l(r) = \sqrt{\frac{1}{r}} J_{l+\frac{1}{2}}(r)$  Where  $j_l(r)$  is the spherical Bessel function, then  $j_l(kr) = \sqrt{\frac{1}{r}} J_{l+\frac{1}{2}}(kr)$ , so (1) is written in terms of spherical Bessel functions as

$$u(r, \theta, \phi, t) = e^{-(k^2 \alpha^2)t} \begin{cases} \cos m\phi \\ \sin m\phi \end{cases} P_l^m(\cos \theta) j_l(kr) \quad (2)$$

Equation (2) is the general solution of heat equation for spherical coordinates.

Since of symmetry w.r.t.  $\theta$  and  $\phi$  in the solution (since sphere surface temp does not depend on  $\theta$  nor  $\phi$ ), we can drop the terms that depends on  $\theta$  by setting  $m = 0$ , and set  $l = 0$  since we do not want singularity at origin which we assumed in the center of the sphere, therefore (2) becomes

$$u(r, t) = e^{-(k^2 \alpha^2)t} j_0(kr) \quad (3)$$

Now,  $u = 0$  for time  $t > 0$  when  $r = L$ , where  $L = \text{radius of the sphere}$ , hence for this to occur,  $j_0(kL)$  must be zero, so we want  $kL$  to be the zeros of the spherical coordinate function. Since  $j_0(x) = \frac{\sin x}{x}$  (from equation 17.4 page 518), then we see that  $j_0(kL) = 0$  implies  $\sin(kL) = 0$  or  $kL = n\pi$  or  $k = \frac{n\pi}{L}$  for integer  $n$ .

Hence now (3) becomes

$$\begin{aligned} u(r, t) &= e^{-\left(\left(\frac{n\pi}{L}\right)^2 \alpha^2\right)t} j_0\left(\frac{n\pi}{L}r\right) \\ &= e^{-\left(\frac{n\pi}{L}\alpha\right)^2 t} j_0\left(\frac{n\pi r}{L}\right) \end{aligned} \quad (4)$$

This is the basic candidate solution, which is in terms of  $j_0$  as is required to show. The general solution is a sum of these solutions

$$u(r, t) = \sum c_n e^{-\left(\left(\frac{n\pi}{L}\right)^2 \alpha^2\right)t} j_0\left(\frac{n\pi}{L}r\right)$$

Write  $j$  in terms of sin since easier to deal with. (equation 17.4 in book)

$$\begin{aligned} u(r, t) &= \sum c_n e^{-\left(\left(\frac{n\pi}{L}\right)^2 \alpha^2\right)t} \frac{\sin \frac{n\pi r}{L}}{\frac{n\pi r}{L}} \\ u(r, t) &= \sum c_n \frac{L}{n\pi r} e^{-\left(\frac{n\pi}{L}\alpha\right)^2 t} \sin \frac{n\pi r}{L} \\ u(r, t) &= \sum z_n \frac{1}{r} e^{-\left(\frac{n\pi}{L}\alpha\right)^2 t} \sin \frac{n\pi r}{L} \end{aligned} \quad (5)$$

where  $z_n$  is a new constant. Now, set  $u = -100$  at time  $t = 0$  as in the hint, and since final solution is a sum of the above solution (4), then we get

$$\begin{aligned} -100 &= \sum z_n \frac{1}{r} \sin \frac{n\pi r}{L} \\ -100 r &= \sum z_n \sin \frac{n\pi r}{L} \end{aligned}$$

Now we need to find  $z_n$ . Taking inner product w.r.t.  $\sin \frac{m\pi r}{L}$ , all terms on the RHS vanish except for when  $n = m$

$$\begin{aligned} -100 \int_{r=0}^{r=L} r \sin \frac{n\pi r}{L} dr &= \int_0^L \left( \sum_{m=0}^{\infty} z_m \sin \left( \frac{m\pi r}{L} \right) \right) \sin \frac{n\pi r}{L} dr \\ -100 \left[ \frac{L^2(-n\pi \cos(n\pi) + \sin(n\pi))}{n^2\pi^2} \right] &= \int_0^L c_n \sin^2 \left( \frac{n\pi r}{L} \right) dr \\ 100 \left[ \frac{L^2 n\pi \cos(n\pi)}{n^2\pi^2} \right] &= z_n \int_0^L \sin^2 \left( \frac{n\pi r}{L} \right) dr \\ 100 \left[ \frac{L^2 \cos(n\pi)}{n\pi} \right] &= z_n \frac{L}{2} \\ 200 \left[ \frac{L \cos(n\pi)}{n\pi} \right] &= z_n \\ 200 \frac{L}{n\pi} \cos(n\pi) &= z_n \\ 200 \frac{L}{n\pi} (-1)^n &= z_n \end{aligned}$$

Substituting into (5) gives

$$\begin{aligned} u(r, t) &= \sum \left[ 200 \frac{L}{n\pi} (-1)^n \right] \frac{1}{r} e^{-\left(\frac{n\pi}{L}\alpha\right)^2 t} \sin \frac{n\pi r}{L} \\ u(r, t) &= \frac{200L}{\pi r} \sum \frac{1}{n} (-1)^n e^{-\left(\frac{n\pi}{L}\alpha\right)^2 t} \sin \frac{n\pi r}{L} \end{aligned}$$

Now adding the 100 which was subtracted at the start, hence the final solution is

$$u(r, t) = 100 + \frac{200L}{\pi r} \sum \frac{1}{n} (-1)^n e^{-\left(\frac{n\pi}{L}\alpha\right)^2 t} \sin \frac{n\pi r}{L}$$

To verify, setting  $r = L$  gives

$$\begin{aligned}u(L, t) &= 100 + \frac{200L}{\pi r} \sum \frac{1}{n} (-1)^n e^{-\left(\frac{n\pi}{L}\alpha\right)^2 t} \sin \frac{n\pi L}{L} \\ &= 100 + 0 \\ &= 100\end{aligned}$$

Which is the correct boundary condition for  $t > 0$ .

Another way to solve the above is to not convert  $j_0$  to sin function, and use the orthogonality based on the spherical Bessel functions to find the coefficients. The same answer will be obtained.

## 4 chapter 13, problem 7.16 Mary Boas, second edition

Separate the wave equation in spherical coordinates and show that the  $\theta, \phi$  solutions are the spherical harmonics  $P_l^m(\cos \theta)e^{\pm im\phi}$  and the  $r$  solutions are spherical Bessel functions  $j_l(kr)$  and  $y_l(kr)$

### Solution

Since we want the wave equation

$$\nabla^2 u = \frac{1}{v^2} \frac{\partial^2 u}{\partial t^2}$$

Using the spherical Laplacian operator, the wave equation is written as

$$\frac{1}{r^2} \frac{\partial}{\partial r} \left( r^2 \frac{\partial u}{\partial r} \right) + \frac{1}{r^2} \frac{1}{\sin \theta} \frac{\partial}{\partial \theta} \left( \sin \theta \frac{\partial u}{\partial \theta} \right) + \frac{1}{r^2 \sin^2 \theta} \frac{\partial^2 u}{\partial \phi^2} = \frac{1}{v^2} \frac{\partial^2 u}{\partial t^2}$$

Let

$$u(r, \theta, \phi, t) = R(r)\Theta(\theta)\Phi(\phi)T(t)$$

Substituting into the wave equation and multiplying by  $\frac{1}{R(r)\Theta(\theta)\Phi(\phi)T(t)}$

$$\frac{1}{R} \frac{1}{r^2} \frac{d}{dr} \left( r^2 \frac{dR}{dr} \right) + \frac{1}{\Theta} \frac{1}{r^2} \frac{1}{\sin \theta} \frac{d}{d\theta} \left( \sin \theta \frac{d\Theta}{d\theta} \right) + \frac{1}{r^2 \sin^2 \theta} \frac{1}{\Phi} \frac{d^2 \Phi}{d\phi^2} = \frac{1}{v^2} \frac{1}{T} \frac{d^2 T}{dt^2} \quad (1)$$

Applying variable separation. Multiplying (1) by  $r^2 \sin^2 \theta$  gives

$$\frac{\sin \theta}{R} \frac{d}{dr} \left( r^2 \frac{dR}{dr} \right) + \frac{1}{\Theta} \sin \theta \frac{d}{d\theta} \left( \sin \theta \frac{d\Theta}{d\theta} \right) + \overbrace{\frac{1}{\Phi} \frac{d^2 \Phi}{d\phi^2}} = \frac{r^2 \sin^2 \theta}{v^2} \frac{1}{T} \frac{d^2 T}{dt^2}$$

The last term on the LHS is a constant. Therefore  $\frac{1}{\Phi} \frac{d^2 \Phi}{d\phi^2}$  is a constant, say  $-m^2$ , hence

$$\Phi = \begin{cases} \sin m\phi \\ \cos m\phi \end{cases} \quad (2)$$

And (1) becomes



$$\frac{1}{R} \frac{1}{r^2} \frac{d}{dr} \left( r^2 \frac{dR}{dr} \right) + \frac{1}{\Theta} \frac{1}{r^2} \frac{1}{\sin \theta} \frac{d}{d\theta} \left( \sin \theta \frac{d\Theta}{d\theta} \right) + \frac{-m^2}{r^2 \sin^2 \theta} = \overbrace{\frac{1}{v^2} \frac{1}{T} \frac{d^2 T}{dt^2}} \quad (1A)$$

Now separating the Time solution. The RHS does not depend on  $r, \theta, \phi$ , and is equal to something that does. Hence it is a constant. Say  $-k^2$ , therefore

$$\frac{1}{v^2} \frac{1}{T} \frac{d^2 T}{dt^2} = -k^2$$

The above do not need to be solved as not required by problem, however its solution is

$$\begin{aligned} \frac{d^2 T}{dt^2} &= -v^2 k^2 T \\ \frac{d^2 T}{dt^2} + v^2 k^2 T &= 0 \\ T(t) &= A e^{ikvt} + B e^{-ikvt} \end{aligned}$$

Now (1A) becomes

$$\begin{aligned} \frac{1}{R} \frac{1}{r^2} \frac{d}{dr} \left( r^2 \frac{dR}{dr} \right) + \frac{1}{\Theta} \frac{1}{r^2} \frac{1}{\sin \theta} \frac{d}{d\theta} \left( \sin \theta \frac{d\Theta}{d\theta} \right) + \frac{-m^2}{r^2 \sin^2 \theta} &= -k^2 \\ \frac{1}{R} \frac{1}{r^2} \frac{d}{dr} \left( r^2 \frac{dR}{dr} \right) + \frac{1}{\Theta} \frac{1}{r^2} \frac{1}{\sin \theta} \frac{d}{d\theta} \left( \sin \theta \frac{d\Theta}{d\theta} \right) + \frac{-m^2}{r^2 \sin^2 \theta} + k^2 &= 0 \end{aligned} \quad (1B)$$

Separating the  $\theta$  solution. multiplying (1B) by  $r^2$  gives

$$\frac{1}{R} \frac{d}{dr} \left( r^2 \frac{dR}{dr} \right) + \overbrace{\frac{1}{\Theta} \frac{1}{\sin \theta} \frac{d}{d\theta} \left( \sin \theta \frac{d\Theta}{d\theta} \right) + \frac{-m^2}{\sin^2 \theta}} + r^2 k^2 = 0 \quad (1C)$$

The bracketed term is a constant, hence

$$\begin{aligned} \frac{1}{\Theta} \frac{1}{\sin \theta} \frac{d}{d\theta} \left( \sin \theta \frac{d\Theta}{d\theta} \right) - \frac{m^2}{\sin^2 \theta} &= -\zeta \\ \frac{1}{\Theta} \frac{1}{\sin \theta} \frac{d}{d\theta} \left( \sin \theta \frac{d\Theta}{d\theta} \right) - \frac{m^2}{\sin^2 \theta} + \zeta &= 0 \\ \frac{1}{\sin \theta} \frac{d}{d\theta} \left( \sin \theta \frac{d\Theta}{d\theta} \right) - \frac{m^2}{\sin^2 \theta} \Theta + \zeta \Theta &= 0 \end{aligned}$$

As per page 568 in text book, the above is the equation for the associated Legendre functions if  $\zeta = l(l + 1)$  The solution is given by

$$\Theta = P_l^m(\cos \theta) \quad (4)$$

Hence the  $\theta, \phi$  solutions are given by equations (3) and (4)

$$\begin{aligned} &= P_l^m(\cos \theta) \begin{cases} \sin m\phi \\ \cos m\phi \end{cases} \\ &= P_l^m(\cos \theta) e^{\pm im\phi} \end{aligned}$$

Which is what we are required to show.

(1C) now becomes

$$\frac{1}{R} \frac{d}{dr} \left( r^2 \frac{dR}{dr} \right) - \zeta + r^2 k^2 = 0$$

For the radial solution, from equation above for radial equation:

$$\begin{aligned} &\frac{d}{dr} \left( r^2 \frac{dR}{dr} \right) + R r^2 k^2 - R \zeta = 0 \\ r^2 \frac{d^2 R}{dr^2} + 2r \frac{dR}{dr} + R r^2 k^2 - R \zeta &= 0 \end{aligned}$$

Dividing by  $r^2$

$$\begin{aligned} &\frac{d^2 R}{dr^2} + \frac{2}{r} \frac{dR}{dr} + R k^2 - R \frac{\zeta}{r^2} = 0 \\ \frac{d^2 R}{dr^2} + \frac{2}{r} \frac{dR}{dr} + \left( k^2 - \frac{\zeta}{r^2} \right) R &= 0 \end{aligned} \quad (5)$$

The above equation is of the form 16.1 on page 516:

$$y'' + \frac{1-2a}{x} y' + \left[ (bcx^{c-1})^2 + \frac{a^2 - p^2 c^2}{x^2} \right] y = 0 \quad (16.1)$$

Whose solution is given by 16.2:  $y = x^a Z_p(bx^c)$ . Hence by comparison between 16.1 and (5) (and writing the independent variable  $x$  as  $r$ )

$$\begin{aligned}\frac{1-2a}{r} &= \frac{2}{r} \\ (bcr^{c-1})^2 &= k^2 \\ \frac{a^2 - p^2 c^2}{r^2} &= -\frac{\zeta}{r^2}\end{aligned}$$

Therefore,  $c = 1$ , and  $b = k$ ,  $1 - 2a = 2 \rightarrow \boxed{a = \frac{1}{2}}$ . And  $a^2 - p^2 c^2 = -\zeta \Rightarrow \frac{1}{4} - p^2 = -\zeta \Rightarrow \boxed{p = \sqrt{\frac{1}{4} + \zeta}}$

So solution to radial component is

$$R = r^{\frac{1}{2}} Z_{\sqrt{\frac{1}{4} + \zeta}}(kr)$$

Where  $Z$  stands for  $J$  or  $N$ . Let  $\sqrt{\frac{1}{4} + \zeta} = n$  some constant (since  $\zeta$  is a constant). The solution is

$$R = \sqrt{r} J_n(kr)$$

Or

$$R = \sqrt{r} Y_n(kr)$$

From equation (17.4) we see that the  $J$  and  $Y$  Bessel function are related to the spherical Bessel function  $j$  and  $y$ , this means the radial solution  $R(r)$  can be expressed in terms of the spherical Bessel functions.

## 5 chapter 13, problem 7.17 Mary Boas, second edition

Separate the Schrodinger equation  $\nabla^2\psi + (\epsilon - bV)\psi = 0$  in spherical coordinates

Solution

$V$  is function of  $r$  only, so we have

$$\nabla^2\psi(r, \theta, \phi) + (\epsilon - bV(r))\psi(r, \theta, \phi) = 0$$

Using the spherical Laplacian operator, the above equation is written as

$$\frac{1}{r^2} \frac{\partial}{\partial r} \left( r^2 \frac{\partial u}{\partial r} \right) + \frac{1}{r^2} \frac{1}{\sin \theta} \frac{\partial}{\partial \theta} \left( \sin \theta \frac{\partial u}{\partial \theta} \right) + \frac{1}{r^2 \sin^2 \theta} \frac{\partial^2 u}{\partial \phi^2} + (\epsilon - bV(r))\psi(r, \theta, \phi) = 0$$

Let

$$\psi(r, \theta, \phi) = R(r)\Theta(\theta)\Phi(\phi)$$

Substituting into the above equation and multiplying by  $\frac{r^2}{R(r)\Theta(\theta)\Phi(\phi)}$  gives

$$\overbrace{\frac{1}{R} \frac{d}{dr} \left( r^2 \frac{dR}{dr} \right) + (\epsilon - bV(r)) r^2} + \frac{1}{\Theta \sin \theta} \frac{d}{d\theta} \left( \sin \theta \frac{d\Theta}{d\theta} \right) + \frac{1}{\Phi \sin^2 \theta} \frac{d^2\Phi}{d\phi^2} = 0 \quad (1)$$

The bracketed part above depends only on  $r$  and is equal to a function that does not depend on  $r$ , hence it must be constant. Calling it  $k$ , (1) becomes

$$k + \frac{1}{\Theta \sin \theta} \frac{d}{d\theta} \left( \sin \theta \frac{d\Theta}{d\theta} \right) + \frac{1}{\Phi \sin^2 \theta} \frac{d^2\Phi}{d\phi^2} = 0 \quad (2)$$

Multiplying by  $\sin^2 \theta$  gives

$$k \sin^2 \theta + \frac{1}{\Theta} \sin \theta \frac{d}{d\theta} \left( \sin \theta \frac{d\Theta}{d\theta} \right) + \overbrace{\frac{1}{\Phi} \frac{d^2\Phi}{d\phi^2}} = 0$$

The bracketed part can be separated out  $\frac{1}{\Phi} \frac{d^2\Phi}{d\phi^2} = -m^2$ . Hence the solutions are

$$\Phi = \begin{cases} \sin m\phi \\ \cos m\phi \end{cases}$$

So now equation (2) becomes

$$k + \frac{1}{\Theta} \frac{1}{\sin \theta} \frac{d}{d\theta} \left( \sin \theta \frac{d\Theta}{d\theta} \right) - \frac{m^2}{\sin^2 \theta} = 0$$

$$\frac{1}{\sin \theta} \frac{d}{d\theta} \left( \sin \theta \frac{d\Theta}{d\theta} \right) - \frac{m^2}{\sin^2 \theta} \Theta + k\Theta = 0$$

As per page 568 in text book, this has a solution of  $\Theta = P_l^m(\cos \theta)$ . Hence the  $\theta, \phi$  solution is

$$P_l^m(\cos \theta)\Phi = \begin{cases} \sin m\phi \\ \cos m\phi \end{cases}$$

We notice that the angular solution are identical to the Laplace equation and expressed in terms of spherical harmonics.

## 6 chapter 13, problem 8.1, Mary Boas, second edition.

---

Show that gravitational potential  $V(x, y, z) = -\frac{Gm}{r}$  satisfies Laplace equation

Solution

$$V(x, y, z) = -\frac{Gm}{r} = -\frac{Gm}{\sqrt{x^2 + y^2 + z^2}} = -Gm(x^2 + y^2 + z^2)^{-\frac{1}{2}}$$

Hence

$$\begin{aligned}\frac{\partial V}{\partial x} &= -Gm\left(-\frac{1}{2}\right)(x^2 + y^2 + z^2)^{-\frac{3}{2}}(2x) \\ &= Gm(x^2 + y^2 + z^2)^{-\frac{3}{2}}(x)\end{aligned}$$

$$\begin{aligned}\frac{\partial^2 V}{\partial x^2} &= Gm\left[(x^2 + y^2 + z^2)^{-\frac{3}{2}} \times 1 + x\left(-\frac{3}{2}(x^2 + y^2 + z^2)^{-\frac{5}{2}}(2x)\right)\right] \\ &= Gm\left[(x^2 + y^2 + z^2)^{-\frac{3}{2}} - 3x^2(x^2 + y^2 + z^2)^{-\frac{5}{2}}\right]\end{aligned}\quad (1)$$

Similarly, we find

$$\frac{\partial^2 V}{\partial y^2} = Gm\left[(x^2 + y^2 + z^2)^{-\frac{3}{2}} - 3y^2(x^2 + y^2 + z^2)^{-\frac{5}{2}}\right]\quad (2)$$

And

$$\frac{\partial^2 V}{\partial z^2} = Gm\left[(x^2 + y^2 + z^2)^{-\frac{3}{2}} - 3z^2(x^2 + y^2 + z^2)^{-\frac{5}{2}}\right]\quad (3)$$

Add (1),(2),(3) we get

$$\begin{aligned}\frac{\partial^2 V}{\partial x^2} + \frac{\partial^2 V}{\partial y^2} + \frac{\partial^2 V}{\partial z^2} &= 3Gm(x^2 + y^2 + z^2)^{-\frac{3}{2}} - 3Gm(x^2 + y^2 + z^2)^{-\frac{5}{2}}(x^2 + y^2 + z^2) \\ \nabla^2 V(x, y, z) &= 3Gm(x^2 + y^2 + z^2)^{-\frac{3}{2}} - 3Gm(x^2 + y^2 + z^2)^{-\frac{3}{2}} \\ \nabla^2 V(x, y, z) &= 0\end{aligned}$$

Hence  $V(x, y, z)$  satisfies Laplace equation.

## 7 chapter 13, problem 8.2 Mary Boas, second edition

---

Using formulas in chapter 12 section 5, sum the series in 8.20 to get 8.21

Solution

Series in 8.20 is

$$q \sum_l \frac{R^{2l+1} P_l(\cos \theta)}{r^{l+1} a^{l+1}} \quad (8.20)$$

We want to show that the above can simplify to 8.21, which is

$$\frac{\frac{R}{a}q}{\sqrt{r^2 + \left(\frac{R^2}{a}\right)^2 - 2r\left(\frac{R^2}{a}\right)\cos \theta}} \quad (8.21)$$

Let  $\frac{R^2}{ar} = h$  then  $\frac{R^2}{a} = rh$ , and  $\frac{R}{a} = \frac{rh}{R}$  and  $\cos \theta = x$

8.21 becomes

$$\begin{aligned} \frac{\frac{R}{a}q}{\sqrt{r^2 + \left(\frac{R^2}{a}\right)^2 - 2r\left(\frac{R^2}{a}\right)\cos \theta}} &= \frac{\frac{rh}{R}q}{\sqrt{r^2 + (rh)^2 - 2r(rh)x}} \\ &= \frac{\frac{rh}{R}q}{\sqrt{r^2 + r^2h^2 - 2r^2hx}} \\ &= \frac{\frac{rh}{R}q}{r\sqrt{1 + h^2 - 2hx}} \end{aligned}$$

From 5.1 on page 490, we see that  $\Phi(x, h) = (1 - 2hx + h^2)^{-\frac{1}{2}}$

So the above equation becomes

$$\frac{\frac{R}{a}q}{\sqrt{r^2 + \left(\frac{R^2}{a}\right)^2 - 2r\left(\frac{R^2}{a}\right)\cos \theta}} = \frac{\frac{rh}{R}q}{r} \Phi(x, h)$$



Using 5.2, we expand the  $\Phi(x, h)$  as  $\sum_l h^l P_l(x)$

Hence

$$\begin{aligned} \frac{\frac{R}{a}q}{\sqrt{r^2 + \left(\frac{R^2}{a}\right)^2 - 2r\left(\frac{R^2}{a}\right)\cos\theta}} &= \frac{\frac{rh}{R}q}{r}\Phi(x, h) \\ &= \frac{hq}{R} \sum_l h^l P_l(x) \end{aligned}$$

Substitute back  $\cos\theta = x$ , and  $\frac{R^2}{ar} = h$  in above we get

$$\begin{aligned} \frac{\frac{R}{a}q}{\sqrt{r^2 + \left(\frac{R^2}{a}\right)^2 - 2r\left(\frac{R^2}{a}\right)\cos\theta}} &= \frac{\left(\frac{R^2}{ar}\right)q}{R} \sum_l \left(\frac{R^2}{ar}\right)^l P_l(x) \\ &= \frac{Rq}{ar} \sum_l \frac{R^{2l}}{a^l r^l} P_l(x) \\ &= q \sum_l \frac{R^{2l+1}}{a^{l+1} r^{l+1}} P_l(x) \end{aligned}$$

Which is 8.20. Hence this shows that 8.20 can be simplified to 8.21

## 8 chapter 13, problem 8.3, Mary Boas, second edition.

---

Do the problem in example 1 for the case of a charge  $q$  inside a grounded sphere to obtain the potential  $V$  inside the sphere.

### Solution

Starting the example from equation 8.15, which is the basic solution of Laplace in spherical coordinates

$$\left\{ \begin{array}{l} r^l \\ r^{-l-1} \end{array} P_l^m(\cos \theta) \right\} \left\{ \begin{array}{l} \sin m\phi \\ \cos m\phi \end{array} \right.$$

Since we want a solution inside the sphere, we select the  $r^l$  solution for  $r$  since we do not want the solution to go to  $\infty$  as  $r \rightarrow 0$

Also, since the solution is independent of the  $\phi$ , we do not want solution with  $\phi$ , hence set  $m = 0$ , hence the basic solution is

$$V = r^l P_l(\cos \theta)$$

Since the general solution is a sum of these solutions, we get

$$V = \sum_l c_l r^l P_l(\cos \theta)$$

Now add a solution to Laplace solution so that the potential is zero at the surface, this is  $V_q$  as shown in the example on page 575:

$$V_q = \frac{q}{\sqrt{r^2 - 2ar \cos \theta + a^2}}$$

hence the general solution now becomes

$$\begin{aligned} V &= V_q + \sum_l c_l r^l P_l(\cos \theta) \\ &= \frac{q}{\sqrt{r^2 - 2ar \cos \theta + a^2}} + \sum_l c_l r^l P_l(\cos \theta) \end{aligned} \quad (1)$$

Now, boundary condition is  $V = 0$  at  $r = R$  so from (1)

$$\begin{aligned}
0 &= V_q + \sum_l c_l R^l P_l(\cos \theta) \\
&= \frac{q}{\sqrt{R^2 - 2aR \cos \theta + a^2}} + \sum_l c_l R^l P_l(\cos \theta)
\end{aligned} \tag{2}$$

As per example,  $\frac{q}{\sqrt{R^2 - 2aR \cos \theta + a^2}} = q \sum_l \frac{R^l P_l(\cos \theta)}{a^{l+1}}$

Hence (2) becomes

$$\begin{aligned}
0 &= q \sum_l \frac{R^l P_l(\cos \theta)}{a^{l+1}} + \sum_l c_l R^l P_l(\cos \theta) \\
-q \sum_l \frac{R^l P_l(\cos \theta)}{a^{l+1}} &= \sum_l c_l R^l P_l(\cos \theta)
\end{aligned}$$

Compare coefficients, we see that

$$c_l R^l = -q \frac{R^l}{a^{l+1}} \rightarrow c_l = -q \frac{1}{a^{l+1}}$$

Hence (1) becomes

$$V = \frac{q}{\sqrt{r^2 - 2ar \cos \theta + a^2}} - q \sum_l \frac{r^l}{a^{l+1}} P_l(\cos \theta)$$

Now we sum the series solution. Need to convert the series into form shown in 5.2:  $\Phi(x, h) = \sum_l h^l P_l(x)$  then we can replace the sum with  $(1 - 2xh + h^2)^{-\frac{1}{2}}$

So we need to have  $\frac{1}{a} \left(\frac{r}{a}\right)^l = h^l$  hence

$$(1 - 2xh + h^2)^{-\frac{1}{2}} = \left(1 - 2x\left(\frac{r}{a^2}\right) + \left(\frac{r^2}{a^3}\right)\right)^{-\frac{1}{2}}$$

Then the series solution sums to be

$$V = \frac{q}{\sqrt{r^2 - 2ar \cos \theta + a^2}} - \frac{q}{\sqrt{\left(1 - 2 \cos \theta \left(\frac{r}{a^2}\right) + \left(\frac{r^2}{a^3}\right)\right)}}$$

The second term above is the potential of a charge  $-q$  at a point  $\left(0, 0, \frac{1}{a}\right)$ , thus we could replace the grounded sphere by this charge and get the same potential for  $r > R$  this is called the method of images, per book, page 576 discussion.